

White LED Driver with Synchronous Boost Converter and PWM Brightness Control for up to 3 LEDs in Series



BD6071HFN

●General Description

BD6071HFN is boost DC/DC converter possible to boost output voltage up to 14V (Max.) and drive the white LEDs at constant. It is possible that turning on white LED steadily by a series connection which has no current variation, and by a fast transient response with current mode. And, BD6071HFN is white LED driver IC with synchronous rectification. With synchronous rectification (no external schottky diode required) and small package, they can save mount space.

●Features

- Boost DC/DC converter
- Adjustment of brightness by external PWM pulse
- Possible to driving 3 LEDs
- Soft start function
- Synchronous rectification Boost DC/DC converter
- No external schottky diode required
- Output Open • Short protect

●Key Specifications

- Operating power supply voltage range: 2.7V to 5.5V
- Switching frequency: 1MHz(Typ.)
- Quiescent Current: 0.1μA (Typ.)
- Operating temperature range: -30°C to +85°C

●Package W(Typ.) x D(Typ.) x H(Max.)



HSON8
2.90mm x 3.00mm x 0.60mm

●Applications

This driver is applicable for various fields such as mobile phones, portable game machines, Inter-phone camera, audio player, portable DVD player, back light for printer display etc... and support light of the camera for the mobile phone, simple flash. And, these can use power supply for OEL.

●Typical Application Circuit

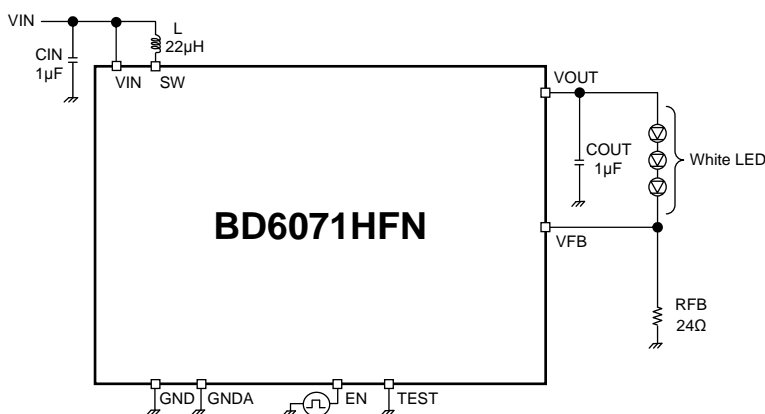

●Pin Configuration [Top View]

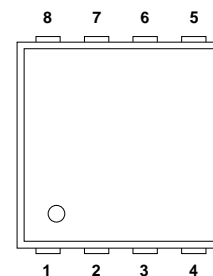

Figure 1. Pin configuration HSON8 (Top view)

● Absolute Maximum Ratings (Ta=25°C)

Parameter	Symbol	Ratings	Unit	Conditions
Terminal voltage 1	VMAX1	7 *1	V	Applicable to VIN,EN,VFB, TEST pins
Terminal voltage 2	VMAX2	20 *1	V	Applicable to SW,VOUT pins
Power dissipation	Pd	630 *2	mW	70mmx70mmx1.6mm at glass epoxy board mounting
Operating temperature range	Topr	-30 ~ +85	°C	
Storage temperature range	Tstg	-55 ~ +150	°C	

*1 These values are based on GND and GNDA pins.

*2 When it's used by more than Ta=25°C, it's reduced by 5.04mW/°C.

● Recommended Operating Ratings (Ta=-30°C to +85°C)

Parameter	Symbol	Ratings			Unit	Conditions
		Min.	Typ.	Max.		
Operating supply voltage	VIN	2.7	3.6	5.5	V	VIN pin

● Electrical Characteristics (Unless otherwise specified Ta = +25°C, VIN = 3.6V)

Parameter	Symbol	Limits			Unit	Conditions
		Min.	Typ.	Max.		
<EN Terminal>						
EN threshold voltage (Low)	VthL	-	-	0.4	V	
EN threshold voltage (High)	VthH	1.4	-	-	V	
EN terminal input current	Iin	-	18.3	30.0	μA	EN=5.5V
EN terminal output current	Iout	-2.0	-0.1	-	μA	EN=0V
<Switching regulator>						
Quiescent Current	Iq	-	0.1	2.0	μA	EN=0V
Current Consumption	Idd	-	1.1	1.5	mA	EN=2.6V,VFB=1.0V,VIN=3.6V
Feedback voltage	VFB	0.47	0.50	0.53	V	
Inductor current limit	Icoil	200	265	330	mA	VIN =3.6V *1
SW saturation voltage	Vsat	-	0.14	0.28	V	Isw=200mA, VOUT=13V
SW on resistance P	Ronp	-	2.1	3.2	Ω	Ipch=200mA, VOUT =13V
Switching frequency	fSW	0.8	1.0	1.2	MHz	
Duty cycle limit	Duty	82.7	85.0	-	%	VFB=0V
Output voltage range	Vo	-	-	14.0	V	
Over voltage limit	Ovl	14.0	14.5	15.0	V	VFB=0V
Start up time	Ts	-	0.5	1.0	ms	

*1 This parameter is tested with dc measurement.

● Pin Descriptions

PIN Name	In/Out	Pin number	Function
GNDA	-	1	Analog GND
EN	In	2	Enable control(pull down is integrated on resistance)
TEST	In	3	TEST input (pull down is integrated on resistance)
VIN	In	8	Power supply input
VFB	In	4	Feedback input voltage
VOUT	Out	7	Output
SW	In	6	Switching terminal
GND	-	5	Power GND
Thermal PAD	-	-	Heat radiation PAD of back side Connect to GNDA

● Block Diagram

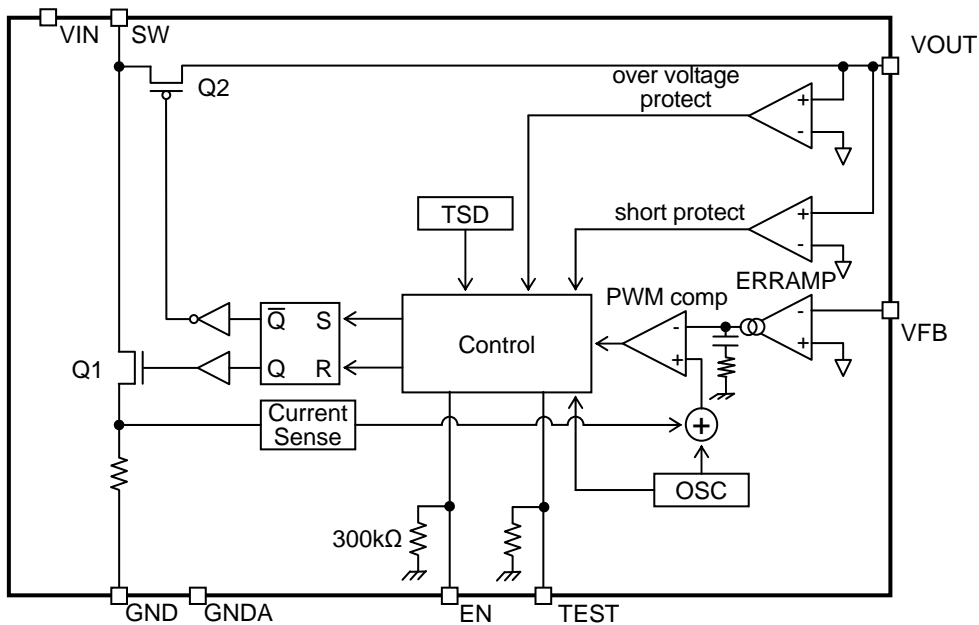

● Typical Performance Curves

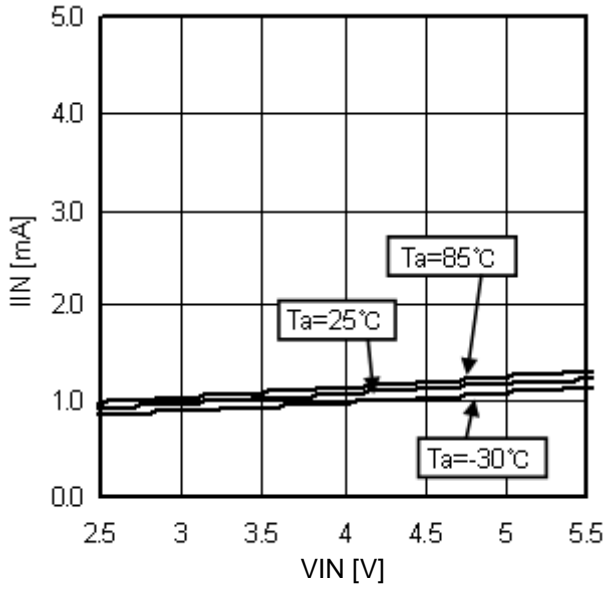

Figure 2. Current Consumption vs. power source voltage

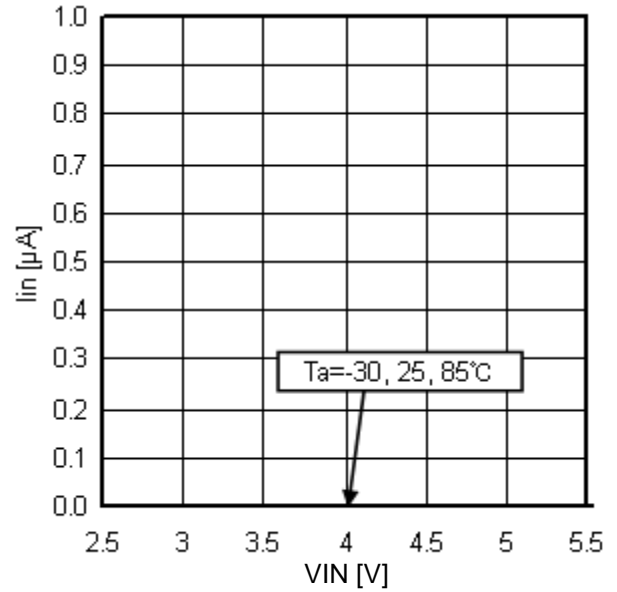

Figure 3. Quiescent current vs. power source voltage

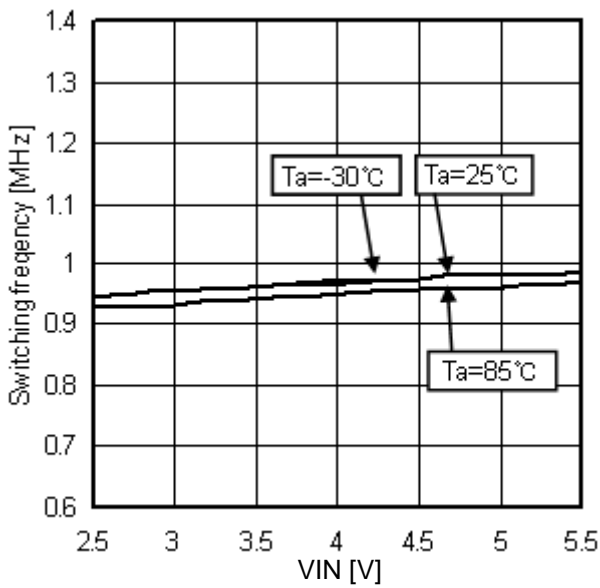

Figure 4. Oscillation frequency vs. power source voltage

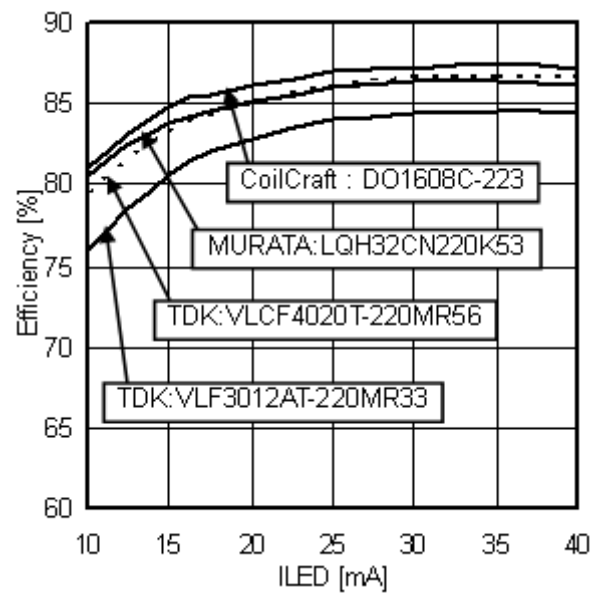

Figure 5. Efficiency vs. LED current in each coil < 2LED > (VOUT=7.5V, VIN=3.6V, Ta=25°C)

● Typical Performance Curves - continued

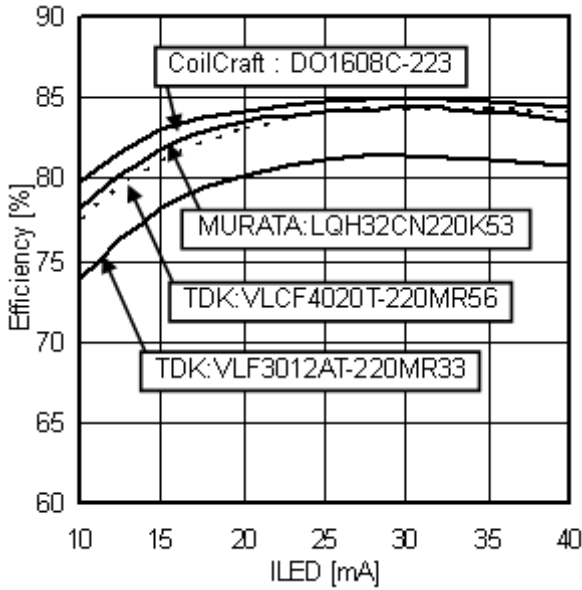

Figure 6. Efficiency vs. LED current in each coil < 3LED > (VOUT=10.5V, VIN=3.6V, Ta=25°C)

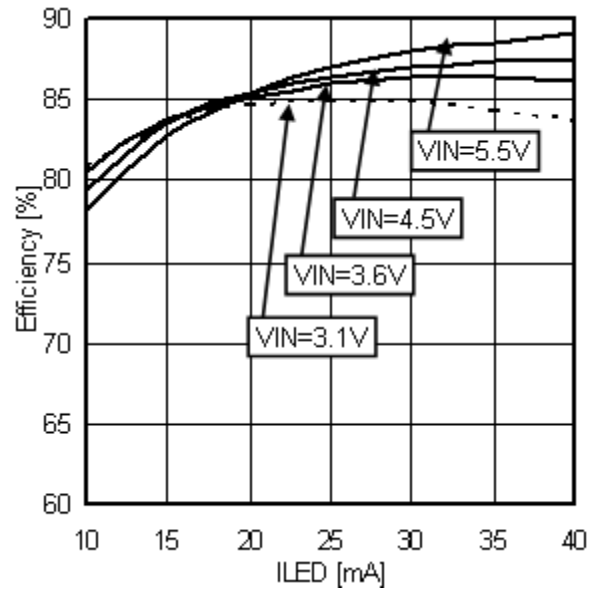

Figure 7. Efficiency vs. LED current < 2LED > (VOUT=7.5V, Ta=25°C)

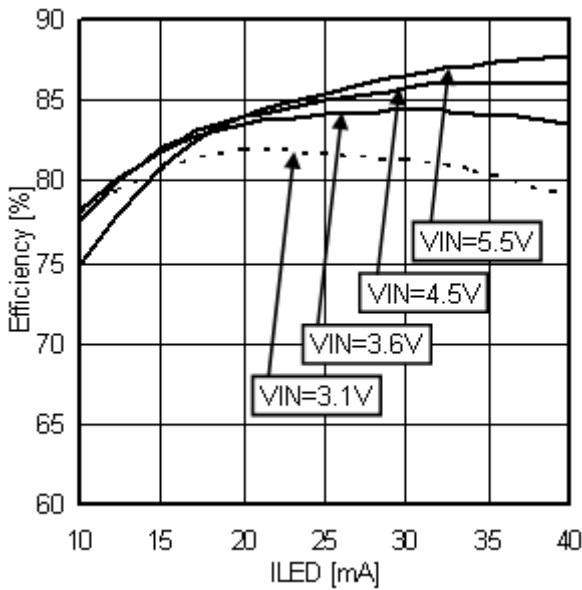

Figure 8. Efficiency vs. LED current < 3LED > (VOUT=10.5V, Ta=25°C)

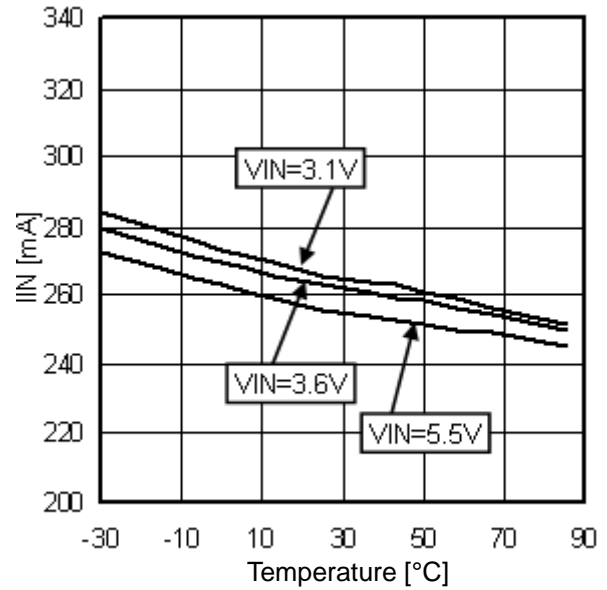

Figure 9. Inductor current limits vs. Temperature

● Typical Performance Curves - continued

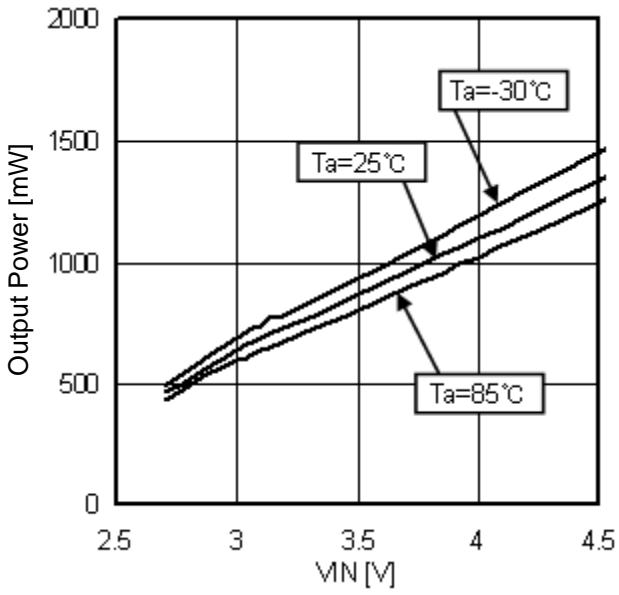

Figure 10. Output power vs. power source voltage

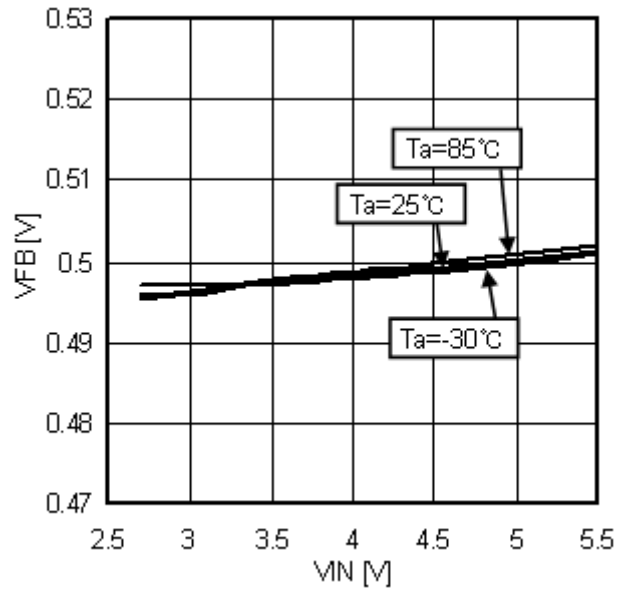

Figure 11. Feedback voltage vs. Power source voltage

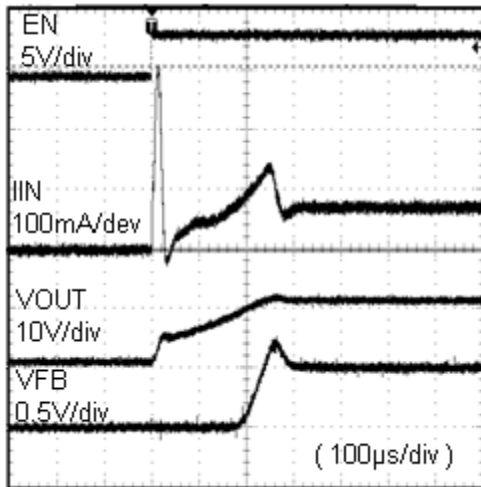

Figure 12. Soft Start
(VIN = 3.6V, Ta = 25°C, 3LED, 20mA Load)

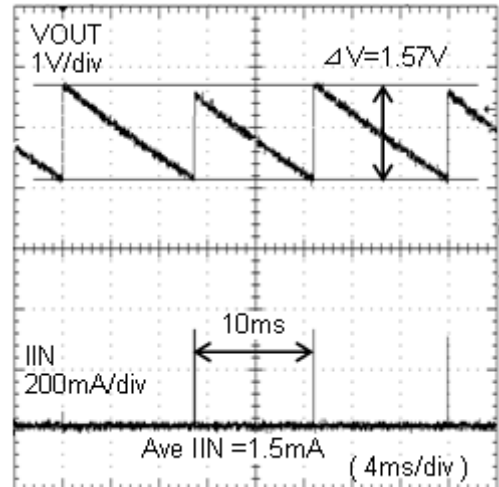

Figure 13. LED Open output voltage

● Typical Performance Curves - continued

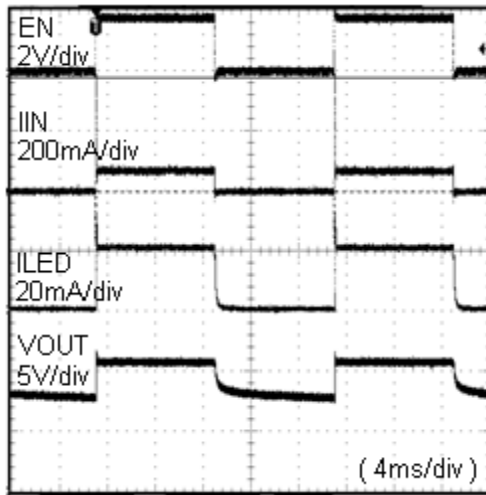

Figure 14. LED luminance adjustment
($V_{IN} = 3.6V$, $T_a = 25^{\circ}C$, 3LED, 20mA Load)

● Operation

BD6071HFN is a fixed frequency PWM current mode DC/DC converter, and adopts synchronous rectification architecture (Refer to the Block Diagram of p.3). As for the inputs of the PWM comparator as the feature of the PWM current mode, one is overlapped with error components from the error amplifier, and the other is overlapped with a current sense signal that controls the inductor current into Slope waveform for sub harmonic oscillation prevention. This output controls Q1 and Q2 via the RS latch.

Timing of Q1 and Q2 is precisely adjusted so that they will not turn ON at the same time, thus putting them into non-overlapped relation.

In the period where Q1 is ON, energy is accumulated in the external inductor, and in the period where Q1 is OFF, energy is transferred to the capacitor of VOUT via Q2.

Further, BD6071HFN has many safety functions, and their detection signals stop switching operation at once.

● Description of Functions

1) Soft starts and off status

BD6071HFN has soft start function and off status function.

The soft start function and the off status function prevent large current from flowing to the IC via coil.

Occurrence of rush current at turning on is prevented by the soft start function, and occurrence of invalid current at turning off is prevented by the off status function.

2) Isolation control

BD6071HFN has isolation control to prevent LED wrong lighting at power off.

The cause of the LED wrong lighting is leak current from VIN to the white LED.

Therefore, when BD6071HFN gets in power off (EN = L), the isolation control cuts the DC path between SW and VOUT, thereby the leak current from VIN to LED is prevented.

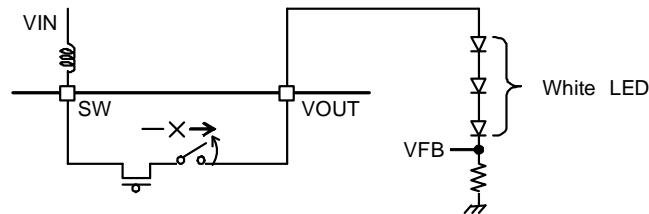

Figure 15. Isolation control

3) Short-circuit protection and over voltage protection

BD6071HFN has short-circuit protection and over voltage protection. These detect the voltage of VOUT, and at error, they stop the output Tr. Details are as shown below.

• Short-circuit protection

In the case of short-circuit of the DC/DC output (VOUT) to GND, the coil or the IC may be destructed.

Therefore, at such an error as VOUT becoming 0.7V or below, the Under Detector shown in the figure works, and turns off the output Tr, and prevents the coil and the IC from being destructed.

And the IC changes from its action condition into its non-action condition, and current does not flow to the coil (0mA).

• Over voltage protection

At such an error as the IC and the LED being cut off, over voltage causes the SW terminal and the VOUT terminal exceed the absolute maximum ratings, and may destruct the IC. Therefore, when VOUT becomes 14.5V or higher, the over voltage limit works, and turns off the output Tr, and prevents the SW terminal and the VOUT terminal from exceeding the absolute maximum ratings.

At this moment, the IC changes from its action condition into its non action condition, and the output voltage goes down slowly. And, when the output voltage becomes the hysteresis of the over voltage limit or below, the output voltage goes on up to 14.5V once again.

This protection action is shown in Figure 16.

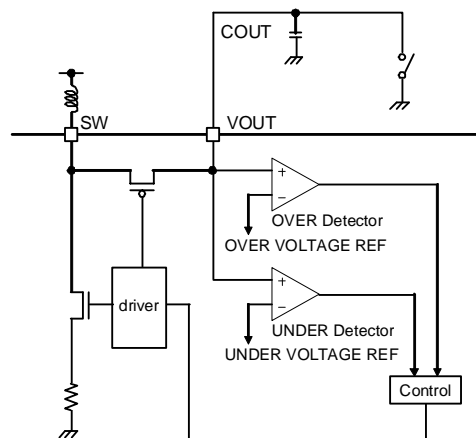

Figure 16. Block diagram of short-circuit protection and over voltage

4) Thermal shut down

BD6071HFN has thermal shut down function.

The thermal shut down works at 175°C or higher, and while holding the setting of EN control from the outside, the IC changes from its action condition into its non action condition. And at 175°C or below, the IC gets back to its normal action.

●Start Control and Brightness Control

BD6071HFN can control the start conditions by its EN terminal, and power off at 0.4V or below, and power on at 1.4V or higher. And by changing the duty of power on and off by PWM control, the LED brightness can be adjusted.

Two techniques are available for the brightness adjustment. One is discrete time (PWM) adjustment, and the other is continuous time adjustment.

1) PWM brightness adjustment is made by giving PWM signal to EN as shown in Figure 17.

The BD6071HFN power on/off is according to the PWM signal. By this method, LED current is controlled from 0 to the maximum current. The average LED current increases in proportion with the duty cycle of PWM signal. While in PWM off-cycle mode, the IC and LED both consume no currents, thus providing a high-efficiency operation. And please don't use duty less than 5% or more than 95% of current setting for the brightness adjustment because of the influence of turning on and off operating is large. The recommended PWM frequency is 100Hz ~ 300Hz.

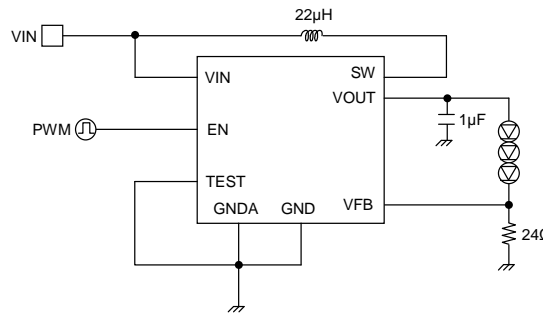

Figure 17. The brightness adjustment example of EN terminal by PWM (f_{PWM} = 100Hz ~ 300Hz)

2-1) The continuous time the brightness adjustment is made by giving DC control voltage to VFB pin of BD6071HFN via a series resistor as shown in Figure 18. LED luminance (current) changed by giving DC voltage to VFB directly. DC voltage is given from filtered one of DAC signal, or PWM signal shown in Figure 20. The advantage of this approach is that the PWM signal to be used to control the LED brightness can be set to a high frequency (1kHz or higher). And please don't use duty less than 5% or more than 95% of current setting for the brightness adjustment.

LED current (I_{LED}) is approximated by the following equation.

$$I_{LED} = \{[(V_{FB}-DAC) / R1] \times R2 + V_{FB}\} / R_{FB}$$

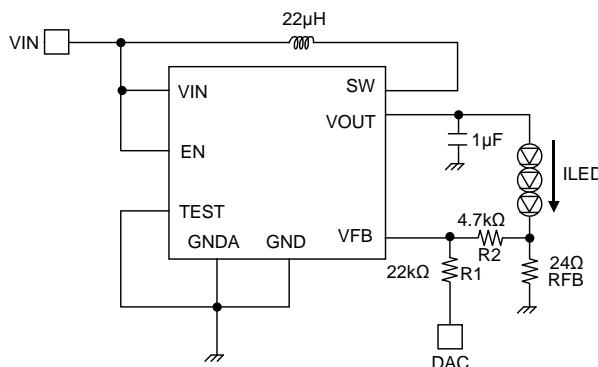

Figure 18. The brightness adjustment example by DAC

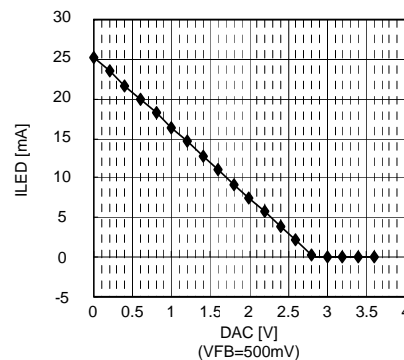

Figure 19. DAC adjustment

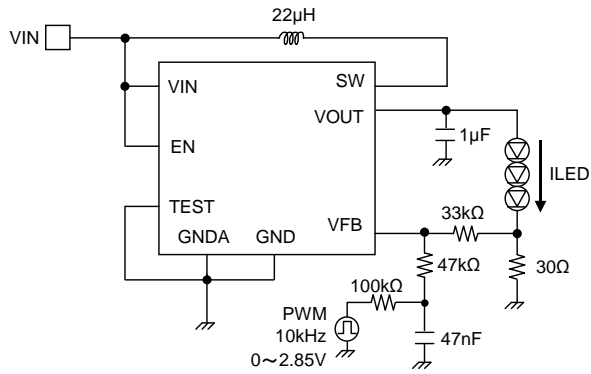

Figure 20. The brightness adjustment example of VFB terminal by PWM ($f_{PWM}=10kHz$)

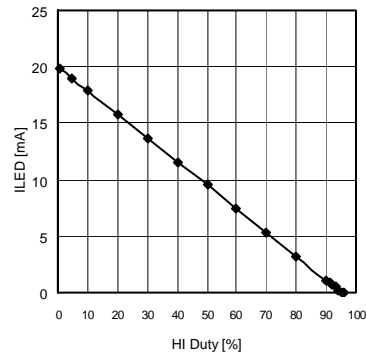

Figure 21. VFB PWM Control

2-2) The brightness adjustment of below is done in adjusting of R2 ON time by R1 and Duty cycle of PWM. The minimum value of the LED current is decided by $V_{FB}/R1$ at the PWM 0%, the maximum value of the LED current is decided by $V_{FB}/R1+V_{FB}/R2$ at the PWM 100%. I_{LED} is given as shown below.

$$I_{LED} = V_{FB} / R1 + V_{FB} / R2 \times HI \text{ Duty}$$

Standard PWM frequency is 100Hz~1kHz. And please don't use duty less than 5% or more than 95% of current setting for the brightness adjustment.

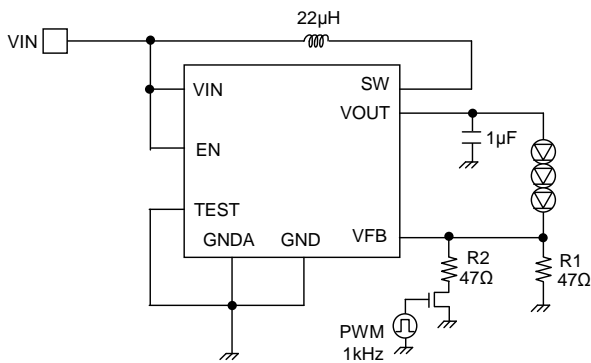

Figure 22. The brightness adjustment example of VFB terminal by PWM ($f_{PWM}=100Hz \sim 1kHz$)

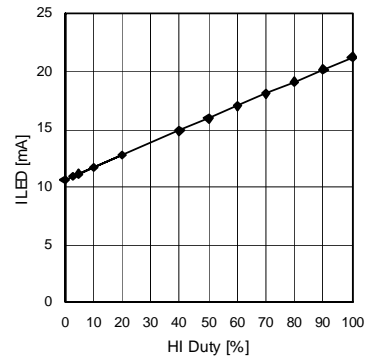

Figure 23. VFB PWM Control

●Setting Range of LED Current

LED current is determined by the voltage of VFB and the resistor connected to VFB terminal.

I_{LED} is given as shown below.

$$I_{LED} = V_{FB} / R_{FB}$$

The current in the standard application is as shown below.

$$V_{FB} = 0.5V, R_{FB} = 24\Omega$$

$$I_{LED} = 20.8mA$$

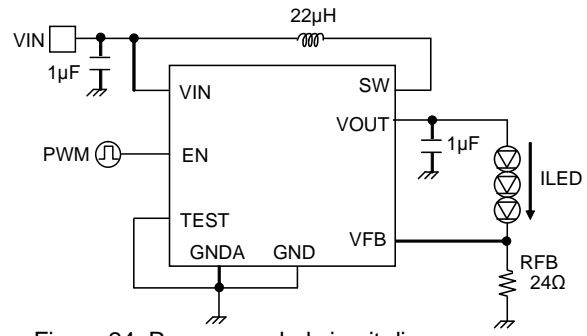

Figure 24. Recommended circuit diagram

The shaded portion in the figure below is the setting range of LED current to become the standard. In case of using 2LED, LED current might increase due to over boosting when V_{OUT} is less than 5.5V. Therefore some ICs may not be used at desired currents. Consequently, for the proper setting of LED current, thoroughly check it for the suitability under use conditions including applicable power supply voltage and temperature.

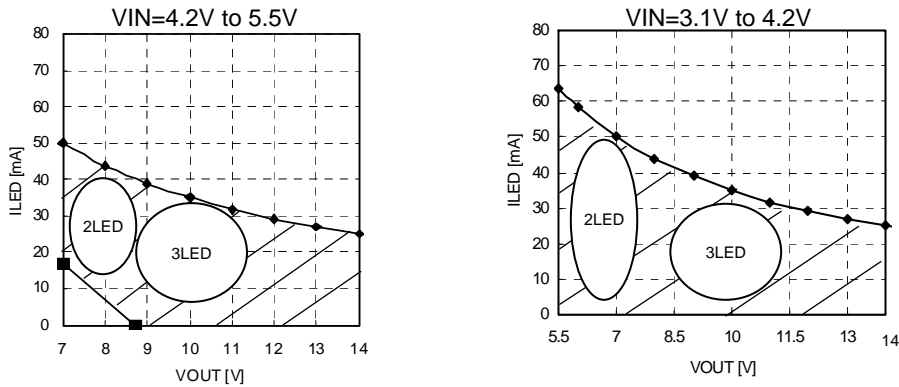

Figure 25. LED Setting range of LED current

●Selection of External Parts

Recommended external parts are as shown below.

• Coil

Value	Tolerance	Manufacturer	Product number	Size (mm)			DCR(Ω)
				W	L	H	
22µH	±10%	MURATA	LQH32CN220K53	2.5	3.2	1.55	0.71
22µH	±20%	TDK	VLF3012AT220MR33	2.6	2.8	1.2	0.66
22µH	±20%	Coil Craft	DO1608	4.45	6.6	2.92	0.37
22µH	±20%	TDK	VLF3010AT220MR33	2.6	2.8	1.0	1.30

Please refer to the reference data of p.4, p.5 for the change in the efficiency when the coil is changed.

• Capacitor

Value	Manufacturer	Product number	Size (mm)			Temperature range
			L	W	H	
<CIN>						
1µF	MURATA	GRM188B11A105K	1.6	0.8	0.8	-25°C to +85°C
<COU2>						
1µF	MURATA	GRM188B31E105K	1.6	0.8	0.8	-25°C to +85°C

• Resistor

Value	Tolerance	Manufacturer	Product number	Size (mm)		
				L	W	H
<RFB>						
24Ω	±1%	ROHM	MCR006YZPF24R0	0.6	0.3	0.23

The coil is the part that is most influential to efficiency. Select the coil whose direct current resistor (DCR) and current - inductance characteristic is excellent. The BD6071HFN is designed for the inductance value of $22\mu\text{H}$. Do not use other inductance value. Select a capacitor of ceramic type with excellent frequency and temperature characteristics. Further, select Capacitor to be used for CIN/COUT with small direct current resistance, and pay sufficient attention to the PCB layout shown in the next page.

●PCB Layout

In order to make the most of the performance of this IC, its PCB layout is very important. Characteristics such as efficiency and ripple and the likes change greatly with layout, which please note carefully.

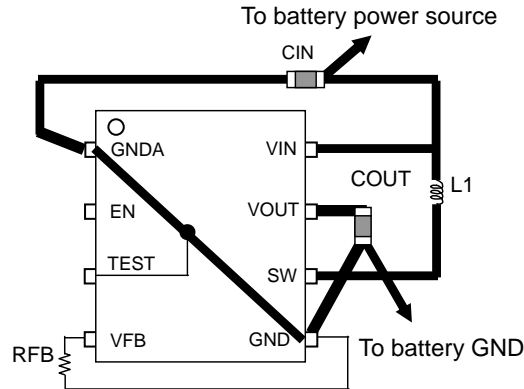

Figure 26. PCB Layout Image

Connect the input bypass capacitor CIN nearest to between VIN and GND pin, as shown in the upper diagram. Thereby, the input voltage ripple of the IC can be reduced. And, connect the output capacitor COUT nearest to between VOUT and GND pin. Thereby, the output voltage ripple of the IC can be reduced. Connect the current setting RFB nearest to VFB pin. Connect the GND connection side of RFB directly to GND pin. When those pins are not connected directly near the chip, influence is given to the performance of BD6071HFN and may limit the current drive performance. As for the wire to the inductor, make its resistance component small so as to reduce electric power consumption and increase the entire efficiency. And keep the pins that are subject to the influence like VFB pin away from the wire to SW.

<Heat radiation PAD of back side>

PAD is used for improving the efficiency of IC heat radiation. Solder PAD to GND pin (analog ground). Moreover, connect ground plane (GND) of board using via as shown in the patterns of next page. The efficiency of heat radiation improves according to the area of ground plane (GND).

The PCB layout in consideration of these is shown in the Figure 28.

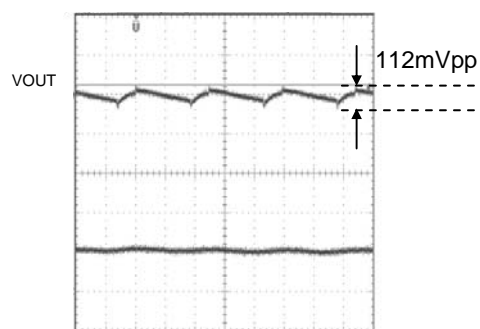

(VIN=3.6V, Ta=25°C, VOUT=14V, 20mA Load)

Figure 27. Output noise

●Recommended PCB Layout

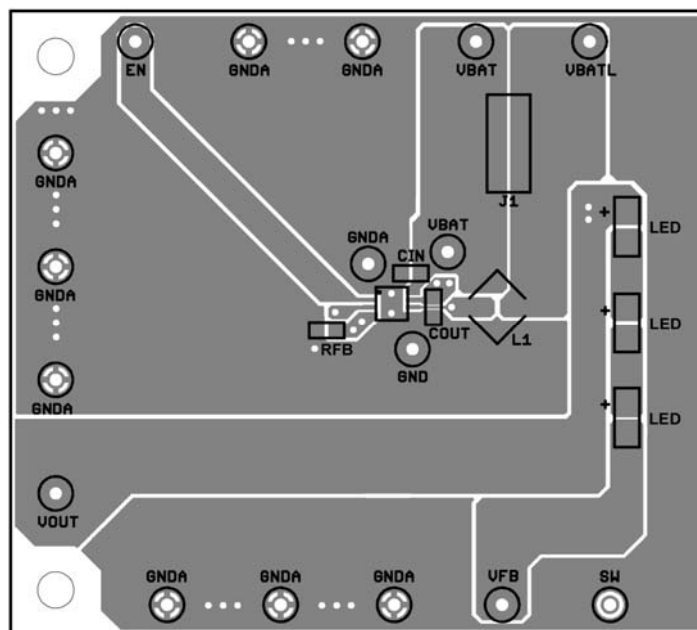

Front surface (Top view)

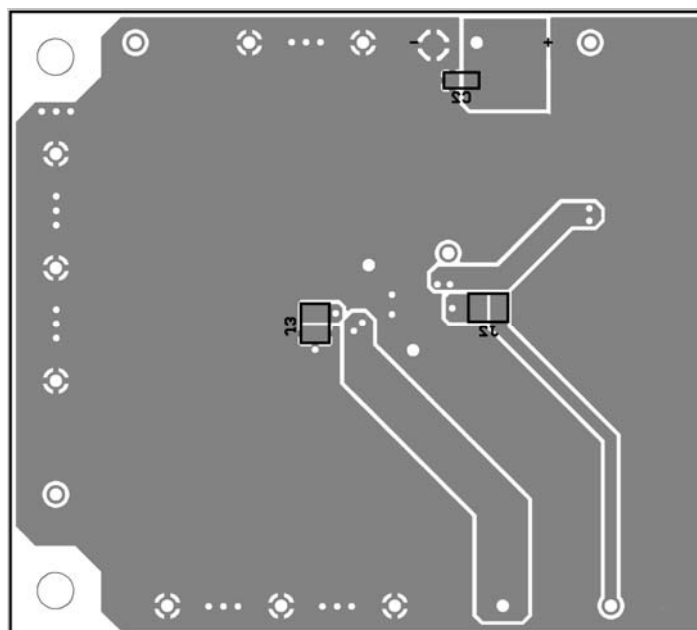

Bottom surface (Top view)

Figure 28. PCB Layout

●Attention Point of PCB Layout

In PCB design, the wiring of power supply line should be low Impedance, and put the bypass capacitor if necessary. Especially the wiring impedance must be lower around the DC/DC converter.

●About Heat Loss

In heat design, operate the DC/DC converter in the following condition.
(The following temperature is a guarantee temperature, so consider the margin.)

1. Periphery temperature T_a must be less than 85°C .
2. The loss of IC must be less than dissipation P_d .

●Operational Notes

- 1) Absolute Maximum Ratings
An excess in the absolute maximum ratings, such as supply voltage, temperature range of operating conditions, etc., can break down devices, thus making impossible to identify breaking mode such as a short circuit or an open circuit. If any special mode exceeding the absolute maximum ratings is assumed, consideration should be given to take physical safety measures including the use of fuses, etc.
- 2) Operating conditions
These conditions represent a range within which characteristics can be provided approximately as expected. The electrical characteristics are guaranteed under the conditions of each parameter.
- 3) Reverse connection of power supply connector
The reverse connection of power supply connector can break down ICs. Take protective measures against the breakdown due to the reverse connection, such as mounting an external diode between the power supply and the IC's power supply terminal.
- 4) Power supply line
Design PCB pattern to provide low impedance for the wiring between the power supply and the GND lines. In this regard, for the digital block power supply and the analog block power supply, even though these power supplies has the same level of potential, separate the power supply pattern for the digital block from that for the analog block, thus suppressing the diffraction of digital noises to the analog block power supply resulting from impedance common to the wiring patterns. For the GND line, give consideration to design the patterns in a similar manner. Furthermore, for all power supply terminals to ICs, mount a capacitor between the power supply and the GND terminal. At the same time, in order to use an electrolytic capacitor, thoroughly check to be sure the characteristics of the capacitor to be used present no problem including the occurrence of capacity dropout at a low temperature, thus determining the constant.
- 5) GND voltage
Make setting of the potential of the GND terminal so that it will be maintained at the minimum in any operating state. Furthermore, check to be sure no terminals are at a potential lower than the GND voltage including an actual electric transient.
- 6) Short circuit between terminals and erroneous mounting
In order to mount ICs on a set PCB, pay thorough attention to the direction and offset of the ICs. Erroneous mounting can break down the ICs. Furthermore, if a short circuit occurs due to foreign matters entering between terminals or between the terminal and the power supply or the GND terminal, the ICs can break down.
- 7) Operation in strong electromagnetic field
Be noted that using ICs in the strong electromagnetic field can malfunction them.
- 8) Inspection with set PCB
On the inspection with the set PCB, if a capacitor is connected to a low-impedance IC terminal, the IC can suffer stress. Therefore, be sure to discharge from the set PCB by each process. Furthermore, in order to mount or dismount the set PCB to/from the jig for the inspection process, be sure to turn OFF the power supply and then mount the set PCB to the jig. After the completion of the inspection, be sure to turn OFF the power supply and then dismount it from the jig. In addition, for protection against static electricity, establish a ground for the assembly process and pay thorough attention to the transportation and the storage of the set PCB.
- 9) Input terminals
In terms of the construction of IC, parasitic elements are inevitably formed in relation to potential. The operation of the parasitic element can cause interference with circuit operation, thus resulting in a malfunction and then breakdown of the input terminal. Therefore, pay thorough attention not to handle the input terminals, such as to apply to the input terminals a voltage lower than the GND respectively, so that any parasitic element will operate. Furthermore, do not apply a voltage to the input terminals when no power supply voltage is applied to the IC. In addition, even if the power supply voltage is applied, apply to the input terminals a voltage lower than the power supply voltage or within the guaranteed value of electrical characteristics.
- 10) Ground wiring pattern
If small-signal GND and large-current GND are provided, It will be recommended to separate the large-current GND pattern from the small-signal GND pattern and establish a single ground at the reference point of the set PCB so that resistance to the wiring pattern and voltage fluctuations due to a large current will cause no fluctuations in voltages of the small-signal GND. Pay attention not to cause fluctuations in the GND wiring pattern of external parts as well.
- 11) External capacitor
In order to use a ceramic capacitor as the external capacitor, determine the constant with consideration given to a degradation in the nominal capacitance due to DC bias and changes in the capacitance due to temperature, etc.
- 12) Thermal shutdown circuit (TSD)
When junction temperatures become 175°C (Typ.) or higher, the thermal shutdown circuit operates and turns a switch OFF. The thermal shutdown circuit, which is aimed at isolating the LSI from thermal runaway as much as possible, is not aimed at the protection or guarantee of the LSI. Therefore, do not continuously use the LSI with this circuit operating or use the LSI assuming its operation.
- 13) Thermal design
Perform thermal design in which there are adequate margins by taking into account the permissible dissipation (Pd) in actual states of use.
- 14) Selection of coil
Select the low DCR inductors to decrease power loss for DC/DC converter.

●Ordering Information



●Marking Diagram

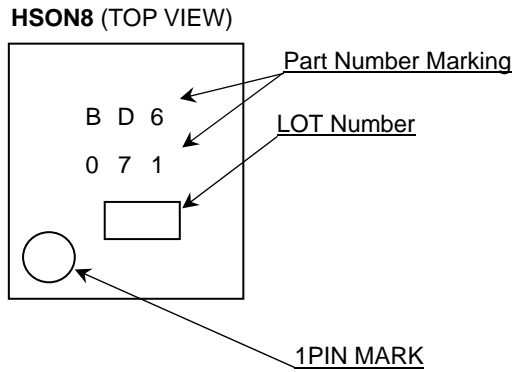

●Physical Dimensions Tape and Reel Information

HSON8

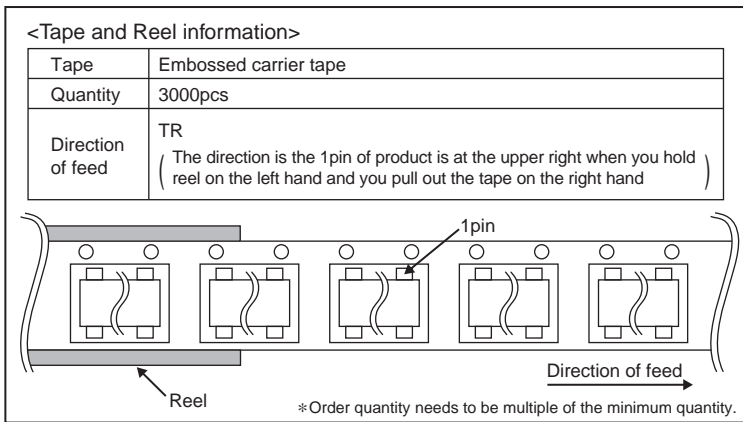
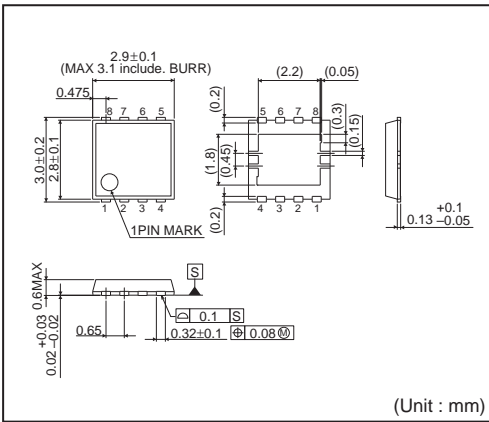

Status of this document

The Japanese version of this document is formal specification. A customer may use this translation version only for a reference to help reading the formal version.

If there are any differences in translation version of this document formal version takes priority.

●Revision History

Date	Revision	Changes
12.Oct.2012	001	New Release

Notice

Precaution on using ROHM Products

- Our Products are designed and manufactured for application in ordinary electronic equipments (such as AV equipment, OA equipment, telecommunication equipment, home electronic appliances, amusement equipment, etc.). If you intend to use our Products in devices requiring extremely high reliability (such as medical equipment ^(Note 1), transport equipment, traffic equipment, aircraft/spacecraft, nuclear power controllers, fuel controllers, car equipment including car accessories, safety devices, etc.) and whose malfunction or failure may cause loss of human life, bodily injury or serious damage to property ("Specific Applications"), please consult with the ROHM sales representative in advance. Unless otherwise agreed in writing by ROHM in advance, ROHM shall not be in any way responsible or liable for any damages, expenses or losses incurred by you or third parties arising from the use of any ROHM's Products for Specific Applications.

(Note1) Medical Equipment Classification of the Specific Applications

JAPAN	USA	EU	CHINA
CLASS III	CLASS III	CLASS II b	CLASS III
CLASS IV		CLASS III	

- ROHM designs and manufactures its Products subject to strict quality control system. However, semiconductor products can fail or malfunction at a certain rate. Please be sure to implement, at your own responsibilities, adequate safety measures including but not limited to fail-safe design against the physical injury, damage to any property, which a failure or malfunction of our Products may cause. The following are examples of safety measures:
 - Installation of protection circuits or other protective devices to improve system safety
 - Installation of redundant circuits to reduce the impact of single or multiple circuit failure
- Our Products are designed and manufactured for use under standard conditions and not under any special or extraordinary environments or conditions, as exemplified below. Accordingly, ROHM shall not be in any way responsible or liable for any damages, expenses or losses arising from the use of any ROHM's Products under any special or extraordinary environments or conditions. If you intend to use our Products under any special or extraordinary environments or conditions (as exemplified below), your independent verification and confirmation of product performance, reliability, etc. prior to use, must be necessary:
 - Use of our Products in any types of liquid, including water, oils, chemicals, and organic solvents
 - Use of our Products outdoors or in places where the Products are exposed to direct sunlight or dust
 - Use of our Products in places where the Products are exposed to sea wind or corrosive gases, including Cl₂, H₂S, NH₃, SO₂, and NO₂
 - Use of our Products in places where the Products are exposed to static electricity or electromagnetic waves
 - Use of our Products in proximity to heat-producing components, plastic cords, or other flammable items
 - Sealing or coating our Products with resin or other coating materials
 - Use of our Products without cleaning residue of flux (even if you use no-clean type fluxes, cleaning residue of flux is recommended); or Washing our Products by using water or water-soluble cleaning agents for cleaning residue after soldering
 - Use of the Products in places subject to dew condensation
- The Products are not subject to radiation-proof design.
- Please verify and confirm characteristics of the final or mounted products in using the Products.
- In particular, if a transient load (a large amount of load applied in a short period of time, such as pulse. is applied, confirmation of performance characteristics after on-board mounting is strongly recommended. Avoid applying power exceeding normal rated power; exceeding the power rating under steady-state loading condition may negatively affect product performance and reliability.
- De-rate Power Dissipation (Pd) depending on Ambient temperature (Ta). When used in sealed area, confirm the actual ambient temperature.
- Confirm that operation temperature is within the specified range described in the product specification.
- ROHM shall not be in any way responsible or liable for failure induced under deviant condition from what is defined in this document.

Precaution for Mounting / Circuit board design

- When a highly active halogenous (chlorine, bromine, etc.) flux is used, the residue of flux may negatively affect product performance and reliability.
- In principle, the reflow soldering method must be used; if flow soldering method is preferred, please consult with the ROHM representative in advance.

For details, please refer to ROHM Mounting specification

Precautions Regarding Application Examples and External Circuits

1. If change is made to the constant of an external circuit, please allow a sufficient margin considering variations of the characteristics of the Products and external components, including transient characteristics, as well as static characteristics.
2. You agree that application notes, reference designs, and associated data and information contained in this document are presented only as guidance for Products use. Therefore, in case you use such information, you are solely responsible for it and you must exercise your own independent verification and judgment in the use of such information contained in this document. ROHM shall not be in any way responsible or liable for any damages, expenses or losses incurred by you or third parties arising from the use of such information.

Precaution for Electrostatic

This Product is electrostatic sensitive product, which may be damaged due to electrostatic discharge. Please take proper caution in your manufacturing process and storage so that voltage exceeding the Products maximum rating will not be applied to Products. Please take special care under dry condition (e.g. Grounding of human body / equipment / solder iron, isolation from charged objects, setting of Ionizer, friction prevention and temperature / humidity control).

Precaution for Storage / Transportation

1. Product performance and soldered connections may deteriorate if the Products are stored in the places where:
 - [a] the Products are exposed to sea winds or corrosive gases, including Cl₂, H₂S, NH₃, SO₂, and NO₂
 - [b] the temperature or humidity exceeds those recommended by ROHM
 - [c] the Products are exposed to direct sunshine or condensation
 - [d] the Products are exposed to high Electrostatic
2. Even under ROHM recommended storage condition, solderability of products out of recommended storage time period may be degraded. It is strongly recommended to confirm solderability before using Products of which storage time is exceeding the recommended storage time period.
3. Store / transport cartons in the correct direction, which is indicated on a carton with a symbol. Otherwise bent leads may occur due to excessive stress applied when dropping of a carton.
4. Use Products within the specified time after opening a humidity barrier bag. Baking is required before using Products of which storage time is exceeding the recommended storage time period.

Precaution for Product Label

QR code printed on ROHM Products label is for ROHM's internal use only.

Precaution for Disposition

When disposing Products please dispose them properly using an authorized industry waste company.

Precaution for Foreign Exchange and Foreign Trade act

Since our Products might fall under controlled goods prescribed by the applicable foreign exchange and foreign trade act, please consult with ROHM representative in case of export.

Precaution Regarding Intellectual Property Rights

1. All information and data including but not limited to application example contained in this document is for reference only. ROHM does not warrant that foregoing information or data will not infringe any intellectual property rights or any other rights of any third party regarding such information or data. ROHM shall not be in any way responsible or liable for infringement of any intellectual property rights or other damages arising from use of such information or data.:
2. No license, expressly or implied, is granted hereby under any intellectual property rights or other rights of ROHM or any third parties with respect to the information contained in this document.

Other Precaution

1. This document may not be reprinted or reproduced, in whole or in part, without prior written consent of ROHM.
2. The Products may not be disassembled, converted, modified, reproduced or otherwise changed without prior written consent of ROHM.
3. In no event shall you use in any way whatsoever the Products and the related technical information contained in the Products or this document for any military purposes, including but not limited to, the development of mass-destruction weapons.
4. The proper names of companies or products described in this document are trademarks or registered trademarks of ROHM, its affiliated companies or third parties.

General Precaution

1. Before you use our Products, you are requested to carefully read this document and fully understand its contents. ROHM shall not be in any way responsible or liable for failure, malfunction or accident arising from the use of any ROHM's Products against warning, caution or note contained in this document.
2. All information contained in this document is current as of the issuing date and subject to change without any prior notice. Before purchasing or using ROHM's Products, please confirm the latest information with a ROHM sales representative.
3. The information contained in this document is provided on an "as is" basis and ROHM does not warrant that all information contained in this document is accurate and/or error-free. ROHM shall not be in any way responsible or liable for any damages, expenses or losses incurred by you or third parties resulting from inaccuracy or errors of or concerning such information.

Mouser Electronics

Authorized Distributor

Click to View Pricing, Inventory, Delivery & Lifecycle Information:

[ROHM Semiconductor:](#)

[BD6071HFN-TR](#)



Компания «ЭлектроПласт» предлагает заключение долгосрочных отношений при поставках импортных электронных компонентов на взаимовыгодных условиях!

Наши преимущества:

- Оперативные поставки широкого спектра электронных компонентов отечественного и импортного производства напрямую от производителей и с крупнейших мировых складов;
- Поставка более 17-ти миллионов наименований электронных компонентов;
- Поставка сложных, дефицитных, либо снятых с производства позиций;
- Оперативные сроки поставки под заказ (от 5 рабочих дней);
- Экспресс доставка в любую точку России;
- Техническая поддержка проекта, помощь в подборе аналогов, поставка прототипов;
- Система менеджмента качества сертифицирована по Международному стандарту ISO 9001;
- Лицензия ФСБ на осуществление работ с использованием сведений, составляющих государственную тайну;
- Поставка специализированных компонентов (Xilinx, Altera, Analog Devices, Intersil, Interpoint, Microsemi, Aeroflex, Peregrine, Syfer, Eurofarad, Texas Instrument, Miteq, Cobham, E2V, MA-COM, Hittite, Mini-Circuits, General Dynamics и др.);

Помимо этого, одним из направлений компании «ЭлектроПласт» является направление «Источники питания». Мы предлагаем Вам помощь Конструкторского отдела:

- Подбор оптимального решения, техническое обоснование при выборе компонента;
- Подбор аналогов;
- Консультации по применению компонента;
- Поставка образцов и прототипов;
- Техническая поддержка проекта;
- Защита от снятия компонента с производства.



Как с нами связаться

Телефон: 8 (812) 309 58 32 (многоканальный)

Факс: 8 (812) 320-02-42

Электронная почта: org@eplast1.ru

Адрес: 198099, г. Санкт-Петербург, ул. Калинина, дом 2, корпус 4, литера А.