

Omron STI

Application Support

Thank you for your interest in Omron STI products.

Please contact Omron STI with your application questions.

Support Engineers are available at our USA headquarters from 4:00 a.m. until 5:00 p.m. Pacific Time to answer your technical questions and provide application assistance. **Simply dial 1/888/510-4357 or 1/510/608-3400 and a support engineer will be happy to assist you.**



Information can also be obtained 24 hours a day via our **Website** at www.sti.com or www.omron.ca.

Turn the page for detailed

**Product
Information.**



OMRON SCIENTIFIC TECHNOLOGIES, INC.

USA Headquarters
6550 Dumbarton Circle
Fremont, CA 94555-3605
Tel: 1/510/608-3400
Fax: 1/510/744-1442
Email: sales@sti.com
www.sti.com

Omron Canada, Inc.
885 Milner Avenue
Toronto, Ontario M1B 5V8
Tel: 1/416/286-6465
Fax: 1/416/286-6648
Email: askomron@omron.com
www.omron.ca

Slim Safety Door Switch

D4GS-N

CSM_D4GS-N_DS_E_2_1

Slim Safety Door Switches with IP67 Rating

- Slim design with a width of only 17 mm (three-contact models).
- Reversible design allowing either front or rear mounting.
- Built-in Switches with two- or three-terminal contact construction are available.
- Operation Key with rubber mounting hole to absorb vibration and shock.
- IP67 degree of protection.

 Be sure to read the "Safety Precautions" on page 8 and the "Precautions for All Safety Door Switches".



Model Number Structure

Model Number Legend

Switch

D4GS-N□□-□
1 2 3

- Built-in Switch**
 - 1NC/1NO (slow-action)
 - 2NC (slow-action)
 - 2NC/1NO (slow-action)
 - 3NC (slow-action)
- Direction of Operation Key Insertion**
 - R: Horizontal
 - T: Vertical
- Cable Length**
 - Blank: 1 m
 - 3: 3 m
 - 5: 5 m

Operation Key

D4GS-NK□
1

- Operation Key Type**
 - 1: Horizontal mounting
 - 2: Vertical mounting
 - 4: Adjustable mounting (Vertical)

Ordering Information



List of Models

Switches (Operation Keys are sold separately.)

 : Models with certified direct opening contacts.

Appearance	Direction of Operation Key insertion	Cable length	1NC/1NO (Slow-action)	2NC (Slow-action)	2NC/1NO (Slow-action)	3NC (Slow-action)
	Horizontal	1 m	D4GS-N1R	D4GS-N2R	D4GS-N3R	D4GS-N4R
		3 m	D4GS-N1R-3	D4GS-N2R-3	D4GS-N3R-3	D4GS-N4R-3
		5 m	D4GS-N1R-5	D4GS-N2R-5	D4GS-N3R-5	D4GS-N4R-5
	Vertical	1 m	D4GS-N1T	D4GS-N2T	D4GS-N3T	D4GS-N4T
		3 m	D4GS-N1T-3	D4GS-N2T-3	D4GS-N3T-3	D4GS-N4T-3
		5 m	D4GS-N1T-5	D4GS-N2T-5	D4GS-N3T-5	D4GS-N4T-5

Operation Keys

Type	Model	Type	Model
Horizontal mounting 	D4GS-NK1	Adjustable mounting (Vertical) 	D4GS-NK4
Vertical mounting 	D4GS-NK2		

Specifications

Standards and EC Directives

Conforms to the following EC Directives:

- Machinery Directive
- Low Voltage Directive
- EN1088
- EN60204-1

Certified Standards

Certification body	Standard	File No.
TÜV Rheinland	EN60947-5-1 (certified direct opening) GS-ET-15	J2051125
UL *	UL508 CSA C22.2 No. 14	E76675
CQC (CCC)	GB14048.5	2003010305064262

* Certification for CSA C22.2 No. 14 is authorized by the UL mark.

Certified Standard Ratings

TÜV (EN60947-5-1), CCC (GB14048.5)

Item	Utilization category	AC-15	DC-13
Rated operating current (I _e)		0.75 A	0.27 A
Rated operating voltage (U _e)		240 V	250 V

Note: Use a 10 A fuse type gI or gG that conforms to IEC60269 as a short-circuit protection device.

UL/CSA (UL508, CSA C22.2 No. 14)

C300

Rated voltage	Carry current	Current (A)		Volt-amperes (VA)	
		Make	Break	Make	Break
120 VAC	2.5 A	15	1.5	1,800	180
240 VAC		7.5	0.75		

Q300

Rated voltage	Carry current	Current (A)		Volt-amperes (VA)	
		Make	Break	Make	Break
125 VDC	2.5 A	0.55	0.55	69	69
250 VDC		0.27	0.27		

Characteristics

Degree of protection *1		IP67 (EN60947-5-1)
Durability *2	Mechanical	1,000,000 operations min.
	Electrical	100,000 operations min. (1 A resistive load at 125 VAC) *3
Operating speed		0.1 to 0.5 m/s
Operating frequency		30 operations/minute max.
Direct opening force *4		60 N min.
Direct opening travel *4		10 mm min.
Contact resistance		300 mΩ max. (with 1 m cable)
Minimum applicable load *5		Resistive load of 4 mA at 24 VDC (N-level reference value)
Rated insulation voltage (U_i)		250 V
Rated frequency		50/60 Hz
Protection against electric shock		Class II (double insulation) (IEC60536)
Pollution degree (operating environment)		3 (EN60947-5-1)
Impulse withstand voltage (EN60947-5-1)	Between terminals of same polarity	2.5 kV
	Between terminals of different polarity	4 kV
	Between each terminal and non-current carrying metallic parts	6 kV
Insulation resistance		100 MΩ min. (at 500 VDC) between terminals of the same polarities, between terminals of different polarities, and between each terminal and non-current carrying metal parts
Contact gap		2 × 2 mm min.
Vibration resistance	Malfunction	10 to 55 Hz, 0.35 mm single amplitude
Shock resistance	Destruction	1,000 m/s ² min.
	Malfunction	300 m/s ² min.
Conditional short-circuit current		100 A (EN60947-5-1)
Conventional free air thermal current (I_{th})		2.5 A (EN60947-5-1)
Ambient operating temperature		-30 to 70°C (with no icing)
Ambient operating humidity		95% max.
Cable		UL2464 No. 22 AWG, finishing O.D.: 7.2 mm
Weight		Approx. 120 g (D4GS-N1R, with 1 m cable)

Note: 1. The above values are initial values.

2. The Switch contacts can be used with either standard loads or microloads. Once the contacts have been used to switch a load, however, they cannot be used to switch smaller loads. The contact surfaces will become rough once they have been used and contact reliability for smaller loads may be reduced.

***1.** The degree of protection shown above is based on the test method specified in EN60947-5-1. Be sure to confirm in advance the sealing performance under the actual operating environment and conditions.

Although the switch box is protected from dust, oil, or water penetration, do not use the D4GS-N in places where dust, oil, water, or chemicals may enter through the key hole on the head, otherwise Switch damage or malfunctioning may occur.

***2.** The durability conditions are an ambient temperature of 5 to 35°C and an ambient humidity of 40% to 70%. For more details, consult your OMRON representative.

***3.** When the ambient temperature is 35°C or higher, do not apply 1 A at 125 VAC to more than one circuit.

***4.** These figures are minimum requirements for safe operation.

***5.** The value given for minimum applicable load is a reference value for microloads. The value will vary depending on factors such as the switching frequency, the ambient environment, and the reliability level. Be sure to confirm correct operation with the actual load before application.

Structure and Nomenclature

Structure

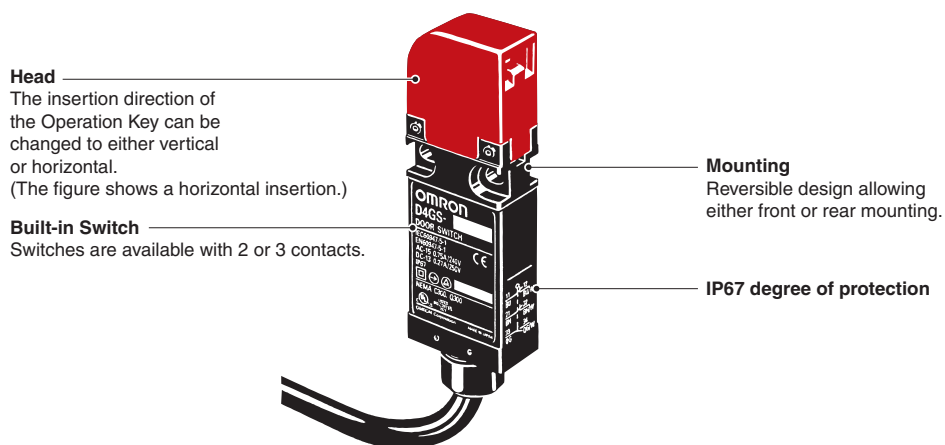

Contact Form (Diagrams Show State with Key Inserted.)

Model	Contact	Contact form	Operating pattern	Remarks
D4GS-N1□-□	1NC/1NO			Only NC contact 11-12 has a certified direct opening mechanism. The terminals 11-12 and 33-34 can be used as unlike poles.
D4GS-N2□-□	2NC			NC contacts 11-12 and 31-32 have a certified direct opening mechanism. The terminals 11-12 and 31-32 can be used as unlike poles.
D4GS-N3□-□	2NC/1NO			Only NC contacts 11-12 and 21-22 have a certified direct opening mechanism. The terminals 11-12, 21-22 and 33-34 can be used as unlike poles.
D4GS-N4□-□	3NC			NC contacts 11-12, 21-22 and 31-32 have a certified direct opening mechanism. The terminals 11-12, 21-22 and 31-32 can be used as unlike poles.

Note: The terminal numbers are according to EN50013, and the contact symbols are according to IEC 60947-5-1.

Dimensions and Operating Characteristics

Switches

D4GS-N□R-□



Operating characteristics

Key insertion force	15 N max.
Key extraction force	30 N max.
Pretravel (PT)	6.8±3 mm
Movement before being locked	(22 mm)
Direct opening force	60 N min.
Direct opening stroke	10 mm min.

D4GS-N□T-□

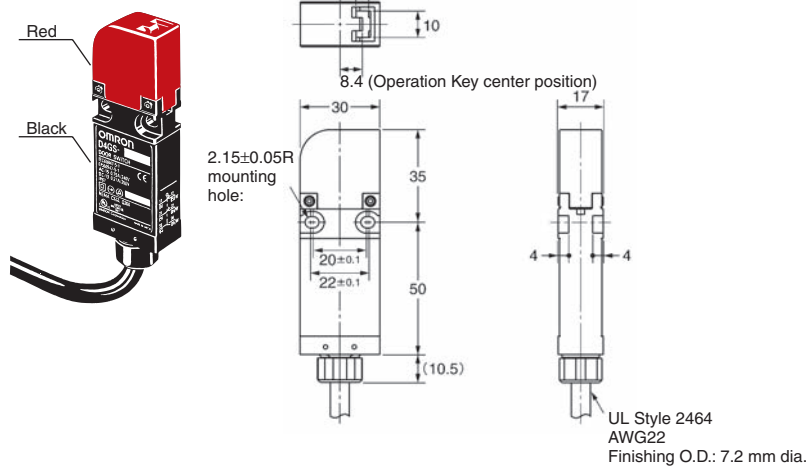

- Note: 1.** Unless otherwise specified, a tolerance of ±0.4 mm applies to all dimensions. Dimensions in parentheses are reference values.
- 2.** There are fluctuations in the contact ON/OFF timing for Switches with multiple poles (2NC, 2NC/1NO, or 3NC). Confirm performance before application.

Operation Keys

D4GS-NK1

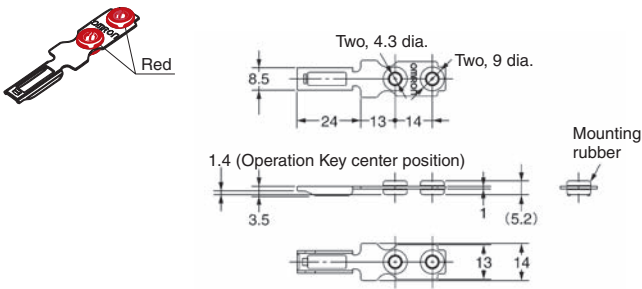

D4GS-NK2

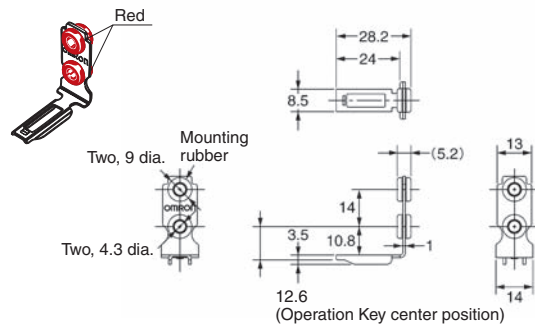

D4GS-NK4

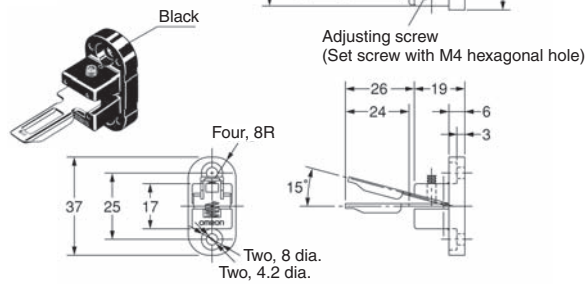

Note: Unless otherwise specified, a tolerance of ± 0.4 mm applies to all dimensions. Dimensions in parentheses are reference values.

With Operation Key Inserted

D4GS-N□R□ + D4GS-NK1

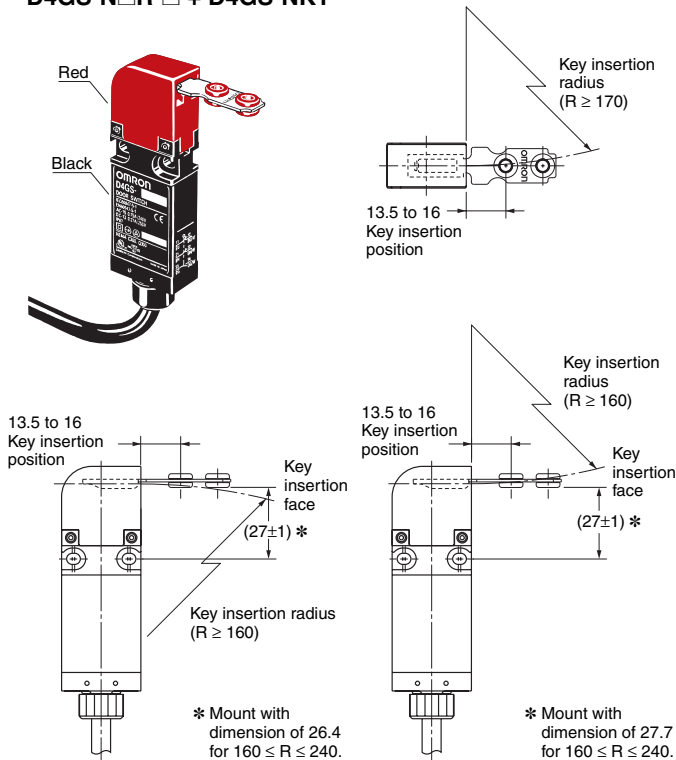

D4GS-N□T□ + D4GS-NK1

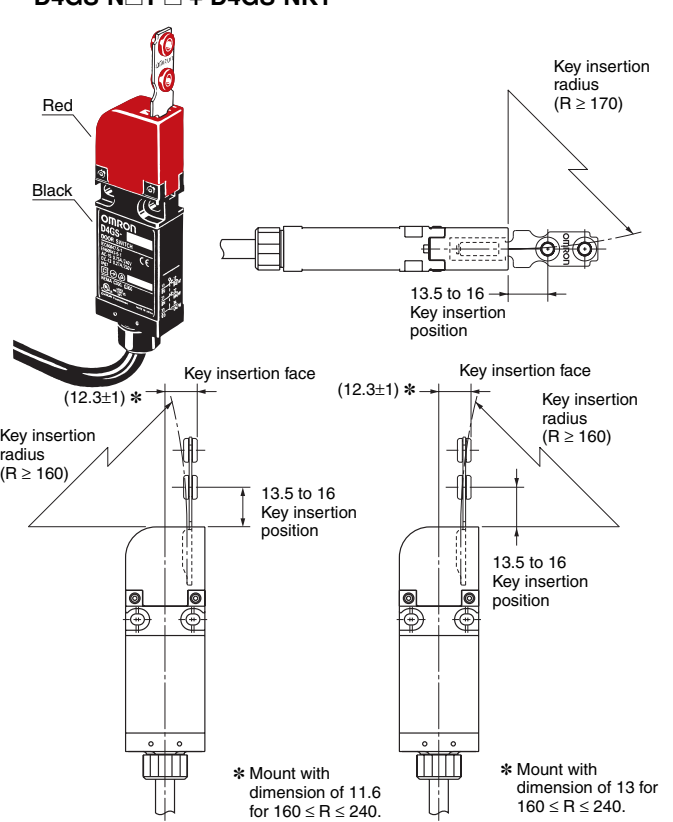

Note: Unless otherwise specified, a tolerance of ± 0.4 mm applies to all dimensions. Dimensions in parentheses are reference values.

D4GS-N□R□ + D4GS-NK2

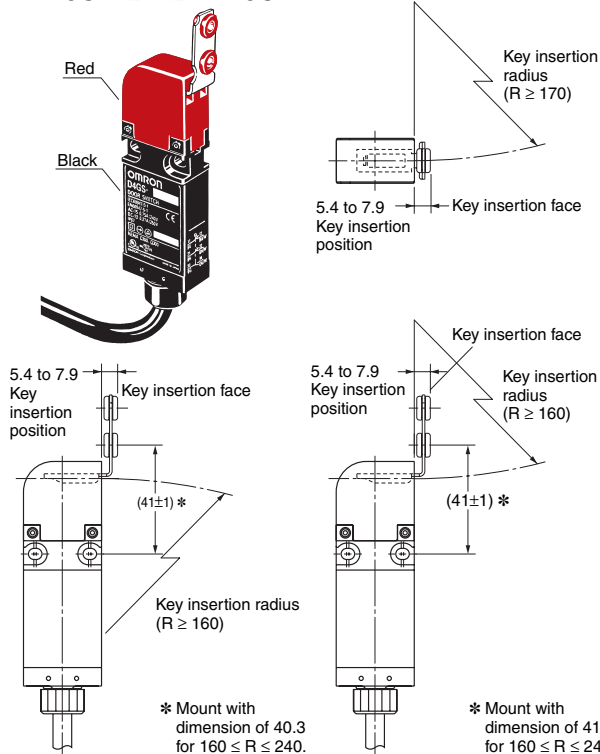

D4GS-N□T□ + D4GS-NK2

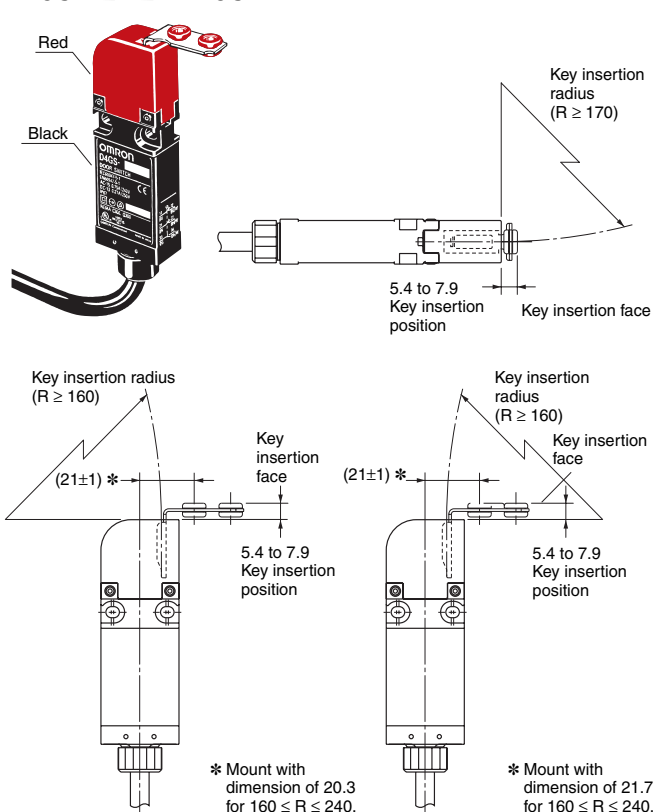

D4GS-N□R□ + D4GS-NK4

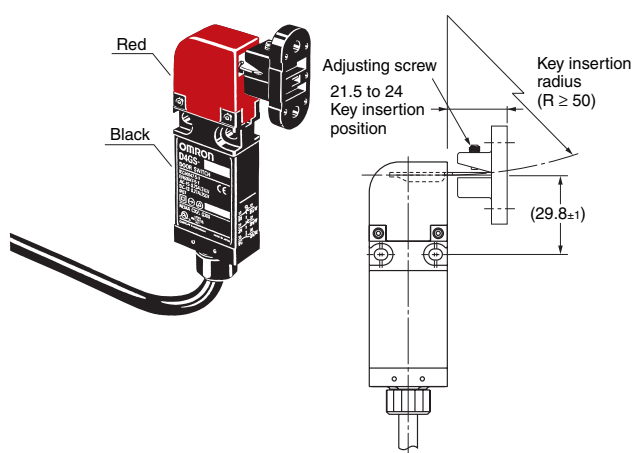

Note 1: When determining the operation key insertion radius, adjust the adjusting screw so that the tip of the operation key is positioned to the center of the key insertion hole of the Switch.

Note 2: The operation key cannot be inserted or adjusted in a direction different from the one shown above. Use the D4GS-NK1 or D4GS-NK2 if necessary.

D4GS-N□T□ + D4GS-NK4

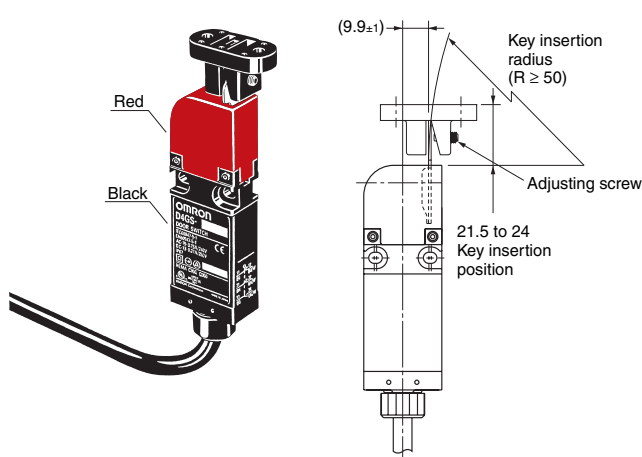

Note 1: When determining the operation key insertion radius, adjust the adjusting screw so that the tip of the operation key is positioned to the center of the key insertion hole of the Switch.

Note 2: The operation key cannot be inserted or adjusted in a direction different from the one shown above. Use the D4GS-NK1 or D4GS-NK2 if necessary.

Note: Unless otherwise specified, a tolerance of ± 0.4 mm applies to all dimensions. Dimensions in parentheses are reference values.

Safety Precautions

Refer to the “*Precautions for All Switches*” and “*Precautions for All Safety Door Switches*”.

Precautions for Safe Use

- Do not use the Switch submerged in oil or water or in locations continuously subject to splashes of oil or water. Doing so may result in oil or water entering the Switch. (The IP67 degree of protection of the Switch specifies the amount of water penetration after the Switch is submerged in water for a certain period of time.)
- Although the Switch body is protected from the ingress of dust or water, the head is not protected. Do not allow foreign substance to enter through the head. Otherwise, accelerated wear or breaking may result.
- Do not switch circuits for two or more standard loads (125 VAC, 1 A). Doing so may adversely affect insulation performance.
- Do not use the D4GS-N□ Switch or D4GS-NK□ Operation Key (rubber color: red) in combination with the D4GS-□ Switch or D4GS-K□ Operation Key (rubber color: black).

Handling Cables

- Cables must not be bent repeatedly.
- A cable is fixed with sealing materials on the bottom of the D4GS-N. When excessive force may be imposed on the cable, fix the cable with a fixing unit at the distance of 5 cm from the bottom of the D4GS-N as shown.
- When bending the cable, secure the cable with more than 45 mm bending radius so as not to cause damage to the insulator or sheath of the cable. Otherwise, fire or electrical shock may result.

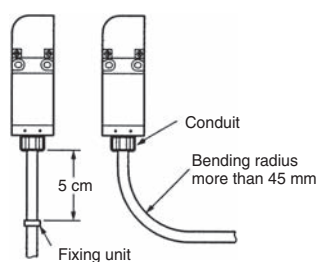

- Do not fasten or loosen the conduit at the bottom of the D4GS-N.
- When wiring, be sure not to allow a liquid such as water or oil into the tip of cable.

Stopper Installation

Do not use a Switch as a stopper.

Be sure to install a stopper as shown in the following illustration when mounting the Switch and adjust the stopper so that the Operation Key is within the setting zone.

Do not subject the Switch to a shock that exceeds the Switch's shock resistance of 1,000 m/s².

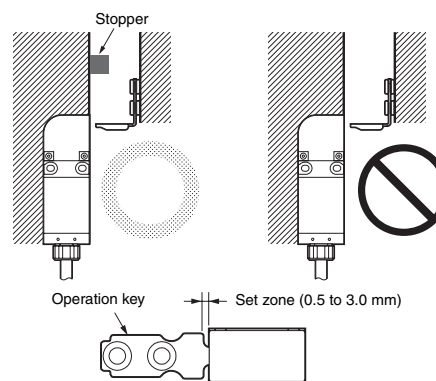

Precautions for Correct Use

The Switch contacts can be used with either standard loads or microloads. Once the contacts have been used to switch a load, however, they cannot be used to switch smaller loads. The contact surfaces will become rough once they have been used and contact reliability for smaller loads may be reduced.

Mounting Methods

Appropriate Tightening Torque

- Loose screws may result in malfunction. Tighten the screws to the specified torques.

Type	Torque	Size
Body mounting screw	0.75 to 1.15 N·m	M4 screw
Operation Key mounting screw	0.75 to 1.15 N·m	M4 screw

- Use the specified sizes of mounting screws flat or spring washers to mount the Switch and Operation Key, and tighten the screws to the proper tightening torque. To ensure safety, use screws that cannot be easily removed or another means to prevent the Switch and Operation Key from easily being removed.

Mounting Hole Dimensions for Switches

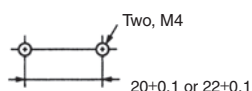

Mounting Hole Dimensions for Operation Keys

D4GS-NK1/NK2

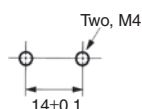

D4GS-NK4

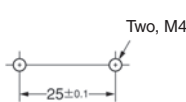

Operation Key

- As shown below, mount the Operation Key after matching the concave surface of the Operation Key with the convex surface of the insertion face.



- Depending on the conditions in which the Switch is used, the rubber of the Operation Key may deteriorate. If the rubber becomes deformed or cracked, replace it as soon as possible.

Wiring

Identifying Wires

Identify wires according to the color (with or without white lines) of the insulation on the wire.

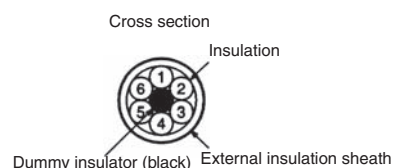

Core Insulator Colors

Blue/white, Brown/white, Orange/white, Orange, Brown, and Blue

Example: Orange/white is an orange insulator with a white line.

Terminal Numbers

- Identify terminal numbers based on the color of the insulation on the wire.
- The safety and auxiliary contacts of D4GS-N models of three-terminal contact construction and those of two-terminal contact construction are described below.
- The auxiliary contacts (orange) can be used as safety contacts.
- The safety contacts are direct opening contacts certified by EN and each of them is indicated with the mark \ominus .

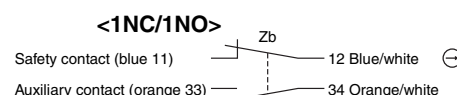

- Cut the black dummy insulator and all unused wires at the end of the external insulation sheath when wiring the cable.



Компания «ЭлектроПласт» предлагает заключение долгосрочных отношений при поставках импортных электронных компонентов на взаимовыгодных условиях!

Наши преимущества:

- Оперативные поставки широкого спектра электронных компонентов отечественного и импортного производства напрямую от производителей и с крупнейших мировых складов;
- Поставка более 17-ти миллионов наименований электронных компонентов;
- Поставка сложных, дефицитных, либо снятых с производства позиций;
- Оперативные сроки поставки под заказ (от 5 рабочих дней);
- Экспресс доставка в любую точку России;
- Техническая поддержка проекта, помощь в подборе аналогов, поставка прототипов;
- Система менеджмента качества сертифицирована по Международному стандарту ISO 9001;
- Лицензия ФСБ на осуществление работ с использованием сведений, составляющих государственную тайну;
- Поставка специализированных компонентов (Xilinx, Altera, Analog Devices, Intersil, Interpoint, Microsemi, Aeroflex, Peregrine, Syfer, Eurofarad, Texas Instrument, Miteq, Cobham, E2V, MA-COM, Hittite, Mini-Circuits, General Dynamics и др.);

Помимо этого, одним из направлений компании «ЭлектроПласт» является направление «Источники питания». Мы предлагаем Вам помощь Конструкторского отдела:

- Подбор оптимального решения, техническое обоснование при выборе компонента;
- Подбор аналогов;
- Консультации по применению компонента;
- Поставка образцов и прототипов;
- Техническая поддержка проекта;
- Защита от снятия компонента с производства.



Как с нами связаться

Телефон: 8 (812) 309 58 32 (многоканальный)

Факс: 8 (812) 320-02-42

Электронная почта: org@eplast1.ru

Адрес: 198099, г. Санкт-Петербург, ул. Калинина, дом 2, корпус 4, литера А.