

NHD-C12864WC-FSW-FBW-3V3-M

COG (Chip-On-Glass) Liquid Crystal Display Module

NHD-	Newhaven Display
C12864-	128 x 64 pixels
WM-	Model
F-	Transflective
SW-	Side White LED backlight
F-	FSTN (+)
B-	6:00 view
W-	Wide Temp (-20°C ~ +70°C)
3V3-	3.0V LCD, 3.0V Backlight
M-	Mounting Holes
	RoHS Compliant

Newhaven Display International, Inc.

2511 Technology Drive, Suite 101

Elgin IL, 60124

Ph: 847-844-8795

Fax: 847-844-8796

www.newhavendisplay.com

nhtech@newhavendisplay.com

nhsales@newhavendisplay.com

Document Revision History

Revision	Date	Description	Changed by
0	10/12/2010	Initial Release	MC
1	5/25/2010	Electrical characteristics updated	AK
2	4/4/2013	Backlight mating connector part number updated	AK

Functions and Features

- 128 x 64 pixels
- Built-in ST7565R controller
- Parallel/Serial interface
- 1/64 duty cycle; 1/9 bias
- RoHS Compliant

Mechanical Drawing

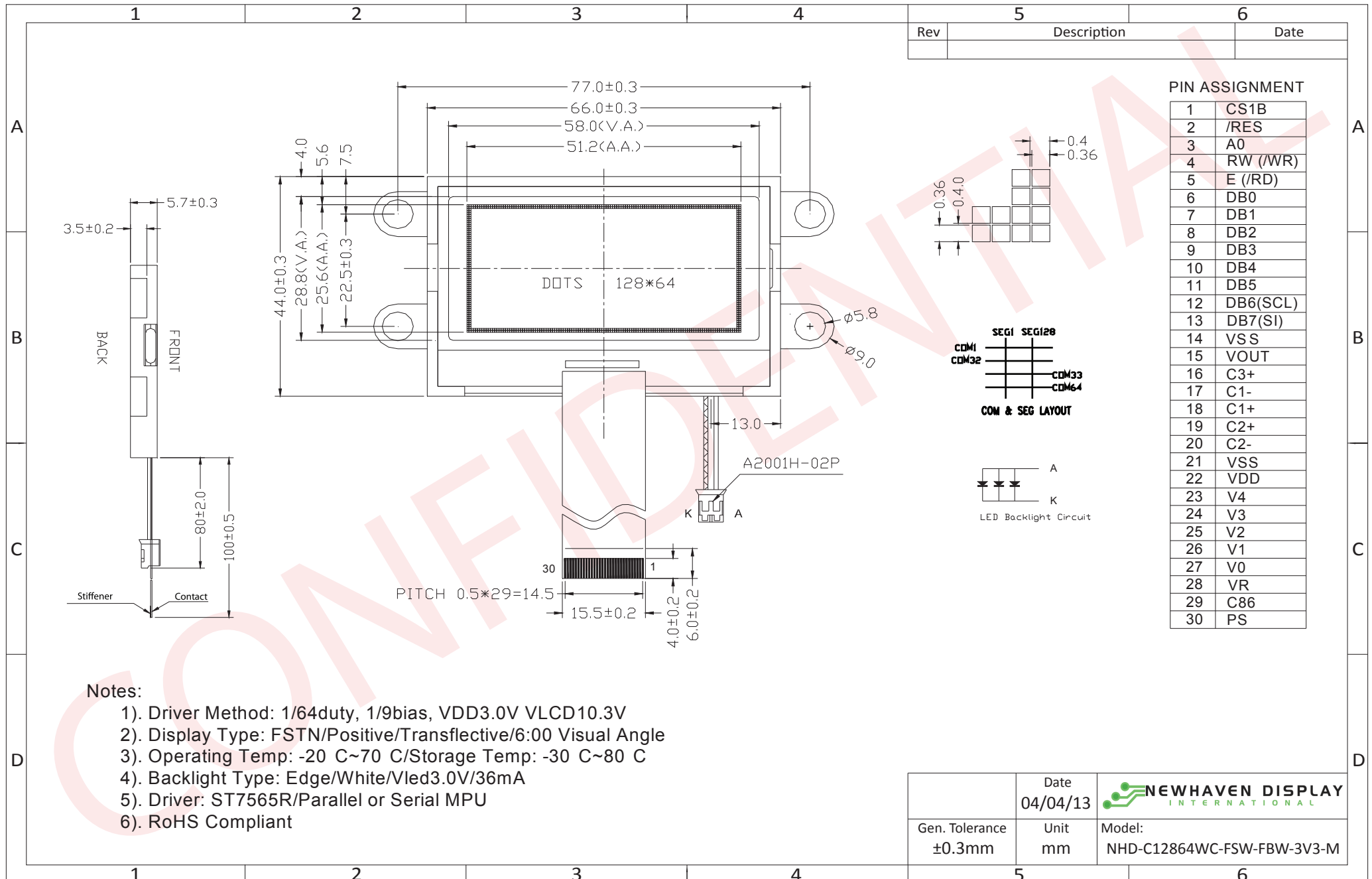

Notes:

- 1). Driver Method: 1/64duty, 1/9bias, VDD3.0V VLCD10.3V
- 2). Display Type: FSTN/Positive/Transflective/6:00 Visual Angle
- 3). Operating Temp: -20 C~70 C/Storage Temp: -30 C~80 C
- 4). Backlight Type: Edge/White/Vled3.0V/36mA
- 5). Driver: ST7565R/Parallel or Serial MPU
- 6). RoHS Compliant

	Date 04/04/13	 NEWHAVEN DISPLAY INTERNATIONAL
Gen. Tolerance ±0.3mm	Unit mm	

The drawing contained herein is the exclusive property of Newhaven Display International, Inc. and shall not be copied, reproduced, and/or disclosed in any format without permission.

Pin Description and Wiring Diagram

Pin No.	Symbol	External Connection	Function Description	
1	CS1B	MPU	Active LOW chip select	
2	/RES	MPU	Active LOW Reset signal	
3	A0	MPU	Register select signal. RS=0: Command, RS=1: Data	
4	RW (/WR)	MPU	Read/write select signal. R/W=1: Read R/W=0: Write	
5	E (/RD)	MPU	Operation enable signal. Falling edge triggered.	
6	DB0	MPU	Parallel Interface DB0-DB7: Bi-directional 8-bit data bus Serial Interface: DB0-DB5: No connect in serial mode DB6 = Serial clock DB7 = Serial data	
7	DB1	MPU		
8	DB2	MPU		
9	DB3	MPU		
10	DB4	MPU		
11	DB5	MPU		
12	DB6(SCL)	MPU		
13	DB7(SI)	MPU		
14	VSS	Power Supply		Ground (reference for voltage step-up circuit)
15	VOUT	Power Supply		Connect to 1uF cap to VSS (PIN-14)
16	CAP3+	Power Supply		Connect to 1uF cap to CAP1- (PIN-17)
17	CAP1-	Power Supply		Connect to 1uF cap to CAP3+(PIN16) and CAP1+(PIN18)
18	CAP1+	Power Supply		Connect to 1uF cap to CAP1- (PIN-17)
19	CAP2+	Power Supply	Connect to 1uF cap to CAP2- (PIN-20)	
20	CAP2-	Power Supply	Connect to 1uF cap to CAP2+ (PIN-19)	
21	VSS	Power Supply	Ground	
22	VDD	Power Supply	Power supply for LCD and logic (3.0V)	
23~27	V4~V0	Power Supply	1.0uF-2.2uF cap to VDD or VSS	
28	VR	-	No Connect	
29	C86	MPU	Select MPU interface pin. C86=H: 6800; C86=L: 8080	
30	PS	MPU	Parallel/Serial select. PS= H: Parallel; PS=L: Serial	
A		Power Supply	Power supply for LED Backlight (+3.0V)	
K		Power Supply	Ground for Backlight	

Recommended LCD connector: 0.5mm Pitch, 30 pin FFC. Molex p/n: 52892-3095

Backlight connector: A2001H-2P **Mates with:** A2001WR-2P, A2001WR-S-2P, A2001WV-2P, A2001WV-S-2P

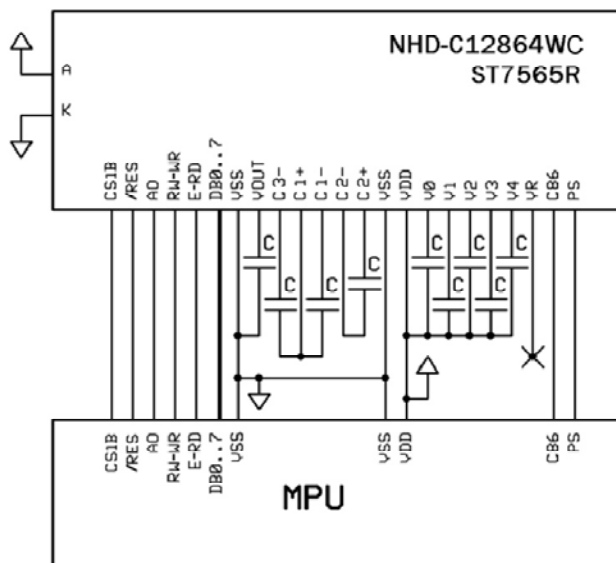

Electrical Characteristics

Item	Symbol	Condition	Min.	Typ.	Max.	Unit
Operating Temperature Range	TOP	Absolute Max	-20	-	+70	°C
Storage Temperature Range	TST	Absolute Max	-30	-	+80	°C
Supply Voltage	VDD		2.7	3.0	3.3	V
Supply Current	IDD	VDD=3.0V	-	-	0.5	mA
Supply for LCD (contrast)	VDD-V0	-	-	10.3	-	V
"H" Level input	Vih		0.8*VDD	-	VDD	V
"L" Level input	Vil		VSS	-	0.2*VDD	V
"H" Level output			0.8*VDD	-	VDD	-
"L" Level output			-	-	0.2*VDD	-
LED BKL voltage	VLED	-	-	3.0	-	V
LED BKL current	ILED	VLED=3.0	-	36	-	mA

Optical Characteristics

Item	Symbol	Condition	Min.	Typ.	Max.	Unit
Viewing Angle – Top		CR ≥ 2	-	20	-	°
Viewing Angle – Bottom			-	50	-	°
Viewing Angle – Left			-	30	-	°
Viewing Angle – Right			-	30	-	°
Contrast Ratio	CR		3	5	-	-
Response Time (rise)	Tr		-	150	250	ms
Response Time (fall)	Tf		-	150	250	ms

Controller Information

Built-in ST7565R controller.

Please download specification at http://www.newhavendisplay.com/app_notes/ST7565R.pdf

Table of Commands

Command	Command Code									Function			
	A0	/RD	/WR	D7	D6	D5	D4	D3	D2		D1	D0	
(1) Display ON/OFF	0	1	0	1	0	1	0	1	1	1	0	1	LCD display ON/OFF 0: OFF, 1: ON
(2) Display start line set	0	1	0	0	1	Display start address					0	Sets the display RAM display start line address	
(3) Page address set	0	1	0	1	0	1	Page address				0	Sets the display RAM page address	
(4) Column address set upper bit	0	1	0	0	0	0	1	Most significant column address			0	Sets the most significant 4 bits of the display RAM column address.	
Column address set lower bit				0	0	0	0	Least significant column address			0	Sets the least significant 4 bits of the display RAM column address.	
(5) Status read	0	0	1	Status			0	0	0	0	0	Reads the status data	
(6) Display data write	1	1	0	Write data						0	Writes to the display RAM		
(7) Display data read	1	0	1	Read data						0	Reads from the display RAM		
(8) ADC select	0	1	0	1	0	1	0	0	0	0	0	1	Sets the display RAM address SEG output correspondence 0: normal, 1: reverse
(9) Display normal/reverse	0	1	0	1	0	1	0	0	1	1	0	1	Sets the LCD display normal/ reverse 0: normal, 1: reverse
(10) Display all points ON/OFF	0	1	0	1	0	1	0	0	1	0	0	1	Display all points 0: normal display 1: all points ON
(11) LCD bias set	0	1	0	1	0	1	0	0	0	1	0	1	Sets the LCD drive voltage bias ratio 0: 1/9 bias, 1: 1/7 bias (ST7565R)
(12) Read-modify-write	0	1	0	1	1	1	0	0	0	0	0	0	Column address increment At write: +1 At read: 0
(13) End	0	1	0	1	1	1	0	1	1	1	0	0	Clear read/modify/write
(14) Reset	0	1	0	1	1	1	0	0	0	1	0	0	Internal reset
(15) Common output mode select	0	1	0	1	1	0	0	0	*	*	*	1	Select COM output scan direction 0: normal direction 1: reverse direction
(16) Power control set	0	1	0	0	0	1	0	1	Operating mode		0	0	Select internal power supply operating mode
(17) V ₀ voltage regulator internal resistor ratio set	0	1	0	0	0	1	0	0	Resistor ratio		0	0	Select internal resistor ratio(Rb/Ra) mode
(18) Electronic volume mode set	0	1	0	1	0	0	0	0	0	0	0	1	Set the V ₀ output voltage electronic volume register
Electronic volume register set				0	0	Electronic volume value					0		
(19) Sleep mode set	0	1	0	1	0	1	0	1	1	0	0	1	0: Sleep mode, 1: Normal mode
(20) Booster ratio set	0	1	0	1	1	1	1	1	0	0	0	0	select booster ratio 00: 2x,3x,4x 01: 5x 11: 6x
				0	0	0	0	0	0	0	step-up value		
(21) NOP	0	1	0	1	1	1	0	0	0	1	1	1	Command for non-operation
(22) Test	0	1	0	1	1	1	1	*	*	*	*	*	Command for IC test. Do not use this command

Timing Characteristics

System Bus Read/Write Characteristics 1 (For the 8080 Series MPU)

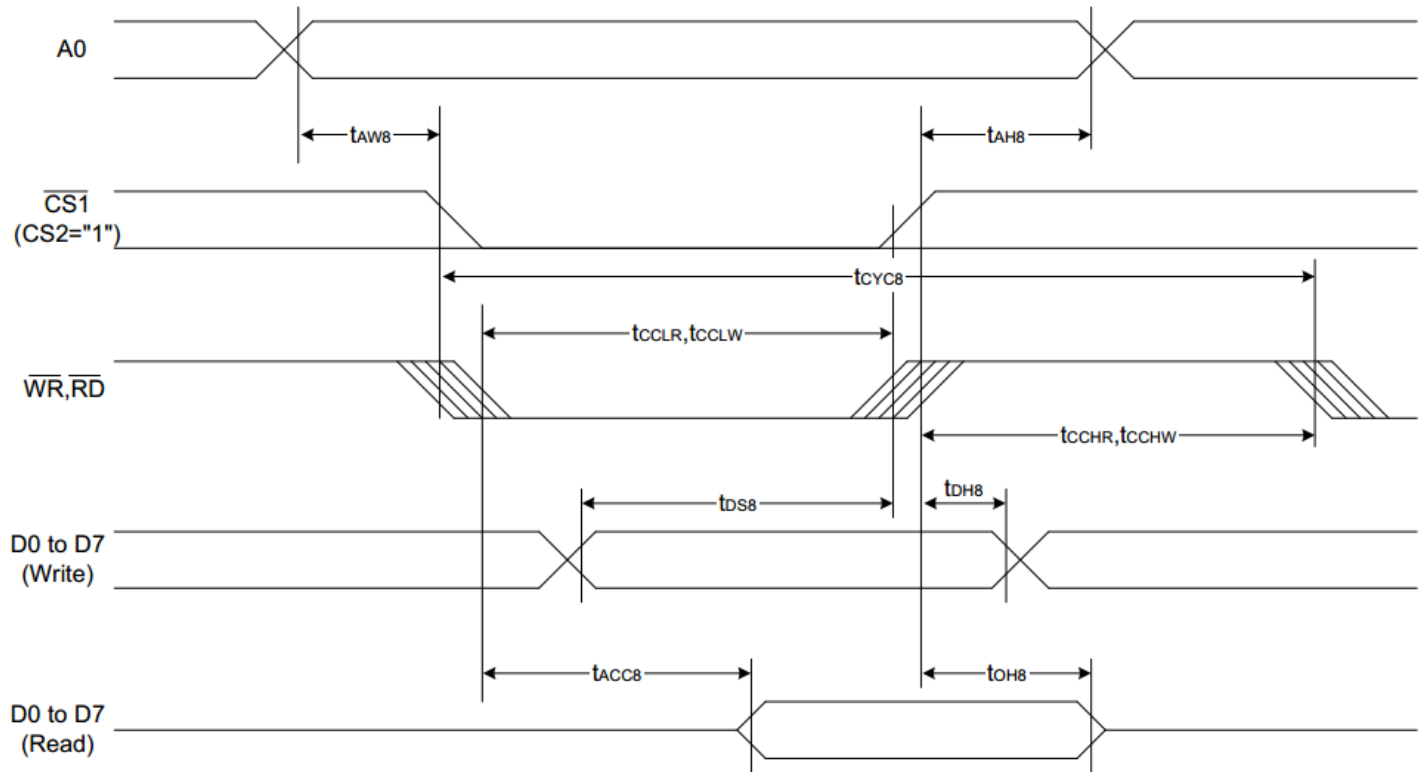

($V_{DD} = 3.3V$, $T_a = -30$ to $85^\circ C$)

Item	Signal	Symbol	Condition	Rating		Units
				Min.	Max.	
Address hold time	A0	tAH8		0	—	Ns
Address setup time		tAW8		0	—	
System cycle time		tCYC8		240	—	
Enable L pulse width (WRITE)	WR	tCCLW		80	—	
Enable H pulse width (WRITE)		tCCHW		80	—	
Enable L pulse width (READ)	RD	tCCLR		140	—	
Enable H pulse width (READ)		tCCHR		80	—	
WRITE Data setup time	D0 to D7	tDS8		40	—	
WRITE Address hold time		tDH8		0	—	
READ access time		tACC8	CL = 100 pF	—	70	
READ Output disable time		tOH8	CL = 100 pF	5	50	

System Bus Read/Write Characteristics 2 (For the 6800 Series MPU)

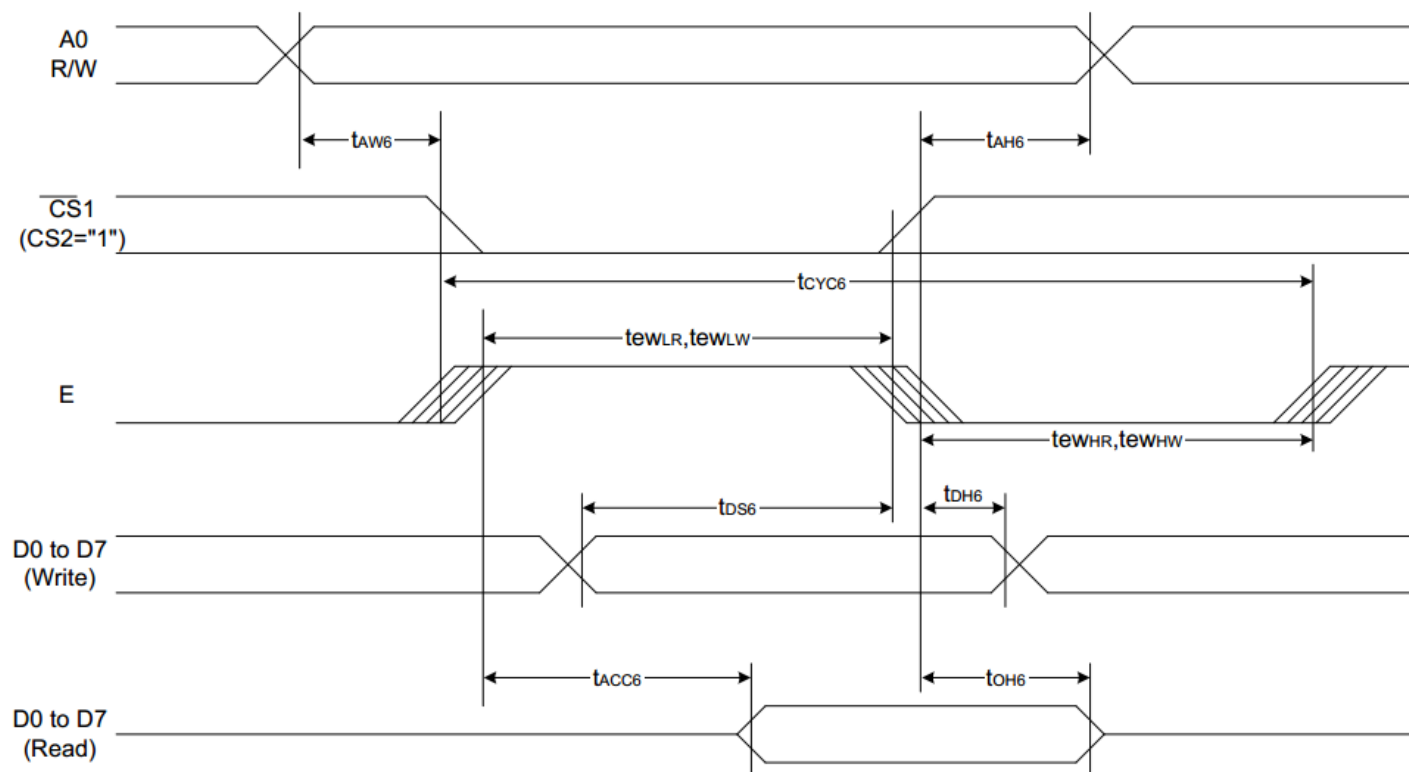

($V_{DD} = 3.3V, T_a = -30 \text{ to } 85^\circ\text{C}$)

Item	Signal	Symbol	Condition	Rating		Units
				Min.	Max.	
Address hold time	A0	t_{AH6}		0	—	ns
Address setup time		t_{AW6}		0	—	
System cycle time		t_{CYC6}		240	—	
Enable L pulse width (WRITE)	WR	t_{EWLW}		80	—	
Enable H pulse width (WRITE)		t_{EWHW}		80	—	
Enable L pulse width (READ)	RD	t_{EWLR}		80	—	
Enable H pulse width (READ)		t_{EWHR}		140	—	
WRITE Data setup time	D0 to D7	t_{DS6}		40	—	
WRITE Address hold time		t_{DH6}		0	—	
READ access time		t_{ACC6}	$C_L = 100 \text{ pF}$	—	70	
READ Output disable time		t_{OH6}	$C_L = 100 \text{ pF}$	5	50	

The 4-line SPI Interface

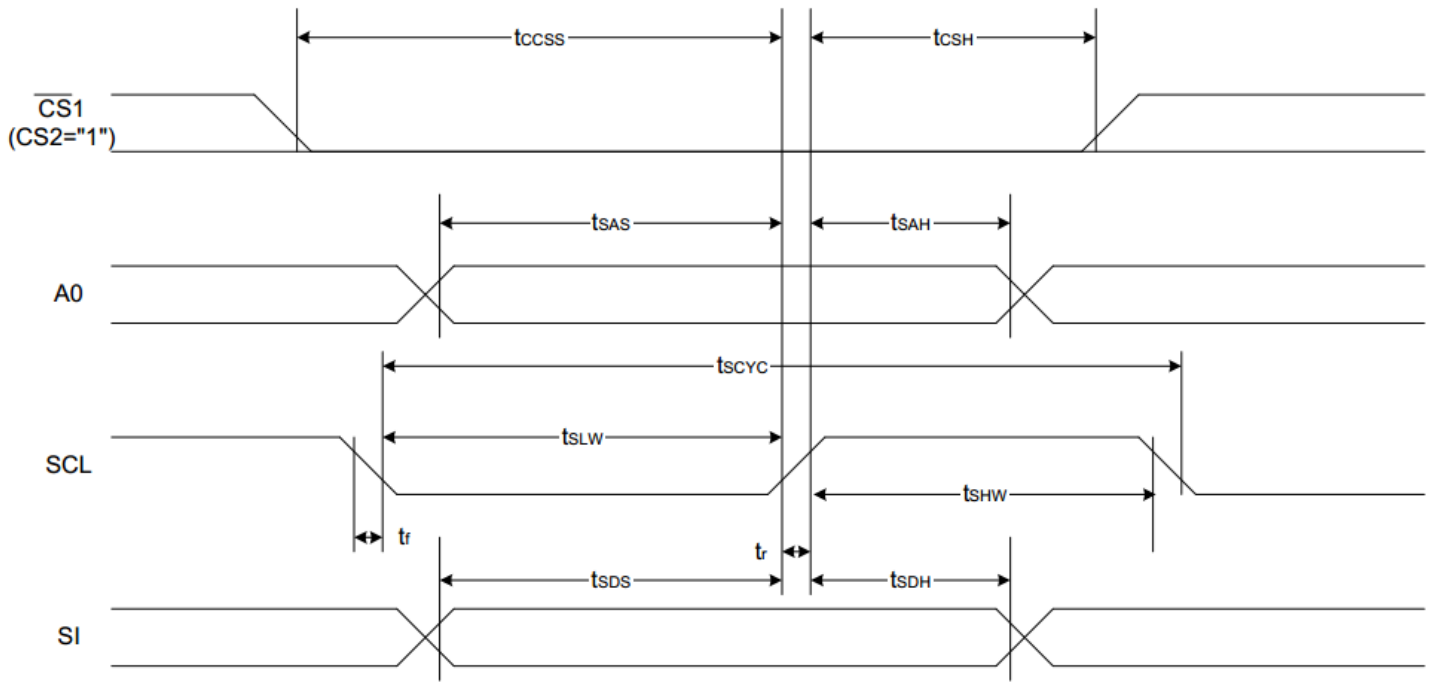

($V_{\text{DD}} = 3.3\text{V}$, $T_{\text{a}} = -30$ to 85°C)

Item	Signal	Symbol	Condition	Rating		Units
				Min.	Max.	
4-line SPI Clock Period	SCL	T_{scyc}		50	—	ns
SCL "H" pulse width		T_{shw}		25	—	
SCL "L" pulse width		T_{SLW}		25	—	
Address setup time	A0	T_{SAS}		20	—	
Address hold time		T_{sah}		10	—	
Data setup time	SI	T_{sds}		20	—	
Data hold time		T_{SDH}		10	—	
CS-SCL time	CS	T_{css}		20	—	
CS-SCL time		T_{csh}		40	—	

Example Initialization Program

```
'-----  
Sub Init  
Reset P3.7          'set Read/write to '0' for write  
Reset P3.0          'RS  
Set P3.1            'reset  
Reset P3.4 'E  
'Set P3.3  
'Reset P3.3  
Waitms 2  
'Set P3.3  
Waitms 20  
A = &HA2            '1/9 BIAS  
Call Writecom  
A = &HA0            'ADC SELECT , NORMAL  
Call Writecom  
A = &HC8            'COM OUTPUT REVERSE  
Call Writecom  
A = &HA4            'DISPLAY ALL POINTS NORMAL  
Call Writecom  
A = &H40            'DISPLAY START LINE SET  
Call Writecom  
A = &H25            'INTERNAL RESISTOR RATIO  
Call Writecom  
A = &H81            'ELECTRONIC VOLUME MODE SET  
Call Writecom  
A = &H10            'ELECTRONIC VOLUME  
Call Writecom  
A = &H2F            'POWER CONTROLLER SET  
Call Writecom  
A = &HAF            'DISPLAY ON  
Call Writecom  
End Sub
```

```
'-----  
Sub Writecom  
Reset P3.0          'A0 low  
Reset P3.7          'R/W low  
Set P3.6            'CS2  
Set P3.4            'E  
P1 = A  
Reset P3.4  
Reset P3.6  
Reset P3.7  
End Sub
```

```
Sub Writedata  
Set P3.0            'A0 high  
Reset P3.7          'R/W low  
Set P3.6            'CS2  
Set P3.4            'E  
P1 = A  
Reset P3.4  
Reset P3.6  
Reset P3.7  
End Sub
```

```
'-----
```

Quality Information

Test Item	Content of Test	Test Condition	Note
High Temperature storage	Endurance test applying the high storage temperature for a long time.	+80°C , 48hrs	2
Low Temperature storage	Endurance test applying the low storage temperature for a long time.	-30°C , 48hrs	1,2
High Temperature Operation	Endurance test applying the electric stress (voltage & current) and the high thermal stress for a long time.	+70°C 48hrs	2
Low Temperature Operation	Endurance test applying the electric stress (voltage & current) and the low thermal stress for a long time.	-20°C , 48hrs	1,2
High Temperature / Humidity Operation	Endurance test applying the electric stress (voltage & current) and the high thermal with high humidity stress for a long time.	+40°C , 90% RH , 48hrs	1,2
Thermal Shock resistance	Endurance test applying the electric stress (voltage & current) during a cycle of low and high thermal stress.	-0°C,30min -> 25°C,5min -> 50°C,30min = 1 cycle 10 cycles	
Vibration test	Endurance test applying vibration to simulate transportation and use.	10-55Hz , 15mm amplitude. 60 sec in each of 3 directions X,Y,Z For 15 minutes	3
Static electricity test	Endurance test applying electric static discharge.	VS=800V, RS=1.5kΩ, CS=100pF One time	

Note 1: No condensation to be observed.

Note 2: Conducted after 4 hours of storage at 25°C, 0%RH.

Note 3: Test performed on product itself, not inside a container.

Precautions for using LCDs/LCMs

See Precautions at www.newhavendisplay.com/specs/precautions.pdf

Warranty Information and Terms & Conditions

http://www.newhavendisplay.com/index.php?main_page=terms



Компания «ЭлектроПласт» предлагает заключение долгосрочных отношений при поставках импортных электронных компонентов на взаимовыгодных условиях!

Наши преимущества:

- Оперативные поставки широкого спектра электронных компонентов отечественного и импортного производства напрямую от производителей и с крупнейших мировых складов;
- Поставка более 17-ти миллионов наименований электронных компонентов;
- Поставка сложных, дефицитных, либо снятых с производства позиций;
- Оперативные сроки поставки под заказ (от 5 рабочих дней);
- Экспресс доставка в любую точку России;
- Техническая поддержка проекта, помощь в подборе аналогов, поставка прототипов;
- Система менеджмента качества сертифицирована по Международному стандарту ISO 9001;
- Лицензия ФСБ на осуществление работ с использованием сведений, составляющих государственную тайну;
- Поставка специализированных компонентов (Xilinx, Altera, Analog Devices, Intersil, Interpoint, Microsemi, Aeroflex, Peregrine, Syfer, Eurofarad, Texas Instrument, Miteq, Cobham, E2V, MA-COM, Hittite, Mini-Circuits, General Dynamics и др.);

Помимо этого, одним из направлений компании «ЭлектроПласт» является направление «Источники питания». Мы предлагаем Вам помощь Конструкторского отдела:

- Подбор оптимального решения, техническое обоснование при выборе компонента;
- Подбор аналогов;
- Консультации по применению компонента;
- Поставка образцов и прототипов;
- Техническая поддержка проекта;
- Защита от снятия компонента с производства.



Как с нами связаться

Телефон: 8 (812) 309 58 32 (многоканальный)

Факс: 8 (812) 320-02-42

Электронная почта: org@eplast1.ru

Адрес: 198099, г. Санкт-Петербург, ул. Калинина, дом 2, корпус 4, литера А.