

HCPL-0708

High Speed CMOS Optocoupler



Data Sheet



Lead (Pb) Free
RoHS 6 fully compliant

RoHS 6 fully compliant options available;
-xxxE denotes a lead-free product

Description

Available in SO-8 package, the HCPL-0708 optocoupler utilizes the latest CMOS IC technology to achieve outstanding performance with very low power consumption. Basic building blocks of the HCPL-0708 are a high speed LED and a CMOS detector IC. The detector incorporates an integrated photodiode, a high-speed transimpedance amplifier, and a voltage comparator with an output driver.

Functional Diagram

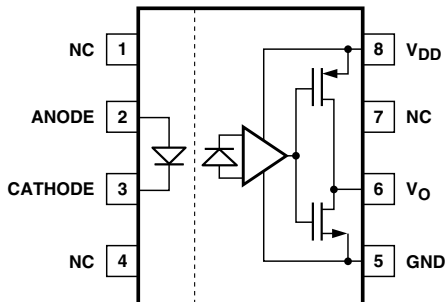

TRUTH TABLE

LED	VO, OUTPUT
OFF	H
ON	L

*A 0.1 μ F bypass capacitor must be connected between pins 5 and 8.

Features

- +5 V CMOS compatibility
- 15 ns typical pulse width distortion
- 30 ns max. pulse width distortion
- 40 ns max. propagation delay skew
- High speed: 15 MBd
- 60 ns max. propagation delay
- 10 kV/ μ s minimum common mode rejection
- -40 to 100°C temperature range
- Safety and regulatory approvals pending
 - UL recognized
 - 3750 V rms for 1 min. per UL 1577 for HCPL-0708
 - CSA component acceptance Notice #5
 - IEC/EN/DIN EN 60747-5-2 approved for HCPL-0708 Option 060

Applications

- Scan drive in PDP
- Digital field bus isolation: DeviceNet, SDS, Profibus
- Multiplexed data transmission
- Computer peripheral interface
- Microprocessor system interface

CAUTION: It is advised that normal static precautions be taken in handling and assembly of this component to prevent damage and/or degradation which may be induced by ESD.

Ordering Information

HCPL-0708 is UL Recognized with 3750 Vrms for 1 minute per UL1577.

Part Number	Option		Package	Surface Mount	Gull Wing	Tape & Reel	UL 5000 Vrms/ 1 Minute rating	IEC/EN/DIN EN 60747-5-2	Quantity
	RoHS Compliant	non RoHS Compliant							
HCPL-0708	-000E	no option	SO-8	X					100 per tube
	-500E	#500		X		X			1500 per reel
	-560E	-		X		X		X	1500 per reel

To order, choose a part number from the part number column and combine with the desired option from the option column to form an order entry.

Example 1:

HCPL-0708-500E to order product of Small Outline SO-8 package in Tape and Reel packaging and RoHS compliant.

Example 2:

HCPL-0708 to order product of Small Outline SO-8 package in Tube packaging and non RoHS compliant.

Option datasheets are available. Contact your Avago sales representative or authorized distributor for information.

Remarks: The notation '#XXX' is used for existing products, while (new) products launched since July 15, 2001 and RoHS compliant will use '-XXXE'.

Package Outline Drawing

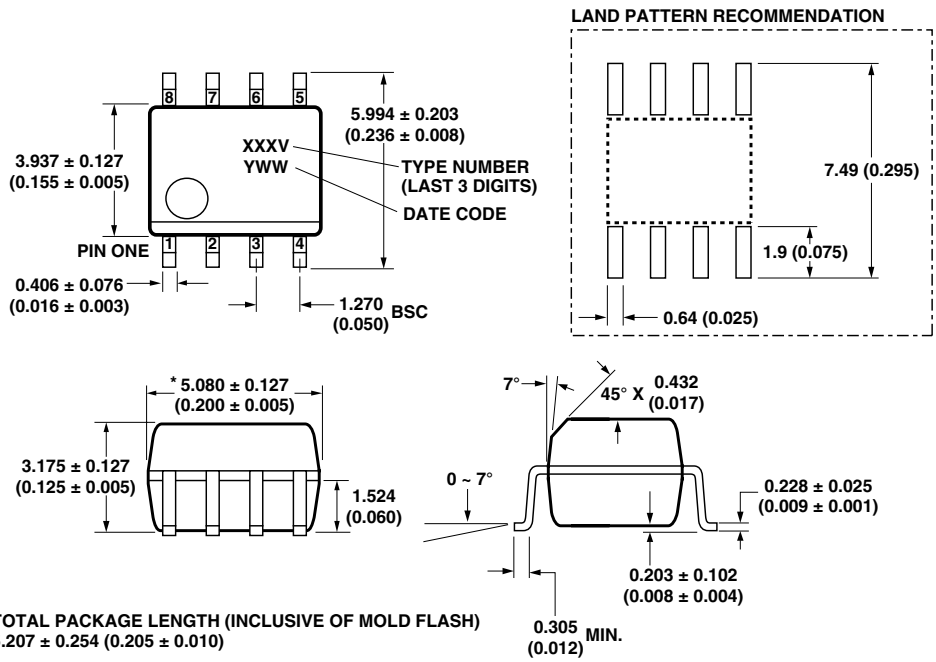

DIMENSIONS IN MILLIMETERS (INCHES).
LEAD COPLANARITY = 0.10 mm (0.004 INCHES) MAX.

OPTION NUMBER 500 NOT MARKED.

NOTE: FLOATING LEAD PROTRUSION IS 0.15 mm (6 mils) MAX.

Solder Reflow Thermal Profile

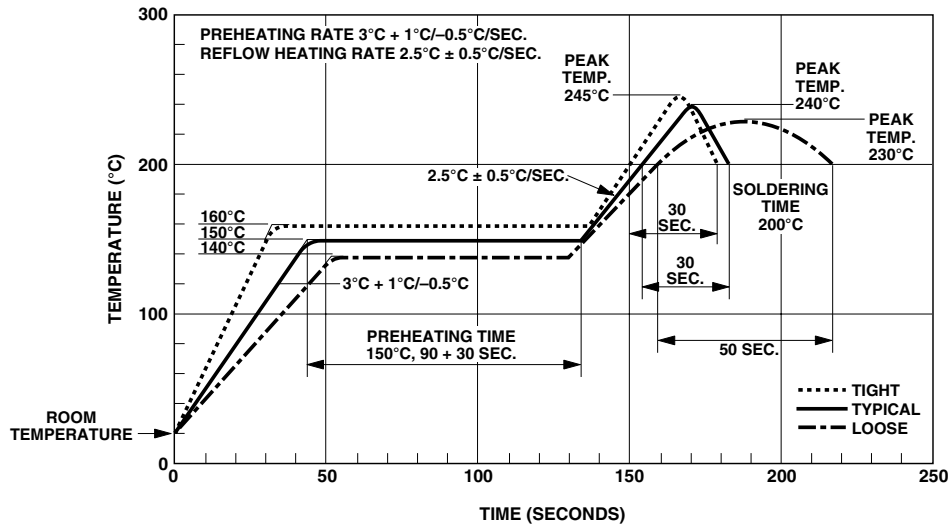

Note: Non-halide flux should be used.

Recommended Pb-Free IR Profile

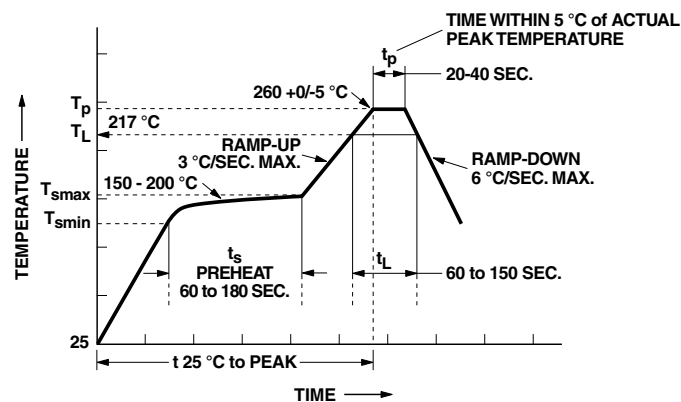

NOTES:
 THE TIME FROM 25°C TO PEAK TEMPERATURE = 8 MINUTES MAX.
 $T_{smax} = 200^{\circ}\text{C}$, $T_{smin} = 150^{\circ}\text{C}$

Note: Non-halide flux should be used.

Regulatory Information

The HCPL-0708 has been approved by the following organizations:

UL

Recognized under UL 1577, component recognition program, File E55361.

CSA

Approved under CSA Component Acceptance Notice #5, File CA88324.

IEC/EN/DIN EN 60747-5-2

Approved under:

IEC 60747-5-2:1997 + A1:2002

EN 60747-5-2:2001 + A1:2002

DIN EN 60747-5-2 (VDE 0884Teil 2):2003-01 (Option 060 only)

Insulation and Safety Related Specifications

Parameter	Symbol	Value	Units	Conditions
Minimum External Air Gap (Clearance)	L(I01)	4.9	mm	Measured from input terminals to output terminals, shortest distance through air.
Minimum External Tracking (Creepage)	L(I02)	4.8	mm	Measured from input terminals to output terminals, shortest distance path along body.
Minimum Internal Plastic Gap (Internal Clearance)		0.08	mm	Insulation thickness between emitter and detector; also known as distance through insulation.
Tracking Resistance (Comparative Tracking Index)	CTI	≥175	Volts	DIN IEC 112/VDE 0303 Part 1
Isolation Group		IIIa		Material Group (DIN VDE 0110, 1/89, Table 1)

All Avago data sheets report the creepage and clearance inherent to the optocoupler component itself. These dimensions are needed as a starting point for the equipment designer when determining the circuit insulation requirements. However, once mounted on a printed circuit board, minimum creepage and clearance requirements must be met as specified for individual equipment standards. For creepage, the shortest distance path along

the surface of a printed circuit board between the solder fillets of the input and output leads must be considered. There are recommended techniques such as grooves and ribs which may be used on a printed circuit board to achieve desired creepage and clearances. Creepage and clearance distances will also change depending on factors such as pollution degree and insulation level.

IEC/EN/DIN EN 60747-5-2 Insulation Related Characteristics (Option 060)

Description	Symbol	HCPL-0708 Option 060	Units
Installation classification per DIN VDE 0110/1.89, Table 1 for rated mains voltage ≤ 150 V rms for rated mains voltage ≤ 300 V rms for rated mains voltage ≤ 450 V rms		I-IV I-III	
Climatic Classification		55/85/21	
Pollution Degree (DIN VDE 0110/1.89)		2	
Maximum Working Insulation Voltage	V_{IORM}	560	V peak
Input to Output Test Voltage, Method b† $V_{IORM} \times 1.875 = V_{PR}$, 100% Production Test with $t_m = 1$ sec, Partial Discharge < 5 pC	V_{PR}	1050	V peak
Input to Output Test Voltage, Method a† $V_{IORM} \times 1.5 = V_{PR}$, Type and Sample Test, $t_m = 60$ sec, Partial Discharge < 5 pC	V_{PR}	840	V peak
Highest Allowable Overvoltage† (Transient Overvoltage, $t_{ini} = 10$ sec)	V_{IOTM}	4000	V peak
Safety Limiting Values (Maximum values allowed in the event of a failure, also see Thermal Derating curve, Figure 11.)			
Case Temperature	T_S	150	°C
Input Current	$I_{S,INPUT}$	150	mA
Output Power	$P_{S,OUTPUT}$	600	mW
Insulation Resistance at T_S , $V_{10} = 500$ V	R_{IO}	$\geq 10^9$	Ω

†Refer to the front of the optocoupler section of the Isolation and Control Component Designer's Catalog, under Product Safety Regulations section IEC/EN/DIN EN 60747-5-2, for a detailed description.

Absolute Maximum Ratings

Parameter	Symbol	Min.	Max.	Units	Figure
Storage Temperature	T_S	-55	125	°C	
Ambient Operating Temperature ^[1]	T_A	-40	+100	°C	
Supply Voltages	V_{DD}	0	6	Volts	
Output Voltage	V_O	-0.5	$V_{DD2} + 0.5$	Volts	
Average Output Current	I_O		2	mA	
Average Forward Input Current	I_F		20	mA	
Lead Solder Temperature		260°C for 10 sec., 1.6 mm below seating plane			
Solder Reflow Temperature Profile		See Solder Reflow Temperature Profile Section			

Recommended Operating Conditions

Parameter	Symbol	Min.	Max.	Units	Figure
Ambient Operating Temperature	T_A	-40	+100	°C	
Supply Voltages	V_{DD}	4.5	5.5	V	
Input Current (ON)	I_F	10	16	mA	1, 2

Electrical Specifications

Over recommended temperature ($T_A = -40^{\circ}\text{C}$ to $+100^{\circ}\text{C}$) and $4.5\text{ V} \leq V_{DD} \leq 5.5\text{ V}$.

All typical specifications are at $T_A = 25^{\circ}\text{C}$, $V_{DD} = +5\text{ V}$.

Parameter	Symbol	Min.	Typ.	Max.	Units	Test Conditions	Fig.	Notes
Input Forward Voltage	V_F	1.3	1.5	1.8	V	$I_F = 12\text{ mA}$	1	
Input Reverse Breakdown Voltage	BV_R	5			V	$I_R = 10\text{ }\mu\text{A}$		
Logic High Output Voltage	V_{OH}	4.0	4.8		V	$I_F = 0, I_O = -20\text{ }\mu\text{A}$		
Logic Low Output Voltage	V_{OL}		0.01	0.1	V	$I_F = 12\text{ mA}, I_O = 20\text{ }\mu\text{A}$		
Input Threshold Current	I_{TH}			8.2	mA	$I_{OL} = 20\text{ }\mu\text{A}$	2	
Logic Low Output Supply Current	I_{DDL}		6.0	14.0	mA	$I_F = 12\text{ mA}$	4	
Logic High Output Supply Current	I_{DDH}		4.5	11.0	mA	$I_F = 0$	3	

Switching Specifications

Over recommended temperature ($T_A = -40^{\circ}\text{C}$ to $+100^{\circ}\text{C}$) and $4.5\text{ V} \leq V_{DD} \leq 5.5\text{ V}$.

All typical specifications are at $T_A = 25^{\circ}\text{C}$, $V_{DD} = +5\text{ V}$.

Parameter	Symbol	Min.	Typ.	Max.	Units	Test Conditions	Fig.	Notes
Propagation Delay Time to Logic Low Output	t_{PHL}	20	35	60	ns	$I_F = 12\text{ mA}, C_L = 15\text{ pF}$ CMOS Signal Levels	5	1
Propagation Delay Time to Logic High Output	t_{PLH}	13	21	60	ns	$I_F = 12\text{ mA}, C_L = 15\text{ pF}$ CMOS Signal Levels	5	1
Pulse Width	PW	100			ns			
Pulse Width Distortion	PWD	0	14	30	ns	$I_F = 12\text{ mA}, C_L = 15\text{ pF}$ CMOS Signal Levels	2	2
Propagation Delay Skew	t_{PSK}			40	ns	$I_F = 12\text{ mA}, C_L = 15\text{ pF}$ CMOS Signal Levels	3	3
Output Rise Time (10 - 90%)	t_R		20		ns	$I_F = 12\text{ mA}, C_L = 15\text{ pF}$ CMOS Signal Levels		
Output Fall Time (90 - 10%)	t_F		25		ns	$I_F = 12\text{ mA}, C_L = 15\text{ pF}$ CMOS Signal Levels		
Common Mode Transient Immunity at Logic High Output	$ CM_H $	10	15		kV/ μs	$V_{CM} = 1000\text{ V}, T_A = 25^{\circ}\text{C},$ $I_F = 0\text{ mA}$	4	4
Common Mode Transient Immunity at Logic Low Output	$ CM_L $	10	15		kV/ μs	$V_{CM} = 1000\text{ V}, T_A = 25^{\circ}\text{C},$ $I_F = 12\text{ mA}$	5	5

Package Characteristics

All Typicals at $T_A = 25^\circ\text{C}$.

Parameter	Symbol	Min.	Typ.	Max.	Units	Test Conditions
Input-Output Insulation	I_{I-O}			1	μA	45% RH, $t = 5 \text{ s}$ $V_{I-O} = 3 \text{ kV dc}$, $T_A = 25^\circ\text{C}$
Input-Output Momentary Withstand Voltage	V_{ISO}	3750			V_{rms}	$\text{RH} \leq 50\%$, $t = 1 \text{ min.}$, $T_A = 25^\circ\text{C}$
Input-Output Resistance	R_{I-O}		10^{12}		Ω	$V_{I-O} = 500 \text{ V dc}$
Input-Output Capacitance	C_{I-O}		0.6		pF	$f = 1 \text{ MHz}$, $T_A = 25^\circ\text{C}$

Notes:

1. t_{PHL} propagation delay is measured from the 50% level on the rising edge of the input pulse to the 2.5 V level of the falling edge of the V_O signal. t_{PLH} propagation delay is measured from the 50% level on the falling edge of the input pulse to the 2.5 V level of the rising edge of the V_O signal.
2. PWD is defined as $|t_{\text{PHL}} - t_{\text{PLH}}|$.
3. t_{PSK} is equal to the magnitude of the worst case difference in t_{PHL} and/or t_{PLH} that will be seen between units at any given temperature within the recommended operating conditions.
4. CM_H is the maximum tolerable rate of rise of the common mode voltage to assure that the output will remain in a high logic state.
5. CM_L is the maximum tolerable rate of fall of the common mode voltage to assure that the output will remain in a low logic state.

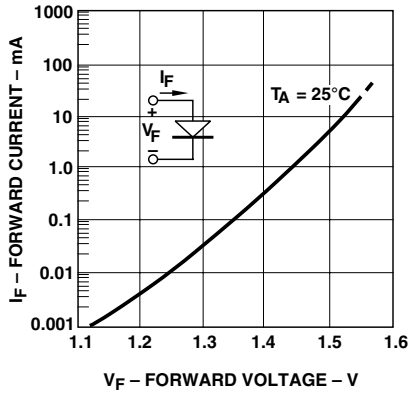

Figure 1. Typical input diode forward characteristic.

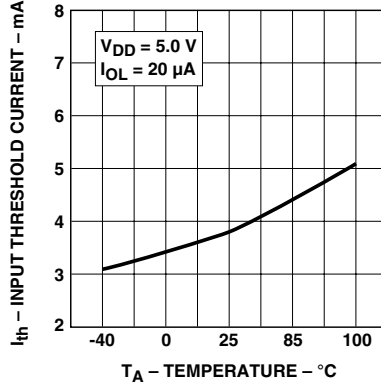

Figure 2. Typical input threshold current vs. temperature.

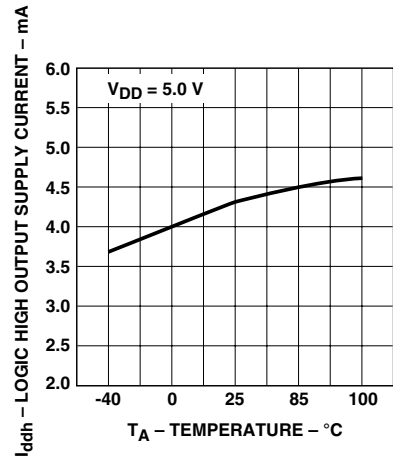

Figure 3. Typical logic high O/P supply current vs. temperature.

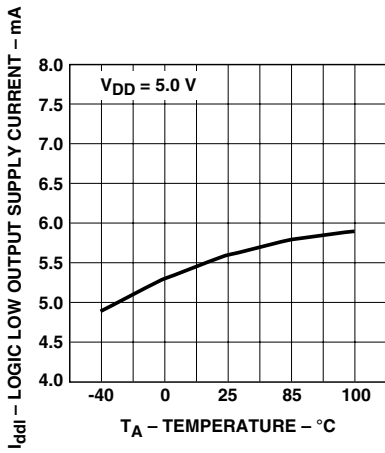

Figure 4. Typical logic low O/P supply current vs. temperature.

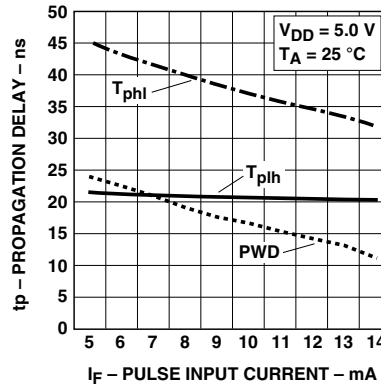

Figure 5. Typical switching speed vs. pulse input current.

Application Information

Bypassing and PC Board Layout

The HCPL-0708 optocoupler is extremely easy to use. No external interface circuitry is required because the HCPL-0708 uses high-speed CMOS IC technology allowing CMOS logic to be connected directly to the inputs and outputs.

As shown in Figure 6, the only external component required for proper operation is the bypass capacitor. Capacitor values should be between 0.01 μF and 0.1 μF . For each capacitor, the total lead length between both ends of the capacitor and the power-supply pins should not exceed 20 mm. Figure 7 illustrates the recommended printed circuit board layout for the HPCL-0708.

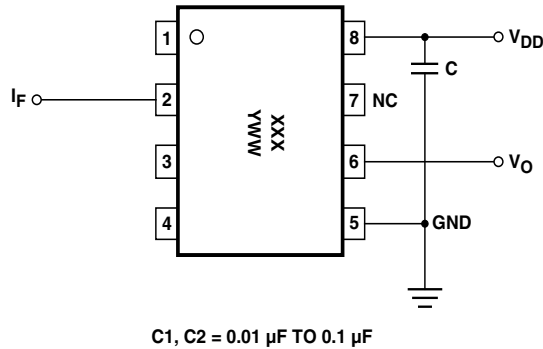

Figure 6. Recommended printed circuit board layout.

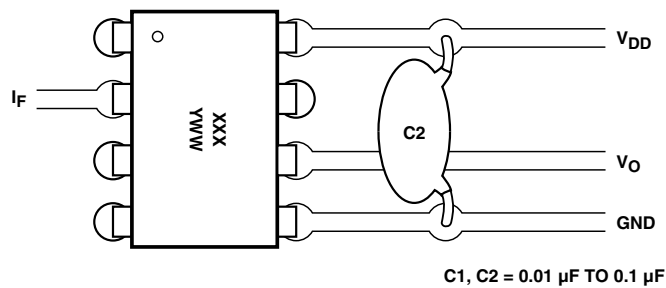

Figure 7. Recommended printed circuit board layout.

Propagation Delay, Pulse-Width Distortion and Propagation Delay Skew

Propagation Delay is a figure of merit which describes how quickly a logic signal propagates through a system. The propagation delay from low to high (t_{PLH}) is the amount of time required for an input signal to propagate to the output, causing the output to change from low

to high. Similarly, the propagation delay from high to low (t_{PHL}) is the amount of time required for the input signal to propagate to the output, causing the output to change from high to low. See Figure 8.

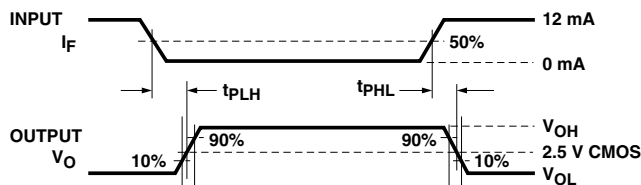

Figure 8.

Pulse-width distortion (PWD) is the difference between t_{PHL} and t_{PLH} and often determines the maximum data rate capability of a transmission system. PWD can be expressed in percent by dividing the PWD (in ns) by the minimum pulse width (in ns) being transmitted. Typically, PWD on the order of 20 - 30% of the minimum pulse width is tolerable; the exact figure depends on the particular application.

Propagation delay skew, t_{PSK} , is an important parameter to consider in parallel data applications where synchronization of signals on parallel data lines is a concern. If the parallel data is being sent through a group of optocouplers, differences in propagation delays will cause the data to arrive at the outputs of the optocouplers at different times. If this difference in propagation delay is large enough it will determine the maximum rate at which parallel data can be sent through the optocouplers.

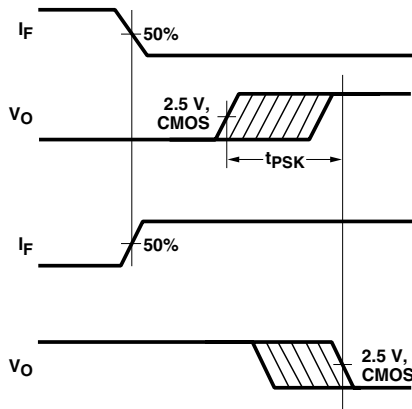

Figure 9. Propagation delay skew waveform.

Propagation delay skew represents the uncertainty of where an edge might be after being sent through an optocoupler. Figure 10 shows that there will be uncertainty in both the data and clock lines. It is important that these two areas of uncertainty not overlap, otherwise the clock signal might arrive before all of the data outputs have settled, or some of the data outputs may start to change before the clock signal has arrived. From these considerations, the absolute minimum pulse width that can be sent

through optocouplers in a parallel application is twice t_{PSK} . A cautious design should use a slightly longer pulse width to ensure that any additional uncertainty in the rest of the circuit does not cause a problem.

The HCPL-0708 optocouplers offer the advantage of guaranteed specifications for propagation delays, pulse-width distortion, and propagation delay skew over the recommended temperature and power supply ranges.

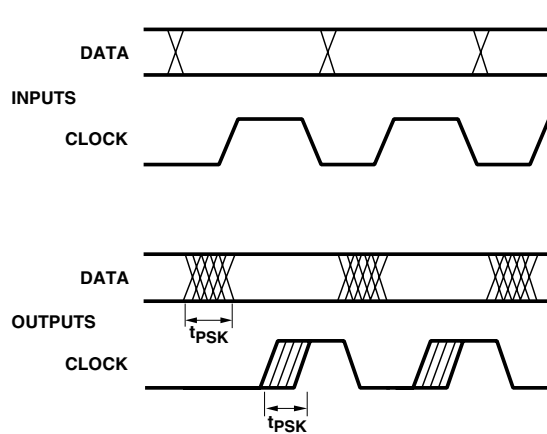

Figure 10. Parallel data transmission example.

through optocouplers in a parallel application is twice t_{PSK} . A cautious design should use a slightly longer pulse width to ensure that any additional uncertainty in the rest of the circuit does not cause a problem.

The HCPL-0708 optocouplers offer the advantage of guaranteed specifications for propagation delays, pulse-width distortion, and propagation delay skew over the recommended temperature and power supply ranges.

For product information and a complete list of distributors, please go to our web site: www.avagotech.com

Avago, Avago Technologies, and the A logo are trademarks of Avago Technologies, Limited in the United States and other countries. Data subject to change. Copyright © 2007 Avago Technologies Limited. All rights reserved. Obsoletes AV02-0877EN

AV02-0877EN January 8, 2008





Компания «ЭлектроПласт» предлагает заключение долгосрочных отношений при поставках импортных электронных компонентов на взаимовыгодных условиях!

Наши преимущества:

- Оперативные поставки широкого спектра электронных компонентов отечественного и импортного производства напрямую от производителей и с крупнейших мировых складов;
- Поставка более 17-ти миллионов наименований электронных компонентов;
- Поставка сложных, дефицитных, либо снятых с производства позиций;
- Оперативные сроки поставки под заказ (от 5 рабочих дней);
- Экспресс доставка в любую точку России;
- Техническая поддержка проекта, помощь в подборе аналогов, поставка прототипов;
- Система менеджмента качества сертифицирована по Международному стандарту ISO 9001;
- Лицензия ФСБ на осуществление работ с использованием сведений, составляющих государственную тайну;
- Поставка специализированных компонентов (Xilinx, Altera, Analog Devices, Intersil, Interpoint, Microsemi, Aeroflex, Peregrine, Syfer, Eurofarad, Texas Instrument, Miteq, Cobham, E2V, MA-COM, Hittite, Mini-Circuits, General Dynamics и др.);

Помимо этого, одним из направлений компании «ЭлектроПласт» является направление «Источники питания». Мы предлагаем Вам помощь Конструкторского отдела:

- Подбор оптимального решения, техническое обоснование при выборе компонента;
- Подбор аналогов;
- Консультации по применению компонента;
- Поставка образцов и прототипов;
- Техническая поддержка проекта;
- Защита от снятия компонента с производства.



Как с нами связаться

Телефон: 8 (812) 309 58 32 (многоканальный)

Факс: 8 (812) 320-02-42

Электронная почта: org@eplast1.ru

Адрес: 198099, г. Санкт-Петербург, ул. Калинина, дом 2, корпус 4, литера А.