

Revision Control Record

Rev.	Description of Change	ECN No.	Date
D	NOTES & VIEW	03189	5/29/03
E	CAP COLOR TO RED	03257	7/15/03
F	DIMENSIONS & VIEW	03733	12/23/03

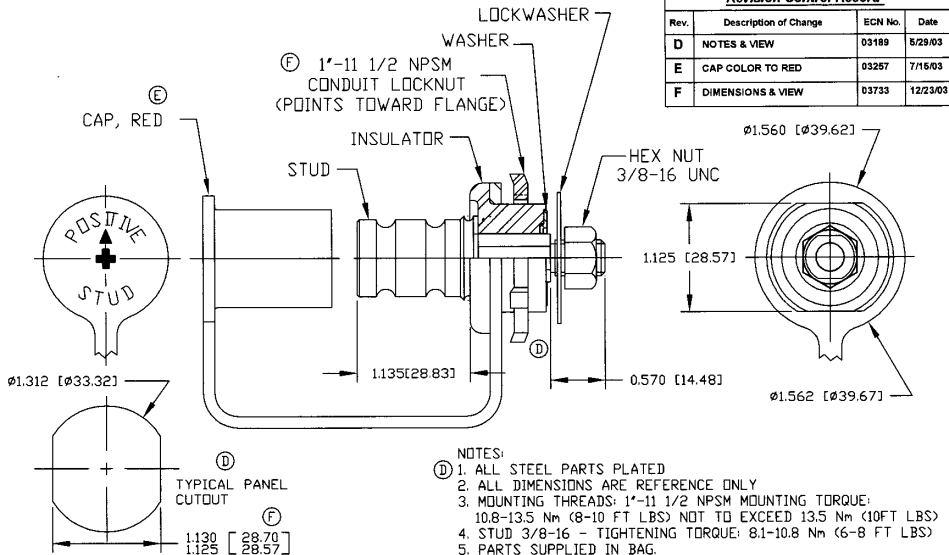

- NOTES:
1. ALL STEEL PARTS PLATED
 2. ALL DIMENSIONS ARE REFERENCE ONLY
 3. MOUNTING THREADS: 1"-11 1/2 NPSM MOUNTING TORQUE: 10.8-13.5 Nm (8-10 FT LBS) NOT TO EXCEED 13.5 Nm (10FT LBS)
 4. STUD 3/8-16 - TIGHTENING TORQUE: 8.1-10.8 Nm (6-8 FT LBS)
 5. PARTS SUPPLIED IN BAG.

Tolerances. Unless otherwise specifically noted, the following are default tolerances:

- 2-place Decimal Dimensions $\pm .02^{\circ}$
- 3-place Decimal Dimensions $\pm .005^{\circ}$
- Angular Dimensions ± 1.0 Deg.
- Metric: Refer to equivalent English Dimension Tolerance
- NOTE: All tolerances are Non-Cumulative. <<<

Dimensional Limits. All dimensions are expressed in inches except those shown in brackets (xxx) are expressed in millimeters

*RFP - or an As-Built - is Non-Toleranced Reference Dimensions, shown for identification purposes only.

PROPRIETARY INFORMATION. This Engineering Drawing, and the information contained herein, is proprietary to Cole Hersee Company and may not be disclosed, re-produced, or in any other way transmitted or communicated to any other party without the express written consent of an authorized representative of Cole Hersee Company.

DESIGN CONTROL. It is the responsibility of the individual using/ referring this drawing to assure that the noted design revision level agrees with the revision level of the Controlled Document (Master Drawing). This is a NON-CONTROLLED DOCUMENT unless otherwise specifically noted.

DO NOT SCALE - Dimensional variation may occur during printing/ reproduction.

Special Characteristics...

- Critical Characteristic, relating to Safety and/or Regulatory Compliance
- Significant Characteristic relating to Process Control (SPC)
- Key Characteristics relating to Form - Fit - Function as defined by Cole Hersee Company and/or the Customer

(Note that the identification of any Characteristics as being "Special" does not alter the requirement that ALL specified dimensions & tolerances must be met.)



Cole Hersee Co.

20 Old Colony Ave., South Boston, MA, 02127
Phn 617-268-2100 Web: www.coleshersee.com

Description:

STUD, JUMPER, POS

Drawing/
Part No.:

46210-02

Current Rev.

F

Used On
or Ref:

Scale: **1:1**

Drawn By: **DPS**

Date Drawn: **8/07/80**

Responsible Engineer: **SAM**

Pg. 1 of 1

Revision Control Record

Rev.	Description of Change	ECN No.	Date
C	NOTES & VIEW	03189	5/29/03
D	DIMENSIONS & VIEW	3733	12/23/03

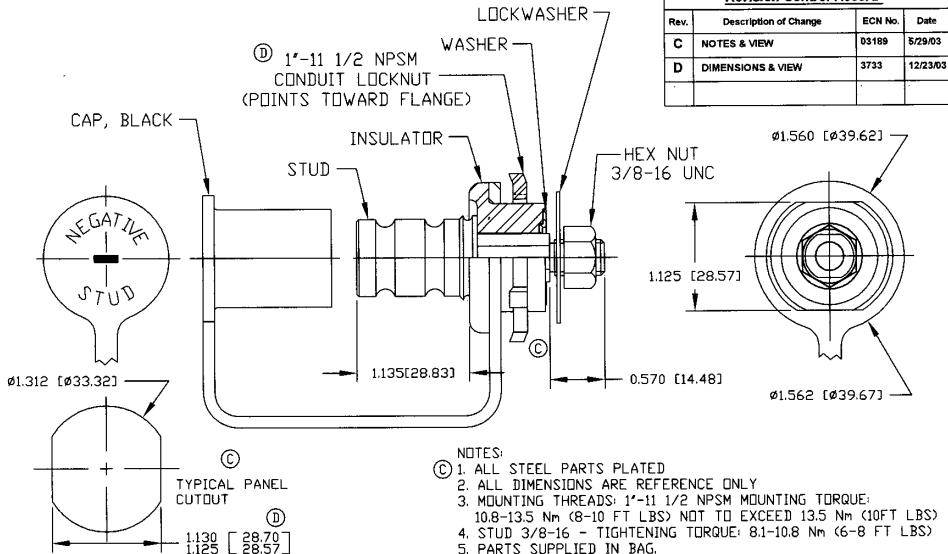

Tolerances. Unless otherwise specifically noted, the following are default tolerances:
 * 2-place Decimal Dimensions $\pm .02$
 * 3-place Decimal Dimensions $\pm .005$
 * Angular Dimensions ± 1.0 Deg
 * Metric: Refer to equivalent English Dimension Tolerance
 >>> NOTE: All tolerances are Non-Cumulative. <<<

Dimensional Units. All dimensions are expressed in inches except those shown in brackets (xx) are expressed in millimeters

RRP or an Abbreviated CD = Non-Tolerance Reference Dimension, shown for identification purposes only.

PROPRIETARY INFORMATION. This Engineering Drawing, and the information contained herein, is proprietary to Cole Hersee Company and may not be disclosed, re-produced, or in any other way transferred or communicated to any other party without the express written consent of an authorized representative of Cole Hersee Company.

DESIGN CONTROL. It is the responsibility of the individual using / referring this drawing to ensure that the noted design revision level agrees with the revision level of the Controlled Document (Master Drawing). This is a NON-CONTROLLED DOCUMENT unless otherwise specifically noted.

DO NOT SCALE - Dimensional variation may occur during printing / reproduction.

Special Characteristics.

- Critical Characteristic, relating to Safety and/or Regulatory Compliance
 - Significant Characteristics relating to Process Control (SPC)
 - Key Characteristic relating to Form - Fit - Function as defined by Cole Hersee Company and/or the Customer
- (Note that the Identification of any Characteristics as being "Special" does not alter the requirement that ALL specified dimensions & tolerances must be met.)



Cole Hersee Co.

20 Old Colony Ave., South Boston, MA, 02127
 Phone 617-268-2100 Web: www.colehersee.com

Description: **JUMPER STUD, NEG.**

Drawing / Part No.: **46210-03**

Current Rev. **D**

Used On / of Ref.: Scale: **1:1**

Drawn: **RG**

Date: **8/07/80**

Responsible Engineer: **SAM**

Pg. 1 of 1

Revision Control Record			
Rev.	Description of Change	ECN No.	Date
H	NOTE 5	00685	9/13/00
J	NOTES & VIEW	03189	5/30/03
K	DIMENSIONS & VIEW	12/23/03	12/23/03
L	ADDED BLACK	12085	03/16/12

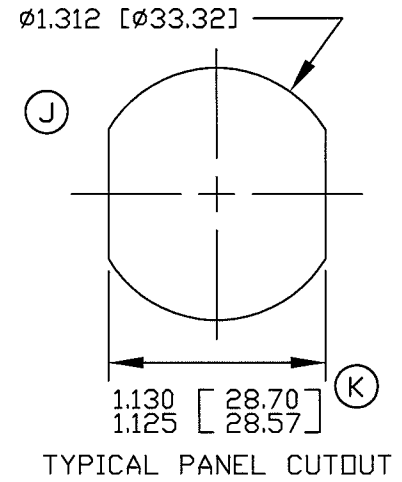
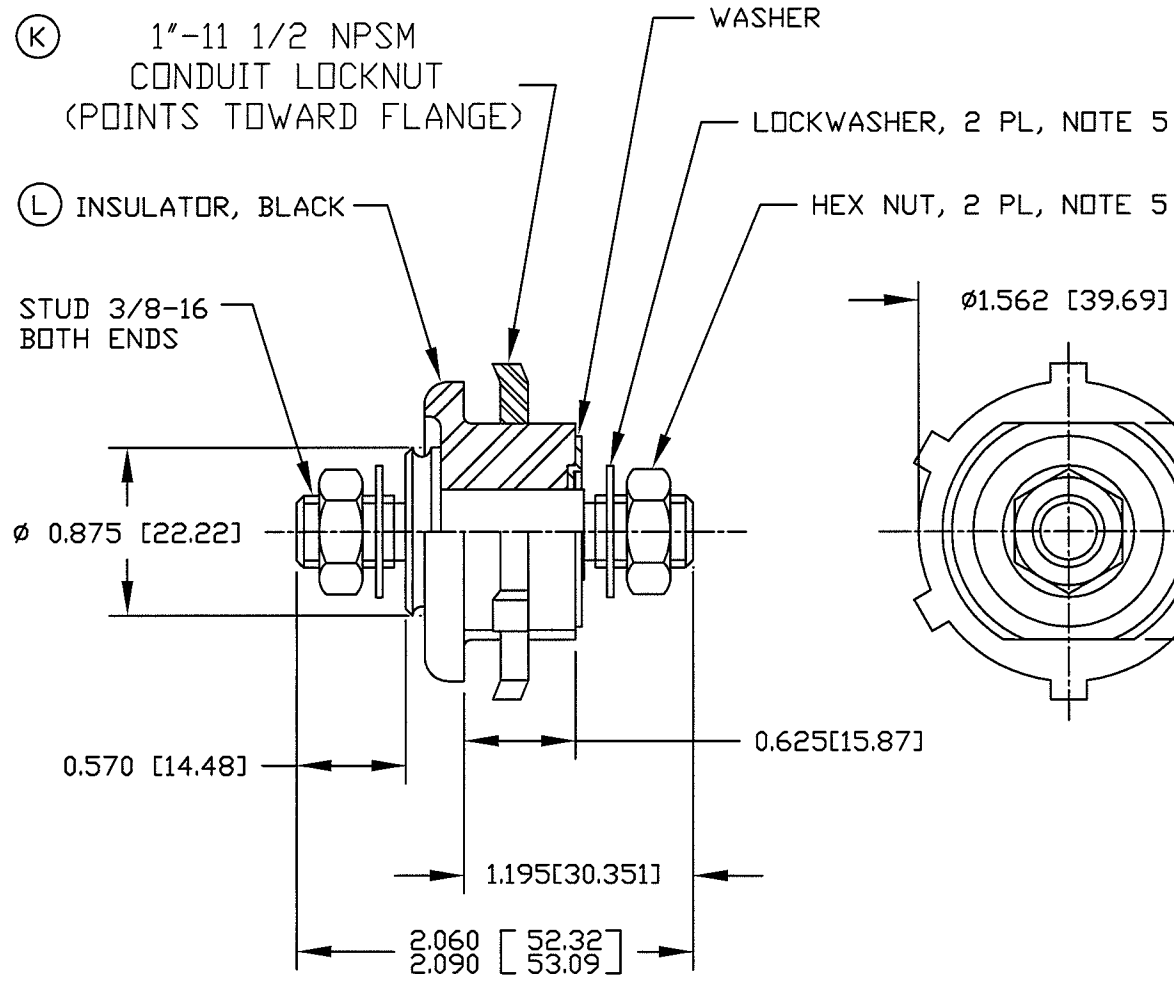

- J** NOTES:
1. ALL STEEL PARTS PLATED
 2. ALL DIMENSIONS ARE REFERENCE ONLY
 3. MOUNTING THREADS 1"-11 1/2 NPSM- MOUNTING TORQUE 10.8-13.5 Nm (8-10 FT LBS) NOT TO EXCEED 13.5 Nm (10 FT LBS)
 4. STUD 3/8-16 TIGHTENING TORQUE 8.1-10.8 Nm (6-8 FT LBS)
 5. PARTS SUPPLIED IN BAG

Tolerances Unless otherwise specifically noted, the following are default tolerances:
 * 2-place Decimal Dimensions +/- .02"
 * 3-place Decimal Dimensions +/- .005"
 * Angular Dimensions +/- 1.0 Deg.
 * Metric: Refer to equivalent English Dimension Tolerance
 >>> NOTE: All tolerances are Non-Cumulative. <<<

Dimensional Units All dimensions are expressed in inches except those shown in brackets (xxx) are expressed in millimeters

"REF." or an Asterisk (*) = Non-Toleranced Reference Dimension, shown for clarification purposes only.

PROPRIETARY INFORMATION This Engineering Drawing, and the information contained herein, is proprietary to Cole Hersee Company and may not be disclosed, re-produced, or in any other way transferred or communicated to any other party without the express written consent of an authorized representative of Cole Hersee Company.

DESIGN CONTROL It is the responsibility of the individual using / referencing this drawing to assure that the noted design revision level agrees with the revision level of the Controlled Document (Master Drawing). This is a NON-CONTROLLED DOCUMENT unless otherwise specifically noted.

DO NOT SCALE - Dimensional variation may occur during printing / reproduction.

Special Characteristics:

CC Critical Characteristic, relating to Safety and/or Regulatory Compliance

X Significant Characteristic relating to Process Control (SPC)

KC Key Characteristic relating to Form - Fit - Function as defined by Cole Hersee Company and/or the Customer

(Note that the identification of any Characteristics as being "Special" does not alter the requirement that ALL specified dimensions & tolerances must be met.)

Cole Hersee Co.
 20 Old Colony Ave., South Boston, MA, 02127
 Phn: 617-268-2100 Web: www.colehersee.com

Description: FEED THRU STUD

Drawing / Part No.: 46211-01

Current Rev.: L

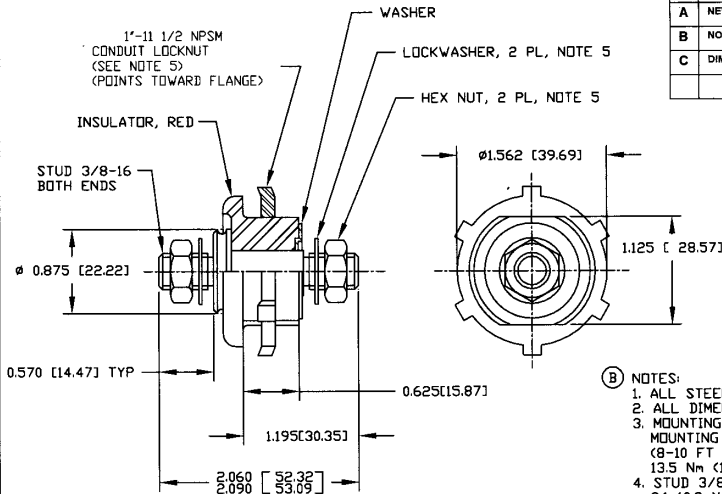

<u>Revision Control Record</u>			
Rev.	Description of Change	ECN No.	Date
A	NEW PART	02609	12/23/02
B	NOTES & VIEW	03189	5/30/03
C	DIMENSIONS & VIEW	03733	12/24/03

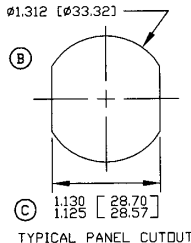

- (B) NOTES:
1. ALL STEEL PARTS PLATED
 2. ALL DIMENSIONS ARE REFERENCE ONLY
 3. MOUNTING THREADS 1'-11 1/2 NPSM-MOUNTING TORQUE 10.8-13.5 Nm (8-10 FT LBS) NOT TO EXCEED 13.5 Nm (10 FT LBS)
 4. STUD 3/8-16 TIGHTENING TORQUE 8.1-10.8 Nm (6-8 FT LBS)
 5. ALL HARDWARE SUPPLIED IN BAG

TOLERANCES - Unless otherwise specifically noted, the following are default tolerances:
 * 3-place Decimal Dimensions ±.02"
 * 3-place Decimal Dimensions ±.005"
 * Angular Dimensions ±1.0 Deg.
 * Metric: Refer to equivalent English Dimension Tolerance
 * >>> NOTE: All tolerances are Non-Cumulative. <<<

PROPRIETARY INFORMATION - This Engineering Drawing, and the information contained herein, is proprietary to Cole Hersee Company and may not be disclosed, re-produced, or in any other way transferred or communicated to any other party without the express written consent of an authorized representative of Cole Hersee Company.

DESIGN CONTROL - It is the responsibility of the individual using / referring this drawing to ensure that the noted design revision level agrees with the revision level of the Controlled Document (Drawing/Stamping). This is a NON-CONTROLLED DOCUMENT unless otherwise specifically noted.

DO NOT SCALE - Dimensional variation may occur during printing / reproduction.

Special Characteristics

- ⊠ Critical Characteristics, relating to Safety and/or Regulatory Compliance
- X Significant Characteristics relating to Process Control (SPC)
- (KC) Key Characteristics relating to Form - FE - Function as defined by Cole Hersee Company and/or the Customer

(Note that the identification of any Characteristics as being "Special" does not alter the requirement that ALL specified dimensions & tolerances must be met.)



Cole Hersee Co.

20 Old Colony Ave., South Boston, MA, 02127
 Phone 617-268-3100 Web: www.colehersee.com

Description:

FEED THRU STUD

Drawing / Part No.:

46211-R

Current Rev.

C

Revision Control Record

Rev.	Description of Change	ECN No.	Date
E	AUTOCAD, LOGO	05424	10/26/05
F	NOTE 2 CHANGE	06300	9/07/06
G	ADDED DIM	11233	7/20/11

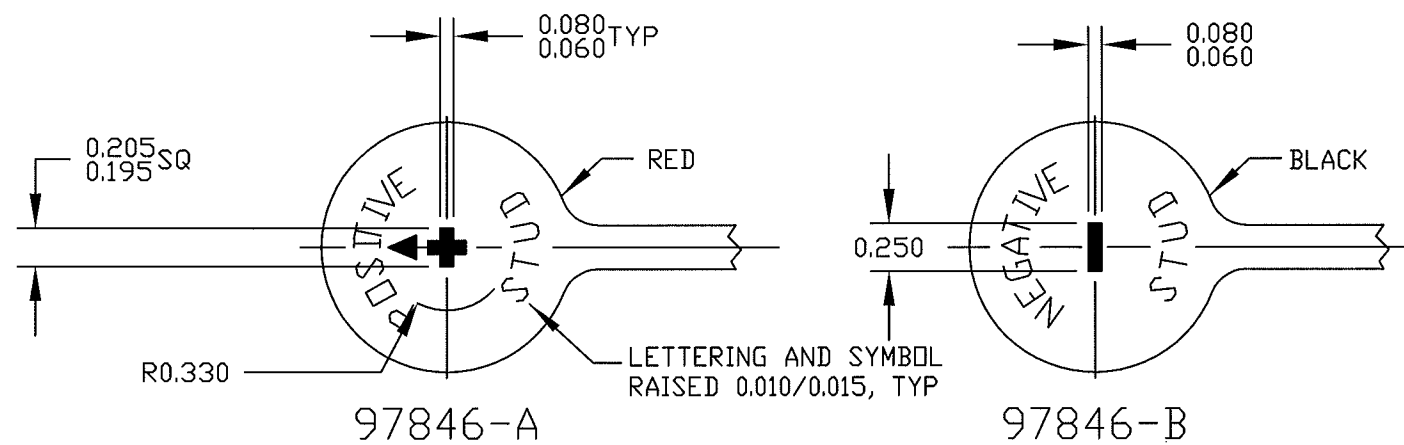
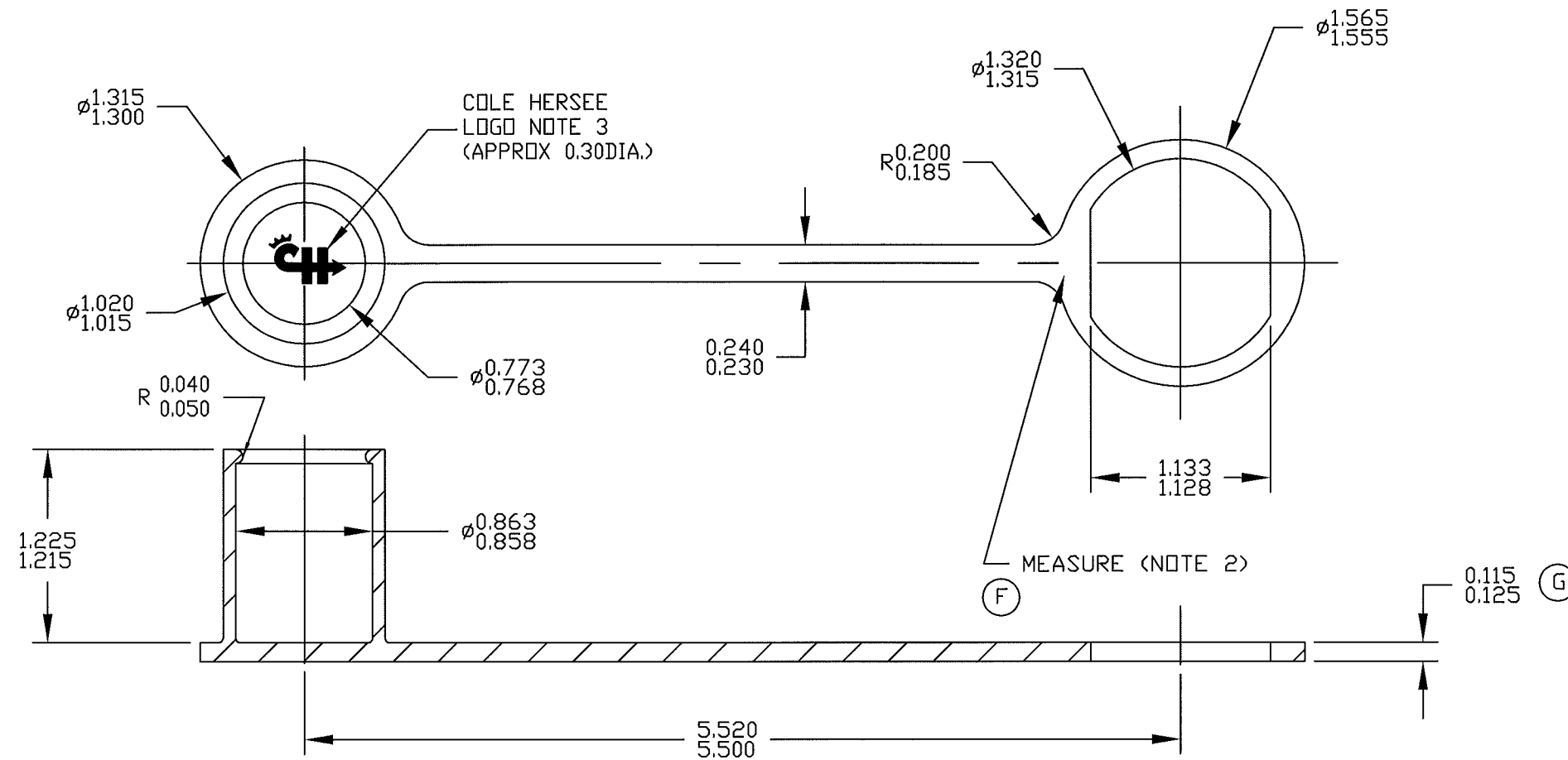

- NOTES:
 1. MATERIAL: COASTAL DC-834, PVC
 2. DURAMETER 60-75 SHORE A, PER ASTM SPEC. D-2287
 3. FOR LOGO PROPORTIONS SEE COLE HERSEE DRAWING TA 139

Tolerances Unless otherwise specifically noted, the following are default tolerances:
 * 2-place Decimal Dimensions +/- .02"
 * 3-place Decimal Dimensions +/- .005"
 * Angular Dimensions +/- 1.0 Deg.
 * Metric: Refer to equivalent English Dimension Tolerance
 >>> NOTE: All tolerances are Non-Cumulative. <<<

Dimensional Units All dimensions are expressed in inches except those shown in brackets (xxx) are expressed in millimeters

"REF." or an Asterisk (*) = Non-Toleranced Reference Dimension, shown for clarification purposes only.

Used On EX18810A-10
 or Ref.: 46210-01

PROPRIETARY INFORMATION This Engineering Drawing, and the information contained herein, is proprietary to Cole Hersee Company and may not be disclosed, re-produced, or in any other way transferred or communicated to any other party without the express written consent of an authorized representative of Cole Hersee Company.

DESIGN CONTROL It is the responsibility of the individual using/ referencing this drawing to assure that the noted design revision level agrees with the revision level of the Controlled Document (Master Drawing). This is a NON-CONTROLLED DOCUMENT unless otherwise specifically noted.

DO NOT SCALE - Dimensional variation may occur during printing/ reproduction.

Scale: **1:1**

Drawn By: **RMT**

Date Drawn: **6/19/80**

Special Characteristics:

- Critical Characteristic, relating to Safety and/or Regulatory Compliance
- Significant Characteristic relating to Process Control (SPC)
- Control Dimension relating to Form - Fit - Function as defined by Cole Hersee Company and/or the Customer

(Note that the identification of any Characteristics as being "Special" does not alter the requirement that ALL specified dimensions & tolerances must be met.)

Responsible Engineer: **SAM**

Pg. 1 of 1

Cole Hersee Co.
 20 Old Colony Ave., South Boston, MA, 02127
 Phn: 617-268-2100 Web: www.colehersee.com

Description:
CAP

Drawing / Part No.:
 97846-A & B

G



Компания «ЭлектроПласт» предлагает заключение долгосрочных отношений при поставках импортных электронных компонентов на взаимовыгодных условиях!

Наши преимущества:

- Оперативные поставки широкого спектра электронных компонентов отечественного и импортного производства напрямую от производителей и с крупнейших мировых складов;
- Поставка более 17-ти миллионов наименований электронных компонентов;
- Поставка сложных, дефицитных, либо снятых с производства позиций;
- Оперативные сроки поставки под заказ (от 5 рабочих дней);
- Экспресс доставка в любую точку России;
- Техническая поддержка проекта, помощь в подборе аналогов, поставка прототипов;
- Система менеджмента качества сертифицирована по Международному стандарту ISO 9001;
- Лицензия ФСБ на осуществление работ с использованием сведений, составляющих государственную тайну;
- Поставка специализированных компонентов (Xilinx, Altera, Analog Devices, Intersil, Interpoint, Microsemi, Aeroflex, Peregrine, Syfer, Eurofarad, Texas Instrument, Miteq, Cobham, E2V, MA-COM, Hittite, Mini-Circuits, General Dynamics и др.);

Помимо этого, одним из направлений компании «ЭлектроПласт» является направление «Источники питания». Мы предлагаем Вам помощь Конструкторского отдела:

- Подбор оптимального решения, техническое обоснование при выборе компонента;
- Подбор аналогов;
- Консультации по применению компонента;
- Поставка образцов и прототипов;
- Техническая поддержка проекта;
- Защита от снятия компонента с производства.



Как с нами связаться

Телефон: 8 (812) 309 58 32 (многоканальный)

Факс: 8 (812) 320-02-42

Электронная почта: org@eplast1.ru

Адрес: 198099, г. Санкт-Петербург, ул. Калинина, дом 2, корпус 4, литера А.