



IQS229EV01 module user guide

Single Channel Capacitive Proximity/Touch Controller for SAR Applications

Operation Characteristics

The IQS229 will work in standalone mode (STD – LED outputs) or streaming mode (STRM), depending on a resistor placement. By default the module will be configured in standalone mode.

- “OUT” (BLUE) LED will indicate an activation (crossing of the threshold)
- “MOV_OUT” (GREEN) LED will indicate movement in small detectable amounts.

Integration

Start the integration of the IQS229 by wiring the following into the intended application:

1. GND
2. CX (Electrode – wire or copper pad)
3. VDDHI

On-board LEDs may be used for feedback, or the OUT and MOV_OUT pins may be taken to a microcontroller.

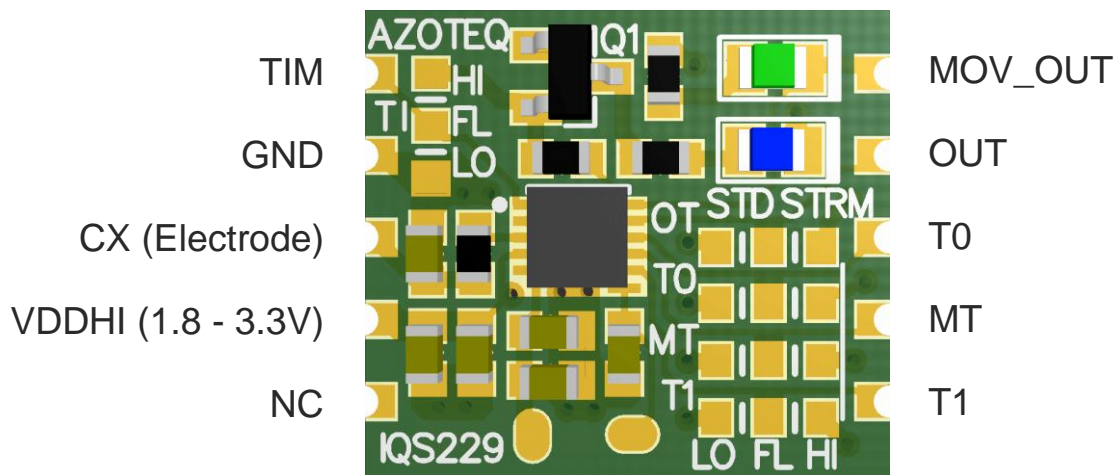

User Configurable Options

Four pins on the IQS229 are used for external configuration. Floating pins are the default configuration. The configuration is read at power-on or reset. To see how resistor straps are applied, see the next page.

Start off by choosing a threshold. T0 is used to set a large jump in threshold and T1 is used to set smaller offsets.

Next choose the preferred movement sensitivity by strapping MT.

Then choose a no movement time-out. If no movement is detected in this time, the sensor will clear the activation. With each movement the IQS229 will reset the timer.

Threshold Level Selection								
L = LOGIC LOW, H = LOGIC HIGH, F = FLOAT								
T0, THR0 (pin 8)								
L	L	L	F	F	F	H	H	H
T1, THR1 (pin 6)								
L	F	H	L	F	H	L	F	H
Corresponding Threshold Level								
0	1	2	3	4	5	6	7	8
◀ More sensitive					Less sensitive ▶			



Using resistor strap options

Resistor straps are used to configure the device as shown below. It is recommended to use a 1MΩ resistor for this purpose. After power-up or reset the values will be read and each pin is written with the values that was read. This eliminates potential leakage current.

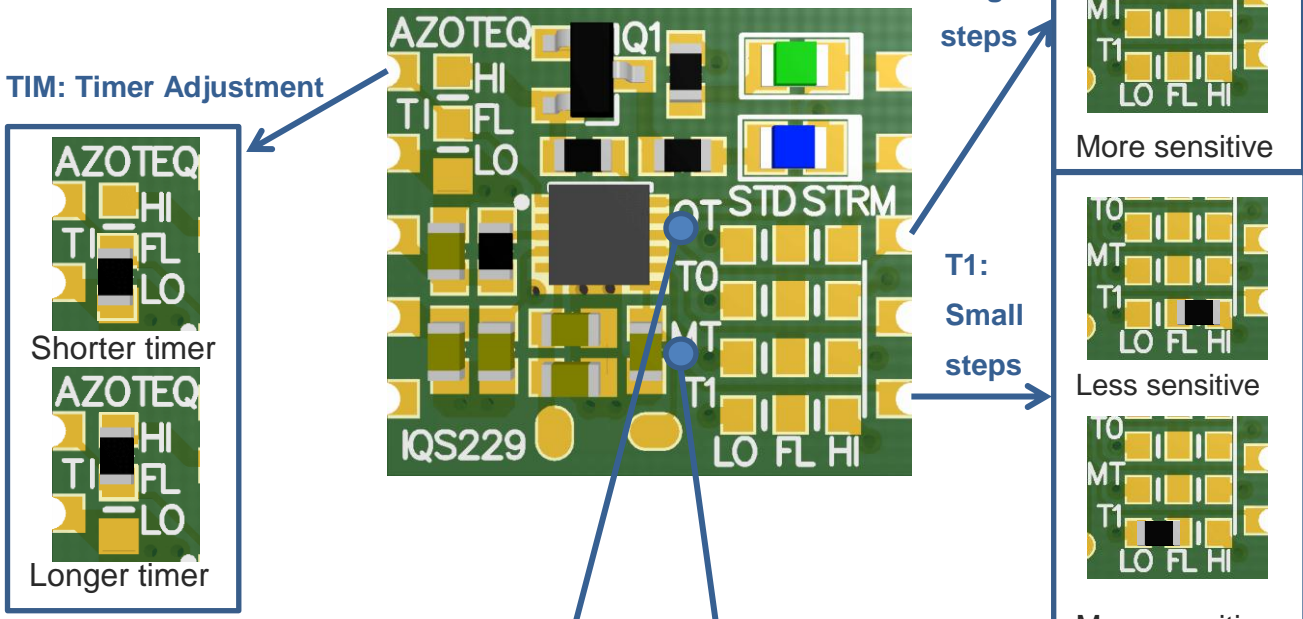

TIM (pin 1)	No Movement Time-out
Low	60sec
Float	3min
High	10min

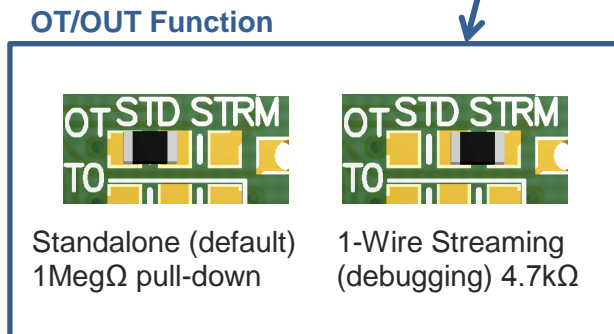

MT MOV_THR (pin 7)	Movement Threshold
Low	More sensitive
Float	Default
High	Less sensitive



Schematic and assembly

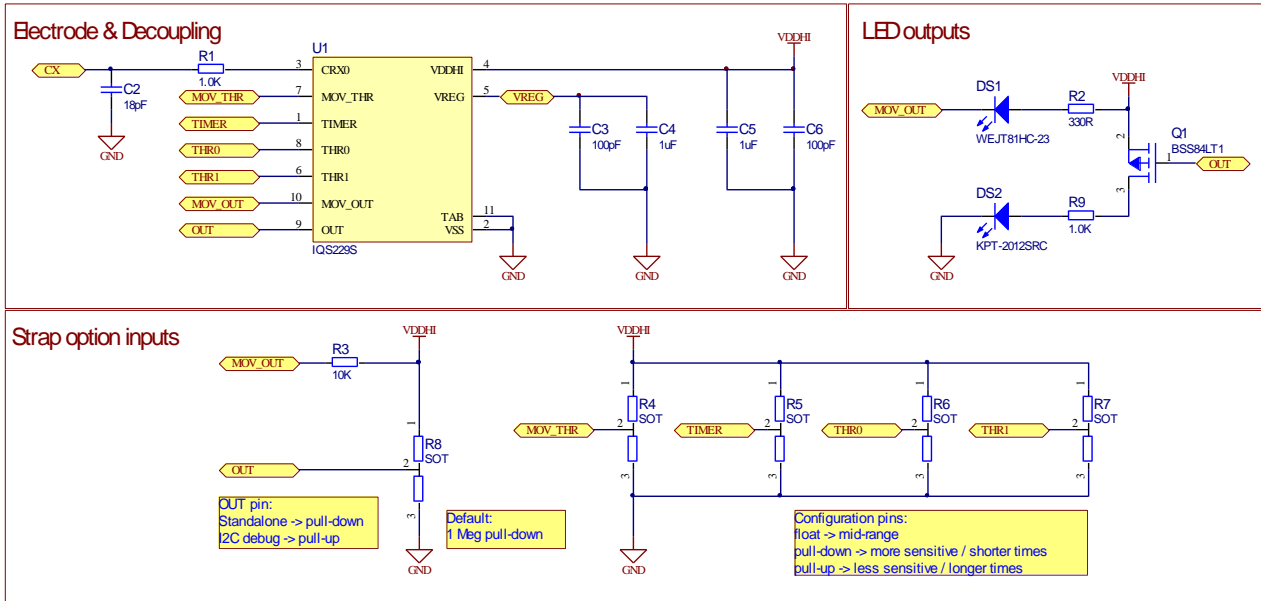

Figure 1 AZP408A05 Schematic

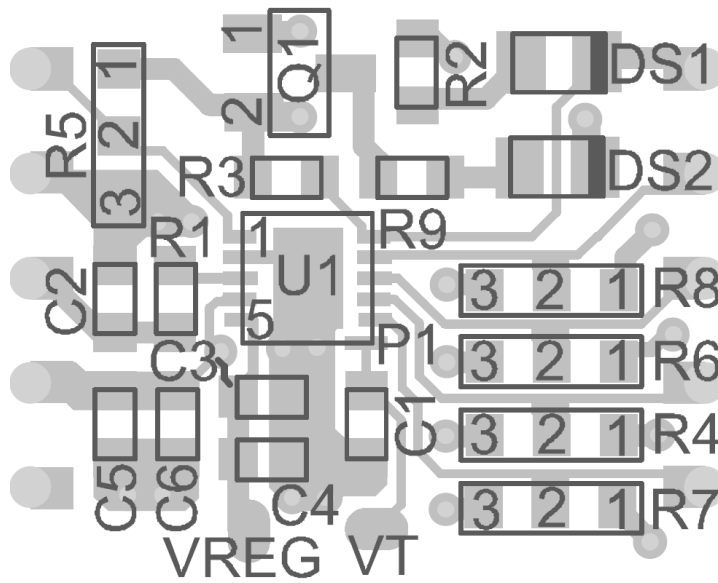

Figure 2 AZP408A05 assembly



Recommended landing pad

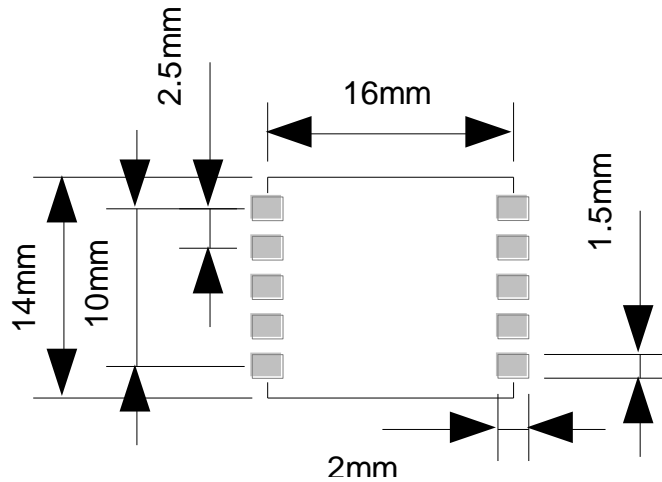

Figure 3 Recommended AZP408A05 landing pad

Programming

The IQS229 has various one-time-programmable (OTP) fuse options. Information about these options are available on request and are only recommended for larger orders (>50k) or when in-circuit programming is an option after the SMT process.

Connect the AZP408A05 to the CT210 as shown in Figure 4.

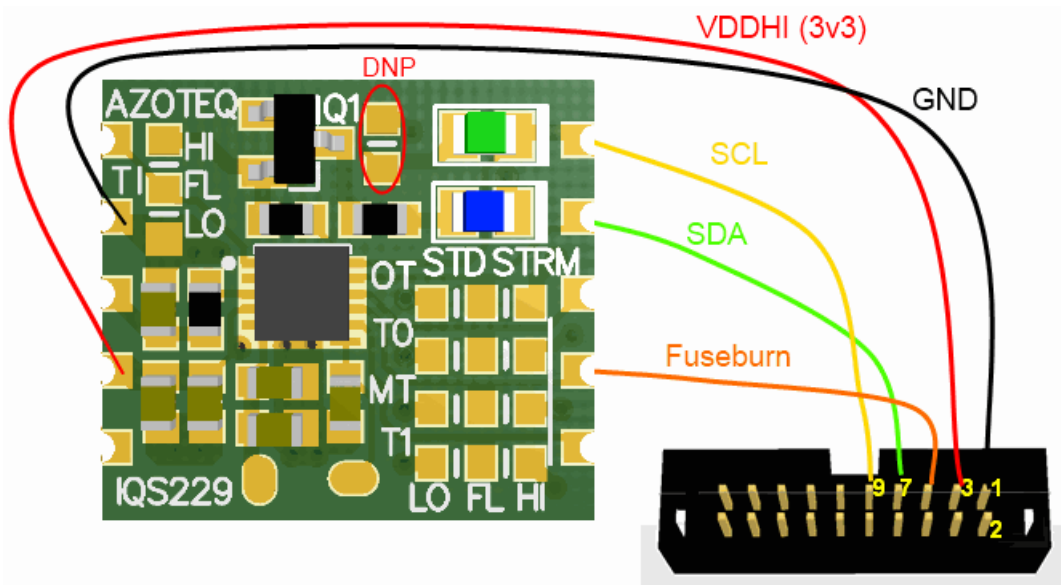

Figure 4 AZP408A05 connection to CT210 for IQS229 fuse burn

It is important to remove R2 when configuring the IQS229 OTP bits. The CT210 will configure the programming via I²C and the R2 / DS1 combination will cause the CLK line to become sluggish. Place R2 again after programming.

Program the IQS229 using the Azoteq [USBProg](#) utility.



Appendix A Contact Information

	USA	Asia	South Africa
Physical Address	6507 Jester Blvd Bldg 5, suite 510G Austin TX 78750 USA	Rm1725, Glittery City Shennan Rd Futian District Shenzhen, 518033 China	109 Main Street Paarl 7646 South Africa
Postal Address	6507 Jester Blvd Bldg 5, suite 510G Austin TX 78750 USA	Rm1725, Glittery City Shennan Rd Futian District Shenzhen, 518033 China	PO Box 3534 Paarl 7620 South Africa
Tel	+1 512 538 1995	+86 755 8303 5294 ext 808	+27 21 863 0033
Fax	+1 512 672 8442		+27 21 863 1512
Email	kobusm@azoteq.com	linayu@azoteq.com.cn	info@azoteq.com

Please visit www.azoteq.com for a list of distributors and worldwide representation.

The following patents relate to the device or usage of the device: US 6,249,089 B1, US 6,952,084 B2, US 6,984,900 B1, US 7,084,526 B2, US 7,084,531 B2, EP 1 120 018 B2, EP 1 206 168 B1, EP 1 308 913 B1, EP 1 530 178 A1, ZL 99 8 14357.X, AUS 761094, HK 104 14100A, US13/644,558, US13/873,418

IQ Switch®, SwipeSwitch™, ProxSense®, LightSense™, AirButton® and the  logo are trademarks of Azoteq.

The information in this Datasheet is believed to be accurate at the time of publication. Azoteq uses reasonable effort to maintain the information up-to-date and accurate, but does not warrant the accuracy, completeness or reliability of the information contained herein. All content and information are provided on a "as is" basis only, without any representations or warranties, express or implied, of any kind, including representations about the suitability of these products or information for any purpose. Azoteq disclaims all warranties and conditions with regard to these products and information, including but not limited to all implied warranties and conditions of merchantability, fitness for a particular purpose, title and non-infringement of any third party intellectual property rights. Azoteq assumes no liability for any damages or injury arising from any use of the information or the product or caused by, without limitation, failure of performance, error, omission, interruption, defect, delay in operation or transmission, even if Azoteq has been advised of the possibility of such damages. The applications mentioned herein are used solely for the purpose of illustration and Azoteq makes no warranty or representation that such applications will be suitable without further modification, nor recommends the use of its products for application that may present a risk to human life due to malfunction or otherwise. Azoteq products are not authorized for use as critical components in life support devices or systems. No licenses to patents are granted, implicitly, express or implied, by estoppel or otherwise, under any intellectual property rights. In the event that any of the abovementioned limitations or exclusions does not apply, it is agreed that Azoteq's total liability for all losses, damages and causes of action (in contract, tort (including without limitation, negligence) or otherwise) will not exceed the amount already paid by the customer for the products. Azoteq reserves the right to alter its products, to make corrections, deletions, modifications, enhancements, improvements and other changes to the content and information, its products, programs and services at any time or to move or discontinue any contents, products, programs or services without prior notification. For the most up-to-date information and binding Terms and Conditions please refer to www.azoteq.com.

WWW.AZOTEQ.COM

info@azoteq.com



Компания «ЭлектроПласт» предлагает заключение долгосрочных отношений при поставках импортных электронных компонентов на взаимовыгодных условиях!

Наши преимущества:

- Оперативные поставки широкого спектра электронных компонентов отечественного и импортного производства напрямую от производителей и с крупнейших мировых складов;
- Поставка более 17-ти миллионов наименований электронных компонентов;
- Поставка сложных, дефицитных, либо снятых с производства позиций;
- Оперативные сроки поставки под заказ (от 5 рабочих дней);
- Экспресс доставка в любую точку России;
- Техническая поддержка проекта, помощь в подборе аналогов, поставка прототипов;
- Система менеджмента качества сертифицирована по Международному стандарту ISO 9001;
- Лицензия ФСБ на осуществление работ с использованием сведений, составляющих государственную тайну;
- Поставка специализированных компонентов (Xilinx, Altera, Analog Devices, Intersil, Interpoint, Microsemi, Aeroflex, Peregrine, Syfer, Eurofarad, Texas Instrument, Miteq, Cobham, E2V, MA-COM, Hittite, Mini-Circuits, General Dynamics и др.);

Помимо этого, одним из направлений компании «ЭлектроПласт» является направление «Источники питания». Мы предлагаем Вам помощь Конструкторского отдела:

- Подбор оптимального решения, техническое обоснование при выборе компонента;
- Подбор аналогов;
- Консультации по применению компонента;
- Поставка образцов и прототипов;
- Техническая поддержка проекта;
- Защита от снятия компонента с производства.



Как с нами связаться

Телефон: 8 (812) 309 58 32 (многоканальный)

Факс: 8 (812) 320-02-42

Электронная почта: org@eplast1.ru

Адрес: 198099, г. Санкт-Петербург, ул. Калинина, дом 2, корпус 4, литера А.