

ISL98611A

High Efficiency Display Power and LED Driver for Smart Phones

FN8742
Rev.2.00
Sep 19, 2017

The [ISL98611A](#) is a high efficiency display power supply and LED driver for small size displays such as smart phones. It integrates a boost regulator, LDO, and inverting charge pump that are used to generate two output rails for the display power: +5V (default) and -5V (default). It also integrates a boost regulator and 3-channel current sinks for the LED backlight driver. The $\pm 5V$ output voltages can be adjusted from $\pm 4.5V$ up to $\pm 6V$.

ISL98611A extends the battery life of mobile devices by delivering greater than 87% efficiency for the display power function. For a backlight driver the ISL98611A uses nonsynchronous rectification, and by using a 3-channel topology the ISL98611A provides more than 90% efficiency. The ISL98611A integrates all compensation and feedback components, which minimizes BOM count and reduces the solution PCB size.

This product drives backlight LEDs with excellent current matching even at very low LED current ($\pm 2.2\%$ down to 1mA), improving the brightness uniformity of LCD displays. It includes analog, PWM and hybrid dimming to maximize LED efficiency while eliminating color shift issues.

The ISL98611A is offered in a $2.33 \times 2.61 \text{mm}^2$ WLCSP package, and is specified for operation across the -40°C to $+85^\circ\text{C}$ ambient temperature range.

Related Literature

- For a full list of related documents, visit our website - [ISL98611A](#) product page

Features

- >87% efficiency with 12mA load between VP and VN
- More than 90% efficient LED driver
- Only 9 external components; integrated compensation and feedback circuits
- Analog, PWM and hybrid dimming
- $\pm 2.2\%$ current matching down to 1mA
- Can drive 2 or 3 strings of LEDs
- 35V maximum VLED voltage
- 10-bit linear and 11-bit logarithmic DC output current control
- I²C, PWM and SWIRE dimming inputs with internal multiplier for CABC
- 2.5V to 5V input voltage range
- VP and VN output adjustable from $\pm 4.5V$ up to $\pm 6V$ with 50mV steps
- I²C adjustable output voltages and settings
- 1 μ A shutdown supply current
- Pb-free (RoHS compliant)

Applications

- TFT-LCD smart phone displays
- Small size/handheld display

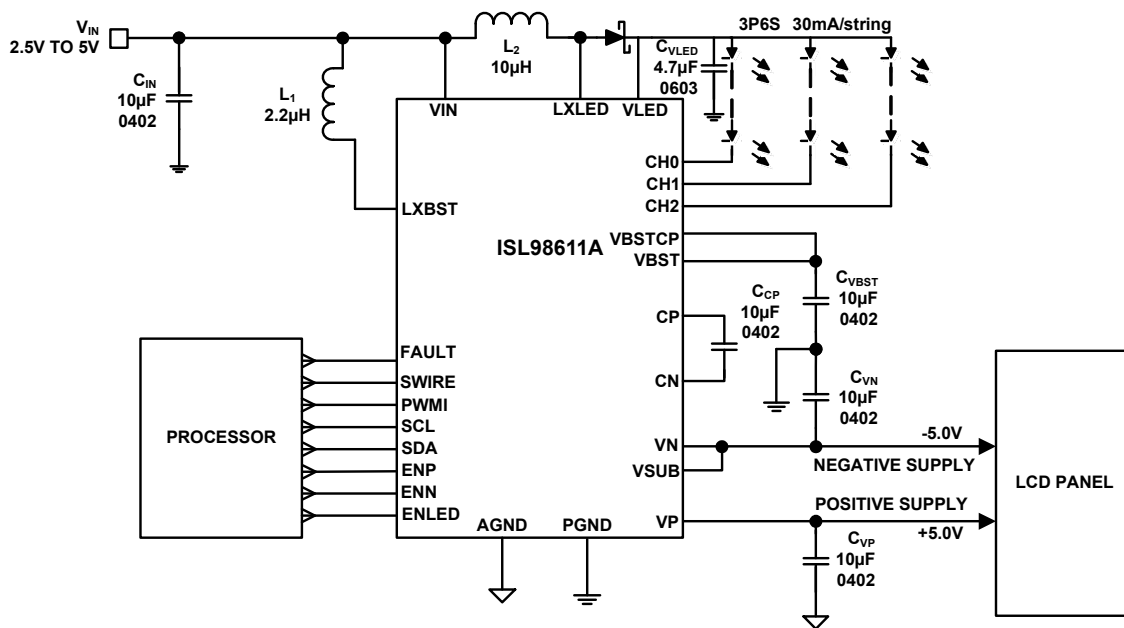

FIGURE 1. TYPICAL APPLICATION CIRCUIT FOR 3-CHANNEL LED DRIVER

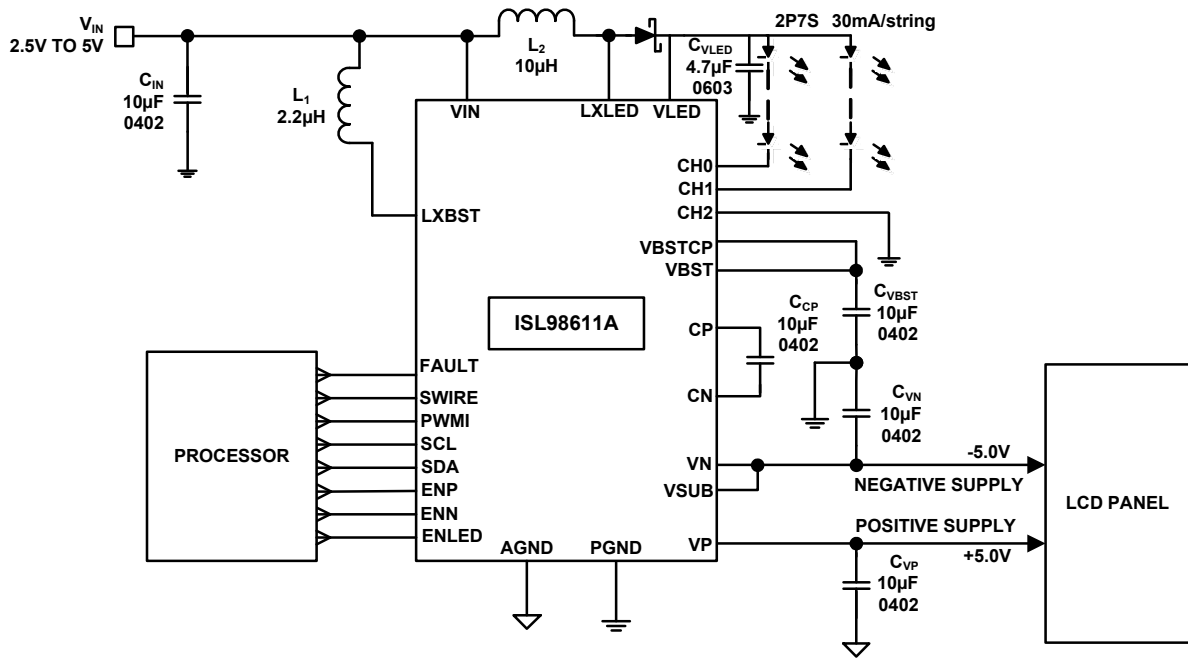

FIGURE 2. TYPICAL APPLICATION CIRCUIT FOR 2-CHANNEL LED DRIVER

© Copyright Intersil Americas LLC 2015-2017. All Rights Reserved.
 All trademarks and registered trademarks are the property of their respective owners.

For additional products, see www.intersil.com/en/products.html

Intersil products are manufactured, assembled and tested utilizing ISO9001 quality systems as noted in the quality certifications found at www.intersil.com/en/support/qualandreliability.html

Intersil products are sold by description only. Intersil may modify the circuit design and/or specifications of products at any time without notice, provided that such modification does not, in Intersil's sole judgment, affect the form, fit or function of the product. Accordingly, the reader is cautioned to verify that datasheets are current before placing orders. Information furnished by Intersil is believed to be accurate and reliable. However, no responsibility is assumed by Intersil or its subsidiaries for its use; nor for any infringements of patents or other rights of third parties which may result from its use. No license is granted by implication or otherwise under any patent or patent rights of Intersil or its subsidiaries.

For information regarding Intersil Corporation and its products, see www.intersil.com



Компания «ЭлектроПласт» предлагает заключение долгосрочных отношений при поставках импортных электронных компонентов на взаимовыгодных условиях!

Наши преимущества:

- Оперативные поставки широкого спектра электронных компонентов отечественного и импортного производства напрямую от производителей и с крупнейших мировых складов;
- Поставка более 17-ти миллионов наименований электронных компонентов;
- Поставка сложных, дефицитных, либо снятых с производства позиций;
- Оперативные сроки поставки под заказ (от 5 рабочих дней);
- Экспресс доставка в любую точку России;
- Техническая поддержка проекта, помощь в подборе аналогов, поставка прототипов;
- Система менеджмента качества сертифицирована по Международному стандарту ISO 9001;
- Лицензия ФСБ на осуществление работ с использованием сведений, составляющих государственную тайну;
- Поставка специализированных компонентов (Xilinx, Altera, Analog Devices, Intersil, Interpoint, Microsemi, Aeroflex, Peregrine, Syfer, Eurofarad, Texas Instrument, Miteq, Cobham, E2V, MA-COM, Hittite, Mini-Circuits, General Dynamics и др.);

Помимо этого, одним из направлений компании «ЭлектроПласт» является направление «Источники питания». Мы предлагаем Вам помощь Конструкторского отдела:

- Подбор оптимального решения, техническое обоснование при выборе компонента;
- Подбор аналогов;
- Консультации по применению компонента;
- Поставка образцов и прототипов;
- Техническая поддержка проекта;
- Защита от снятия компонента с производства.



Как с нами связаться

Телефон: 8 (812) 309 58 32 (многоканальный)

Факс: 8 (812) 320-02-42

Электронная почта: org@eplast1.ru

Адрес: 198099, г. Санкт-Петербург, ул. Калинина, дом 2, корпус 4, литера А.