

LOC	DIST	REVISIONS					
GP	00	P	LTH	DESCRIPTION	DATE	DWN	APVD
		A		INITIAL RELEASE	13MAR2017	LL	SH
		B		REVISED PER ECO-17-012744	31AUG2017	TX	SH

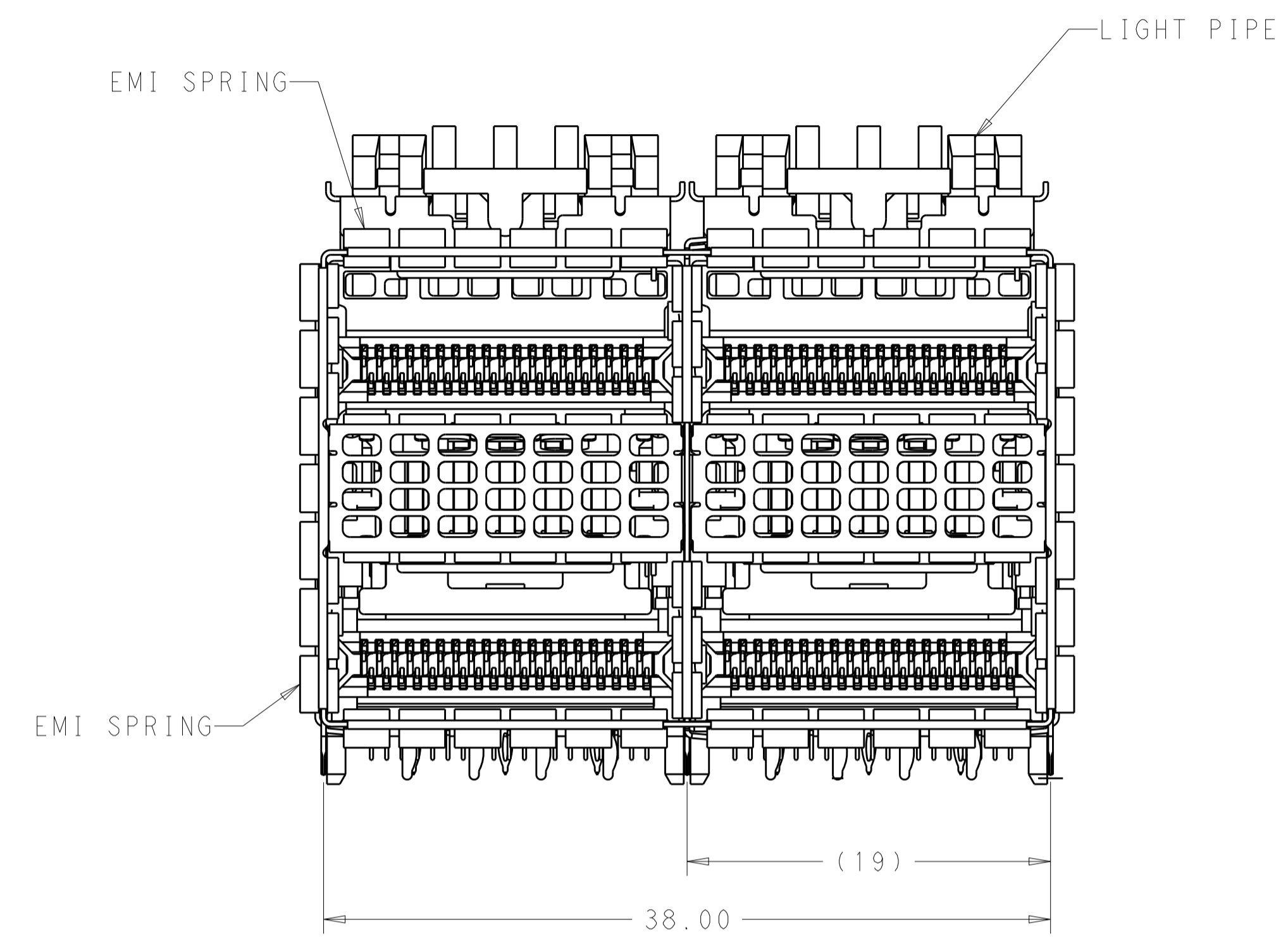

2299870-1

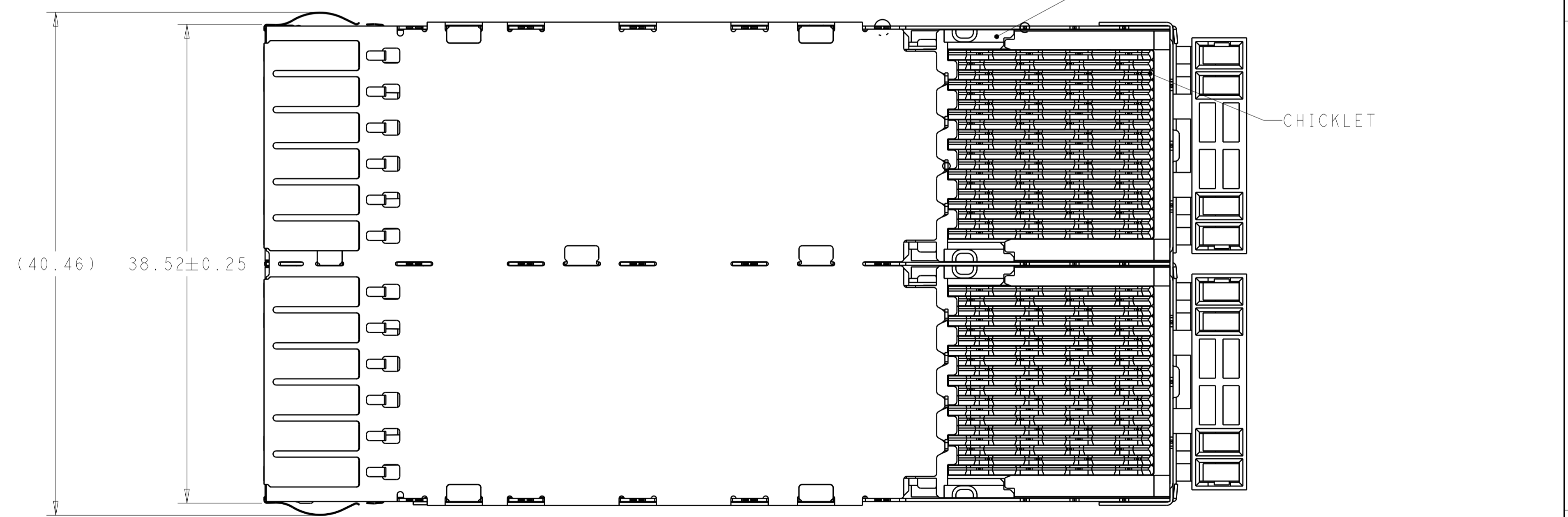
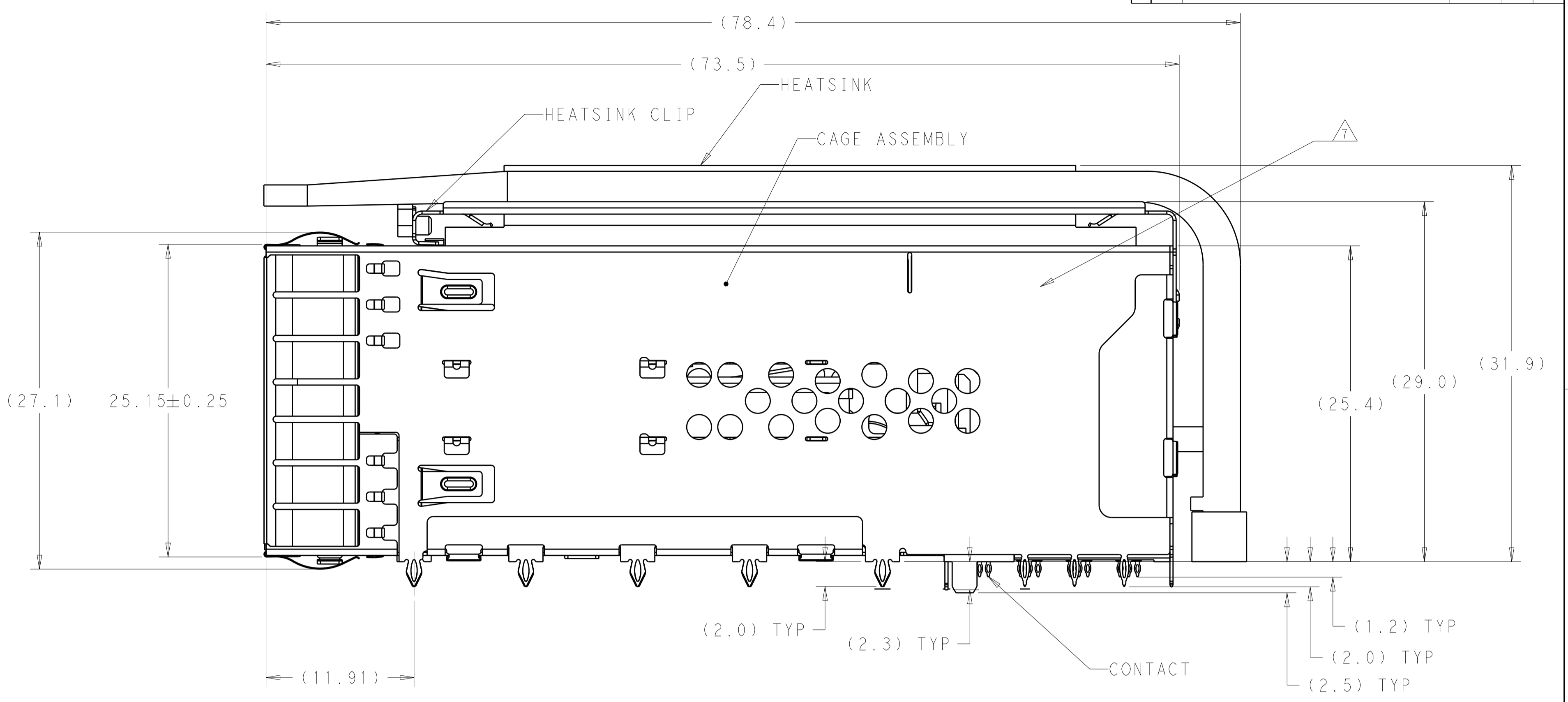

1. MATERIALS:
 CAGE ASSEMBLY- NICKEL SILVER ALLOY PER ASTM B 122.
 EMI SPRING- COPPER ALLOY, NICKEL PLATED.
 HOUSING- POLYESTER LCP WITH 94V-0.
 CHICKLET- POLYESTER LCP WITH 94V-0.
 CONTACT- COPPER ALLOY.
 LIGHTPIPE- POLYCARBONATE WITH 94V-0.
2. CONTACT FINISH: 0.76µm GOLD ON MATING AREA, 0.7-1.5µm MATT TIN ON COMPLIANT AREA, ALL OVER 1.27µm NICKEL.
3. DATUM AND BASIC DIMENSION ESTABLISHED BY CUSTOMER.
4. MINIMUM PCB THICKNESS OF 1.57.
5. THE ENTIRE AREA OF THE CONNECTOR FOOTPRINT, INDICATED BY THE DASHED LINE, TO BE CONSIDERED THE KEEPOUT AREA FOR COMPONENTS AND TRACES.
6. CROSS-HATCHED AREAS REPRESENT ZONES ON THE PCB THAT COME IN CONTACT WITH OR BE IN CLOSE PROXIMITY TO THE PLASTIC HOUSING OR THE CONNECTOR CAGE. INDICATED AREAS TO BE CONSIDERED TRACE FREE.
7. PART NUMBER AND DATE CODE MAKED IN APPROXIMATE AREA SHOWN.
8. HATCHED AREA IS PLACEMENT ZONE FOR LED. LED SHOULD BE CENTERED WITHIN ZONE. RECOMMEND 0805 PACKAGE.
9. CONTACT FINISH: 0.08µm MINIMUM GOLD OVER 0.68µm PALLADIUM-NICKEL ON MATING AREA, 0.7-1.5µm MATT TIN ON COMPLIANT AREA, ALL OVER 1.27µm NICKEL.

CONTACT FINISH	DESCRIPTION	PART NUMBER
2	WITH HS & WITHOUT LP	2299870-6
2	WITHOUT UPPER HS OR LP	2299870-5
2	WITHOUT UPPER HS OR LP	2299870-4
2	WITH HS & WITHOUT LP	2299870-3
2	WITH HS & WITHOUT LP	2299870-2
2	WITH HS & WITH LP	2299870-1

THIS DRAWING IS A CONTROLLED DOCUMENT.

OWN: TIM XUE 28JAN2016
 CHG: SEAN HAN 28JAN2016
 APVD: SEAN HAN 28JAN2016

DIMENSIONS: mm
 TOLERANCES UNLESS OTHERWISE SPECIFIED:
 0 PLC ±
 1 PLC ±0.25
 2 PLC ±0.15
 3 PLC ±
 4 PLC ±
 ANGLES ° ±
 FINISH

MATERIAL: SEE NOTE 1
 SEE NOTE 2

PRODUCT SPEC: 108-60102
 APPLICATION SPEC: 114-60015

WEIGHT: -
 CUSTOMER DRAWING

NAME: SEAN HAN
 SIZE: A1
 CAGE CODE: 100779
 DRAWING NO: 2299870

RESTRICTED TO: -

SCALE: 4:1
 SHEET: 1 OF 8
 REV: B

TE Connectivity

CAGE AND CONNECTOR ASSEMBLY WITH EMI SPRING FINGERS, THRU BEZEL, 2X2 ZQSFP+ STACKED WITH HS

LOC	DIST	REVISIONS					
GP	00	P	LYR	DESCRIPTION	DATE	OWN	APVD
		-		SEE SHEET 1			

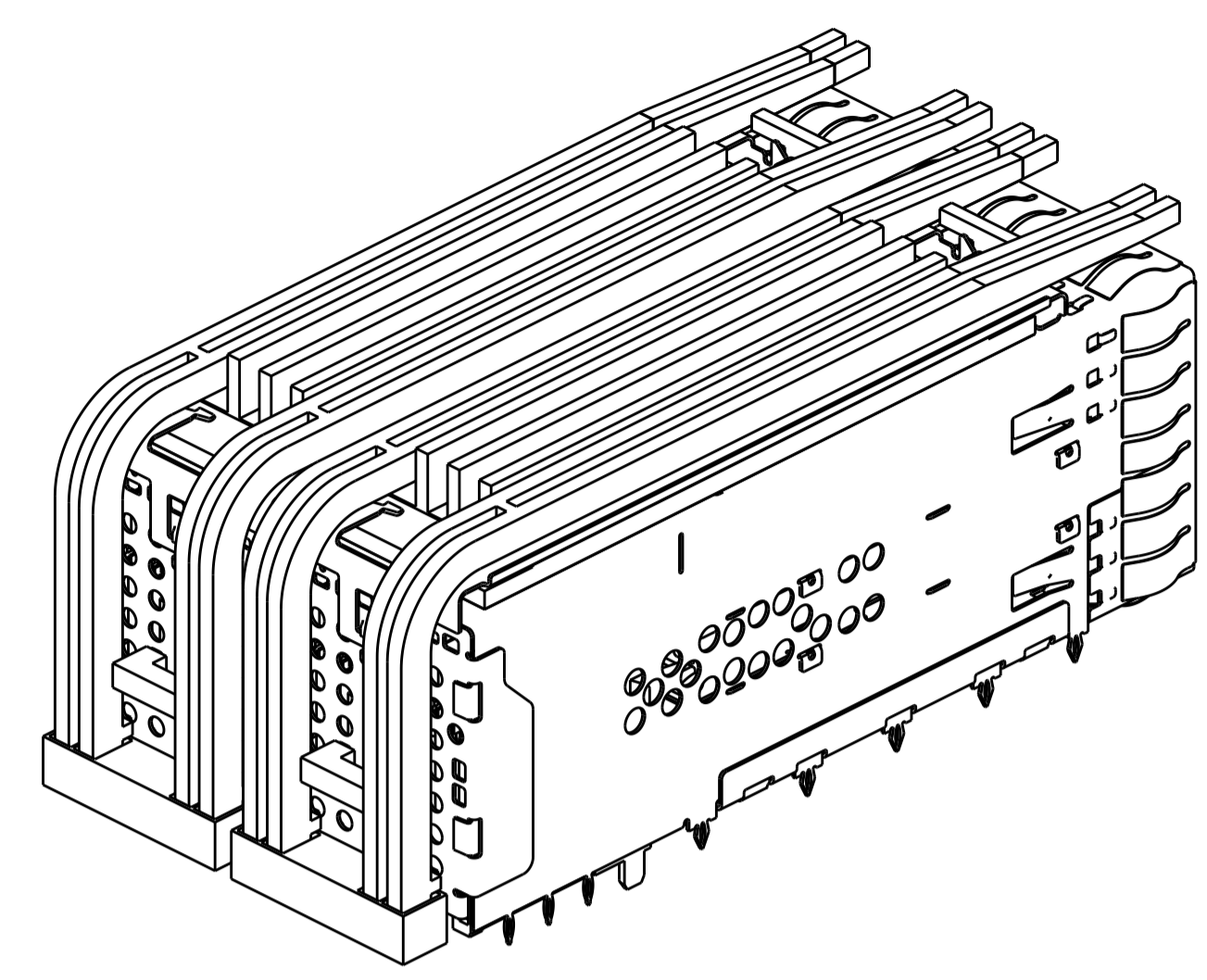

2299870-1 AS SHOWN
SCALE 2:1

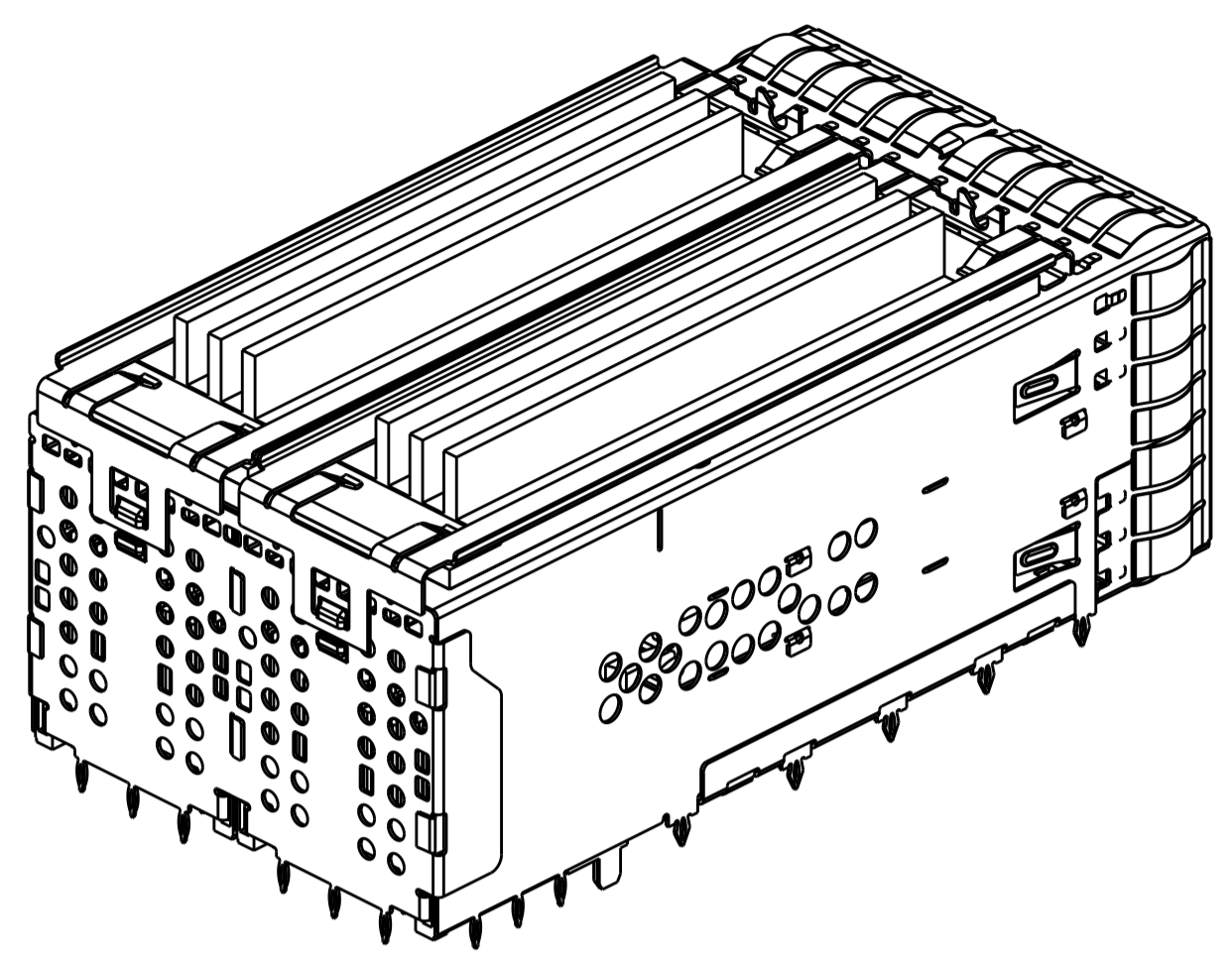

2299870-2 AS SHOWN
SAME AS 2299870-1 EXCEPT
W/O LEGHT PIPE AND ORGANIZER
SCALE 2:1

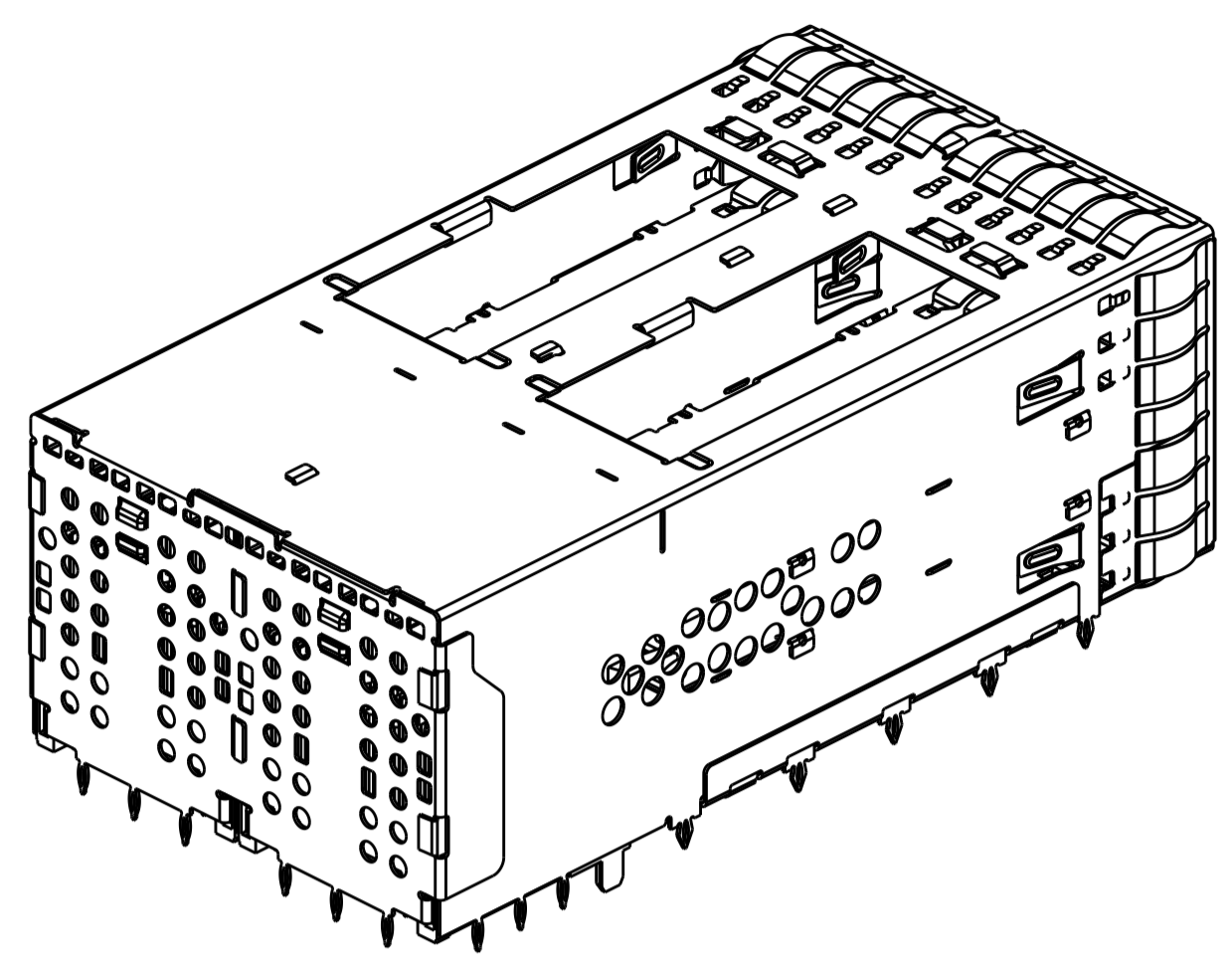

2299870-4 AS SHOWN
SAME AS 2299870-2 EXCEPT
W/O EXTERNAL HEAT SINK AND LP
SCALE 2:1

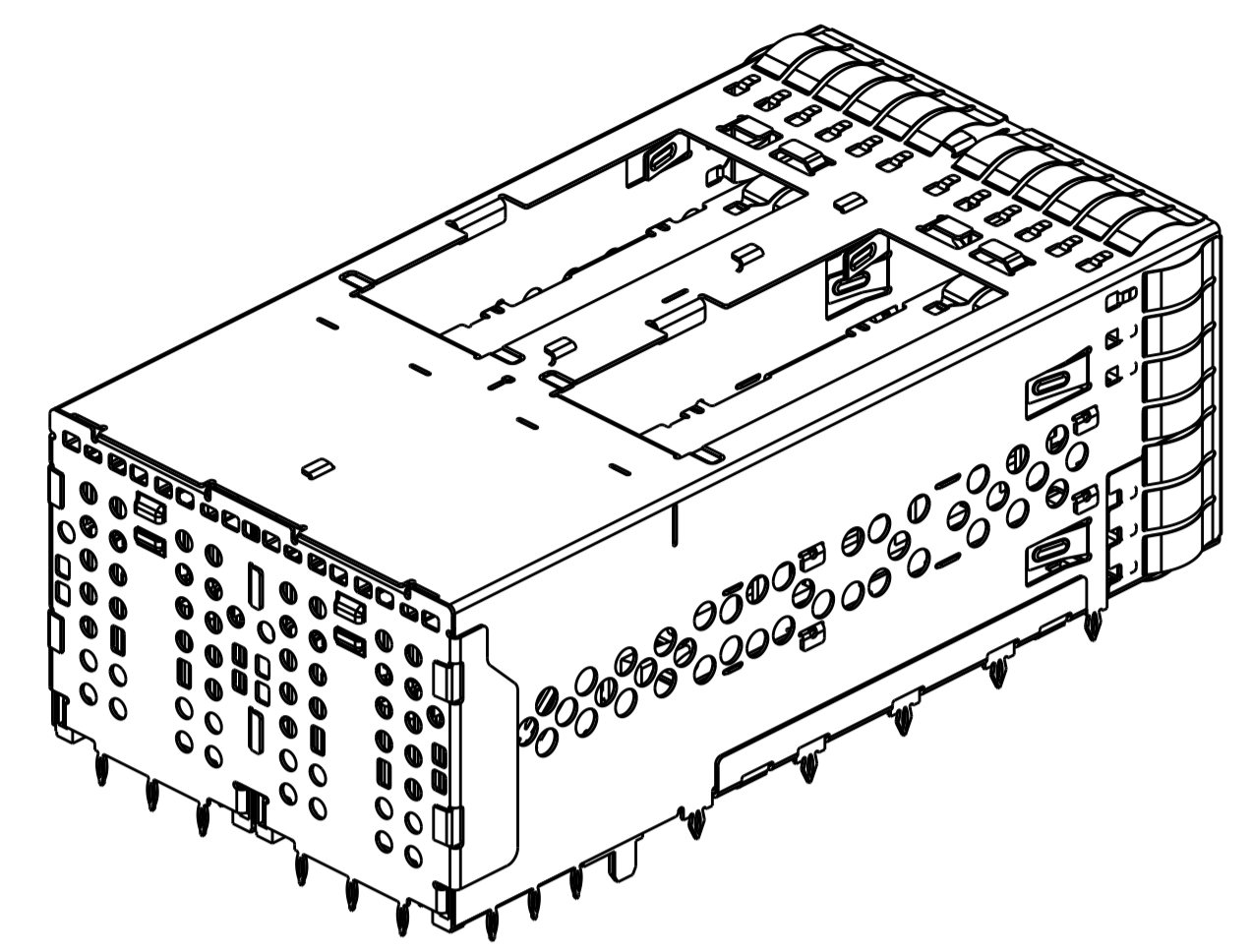

2299870-5
SCALE 2:1

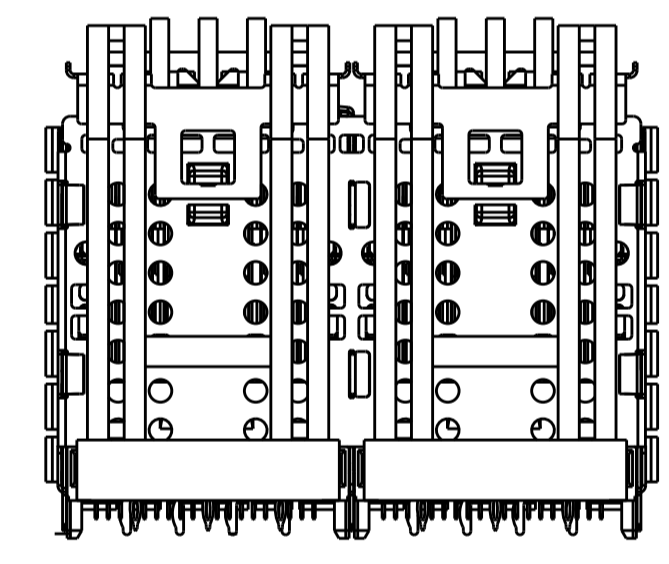

2299870-1
SCALE 2:1

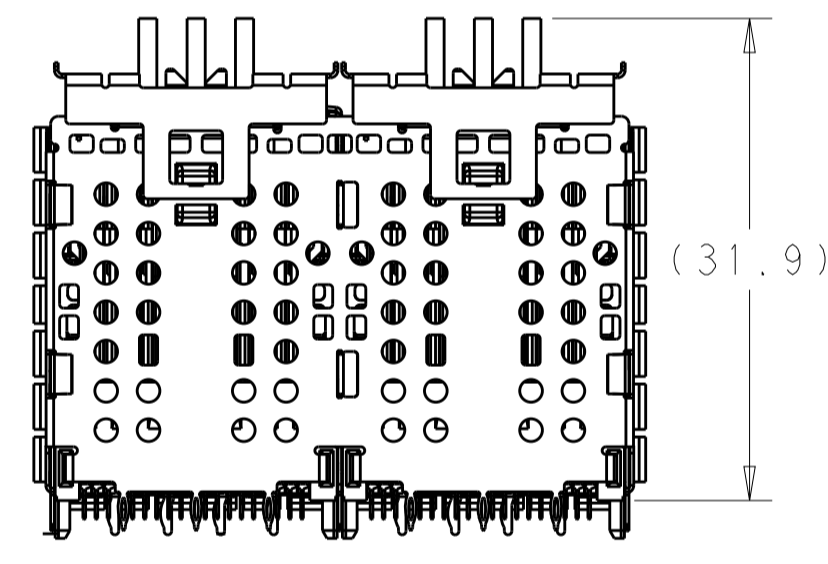

2299870-2
SCALE 2:1

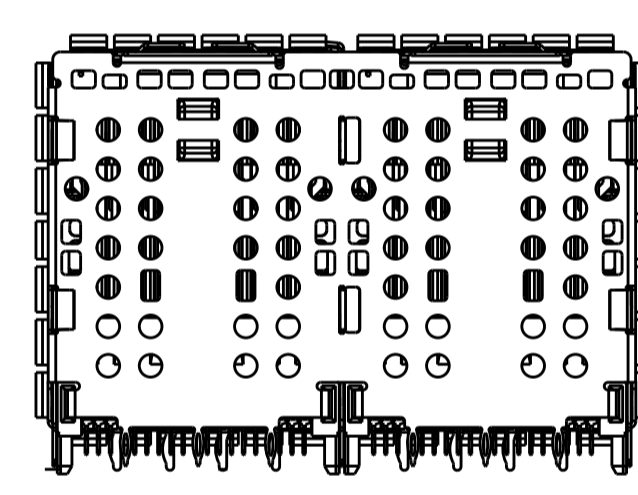

2299870-4
SCALE 2:1

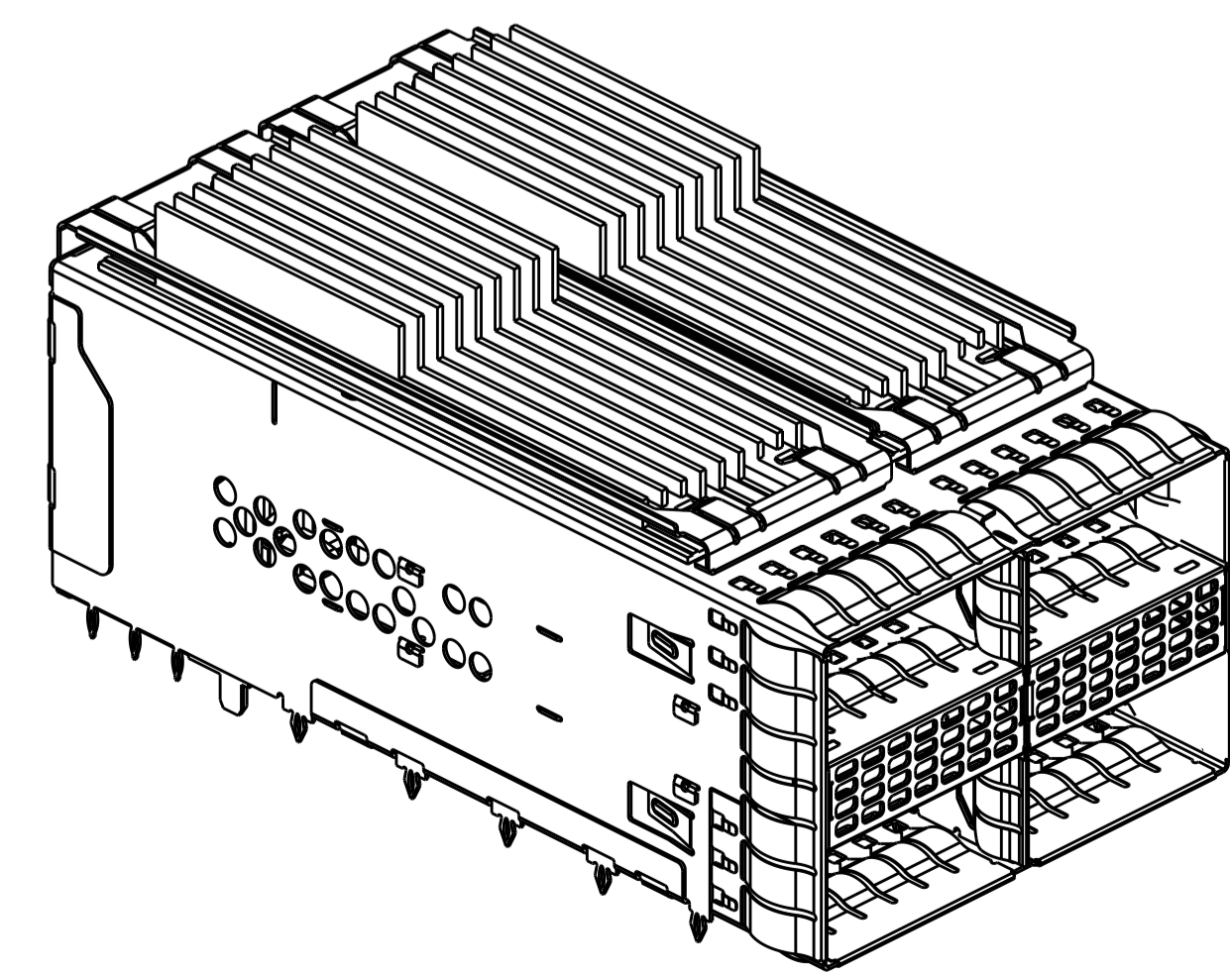
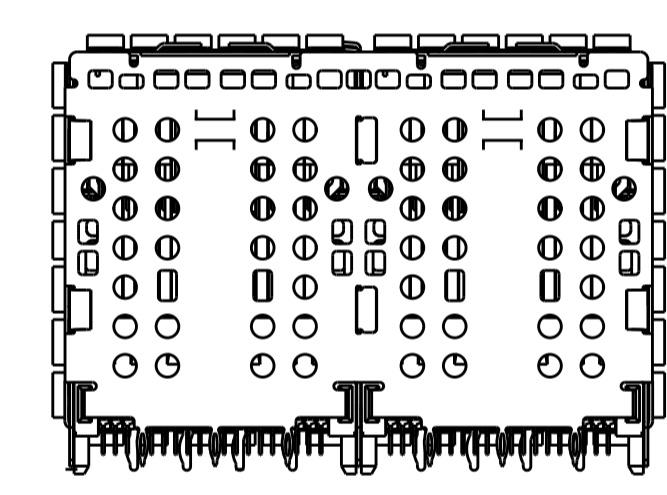

2299870-6
SCALE 2:1

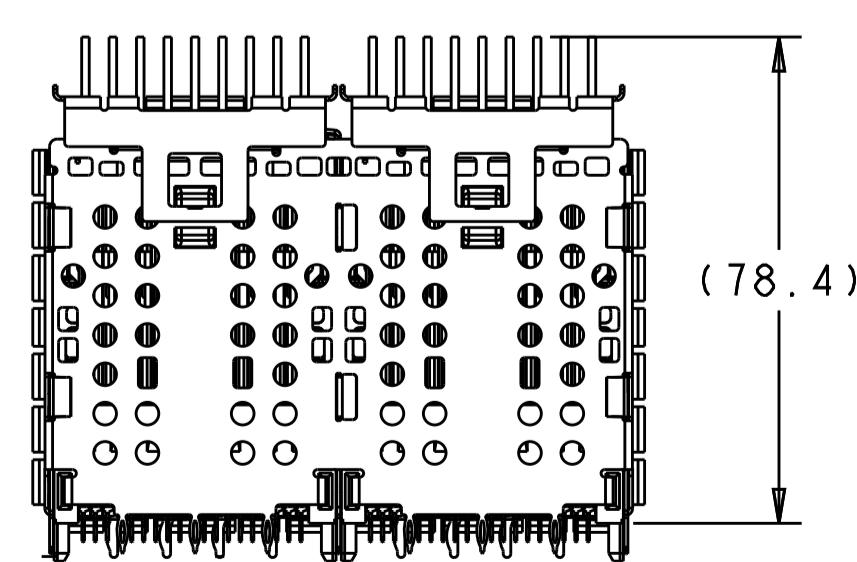

2299870-6
SCALE 2:1

THIS DRAWING IS A CONTROLLED DOCUMENT.		OWN: TIM XUE 28JAN2016											
DIMENSIONS: mm		CHK: SEAN HAN 28JAN2016											
TOLERANCES UNLESS OTHERWISE SPECIFIED:		APVD: SEAN HAN 28JAN2016	NAME: CAGE AND CONNECTOR ASSEMBLY WITH EMI SPRING FINGERS, THRU BEZEL, 2X2 ZQSFP+ STACKED WITH HS										
<table border="1"> <tr><td>0 PLC</td><td>±</td></tr> <tr><td>1 PLC</td><td>±0.25</td></tr> <tr><td>2 PLC</td><td>±0.15</td></tr> <tr><td>3 PLC</td><td>±</td></tr> <tr><td>4 PLC</td><td>±</td></tr> </table>		0 PLC	±	1 PLC	±0.25	2 PLC	±0.15	3 PLC	±	4 PLC	±	PRODUCT SPEC: 108-60102	SIZE: 114-60015
0 PLC	±												
1 PLC	±0.25												
2 PLC	±0.15												
3 PLC	±												
4 PLC	±												
MATERIAL: SEE NOTE 1		APPLICATION SPEC: 114-60015	RESTRICTED TO: A100779C=2299870										
FINISH: SEE NOTE 2		WEIGHT: -	SCALE: 4:1 SHEET 2 OF 8 REV B										
CUSTOMER DRAWING													

LOC	DIST	REVISIONS					
GP	00	P	LYR	DESCRIPTION	DATE	DWN	APVD
-	-	-	-	SEE SHEET 1	-	-	-

2299870-3 AS SHOWN, KIT PACKAGE

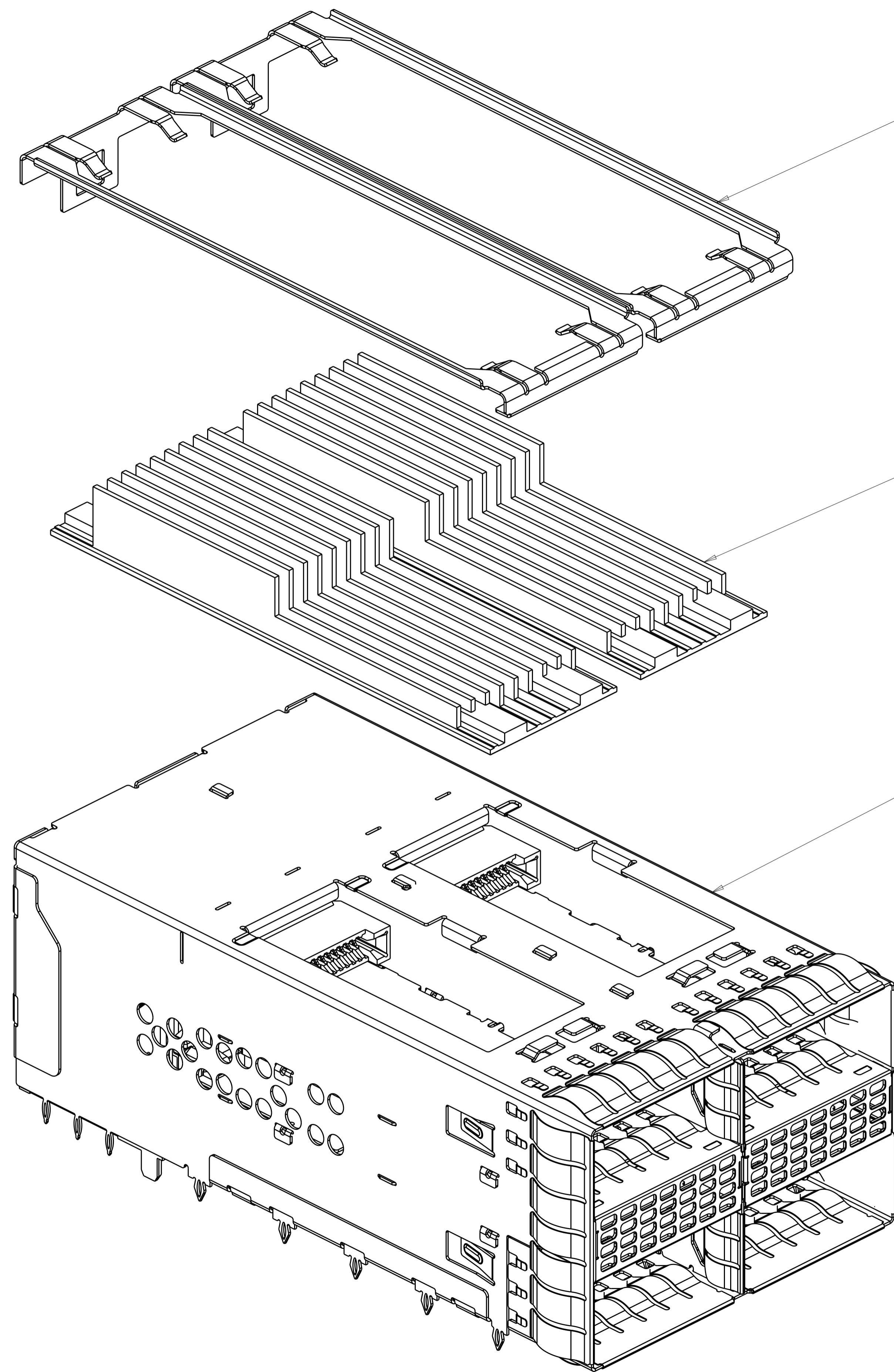

HEAT SINK CLIP
 PN: 1-2300832-7

HEAT SINK
 PN: 1-2304280-3

CAGE AND CONNECTOR ASSEMBLY
 PN: 2299870-4

SCALE 4:1

2	1-2300832-7	HEAT SINK CLIP	3
2	1-2304280-3	HEAT SINK	2
1	2299870-4	CAGE AND CONNECTOR ASSEMBLY	1
2299870-3	PART NUMBER	DESCRIPTION	ITEM

THIS DRAWING IS A CONTROLLED DOCUMENT.		OWN	TIM XUE	28JAN2016
DIMENSIONS:		CHK	SEAN HAN	28JAN2016
mm	TOLERANCES UNLESS OTHERWISE SPECIFIED:	APVD	SEAN HAN	28JAN2016
	0 PLC ±	NAME	CAGE AND CONNECTOR ASSEMBLY WITH EMI SPRING FINGERS, THRU BEZEL, 2X2 ZQSFP+ STACKED WITH HS	
	1 PLC ±0.25	PRODUCT SPEC	108-60102	
	2 PLC ±0.15	APPLICATION SPEC	114-60015	
	3 PLC ±	SIZE	A1	00779
	4 PLC ±	CAGE CODE	C=2299870	
	ANGLES ±	DRAWING NO	CUSTOMER DRAWING	
MATERIAL	FINISH	WEIGHT	SCALE	4:1
SEE NOTE 1	SEE NOTE 2		SHEET	3 OF 8
		RESTRICTED TO	REV	B

LOC	DIST	REVISIONS			
P	LTN	DESCRIPTION	DATE	DMN	APVD
-	-	SEE SHEET 1	-	-	-

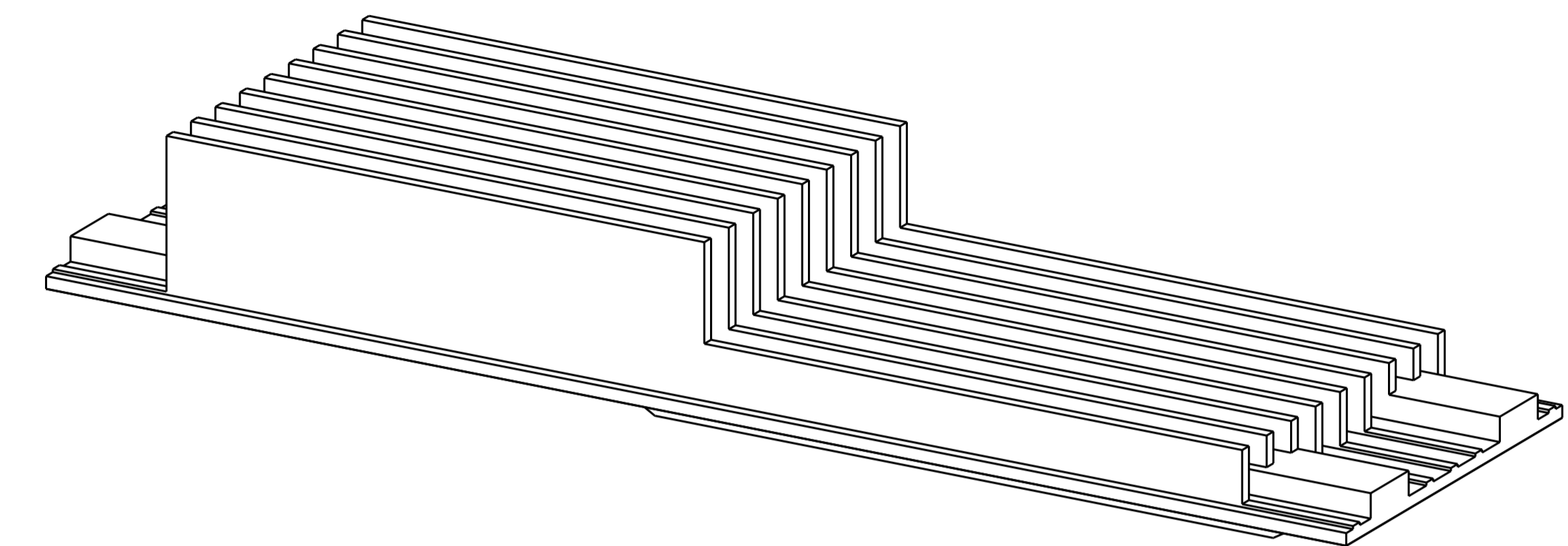
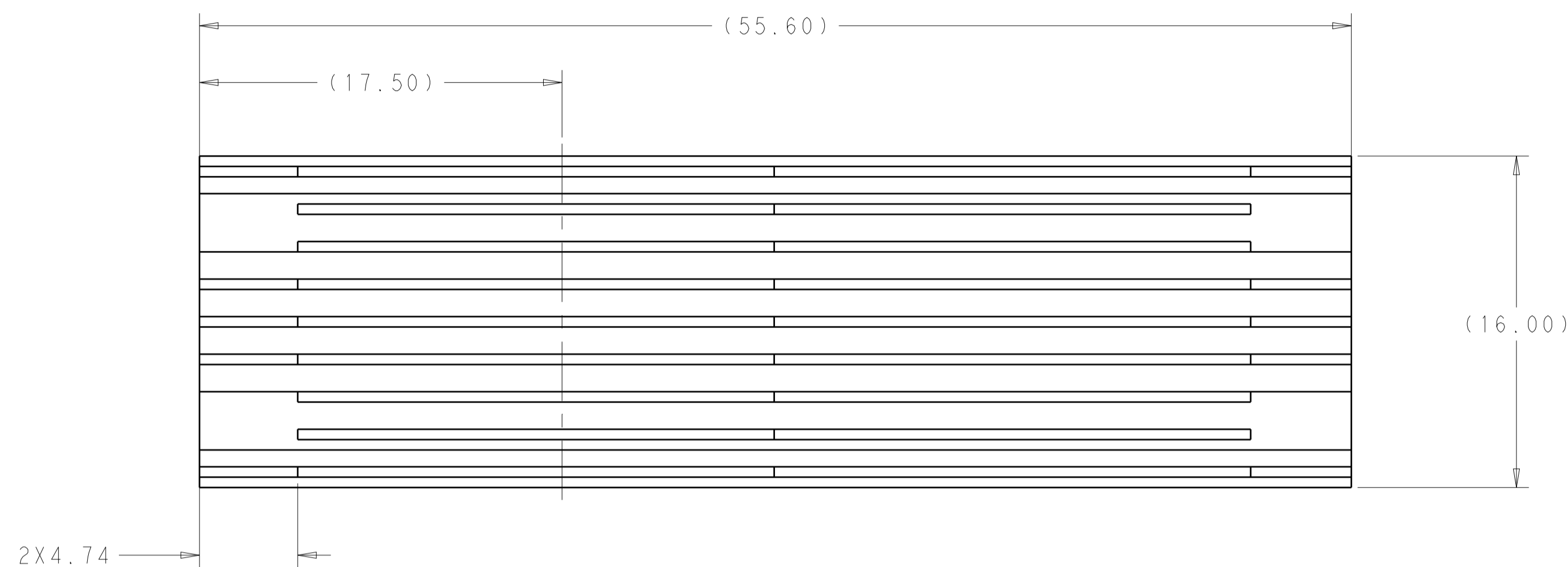

1-2304280-3 HEAT SINK SHOWN
SCALE 5:1

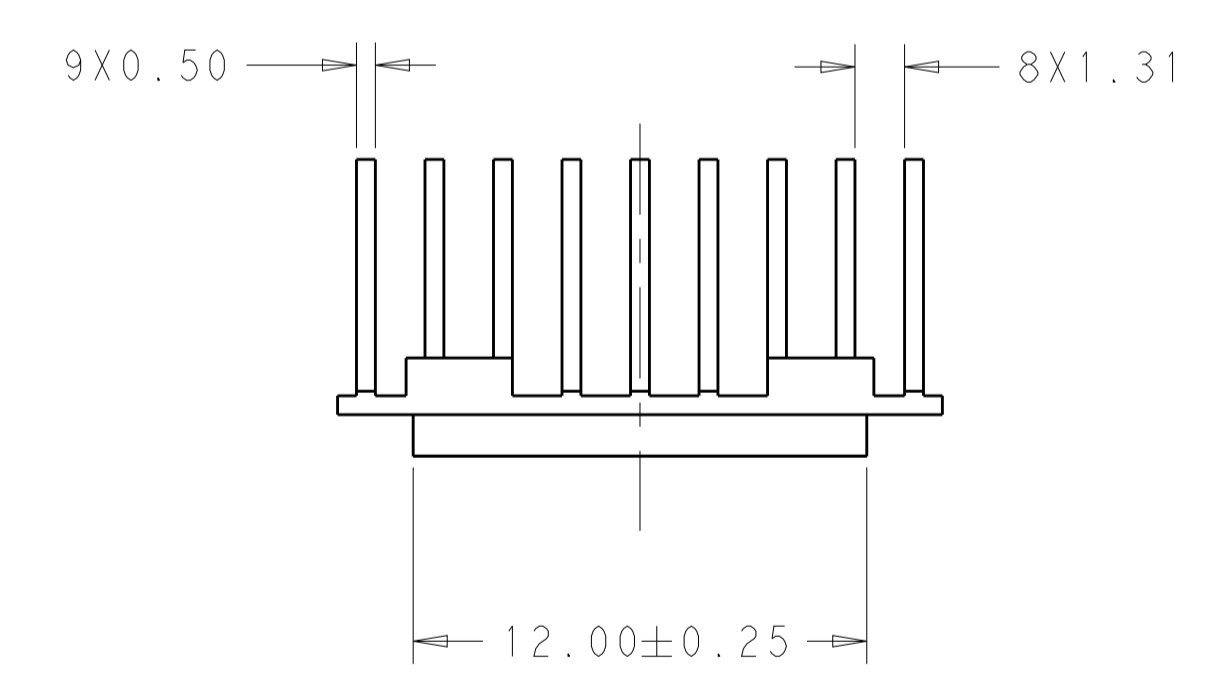
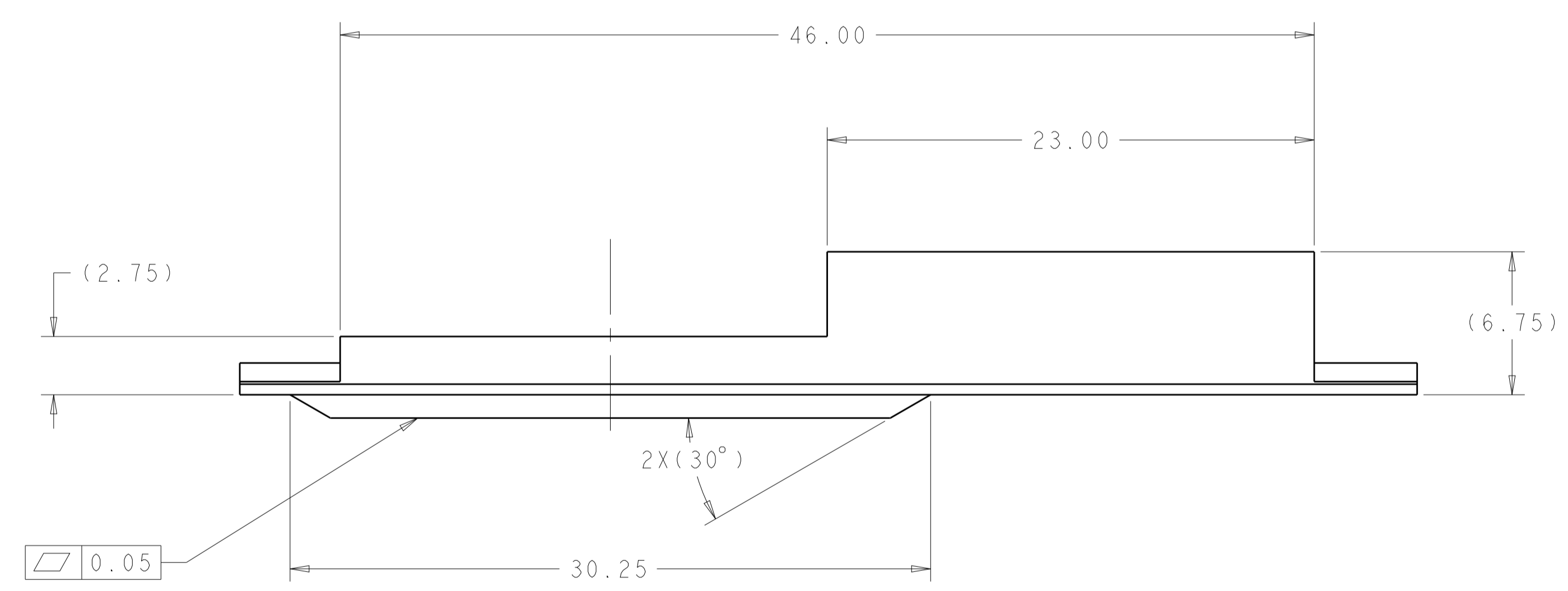

THIS DRAWING IS A CONTROLLED DOCUMENT.		DMN TIM XUE 28JAN2016	TE Connectivity
DIMENSIONS: mm		CHK SEAN HAN 28JAN2016	
TOLERANCES UNLESS OTHERWISE SPECIFIED:		APVD SEAN HAN 28JAN2016	NAME CAGE AND CONNECTOR ASSEMBLY WITH EMI SPRING FINGERS, THRU BEZEL, 2X2 ZQSFP+ STACKED WITH HS
0 PLC ±	1 PLC ±0.25	PRODUCT SPEC	SIZE A1
2 PLC ±0.15	3 PLC ±	APPLICATION SPEC	CAGE CODE 114-60015
4 PLC ±	ANGLES ±	RESTRICTED TO	DRAWING NO A100779
MATERIAL SEE NOTE 1	FINISH SEE NOTE 2	WEIGHT CUSTOMER DRAWING	SCALE 4:1
		REV B	SHEET 4 OF 8

LOC	DIST	REVISIONS			
P	LTN	DESCRIPTION	DATE	DMN	APVD
GP	00	SEE SHEET 1	-	-	-

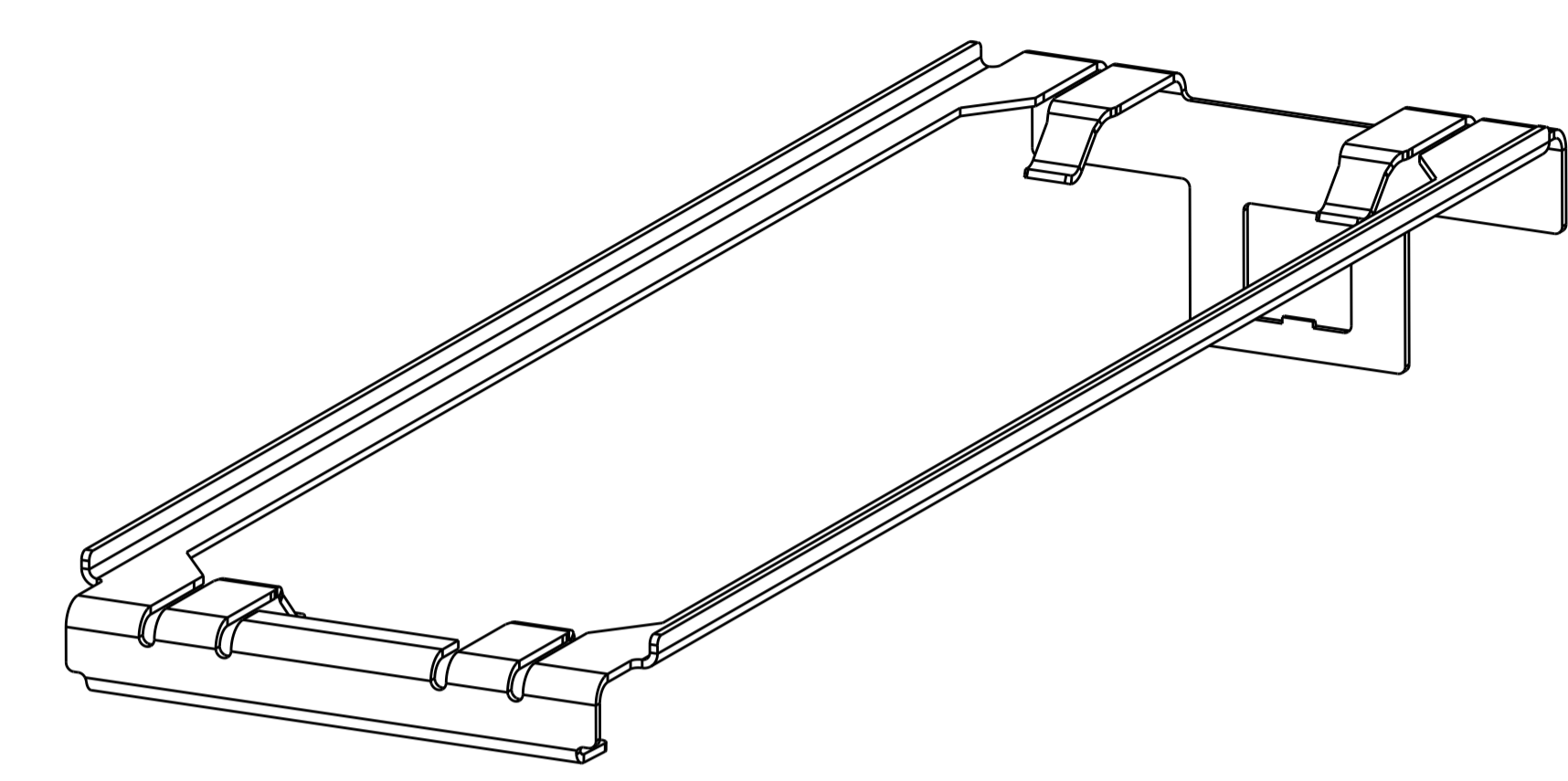
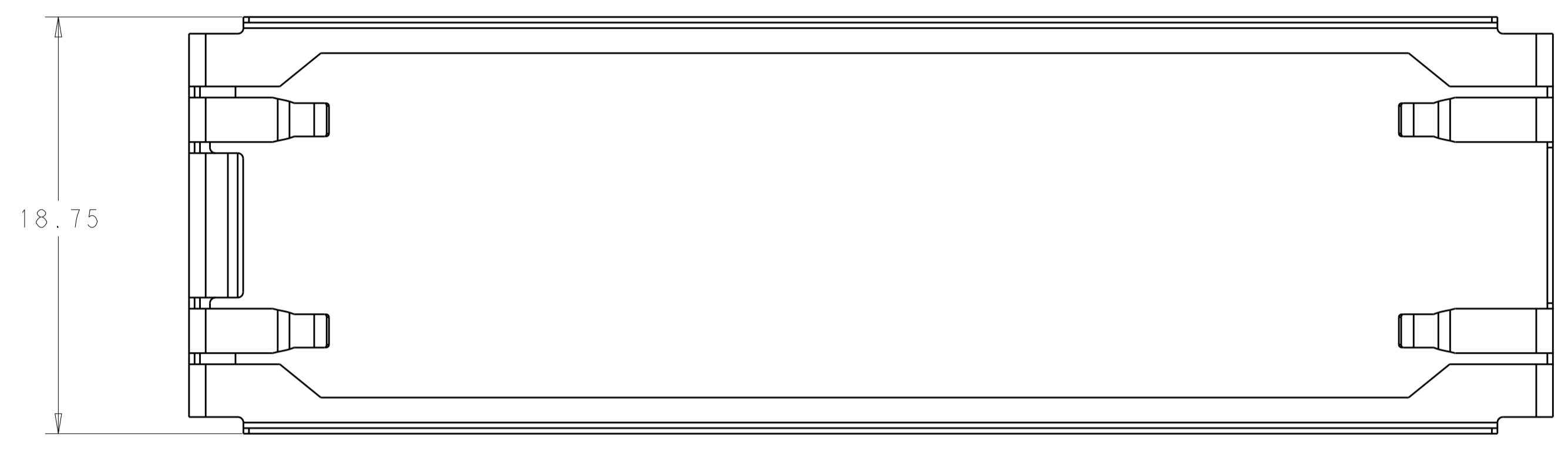

1-2300832-7, HEAT SINK CLIP
 SCALE 5:1

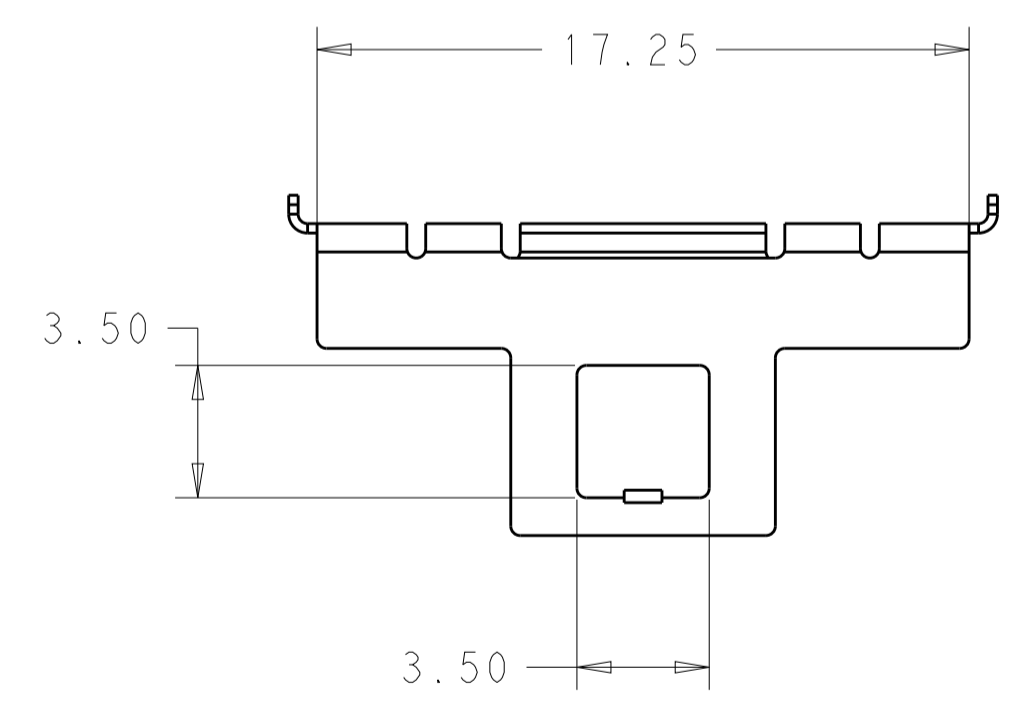
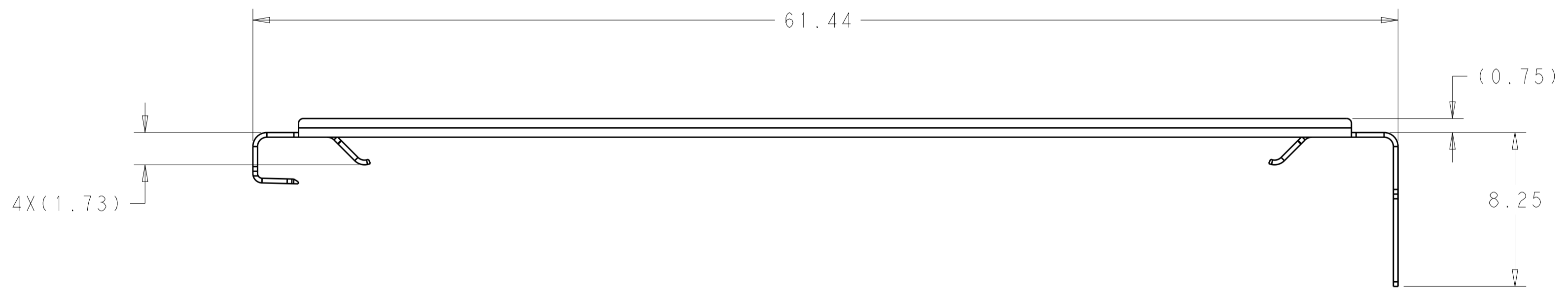

THIS DRAWING IS A CONTROLLED DOCUMENT.		DMN TIM XUE 28JAN2016	
DIMENSIONS: mm		CHK SEAN HAN 28JAN2016	
TOLERANCES UNLESS OTHERWISE SPECIFIED:		APVD SEAN HAN 28JAN2016	NAME CAGE AND CONNECTOR ASSEMBLY WITH EMI SPRING FINGERS, THRU BEZEL, 2X2 ZQSFP+ STACKED WITH HS
0 PLC ±	1 PLC ±0.25	PRODUCT SPEC	SIZE A100779
2 PLC ±0.15	3 PLC ±	APPLICATION SPEC	CAGE CODE C=2299870
4 PLC ±	ANGLES ±	FINISH	RESTRICTED TO
MATERIAL SEE NOTE 1	SEE NOTE 2	WEIGHT CUSTOMER DRAWING	SCALE 4:1 SHEET 5 OF 8 REV B

LOC	DIST	REVISIONS			
P	LTN	DESCRIPTION	DATE	DMN	APVD
GP	00	SEE SHEET 1			

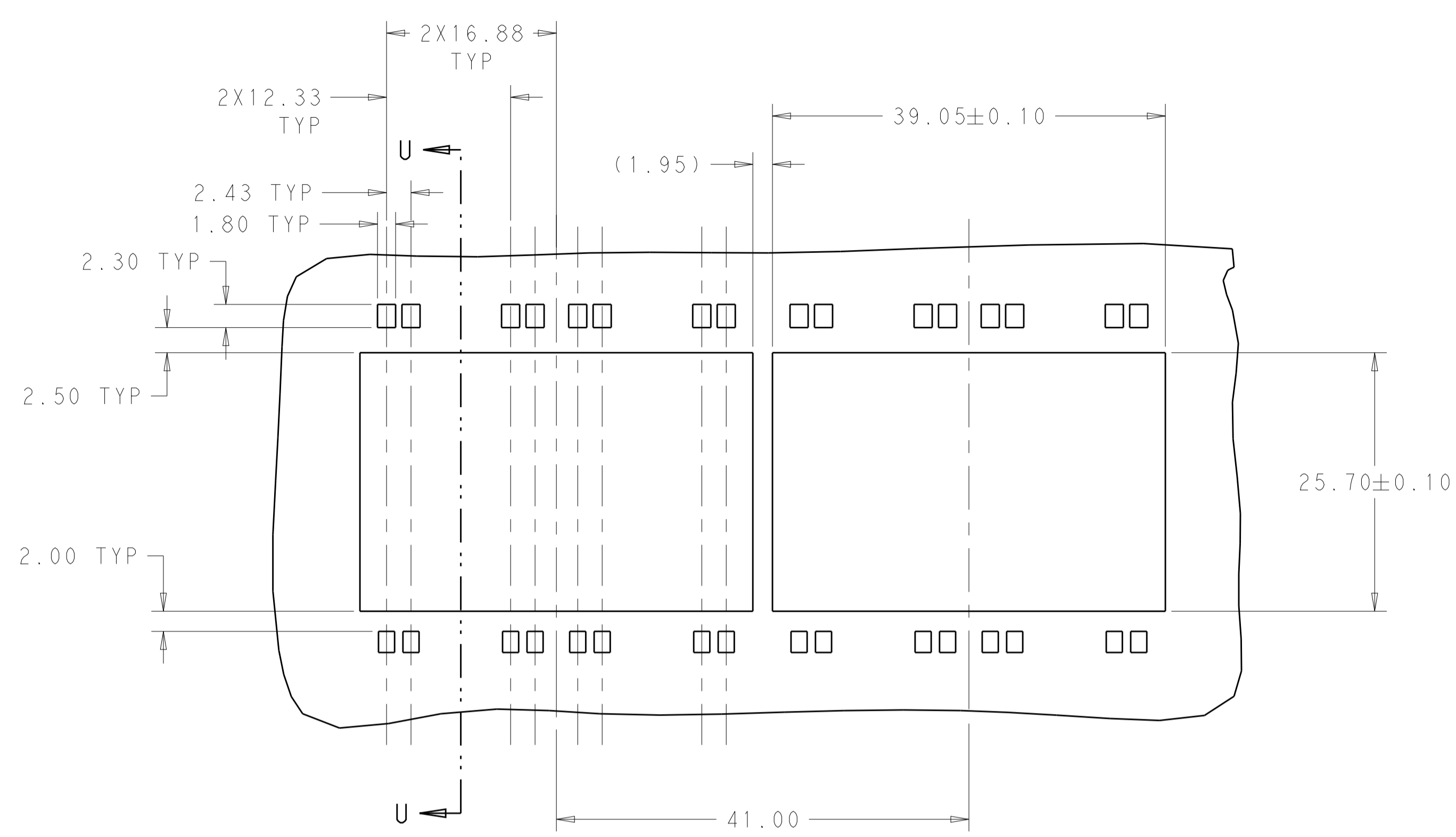

RECOMMENDED PANEL CUTOUT
 AND PC BOARD PANEL POSITION
 SCALE 5:2

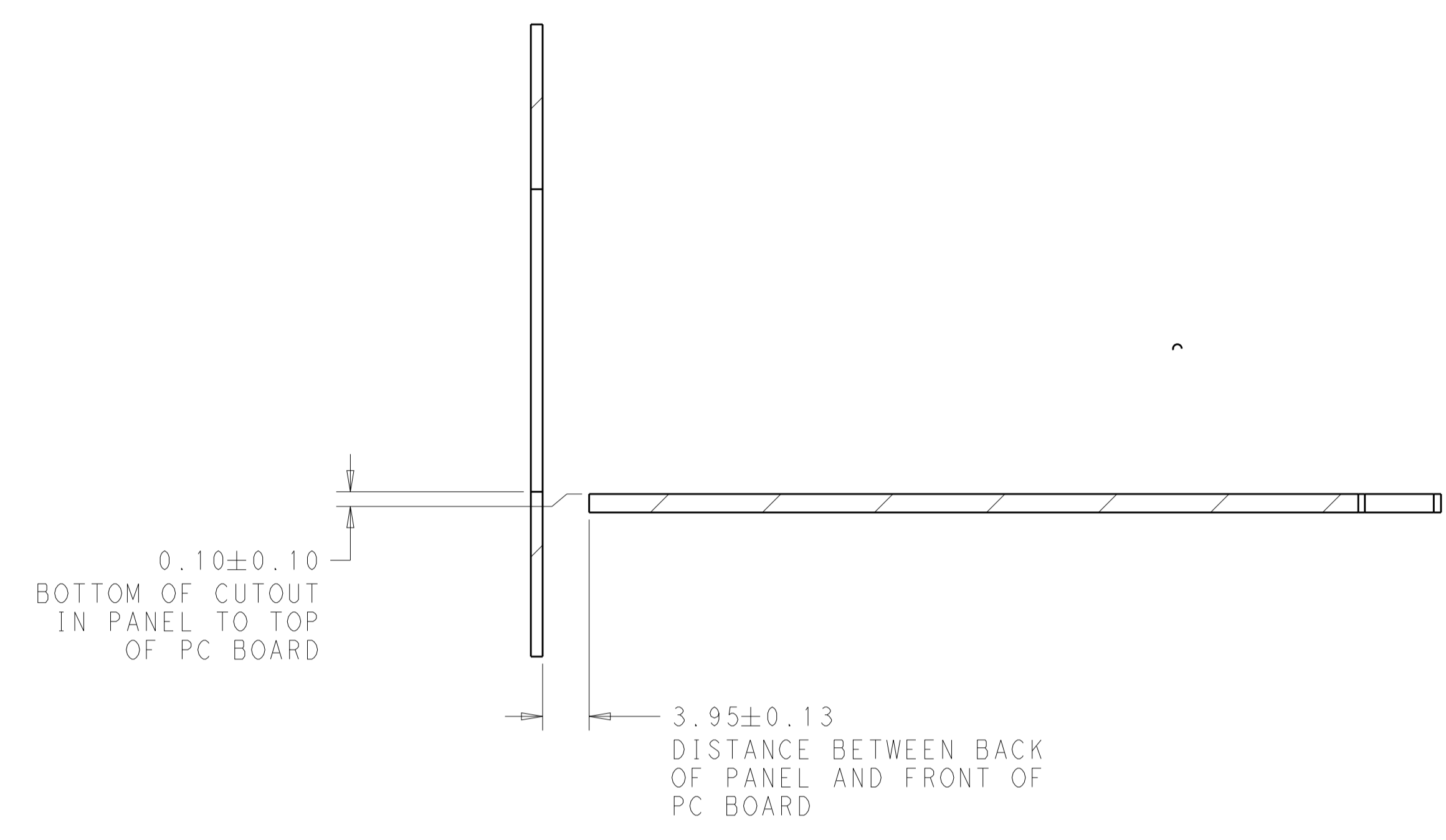

SECTION U-U

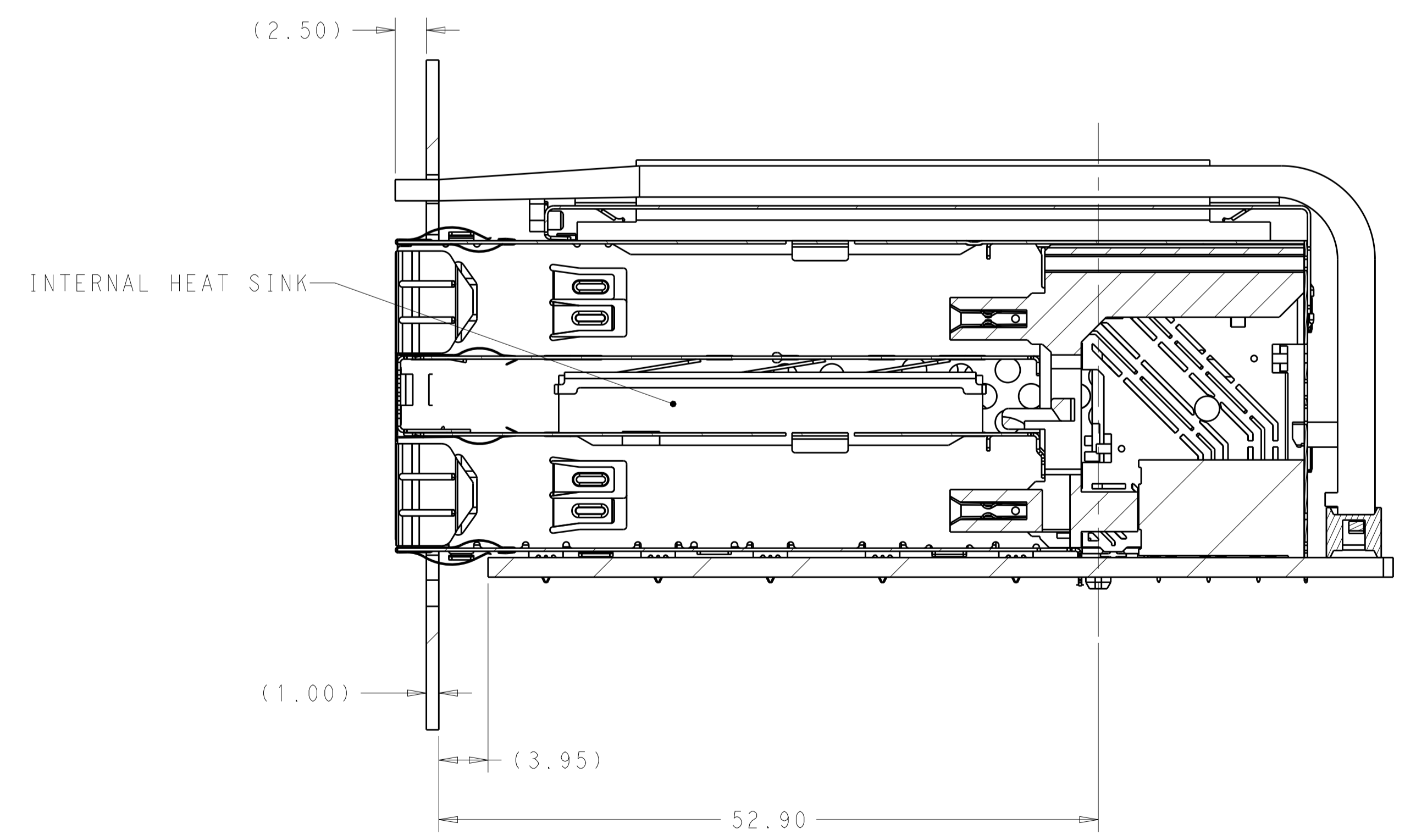

2299870-1 BEZEL LOCATION AS SHOWN
 SECTION V-V
 SCALE 3:1

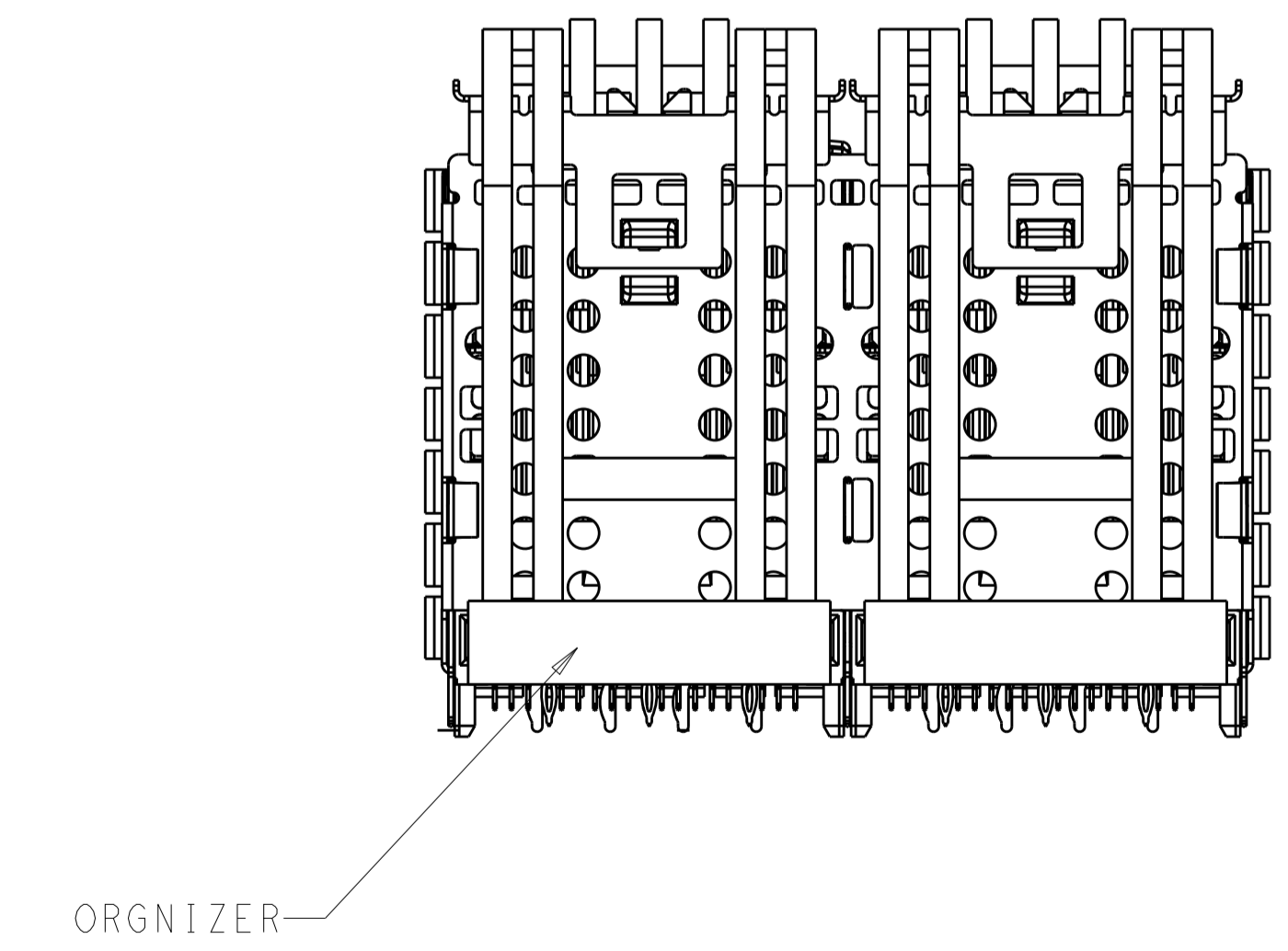

ORGANIZER

THIS DRAWING IS A CONTROLLED DOCUMENT.		DMN TIM XUE 28JAN2016	TE Connectivity	
DIMENSIONS:		CHK SEAN HAN 28JAN2016	NAME	
mm	TOLERANCES UNLESS OTHERWISE SPECIFIED:	APVD SEAN HAN 28JAN2016	CAGE AND CONNECTOR ASSEMBLY WITH EMI SPRING FINGERS, THRU BEZEL, 2X2 ZQSFP+ STACKED WITH HS	
0 PLC ±	1 PLC ±0.25	PRODUCT SPEC	SIZE	CAGE CODE DRAWING NO RESTRICTED TO
2 PLC ±0.15	3 PLC ±	108-60102	A1	00779C=2299870
4 PLC ±	ANGLES ±	APPLICATION SPEC	SCALE	SHEET 6 OF 8 REV B
MATERIAL	FINISH	114-60015	4:1	
SEE NOTE 1	SEE NOTE 2	WEIGHT		
		CUSTOMER DRAWING		

LOC	DIST	REVISIONS			
GP	00	REV	DATE	BY	APPD
		1	SEE SHEET 1		

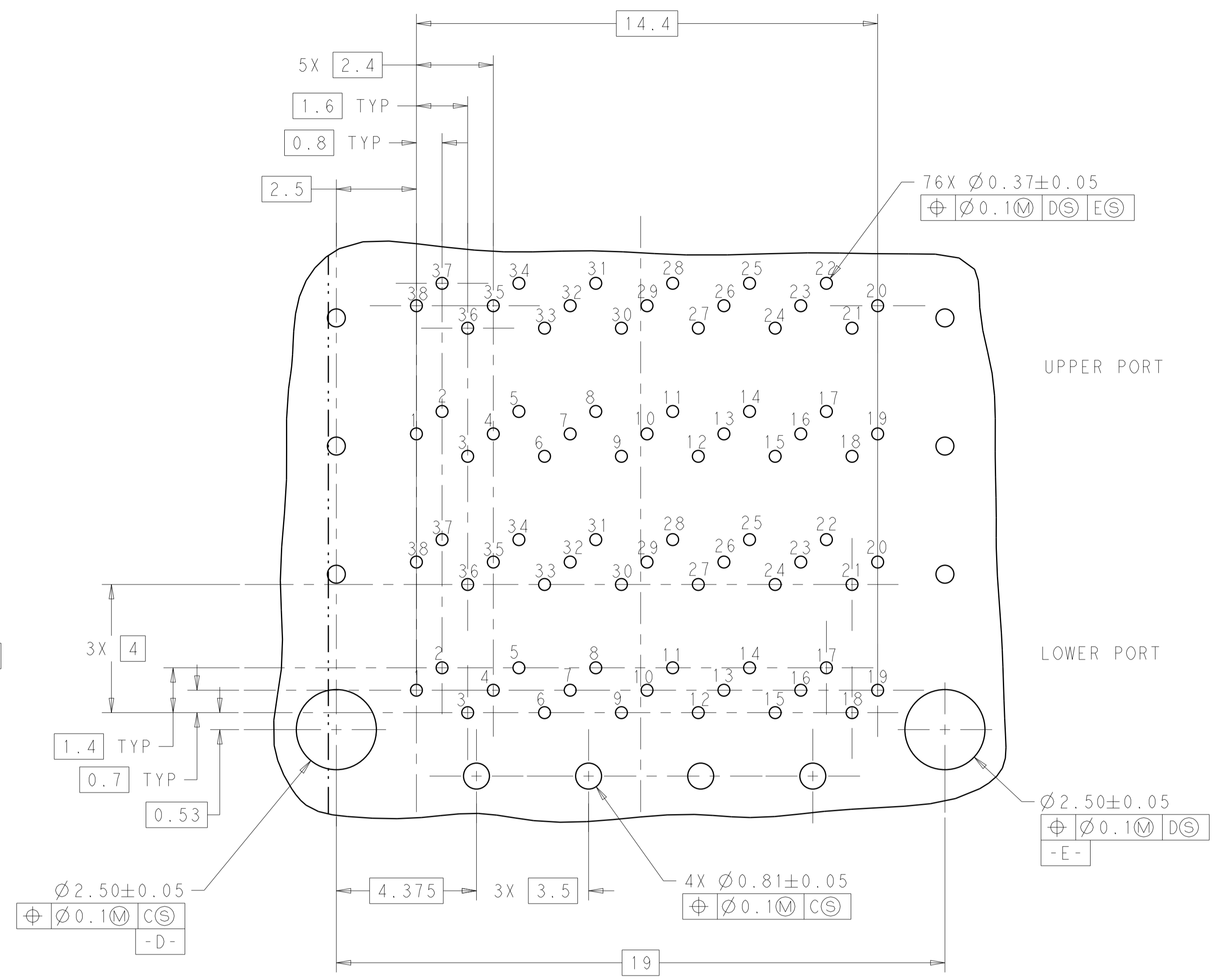
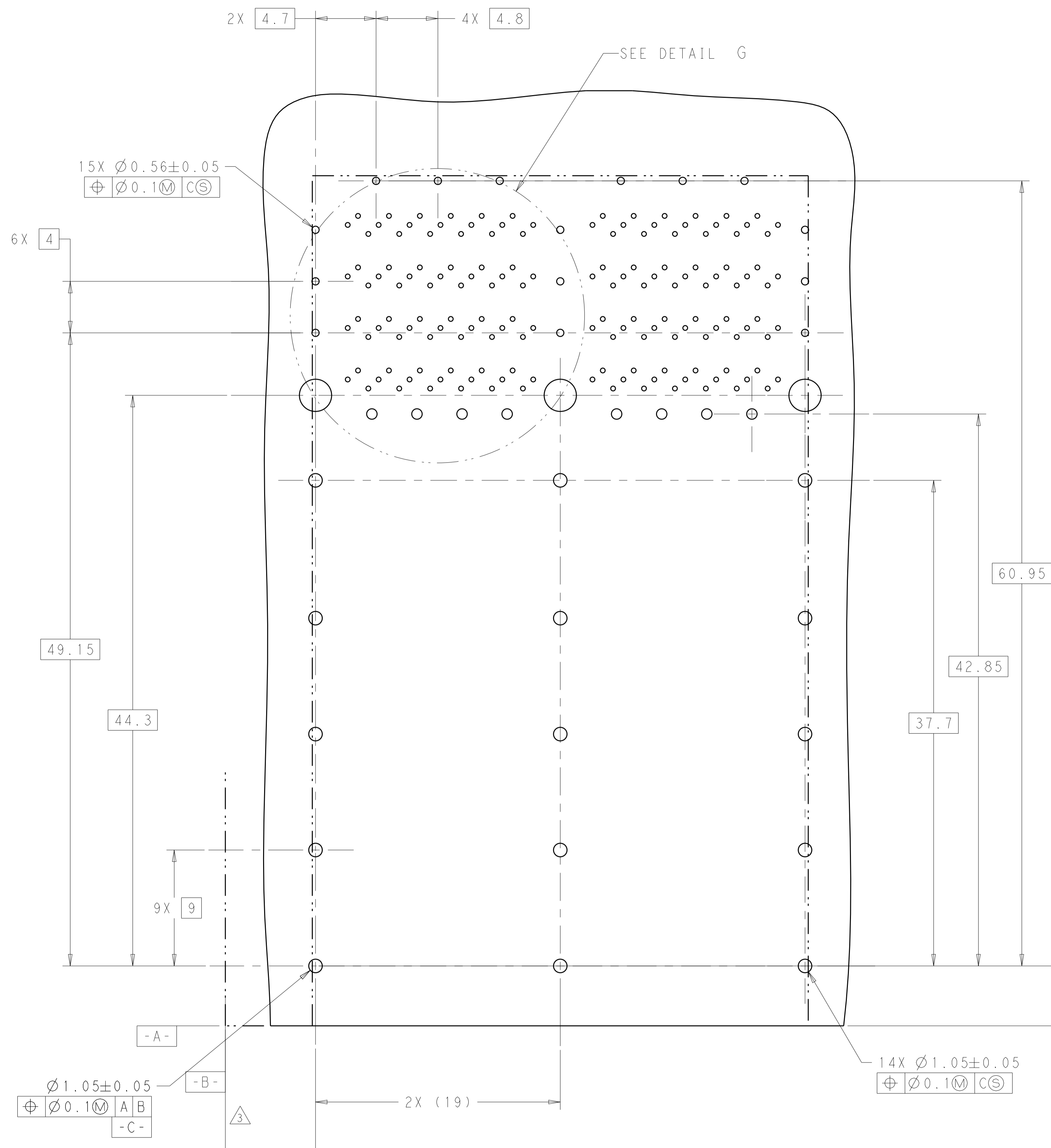

DETAIL G
SCALE 10:1

RECOMMENDED PC BOARD LAYOUT
 COMPONENT SIDE OF BOARD
 (PCB TOLERANCE ±0.05)
 SCALE 5:1

THIS DRAWING IS A CONTROLLED DOCUMENT.		OWN TIM XUE 28JAN2016	TE Connectivity
DIMENSIONS:		CHK SEAN HAN 28JAN2016	
TOLERANCES UNLESS OTHERWISE SPECIFIED:		APVD SEAN HAN 28JAN2016	NAME CAGE AND CONNECTOR ASSEMBLY WITH EMI SPRING FINGERS, THRU BEZEL, 2X2 ZQSFP+ STACKED WITH HS
mm	0 PLC ±	PRODUCT SPEC	SIZE A1
	1 PLC ±0.25	APPLICATION SPEC	CAGE CODE 114-60015
	2 PLC ±0.15	WEIGHT	DRAWING NO C=2299870
	3 PLC ±	RESTRICTED TO	
	4 PLC ±		
MATERIAL	FINISH	CUSTOMER DRAWING	SCALE 4:1
SEE NOTE 1	SEE NOTE 2		SHEET 7 OF 8

LOC	DIST	REV	DATE	BY	APPD
GP	00				

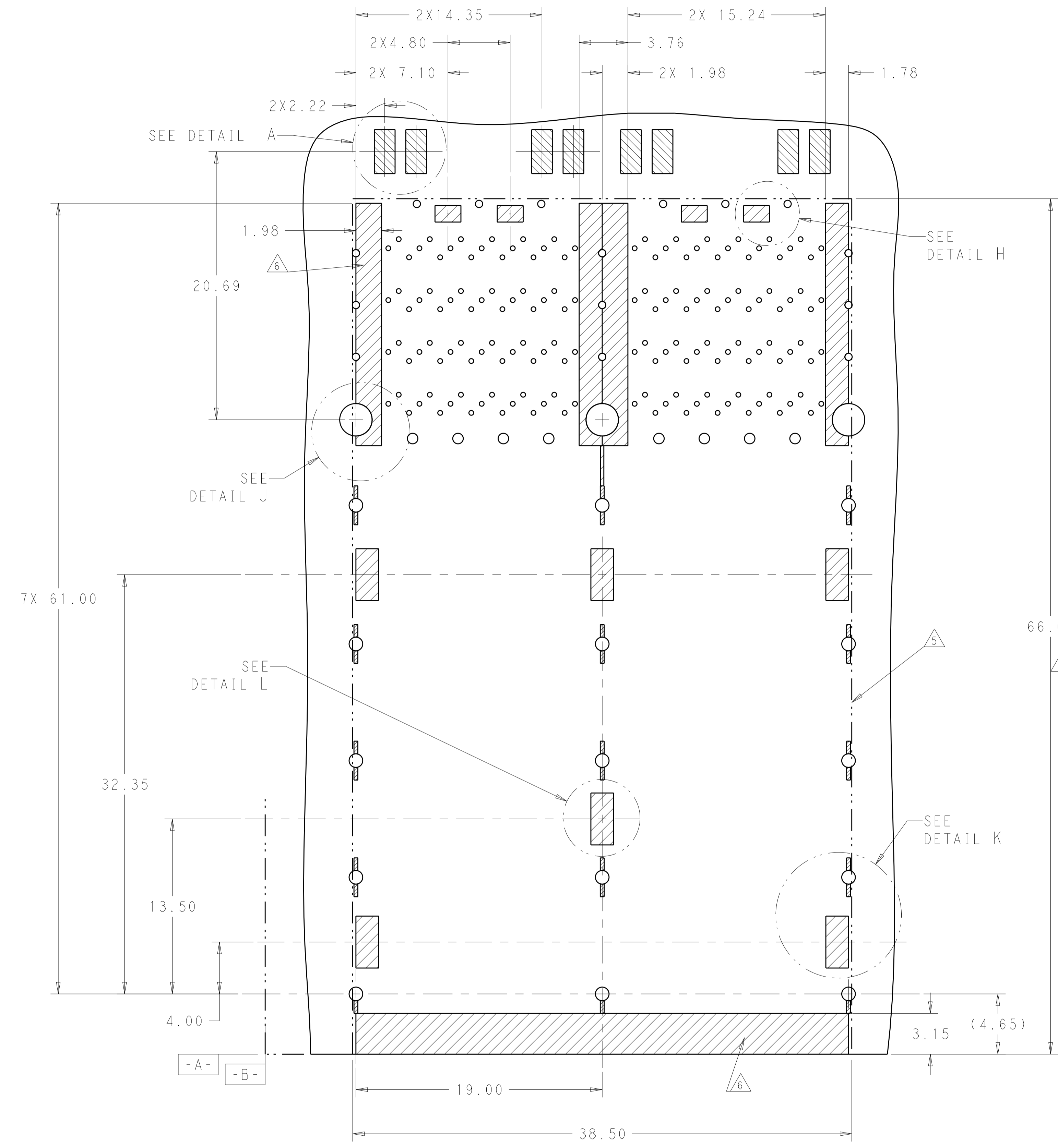

KEEPOUT AREAS
 COMPONENT SIDE OF BOARD
 (PCB TOLERANCE ±0.05)
 SCALE 5:1

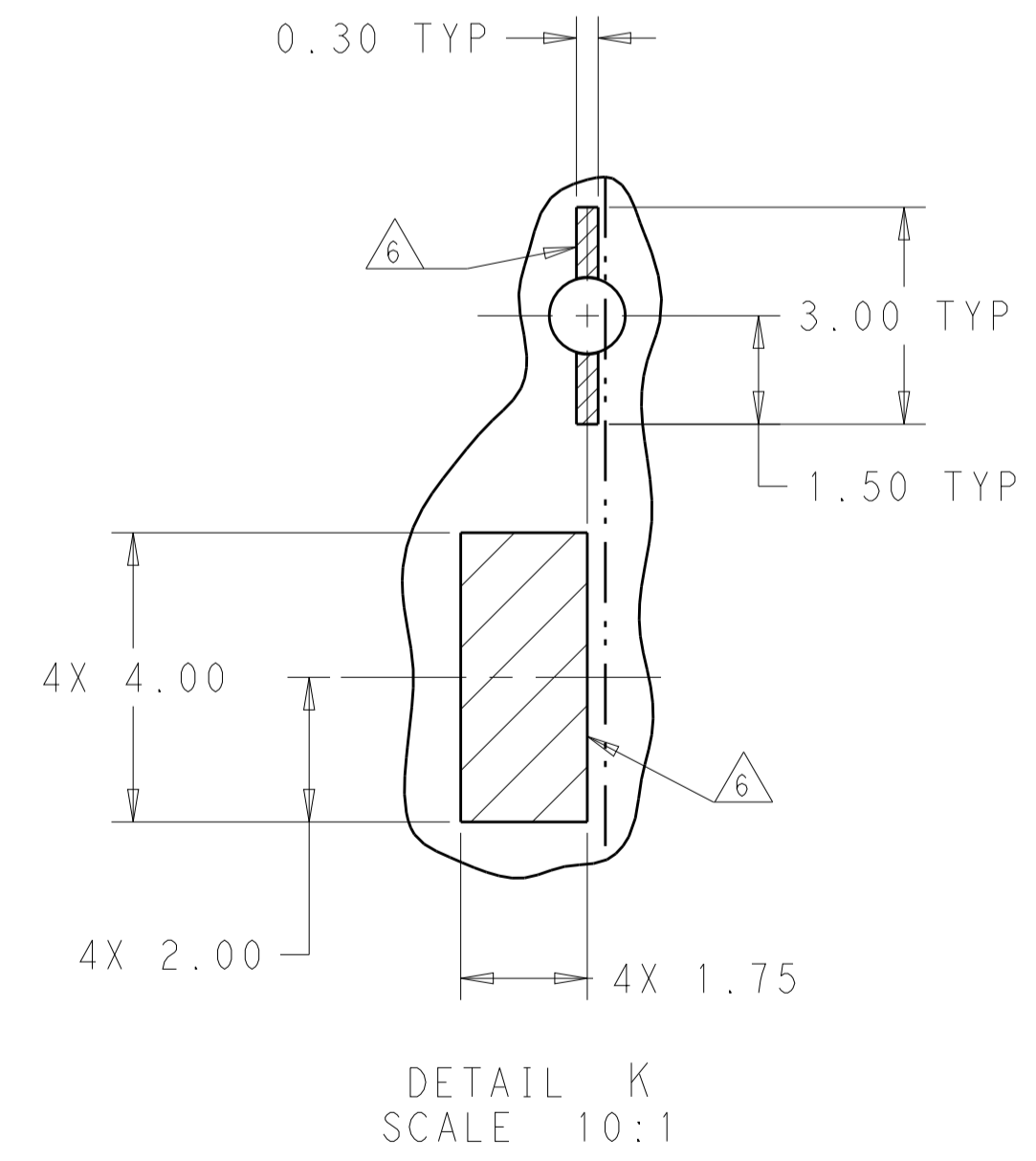
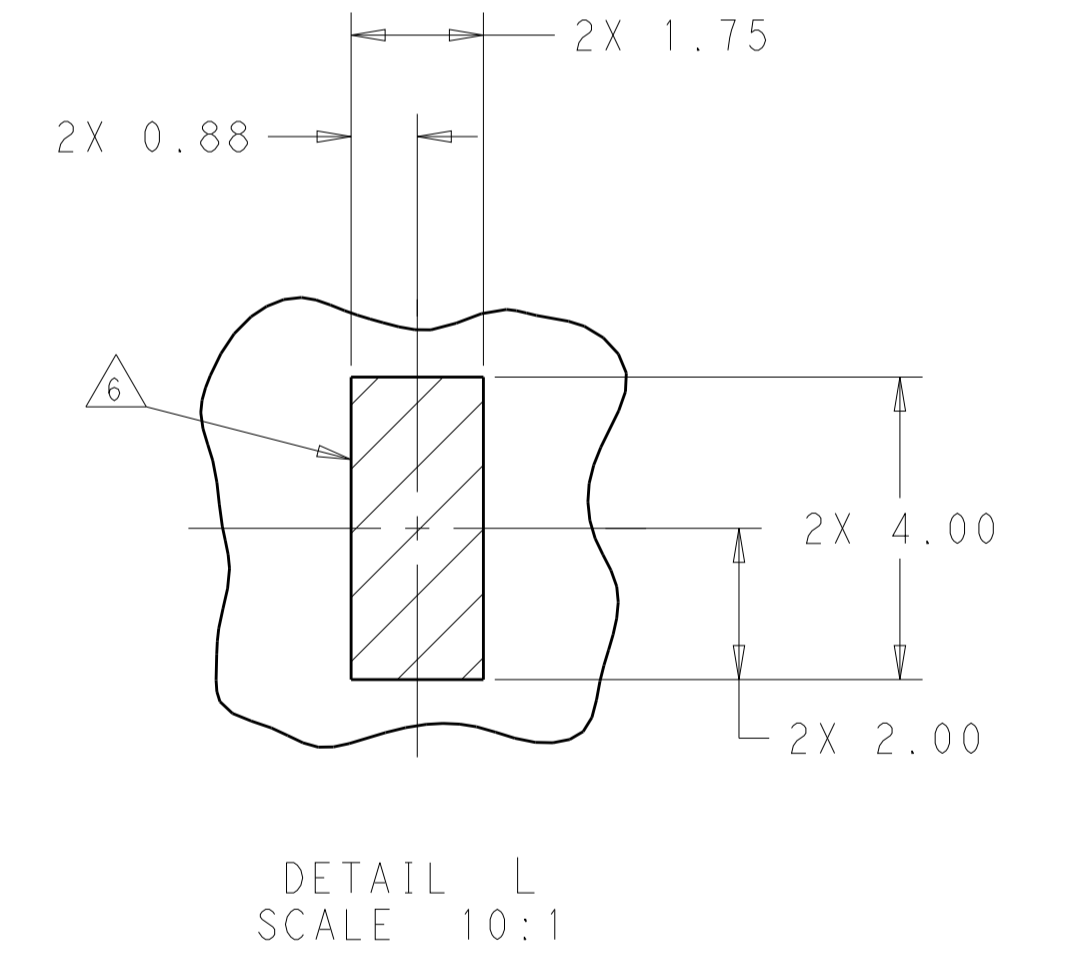
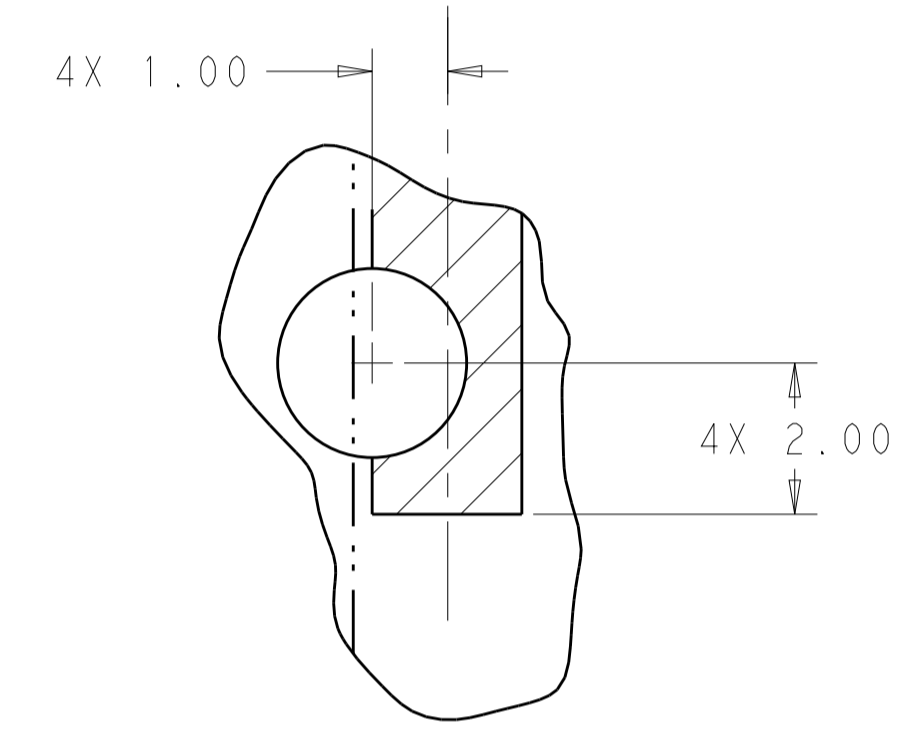
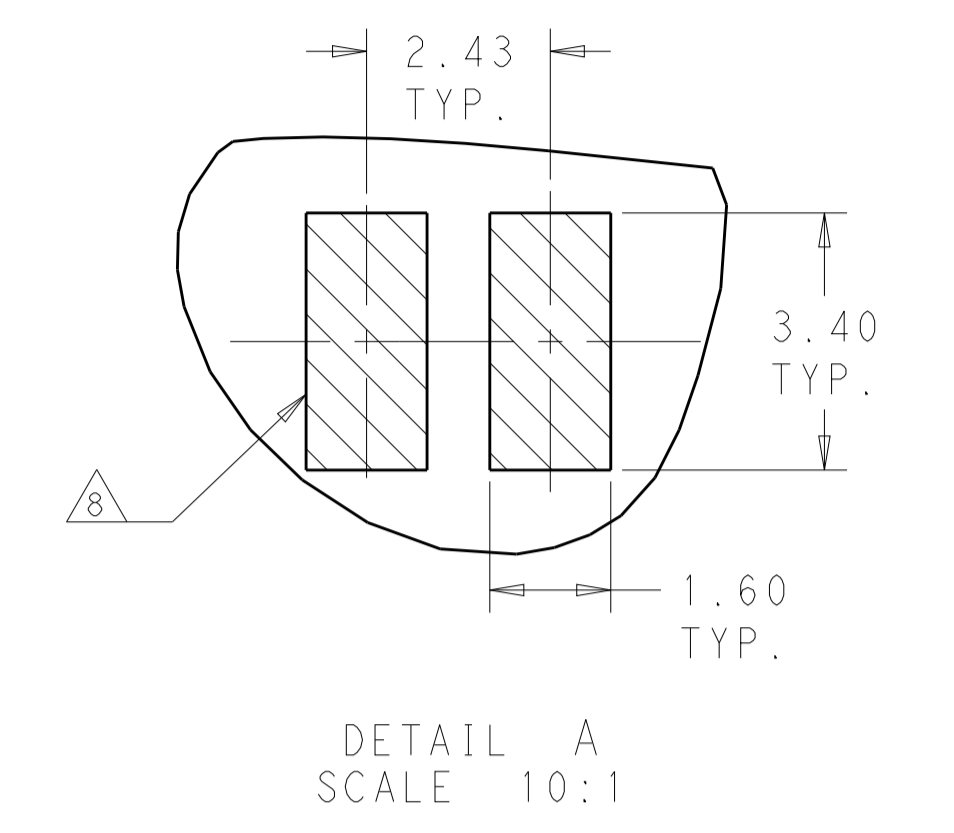
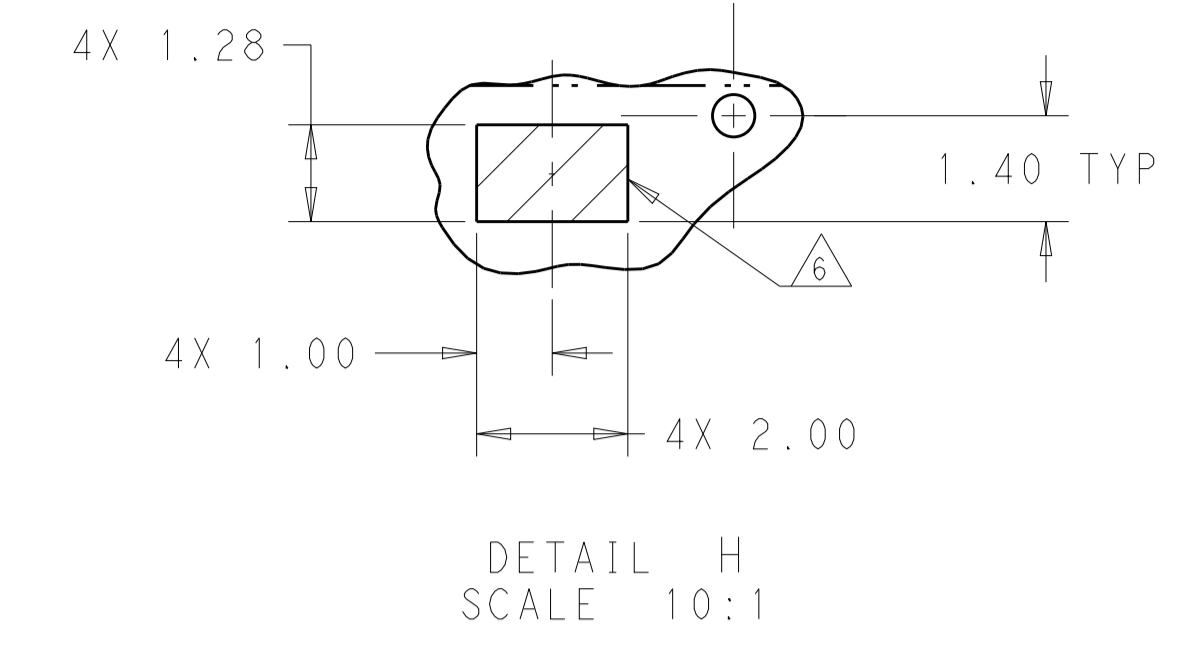

THIS DRAWING IS A CONTROLLED DOCUMENT.		OWN: TIM XUE 28JAN2016	TE Connectivity
DIMENSIONS: mm		CHK: SEAN HAN 28JAN2016	
TOLERANCES UNLESS OTHERWISE SPECIFIED:		APPD: SEAN HAN 28JAN2016	NAME: CAGE AND CONNECTOR ASSEMBLY WITH EMI SPRING FINGERS, THRU BEZEL, 2X2 ZQSF+ STACKED WITH HS
0 PLC ±0.25	1 PLC ±0.15	PRODUCT SPEC: 108-60102	SIZE: 114-60015
2 PLC ±0.15	3 PLC ±0.15	APPLICATION SPEC: 114-60015	RESTRICTED TO: A100779C=2299870
4 PLC ±0.15	5 PLC ±0.15	WEIGHT: -	SCALE: 4:1
ANGLES ±0.15	FINISH: -	CUSTOMER DRAWING	SHEET 8 OF 8
SEE NOTE 1	SEE NOTE 2		REV B



Компания «ЭлектроПласт» предлагает заключение долгосрочных отношений при поставках импортных электронных компонентов на взаимовыгодных условиях!

Наши преимущества:

- Оперативные поставки широкого спектра электронных компонентов отечественного и импортного производства напрямую от производителей и с крупнейших мировых складов;
- Поставка более 17-ти миллионов наименований электронных компонентов;
- Поставка сложных, дефицитных, либо снятых с производства позиций;
- Оперативные сроки поставки под заказ (от 5 рабочих дней);
- Экспресс доставка в любую точку России;
- Техническая поддержка проекта, помощь в подборе аналогов, поставка прототипов;
- Система менеджмента качества сертифицирована по Международному стандарту ISO 9001;
- Лицензия ФСБ на осуществление работ с использованием сведений, составляющих государственную тайну;
- Поставка специализированных компонентов (Xilinx, Altera, Analog Devices, Intersil, Interpoint, Microsemi, Aeroflex, Peregrine, Syfer, Eurofarad, Texas Instrument, Miteq, Cobham, E2V, MA-COM, Hittite, Mini-Circuits, General Dynamics и др.);

Помимо этого, одним из направлений компании «ЭлектроПласт» является направление «Источники питания». Мы предлагаем Вам помощь Конструкторского отдела:

- Подбор оптимального решения, техническое обоснование при выборе компонента;
- Подбор аналогов;
- Консультации по применению компонента;
- Поставка образцов и прототипов;
- Техническая поддержка проекта;
- Защита от снятия компонента с производства.



Как с нами связаться

Телефон: 8 (812) 309 58 32 (многоканальный)

Факс: 8 (812) 320-02-42

Электронная почта: org@eplast1.ru

Адрес: 198099, г. Санкт-Петербург, ул. Калинина, дом 2, корпус 4, литера А.