

Specification

(Reference)

Title: CHIP FUSE; RECTANGULAR TYPE

Style: FMC10, 16

RoHS COMPLIANCE ITEM
Halogen and Antimony Free

Product specification contained in this specification
are subject to change at any time without notice
If you have any questions or a Purchasing Specification for any quality
Agreement is necessary, please contact our sales staff.



釜屋電機株式會社
KAMAYA ELECTRIC CO., LTD.

Issue Dept.: Research & Development Department Hokkaido Research Center

1. Scope

1.1 This specification covers the detail requirements for chip fuses; rectangular type, style of FMC10, 16.

1.2 Applicable documents

- UL248-1-2000 Low-Voltage Fuses-Part1: General Requirements
- UL248-14-2000 Low-Voltage Fuses-Part14: Supplemental Fuses
- CSA C22.2 No.248.1-2000 Low-Voltage Fuses-Part1: General Requirements
- CSA C22.2 No.248.14-2000 Low-Voltage Fuses-Part14: Supplemental Fuses

2. Classification

Type designation shall be the following form.

(Example)

FMC	16	202	AB	TP
1	2	3	4	5

- 1 Chip fuses; rectangular type
- 2 Size Style
- 3 Rated current Example: 202 → 2.0 (A)
- 4 Optional code

Symbol	Optional code
AB	Standard
WB	
WH	

5 Packaging form

3. Safety standard approval

- UL248-1 and UL248-14
- CSA C22.2, No. 248.1-00 and CSA C22.2, No. 248.14-00

The file number to be designated by UL and C-UL shall be as follows: E176847

4. Rating

The ratings shall be in accordance with Table-1.

4.1 Optional code: AB

Table-1(1)

Style	Rated current			Internal resistance value (mΩ max.)	Rated voltage (V)	Breaking capacity (A)	Time / current characteristic	
	Symbol	(A)	Marking symbol				Current	Pre-arcing time
FMC10	501	0.5	F	240	DC24	35	100%	4 h min.
	751	0.75	A	140				
	102	1.0	L	95				
	132	1.25	M	73				
	152	1.5	H	60				
	202	2.0	S	41				
	252	2.5	T	32				
	302	3.0	R	25				
							200%	5 s max.
							300%	0.2 s max.

4.2 Optional code: WB

Table-1(2)

Style	Rated current			Internal resistance value (mΩ max.)	Rated voltage (V)	Breaking capacity (A)	Time / current characteristic	
	Symbol	(A)	Marking symbol				Current	Pre-arcing time
FMC16	501	0.5	F	260	DC32	35	100% 200% 300%	4 h min. 5 s max. 0.2 s max.
	751	0.75	A	140				
	102	1.0	L	110				
	132	1.25	M	80				
	152	1.5	H	65				
	202	2.0	S	45				
	252	2.5	T	32				
	302	3.0	R	26				
	402	4.0	X	18				
	502	5.0	Y	14				

4.3 Optional code: WH

Table-1(3)

Style	Rated current			Internal resistance value (mΩ max.)	Rated voltage (V)	Breaking capacity (A)	Time / current characteristic	
	Symbol	(A)	Marking symbol				Current	Pre-arcing time
FMC10	501	0.5	<u>F</u>	250	DC24	35	100% 200% 300%	4 h min. 5 s max. 0.2 s max.
	751	0.75	<u>A</u>	150				
	102	1.0	<u>L</u>	100				
	132	1.25	<u>M</u>	70				
	152	1.5	<u>H</u>	60				
	202	2.0	<u>S</u>	40				
	252	2.5	<u>T</u>	30				
	302	3.0	<u>R</u>	25				
	322	3.15	<u>U</u>	24				
	402	4.0	<u>X</u>	18				
FMC16	501	0.5	OF	400	DC32	35	100% 200% 300%	4 h min. 5 s max. 0.2 s max.
	631	0.63	OI	300				
	751	0.75	OA	210				
	801	0.8	OK	180				
	102	1.0	OL	115				
	132	1.25	OM	90				
	152	1.5	OH	70				
	162	1.6	ON	60				
	202	2.0	OS	50				
	252	2.5	OT	37				
	302	3.0	OR	28				
	322	3.15	OU	26				
	402	4.0	OX	18				
502	5.0	OY	14					

4.4 Working temperature range: -55 to +125(°C)

5. Packaging form

The standard packaging form shall be in accordance with Table-2.

Table-2

Symbol	Packaging form		Standard packaging quantity / units	Application
B	Bulk (loose package)		1,000 pcs.	FMC10, 16
TH	Paper taping	8mm width, 2mm pitches	10,000 pcs.	FMC10
TP	Paper taping	8mm width, 4mm pitches	5,000 pcs.	FMC16

6. Dimensions

6.1 The resistor shall be of the design and physical dimensions in accordance with Figure-1 and Table-3.

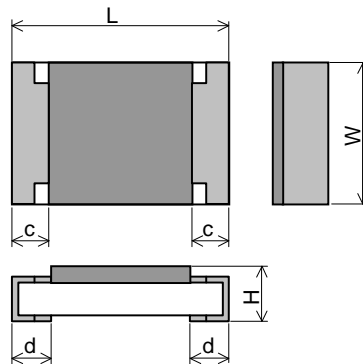

Figure-1

Table-3

Unit : mm

Style	Optional code	L	W	H	c	d
FMC10	WH	1.0±0.05	0.5±0.05	0.35±0.05	0.2±0.10	0.25±0.10
	AB			0.38±0.05		
FMC16	WB,WH	1.6±0.1	0.8 ^{+0.15} _{-0.05}	0.45±0.10	0.3±0.15	0.3±0.1

6.2 Net weight (Reference)

Style	Net weight(mg)
FMC10	0.6
FMC16	2

7. Marking

The Marking symbol of Sub-clause 4.1 shall be marked on over coat side.

(Example)

Style	Optional code	Marking symbol	Content
FMC10	AB	S	FMC10 202 AB
FMC10	WH	<u>S</u>	FMC10 202 WH
FMC16	WB	S	FMC16 202 WB
FMC16	WH	OS	FMC16 202 WH

8. Performance

8.1 Unless otherwise specified, the standard range of atmospheric conditions for tests is as follows;

Ambient temperature: 5 °C to 35 °C, Relative humidity: 45 % to 85 %, Air presser: 86 kPa to 106 kPa

If there is any doubt the results, measurements shall be made within the following:

Ambient temperature: 20 °C ± 2 °C, Relative humidity: 60 % to 70 %, Air presser: 86 kPa to 106 kPa

8.2 The performance shall be satisfied in Table-4.

Table-4(1)

No.	Test items	Condition of test	Performance requirements	
1	Temperature rise	The fuse shall be mounted on the test substrate as shown in Figure-2. Measurement temp.: 10 °C to 30 °C Test current: Rated current The temperature at the hottest point on the surface of the fuse shall be measured after temperature equilibrium has been attained.	75 °C max.	
2	Time / current characteristic	The fuse shall be mounted on the test substrate as shown in Figure-2. Test current shall be applied for continuously.	Current	Pre-arcng time
			100% 200% 300%	4 h min. 5 s. max. 0.2 s max.
3	Terminal bond strength of the face plating	<u>JIS C 60068-2-21 Ue1</u> The fuse shall be mounted on the test substrate as shown in Figure-2. Bending value: 3 mm(Among the fulcrums: 90 mm) Duration: 10 s ± 1 s	Change of internal resistance: ±10% No evidence of mechanical damage.	
4	Resistance to soldering heat	Test by a piece. Temp. of solder bath: 260 °C ± 5 °C Immersion time: 10 s ± 1 s After immersion into solder, leaving the room temp. for 1h or more, and then measure the internal resistance.	Change of internal resistance: ±10% No evidence of appearance damage	
		• Reflow soldering Pre-heating: 150 °C ~ 180 °C, 120 s max. Peak: 260 °C ± 5 °C, 10 s max. Reflow cycle: 2 times After immersion into solder, leaving the room temp. for 1h or more, and then measure the internal resistance.		
5	Solderability	<u>JIS C 60068-2-58</u> Test by a piece Flux: Rosin-Methanol Temp. of solder: bath: 235 °C ± 5 °C Immersion time: 2 s ± 0.5 s	The surface of terminal immersed shall be min. of 95 % covered with a new coating of solder.	
6	Rapid change temperature	<u>JIS C 60068-2-14 Na</u> The fuse shall be mounted on the test substrate as shown in Figure-2. Lower temperature: -55 °C Upper temperature: +125 °C Duration of exposure at each temperature: 30 min. Number of cycles: 5 cycles	Change of internal resistance: ±10% No evidence of appearance damage	

9. Test substrate

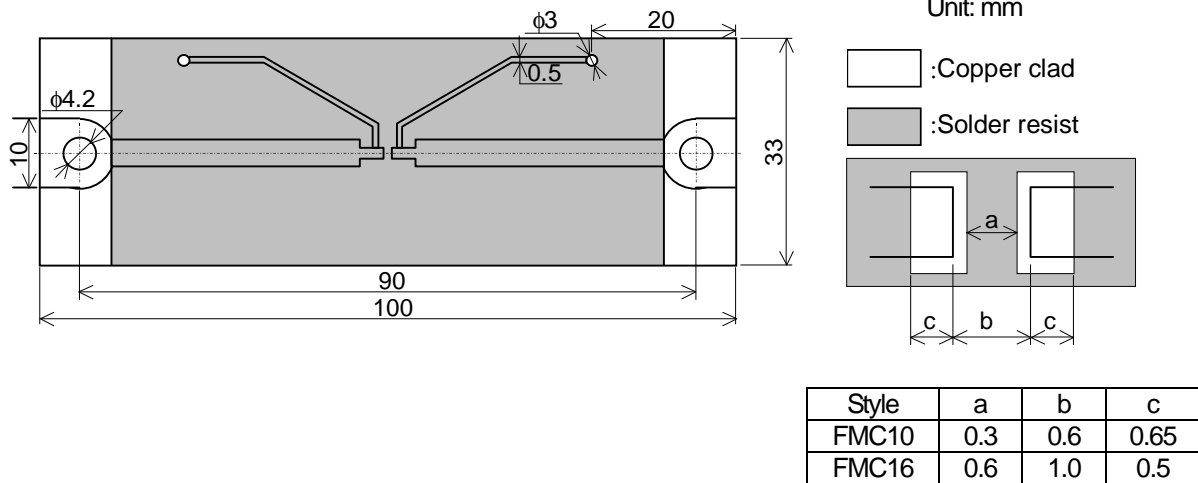

Figure-2 FMC TEST SUBSTRATE

Remark 1). Material: Epoxide woven glass
Thickness: 1.6mm Thickness of copper clad: 0.035mm

10. Taping

10.1 Applicable documents JIS C 0806-3: 1999, EIAJ ET-7200B: 2003

10.2 Taping dimensions

10.2.1 Paper taping (8mm width, 2mm pitches)

Taping dimensions shall be in accordance with Figure-3 and Table-5.

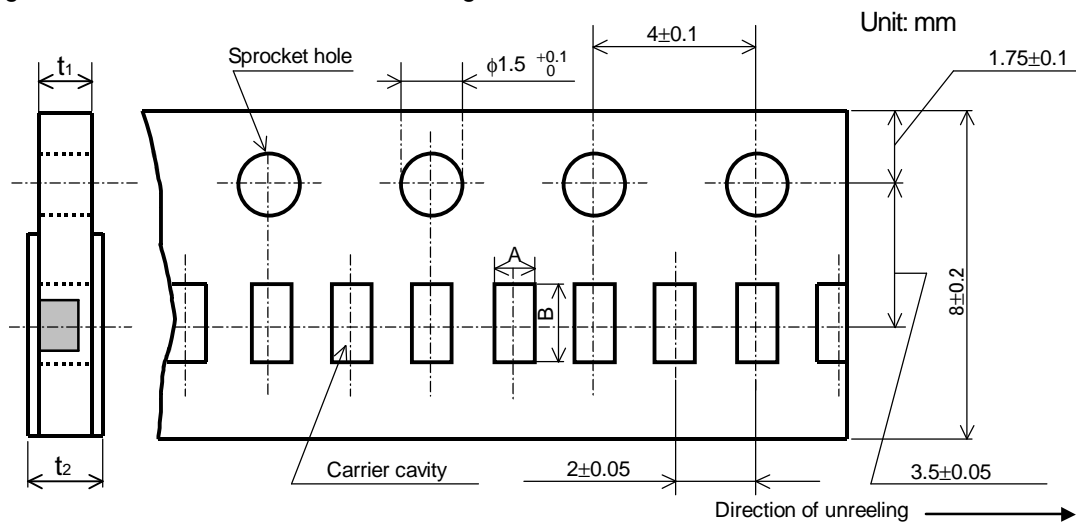

Figure-3

Table-5

Unit: mm

Style	A	B	t ₁	t ₂
FMC10	0.65 ^{+0.05} / _{-0.10}	1.15 ^{+0.05} / _{-0.10}	0.4 ± 0.05	0.5max.

10.2.2 Paper taping (8mm width, 4mm pitches)

Taping dimensions shall be in accordance with Figure-4 and Table-6.

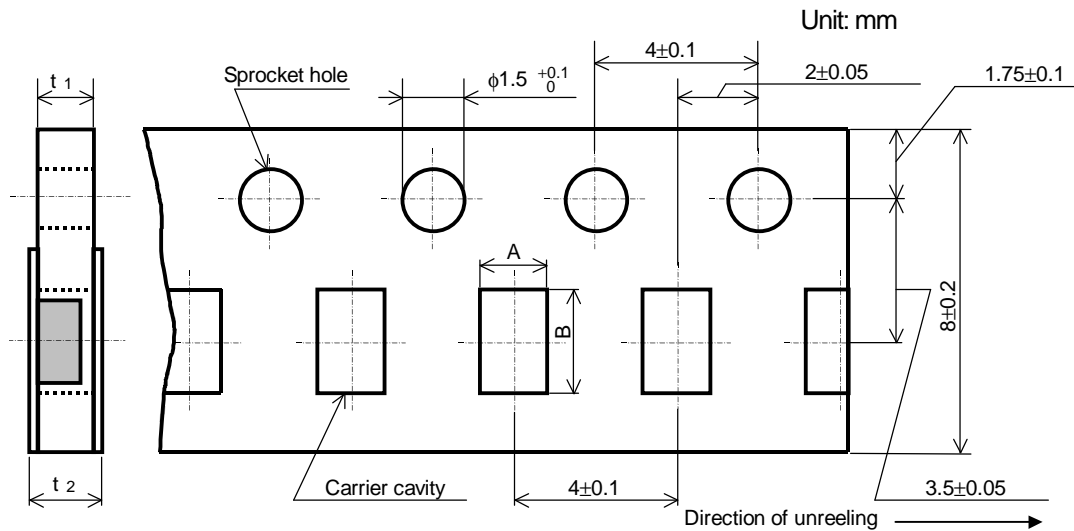

Figure-4

Table-6

Unit : mm

Style	A	B	t ₁	t ₂
FMC16	1.15±0.15	1.9±0.2	0.6±0.1	0.8 max.

- 1). The cover tapes shall not cover the sprocket holes.
- 2). Tapes in adjacent layers shall not stick together in the packing.
- 3). Components shall not stick to the carrier tape or to the cover tape.
- 4). Pitch tolerance over any 10 pitches ±0.2mm.
- 5). The peel strength of the top cover tape shall be within 0.1N to 0.5N on the test method as shown in the following Figure-5.
- 6). When the tape is bent with the minimum radius for 25 mm, the tape shall not be damaged and the components shall maintain their position and orientation in the tape.
- 7). In no case shall there be two or more consecutive components missing.
The maximum number of missing components shall be one or 0.1%, whichever is greater.
- 8). The fuses shall be faced to upward at the over coating side in the carrier cavity.

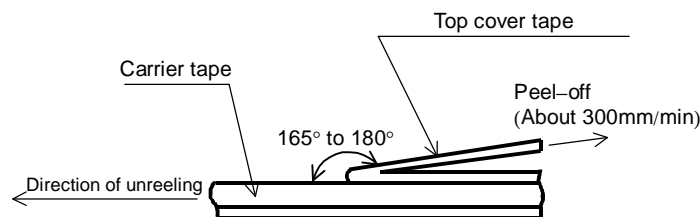

Figure-5

10.3 Reel dimension

Reel dimensions shall be in accordance with the following Figure-6 and Table-7.

Plastic reel (Based on EIAJ ET-7200B)

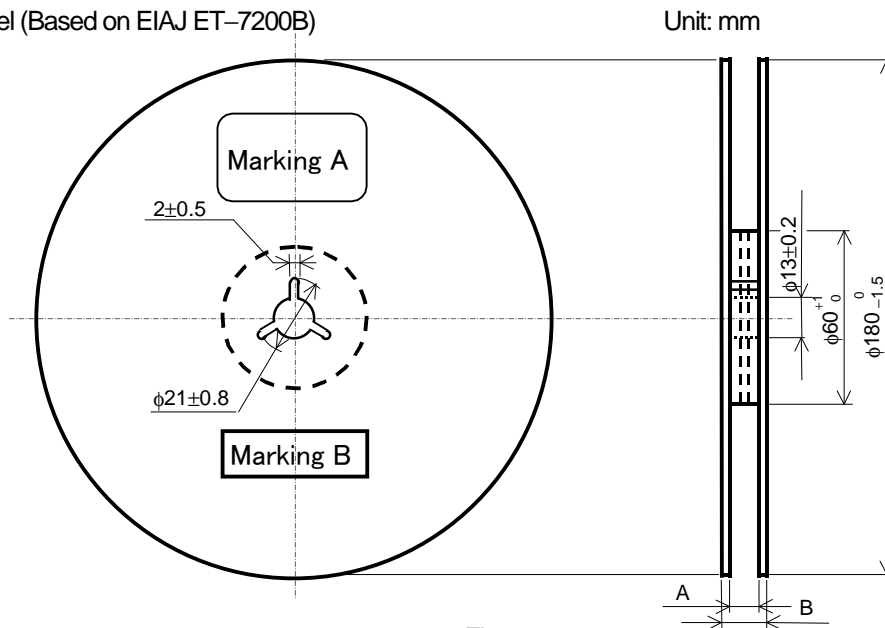

Figure-6

Table-7

Unit: mm			
Style	A	B	Note
FMC10, 16	9 ^{+1.0} ₀	11.4±1.0	Injection molding
		13±1.0	Vacuum forming

Note: Marking label shall be marked on a place of Marking A or two place of marking A and B.

10.4 Leader and trailer tape.

Example)

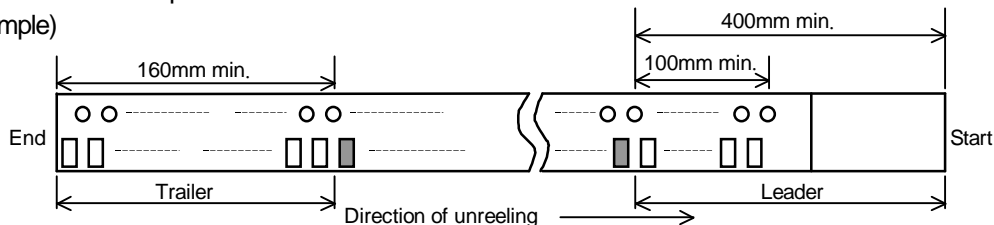

Figure-7

11. Marking on package

The label of a minimum package shall be legibly marked with follows.

11.1 Marking A

- (1) Classification (Style, Rated current, Optional code, Packaging form)
- (2) Quantity
- (3) Lot number
- (4) Manufacturer's name or trade mark
- (5) UL and /or C-UL recognized component mark
- (6) Others

11.2 Marking B (KAMAYA Control label)

12. Recommended Derating for Rated Current

This fuse will recommend use by the current reduction value according to the following derating curve.

• Nominal Derating

Nominal Derating \leq 75% of Rated Current

*FMC10 Optional code: WH, Rated current \geq 3.15A : Nominal Derating \leq 70% of Rated Current

• Temperature Derating

Please refer to the following graph regarding the current derating value for ambient temperature.

Ex.) If FMC16 202WH (Rated Current 2.0A) is used under ambient temperature 70°C,

Kamaya recommends, less than the current value derated as below,

$$\text{Rated Current} : 2.0\text{A} \times (\text{Nominal Derating} : 75\% \times \text{Temperature Derating} : 80\%) = 1.2\text{A}$$

Derating curve

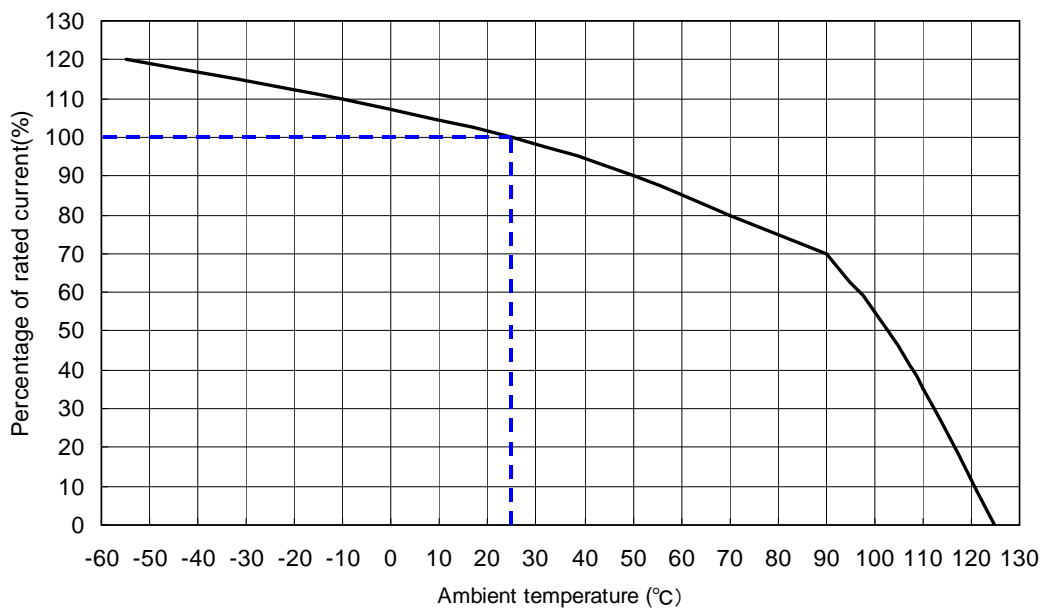

Mouser Electronics

Authorized Distributor

Click to View Pricing, Inventory, Delivery & Lifecycle Information:

[Kamaya:](#)

[FMC10102ABTH](#)



Компания «ЭлектроПласт» предлагает заключение долгосрочных отношений при поставках импортных электронных компонентов на взаимовыгодных условиях!

Наши преимущества:

- Оперативные поставки широкого спектра электронных компонентов отечественного и импортного производства напрямую от производителей и с крупнейших мировых складов;
- Поставка более 17-ти миллионов наименований электронных компонентов;
- Поставка сложных, дефицитных, либо снятых с производства позиций;
- Оперативные сроки поставки под заказ (от 5 рабочих дней);
- Экспресс доставка в любую точку России;
- Техническая поддержка проекта, помощь в подборе аналогов, поставка прототипов;
- Система менеджмента качества сертифицирована по Международному стандарту ISO 9001;
- Лицензия ФСБ на осуществление работ с использованием сведений, составляющих государственную тайну;
- Поставка специализированных компонентов (Xilinx, Altera, Analog Devices, Intersil, Interpoint, Microsemi, Aeroflex, Peregrine, Syfer, Eurofarad, Texas Instrument, Miteq, Cobham, E2V, MA-COM, Hittite, Mini-Circuits, General Dynamics и др.);

Помимо этого, одним из направлений компании «ЭлектроПласт» является направление «Источники питания». Мы предлагаем Вам помощь Конструкторского отдела:

- Подбор оптимального решения, техническое обоснование при выборе компонента;
- Подбор аналогов;
- Консультации по применению компонента;
- Поставка образцов и прототипов;
- Техническая поддержка проекта;
- Защита от снятия компонента с производства.



Как с нами связаться

Телефон: 8 (812) 309 58 32 (многоканальный)

Факс: 8 (812) 320-02-42

Электронная почта: org@eplast1.ru

Адрес: 198099, г. Санкт-Петербург, ул. Калинина, дом 2, корпус 4, литера А.