



SY87700AL

Low-Power, 3.3V, 32Mbps to 208Mbps
AnyRate[®] Clock and Data Recovery

General Description

The SY87700AL is a complete clock recovery and data retiming integrated circuit for data rates from 32Mbps up to 208Mbps NRZ. The device is ideally suited for SONET/SDH/ATM applications and other high-speed data transmission systems.

Clock recovery and data retiming is performed by synchronizing the on-chip VCO directly to the incoming data stream. The VCO center frequency is controlled by the reference clock frequency and the selected divide ratio. On-chip clock generation is performed through the use of a frequency multiplier PLL with a byte rate source as reference.

The SY87700AL also includes a link fault detection circuit.

Data sheets and support documentation can be found on Micrel's web site at: www.micrel.com.



AnyRate[®]

Features

- 3.3V power supply
- SONET/SDH/ATM compatible
- Clock and data recovery from 32Mbps up to 208Mbps NRZ data stream; clock generation from 32Mbps to 208Mbps
- Two on-chip PLLs: one for clock generation and another for clock recovery
- Selectable reference frequencies
- Differential PECL high-speed serial I/O
- Line receiver input: no external buffering needed
- Link fault indication
- 100K ECL-compatible I/O
- Industrial temperature range (-40°C to +85°C)
- Low power: fully compatible with Micrel's SY87700V, but with 30% less power
- Available in 32-pin EPAD-TQFP and 28-pin EPAD SOIC packages, (28-pin SOIC is available, but NOT recommended for new designs.)

Applications

- SONET/SDH/ATM OC-1 and OC-3
- Fast Ethernet, SMPTE 259
- Proprietary architecture up to 208Mbps

AnyRate is a registered trademark of Micrel, Inc.

Micrel Inc. • 2180 Fortune Drive • San Jose, CA 95131 • USA • tel +1 (408) 944-0800 • fax + 1 (408) 474-1000 • <http://www.micrel.com>

August 2009

M9999-082009-D
hbwhelp@micrel.com or (408) 955-1690

Ordering Information⁽¹⁾

Part Number	Package Type	Operating Range	Package Marking	Lead Finish
SY87700ALZG ⁽²⁾	Z28-1	Industrial	SY87700ALZG with Pb-Free bar-line indicator	NiPdAu Pb-Free
SY87700ALHG ⁽²⁾	H32-1	Industrial	SY87700ALHG with Pb-Free bar-line indicator	NiPdAu Pb-Free

Notes:

1. Contact factory for die availability. Dice are guaranteed at $T_A = 25^\circ\text{C}$, DC Electricals only.
2. Pb-Free package is recommended for new designs.

Pin Configuration

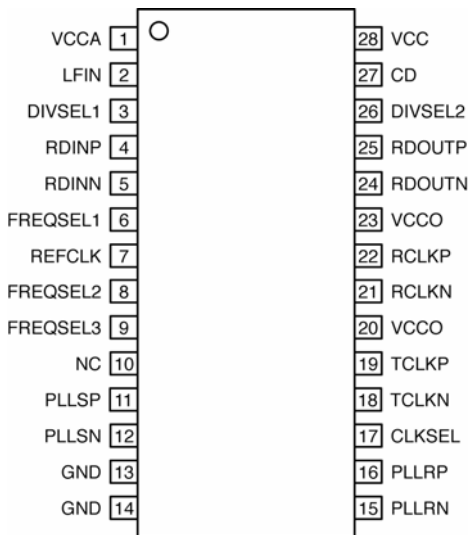

28-Pin SOIC (Z28-1)

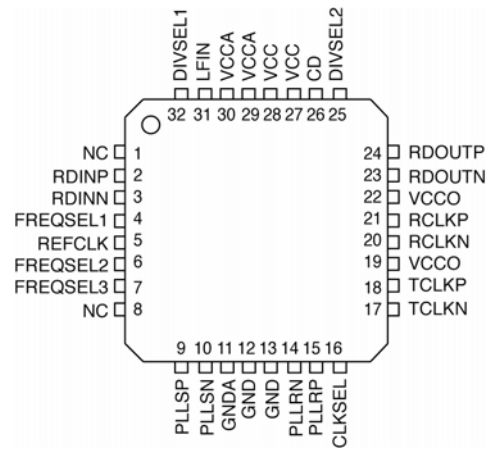

32-Pin EPAD-TQFP (H32-1)

Pin Description

Inputs

Pin Number (28-SOIC)	Pin Number (32-TQFP)	Pin Name	Pin Name
4, 5	2, 3	RDINP, RDINN	Serial Data Input. Differential PECL: These built-in line receiver inputs are connected to the differential receive serial data stream. An internal receive PLL recovers the embedded clock (RCLK) and data (RDOU) information. The incoming data rate can be within one of eight frequency ranges depending on the state of the FREQSEL pins. See "Frequency Selection" Table.
7	5	REFCLK	Reference Clock. TTL Input: This input is used as the reference for the internal frequency synthesizer and the "training" frequency for the receiver PLL to keep it centered in the absence of data coming in on the RDIN inputs
27	26	CD	Carrier Detect. PECL Input: This input controls the recovery function of the Receive PLL and can be driven by the carrier detect output of optical modules or from external transition detection circuitry. When this input is HIGH the input data stream (RDIN) is recovered normally by the Receive PLL. When this input is LOW the data on the inputs RDIN will be internally forced to a constant LOW, the data outputs RDOU will remain LOW, the Link Fault Indicator output LFIN forced LOW and the clock recovery PLL forced to lock onto the clock frequency generated from REFCLK.
6 8 9	4 6 7	FREQSEL1 FREQSEL2 FREQSEL3	Frequency Select. TTL Inputs: These inputs select the output clock frequency range as shown in the "Frequency Selection" Table.
3 26	32 25	DIVSEL1 DIVSEL2	Divider Select. TTL Inputs: These inputs select the ratio between the output clock frequency (RCLK/TCLK) and the REFCLK input frequency as shown in the "Reference Frequency Selection" Table.
17	16	CLKSEL	Clock Select. TTL Input: This input is used to select either the recovered clock of the receiver PLL (CLKSEL = HIGH) or the clock of the frequency synthesizer (CLKSEL = LOW) to the TCLK outputs.

Outputs

2	31	LFIN	Link Fault Indicator. TTL Output: This output indicates the status of the input data stream RDIN. Active HIGH signal is indicating when the internal clock recovery PLL has locked onto the incoming data stream. LFIN will go HIGH if CD is HIGH and RDIN is within the frequency range of the Receive PLL (1000ppm). LFIN is an asynchronous output.
25 24	24 23	RDOU TP RDOU TN	Receive Data Output. Differential PECL: These ECL 100k outputs represent the recovered data from the input data stream (RDIN). This recovered data is specified against the rising edge of RCLK.
22, 21	21, 20	RCLKP, RCLKN	Clock Output. Differential PECL: These ECL 100k outputs represent the recovered clock used to sample the recovered data (RDOU).
19, 18	18, 17	TCLKP, TCLKN	Clock Output. Differential PECL: These ECL 100k outputs represent either the recovered clock (CLKSEL = HIGH) used to sample the recovered data (RDOU) or the transmit clock of the frequency synthesizer (CLKSEL = LOW).
11, 12	9, 10	PLLSP, PLL SN	Clock Synthesis PLL Loop Filter: External loop filter pins for the clock synthesis PLL.
16, 15	15, 14	PLL RP, PLL RN	Clock Recovery PLL Loop Filter: External loop filter pins for the receiver PLL.

Power and Ground

Pin Number (28-SOIC)	Pin Number (32-TQFP)	Pin Name	Pin Name
28	27, 28	VCC	Supply Voltage ⁽¹⁾
1	29, 30	VCCA	Analog Supply Voltage ⁽¹⁾
20, 23	19, 22	VCCO	Output Supply Voltage ⁽¹⁾
13, 14	12, 13	GND	Ground.
10	1, 8	NC	No connect.
	11	GND A	Analog Ground.

Note:

1. VCC, VCCA, VCCO must be the same value.

Absolute Maximum Ratings⁽¹⁾

Supply Voltage (V_{CC}) -0.5V to +4.0V
 Input Voltage (V_{IN}) -0.5V to V_{CC}
 Output Current (I_{OUT})
 Continuous ± 50 mA
 Surge ± 100 mA
 Lead Temperature (soldering, 20sec.) +260°C
 Storage Temperature (T_s) -65°C to +150°C

Operating Ratings⁽²⁾

Input Voltage (V_{CC}) -3.15V to +3.45V
 Ambient Temperature (T_A) -40°C to +85°C
 Junction Thermal Resistance⁽³⁾
 SOIC (θ_{JA})⁽⁴⁾ 80°C/W
 EPAD-SOIC (θ_{JA})⁽⁵⁾ 27.3°C/W
 EPAD-TQFP (θ_{JA})⁽⁵⁾
 0lfpm airflow 27.6°C/W
 200lfpm airflow 22.6°C/W
 500lfpm airflow 20.7°C/W

DC Electrical Characteristics

Symbol	Parameter	Condition	Min	Typ	Max	Units
V_{CC}	Power Supply Voltage		3.15	3.3	3.45	V
I_{CC}	Power Supply Current			120	160	mA

PECL 100K DC Electrical Characteristics

$V_{CC} = V_{CCO} = V_{CCA} = 3.3V \pm 5\%$; $T_A = -40^\circ C$ to $+85^\circ C$, unless otherwise noted.

Symbol	Parameter	Condition	Min	Typ	Max	Units
V_{IH}	Input HIGH Voltage		$V_{CC}-1.165$		$V_{CC}-0.880$	V
V_{IL}	Input LOW Voltage		$V_{CC}-1.810$		$V_{CC}-1.475$	V
V_{OH}	Output HIGH Voltage	50Ω to $V_{CC}-2V$	$V_{CC}-1.075$		$V_{CC}-0.830$	V
V_{OL}	Output LOW Voltage	50Ω to $V_{CC}-2V$	$V_{CC}-1.860$		$V_{CC}-1.570$	V
I_{IL}	Input LOW Current	$V_{IN} = V_{IL}$ (Min)	0.5			μA

TTL DC Electrical Characteristics

$V_{CC} = V_{CCO} = V_{CCA} = 3.3V \pm 5\%$; $T_A = -40^\circ C$ to $+85^\circ C$, unless otherwise noted.

Symbol	Parameter	Condition	Min	Typ	Max	Units
V_{IH}	Input HIGH Voltage		2.0		V_{CC}	V
V_{IL}	Input LOW Voltage				0.8	V
V_{OH}	Output HIGH Voltage	$I_{OH} = -0.4mA$	2.0			V
V_{OL}	Output LOW Voltage	$I_{OL} = 4mA$			0.5	V
I_{IH}	Input HIGH Current	$V_{IN} = 2.7V, V_{CC} = Max.$ $V_{IN} = V_{CC}, V_{CC} = Max.$	-175		+100	μA μA
I_{IL}	Input LOW Current	$V_{IN} = 0.5V, V_{CC} = Max.$	-300			μA
I_{OS}	Output Short-Circuit Current	$V_{OUT} = 0V, (Max., 1 sec.)$	-15		-100	mA

Notes:

1. Permanent device damage may occur if absolute maximum ratings are exceeded. This is a stress rating only and functional operation is not implied at conditions other than those detailed in the operational sections of this data sheet. Exposure to absolute maximum rating conditions for extended periods may affect device reliability.
2. The data sheet limits are not guaranteed if the device is operated beyond the operating ratings.
3. Airflow of 500lfpm recommended for 28-pin SOIC.
4. 28-pin SOIC package is NOT recommended for new designs.
5. Using JEDEC standard test boards with die attach pad soldered to PCB. See www.amkor.com for additional package details.

AC Electrical Characteristics

$V_{CC} = V_{CCO} = V_{CCA} = 3.3V \pm 5\%$; $T_A = -40^{\circ}C$ to $+85^{\circ}C$, unless otherwise noted.

Symbol	Parameter	Condition	Min	Typ	Max	Units
f_{VCO}	VCO Center Frequency	$f_{REFCLK} \times \text{Byte Rate}$	750		1250	MHz
Δf_{VCO}	VCO Center Frequency Tolerance	Nominal		5		%
t_{ACQ}	Acquisition Lock Time	50Ω to $V_{CC}-2V$			15	μs
t_{CPWH}	REFCLK Pulse Width HIGH	50Ω to $V_{CC}-2V$	4			ns
t_{CPWL}	REFCLK Pulse Width LOW	$V_{IN} = V_{IL} (\text{Min})$	4			ns
t_{ir}	REFCLK Input Rise Time			0.5	2	ns
t_{ODC}	Output Duty Cycle (RCLK/TCLK)		45		55	% of UI
t_r, t_f	ECL Output Rise/Fall Time (20% to 80%)	50Ω to $V_{CC}-2$	100		400	ps
t_{SKEW}	Recovered Clock Skew		-200		+200	ps
t_{DV}	Data Valid		$1/(2 \times f_{RCLK}) - 200$			ps
t_{DH}	Data Hold		$1/(2 \times f_{RCLK}) - 200$			ps

Timing Waveforms

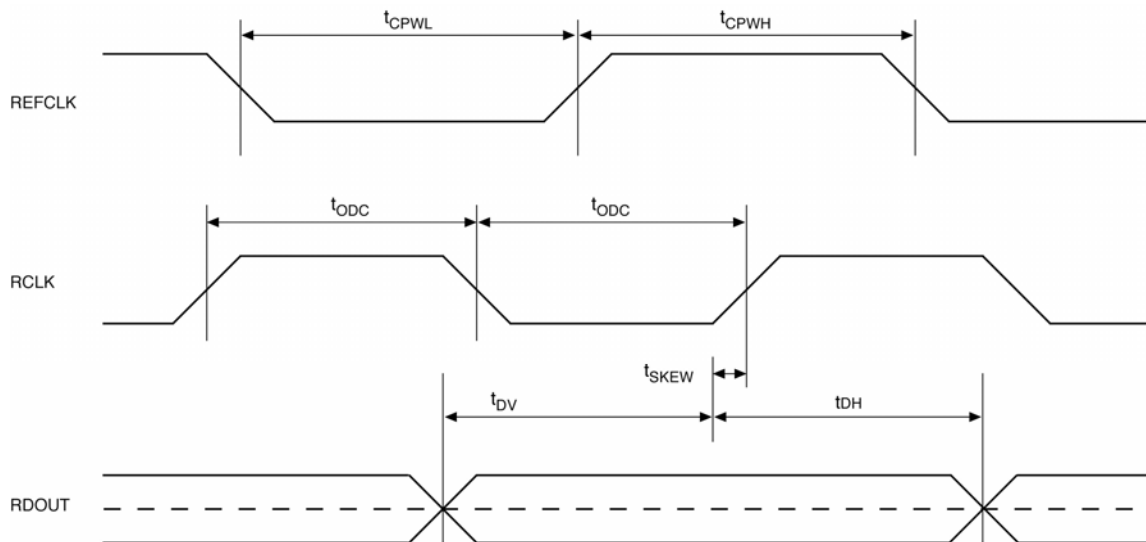

Functional Block

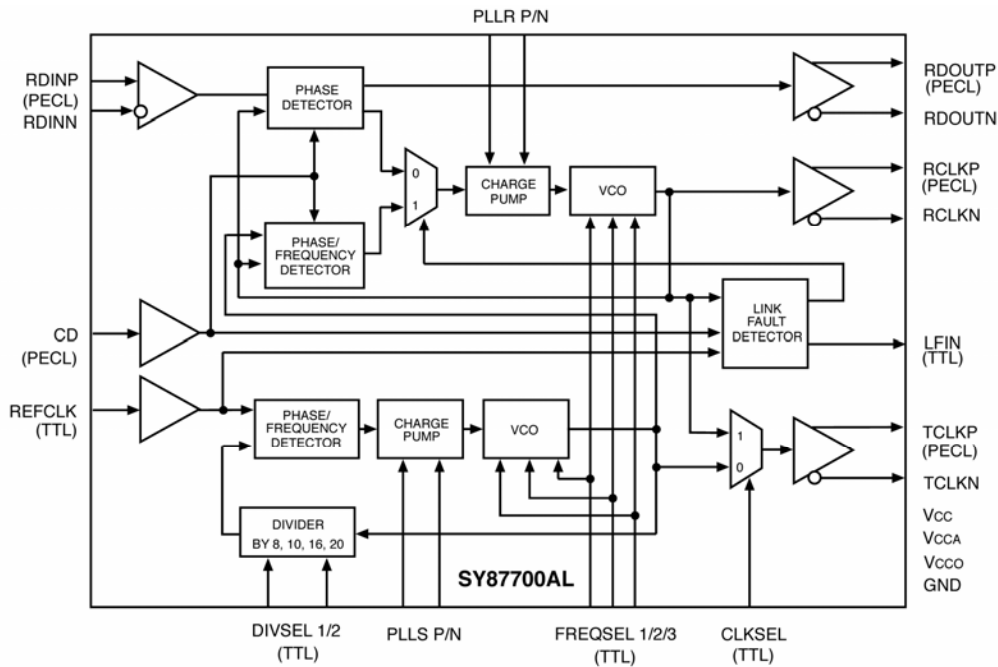

Functional Description

Clock Recovery

Clock recovery, as shown in the block diagram, generates a clock that is at the same frequency as the incoming data bit rate at the serial data input. The clock is phase aligned by a PLL so that it samples the data in the center of the data eye pattern.

The phase relationship between the edge transitions of the data and those of the generated clock are compared by a phase/frequency detector. Output pulses from the detector indicate the required direction of phase correction. These pulses are smoothed by an integral loop filter. The output of the loop filter controls the frequency of the Voltage Controlled Oscillator (VCO), which generates the recovered clock.

Frequency stability, without incoming data, is guaranteed by an alternate reference input (REFCLK) that the PLL locks onto when data is lost. If the frequency of the incoming signal varies by greater than approximately 1000ppm with respect to the synthesizer frequency, the PLL will be declared out of lock, and the PLL will lock to the reference clock.

The loop filter transfer function is optimized to enable the PLL to track the jitter, yet tolerate the minimum transition density expected in a received SONET data signal. This transfer function yields a 30µs data stream of continuous 1's or 0's for random incoming NRZ data.

Lock Detect

The SY87700AL contains a link fault indication circuit, which monitors the integrity of the serial data inputs. If the received serial data fails the frequency test, then the PLL will be forced to lock to the local reference clock. This will maintain the correct frequency of the recovered clock output under loss of signal or loss of lock conditions. If the recovered clock frequency deviates from the local reference clock frequency by more than approximately 1000ppm, the PLL will be declared out of lock. The lock detect circuit will poll the input data stream in an attempt to reacquire lock to data. If the recovered clock frequency is determined to be within approximately 1000ppm, the PLL will be declared in lock and the lock detect output will go active.

During the interval when the CDR is not locked onto the RDIN input, the LFIN output will not be a static LOW, but will be changing.

Frequency Selection Table

FREQSEL1	FREQSEL2	FREQSEL3	f_{VCO}/f_{RCLK}	f_{RCLK} Data Rates (Mbps)
0	1	1	6	125 to 208
1	0	0	8	94 to 156
1	0	1	12	63 to 104
1	1	0	16	47 to 78
1	1	1	24	32 to 52
0	1	0	—	undefined
0	0	X ⁽²⁾	—	undefined

Notes:

1. SY87700AL operates from 32MHz to 208MHz. For higher speed applications, the SY87701AL operates from 28MHz to 1300MHz.
2. X is a DON'T CARE.

Reference Frequency Selection

DIVSEL1	DIVSEL2	f_{RCLK}/f_{REFCLK}
0	0	8
0	1	10
1	0	16
1	1	20

Loop Filter Components⁽¹⁾

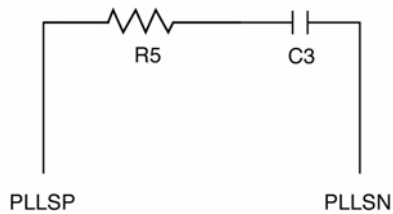

R5 = 350Ω
 C3 = 1.0μF (X7R Dielectric)

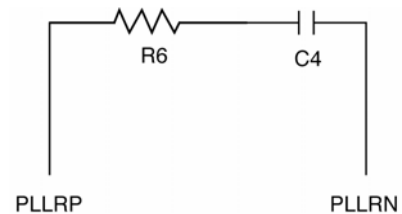

R5 = 680Ω
 C3 = 1.0μF (X7R Dielectric)

Note:

1. Suggested values. Values may vary for different applications.

Application Example AC-Coupled I/O

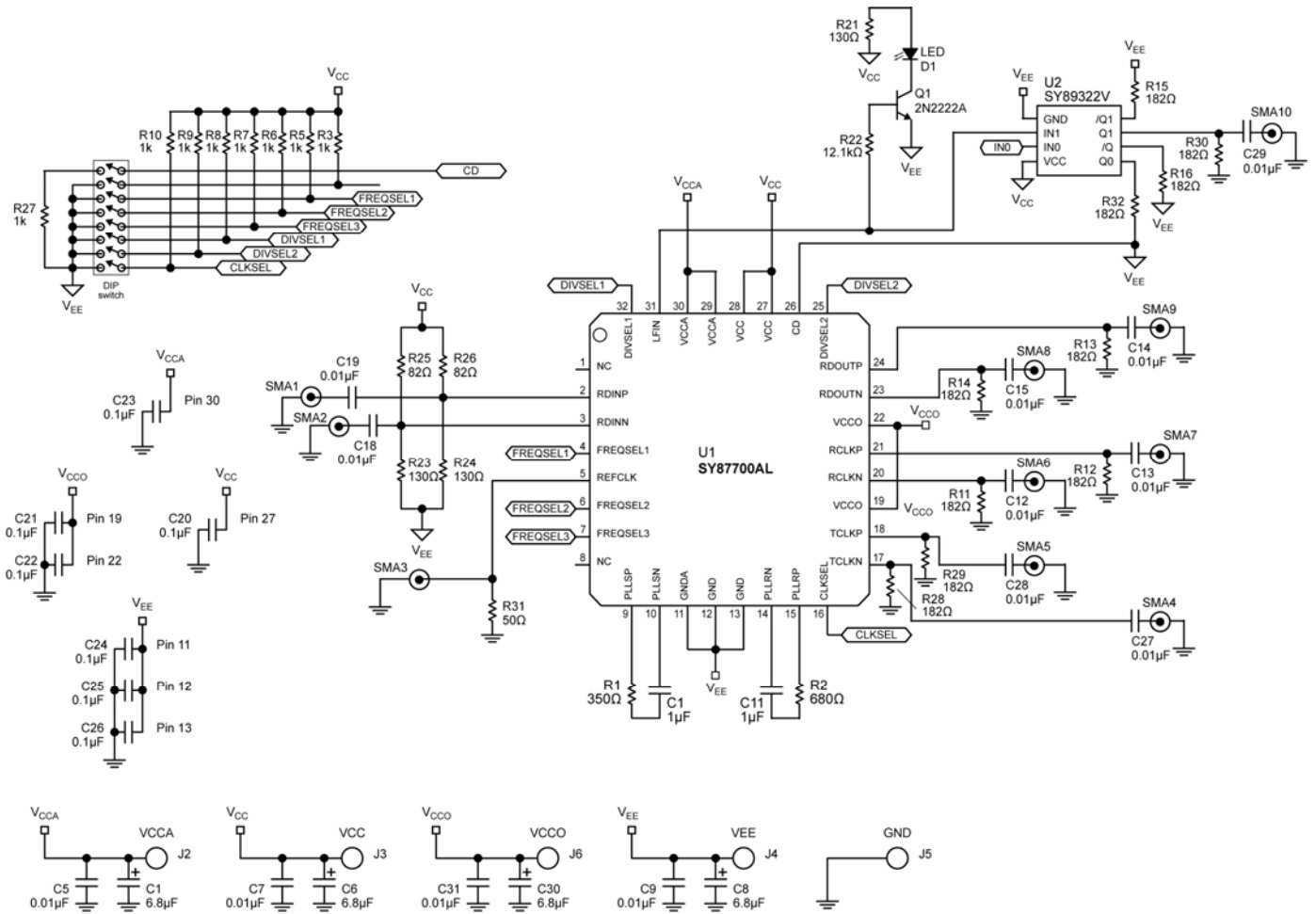

Application Example DC-Coupled I/O

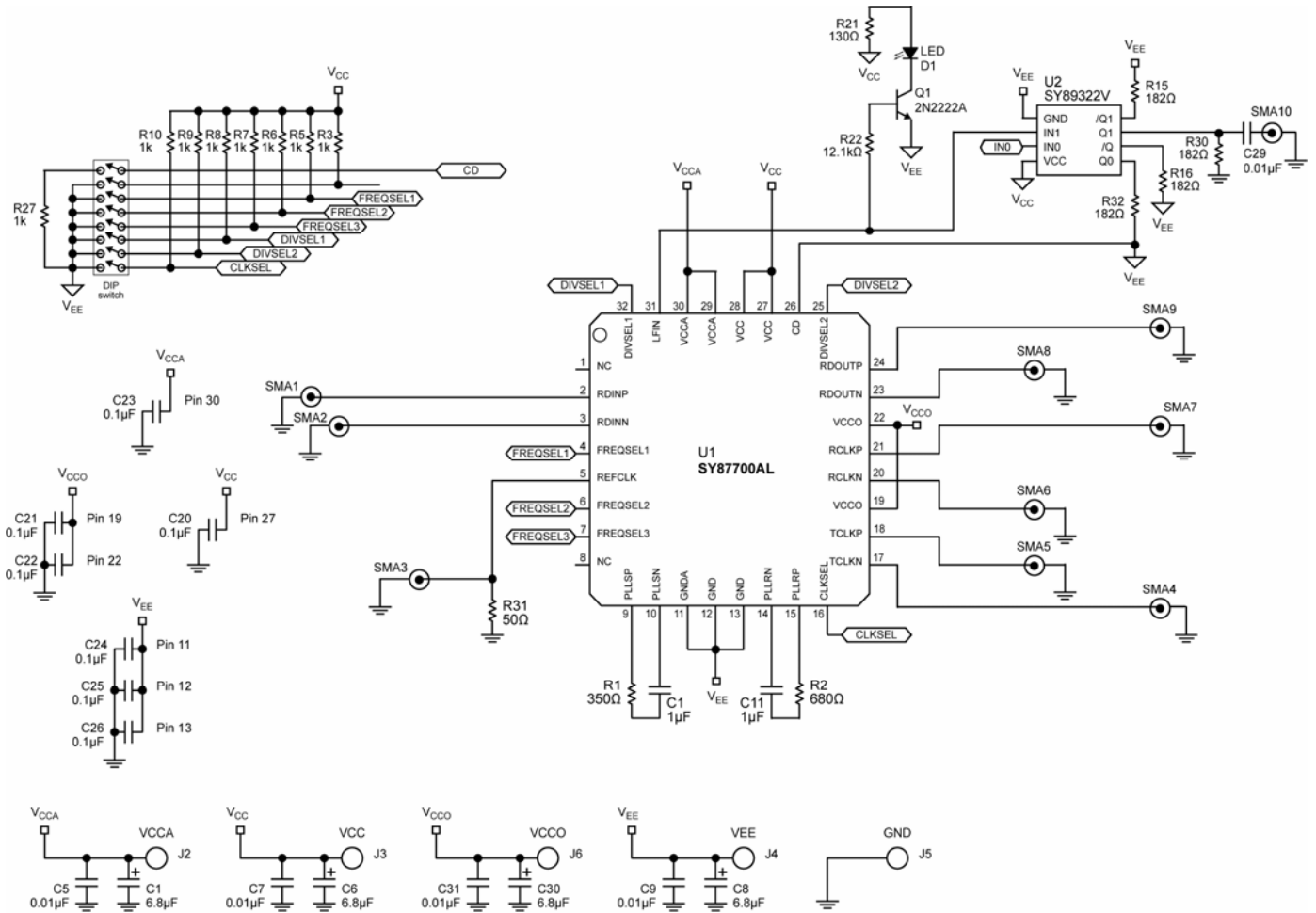

Related Product and Support Documentation

Part Number	Function	Data Sheet Link
SY87701AL	Low-Power 3.3V, 28Mbps to 1300Mbps AnyRate [®] Clock and Data Recovery	www.micrel.com/product-info/products/sy87701al.shtml
HBW Solutions	New Products and Applications	www.micrel.com/product-info/products/solutions.shtml

Bill of Materials (AC-Coupled)

Item	Part Number	Manufacturer	Description	Qty.
C6	293D685X0025B2T	Vishay ⁽¹⁾	6.8μF, 25V, Tantalum Capacitor, Size B	1
C7	VJ206Y103JXJAT	Vishay ⁽¹⁾	0.01μF Ceramic Capacitor, Size 1206, X7R Dielectric	1
C10, C11	VJ0603Y105JXJAT	Vishay ⁽¹⁾	1.0μF Ceramic Capacitor, Size 0603, X7R Dielectric	2
C12-C15, C18, C19, C27, C28	VJ0402Y104JXJAT	Vishay ⁽¹⁾	0.1μF Ceramic Capacitor, Size 0402, X7R Dielectric	8
C20-C26	VJ0402Y104JXJAT	Vishay ⁽¹⁾	0.01μF Ceramic Capacitor, Size 1206, X7R Dielectric	7
D1	P301-ND	Panasonic ⁽²⁾	LED Diode, T-1 3/4, Red Clear	1
D2	P300-ND/P301-ND	Vishay ⁽¹⁾	T-1 3/4, Red LED	1
J2, J3, J4, J6	111-0702-001	Johnson Components ⁽³⁾	Red, Insulated Thumb Nut Binding Post (Jumped Together)	4
J5	BLM21A102F	Murata ⁽⁴⁾	Black, Insulated Thumb Nut Binding Post, GND (Jumped to V _{EE})	1
Q1	459-2598-5-ND	NTE ⁽⁵⁾	2N2222A Buffer/Driver Transistor, NPN	1
R1	CRCW04023500F	Vishay ⁽¹⁾	350Ω Resistor, 2%, Size 0402	1
R2	CRCW04026800F	Vishay ⁽¹⁾	680Ω Resistor, 2%, Size 0402	1
R3–R10	CRCW04021001F	Vishay ⁽¹⁾	1kΩ Pull-up Resistor, 2%, Size 1206	8
R11-R16, R28-R30, R32	CRCW04021820F	Vishay ⁽¹⁾	182Ω Resistor, 2%, Size 0402	10
R21	CRCW06031300F	Vishay ⁽¹⁾	130Ω Resistor, 2%, Size 0603	1
R22	CRCW04021820F	Vishay ⁽¹⁾	12.1kΩ Resistor, 2%, Size 1206	1
R23, R24	CRCW04022825F	Vishay ⁽¹⁾	82Ω Resistor, 2%, Size 0402	2
R25, R26	CRCW04021300F	Vishay ⁽¹⁾	130Ω Resistor, 2%, Size 0402	2
R27	CRCW04020OR0F	Vishay ⁽¹⁾	0Ω Resistor, 2%, Size 0402	1
R31	CRCW04025000F	Vishay ⁽¹⁾	50Ω Resistor, 2%, Size 0402	1
SMA1- SMA10	142-0701-851	Johnson Components ⁽³⁾	End Launch SMA Jack	10
SP1-SP6			Solder Jump Option	6
SW1	CT2068-ND	CTS ⁽⁶⁾	8-Position, Top Actuated Slide Dip Switch	1
U1	SY87700AL	Micrel, Inc. ⁽⁷⁾	Low-Power 3.3V 28Mbps to 216Mbps AnyRate® Clock and Data Recovery	1
U2	SY89322V	Micrel, Inc. ⁽⁷⁾	3.3/5V Dual LVTTTL/LVCMOS-to-Differential LVPECL Translator	1

Notes:

1. Vishay: www.vishay.com.
2. Panasonic: www.panasonic.com.
3. Johnson Components: www.johnson-components.com.
4. Murata: www.murata.com.
5. NTE: www.nte.com.
6. CTS: www.cts.com.
7. **Micrel, Inc:** www.micrel.com.

Bill of Materials (DC-Coupled)

Item	Part Number	Manufacturer	Description	Qty.
C6	293D685X0025B2T	Vishay ⁽¹⁾	6.8μF, 25V, Tantalum Capacitor, Size B	1
C7	VJ206Y103JXJAT	Vishay ⁽¹⁾	0.01μF Ceramic Capacitor, Size 1206, X7R Dielectric	1
C10, C11	VJ0603Y105JXJAT	Vishay ⁽¹⁾	1.0μF Ceramic Capacitor, Size 0603, X7R Dielectric	2
C12-C15, C18, C19, C27, C28	VJ0402Y104JXJAT	Vishay ⁽¹⁾	0.1μF Ceramic Capacitor, Size 0402, X7R Dielectric	8
C20-C26	VJ0402Y104JXJAT	Vishay ⁽¹⁾	0.01μF Ceramic Capacitor, Size 1206, X7R Dielectric	7
D1	P301-ND	Panasonic ⁽²⁾	LED Diode, T-1 3/4, Red Clear	1
D2	P300-ND/P301-ND	Vishay ⁽¹⁾	T-1 3/4, Red LED	1
J2, J3, J4, J6	111-0702-001	Johnson Components ⁽³⁾	Red, Insulated Thumb Nut Binding Post (Jumped Together)	4
J5	BLM21A102F	Johnson Components ⁽³⁾	Black, Insulated Thumb Nut Binding Post, GND (Jumped to V _{EE})	1
Q1	459-2598-5-ND	NTE ⁽⁵⁾	2N2222A Buffer/Driver Transistor, NPN	1
R1	CRCW04023500F	Vishay ⁽¹⁾	350Ω Resistor, 2%, Size 0402	1
R2	CRCW04026800F	Vishay ⁽¹⁾	680Ω Resistor, 2%, Size 0402	1
R3–R10	CRCW04021001F	Vishay ⁽¹⁾	1kΩ Pull-up Resistor, 2%, Size 1206	8
R15, R16, R30, R32	CRCW04021820F	Vishay ⁽¹⁾	182Ω Resistor, 2%, Size 0402	10
R21	CRCW06031300F	Vishay ⁽¹⁾	130Ω Resistor, 2%, Size 0603	1
R22	CRCW04021820F	Vishay ⁽¹⁾	12.1kΩ Resistor, 2%, Size 1206	1
R23, R24	CRCW04022825F	Vishay ⁽¹⁾	82Ω Resistor, 2%, Size 0402	2
R27	CRCW04020OR0F	Vishay ⁽¹⁾	0Ω Resistor, 2%, Size 0402	1
R31	CRCW04025000F	Vishay ⁽¹⁾	50Ω Resistor, 2%, Size 0402	1
SMA1- SMA10	142-0701-851	Johnson Components ⁽³⁾	End Launch SMA Jack	10
SP1-SP6			Solder Jump Option	6
SW1	CT2068-ND	CTS ⁽⁶⁾	8-Position, Top Actuated Slide Dip Switch	1
U1	SY87700AL	Micrel, Inc. ⁽⁷⁾	Low-Power 3.3V 28Mbps to 216Mbps AnyRate® Clock and Data Recovery	1
U2	SY89322V	Micrel, Inc. ⁽⁷⁾	3.3/5V Dual LVTTTL/LVCMOS-to-Differential LVPECL Translator	1

Notes:

5. Vishay: www.vishay.com.
6. Panasonic: www.panasonic.com.
7. Johnson Components: www.johnson-components.com.
8. Murata: www.murata.com.
5. NTE: www.ntec.com.
6. CTS: www.cts.com.
7. **Micrel, Inc:** www.micrel.com.

Appendix A

Layout and General Suggestions

1. Establish controlled impedance stripline, microstrip, or coplanar construction techniques.
2. Signal paths should have approximately the same width as the device pads.
3. All differential paths are critical timing paths, where skew should be matched to within ± 10 ps.
4. Signal trace impedance should not vary more than $\pm 5\%$. If in doubt, perform TDR analysis of all high-speed signal traces.
5. Maintain compact filter networks as close to filter pins as possible. Provide ground plane relief under filter path to reduce stray capacitance. Be careful of crosstalk coupling into the filter network.
6. Maintain low jitter on the REFCLK input. Isolate the XTAL oscillator from power supply noise by adequately decoupling. Keep XTAL oscillator close to device, and minimize capacitive coupling from adjacent signals.
7. Higher speed operation may require use of fundamental-tone (third-overtone typically has more jitter) crystal-based oscillator for optimum performance. Evaluate and compare candidates by measuring TXCLK jitter.
8. All unused outputs must be terminated. To conserve power, unused PECL outputs can be terminated with a $1\text{k}\Omega$ resistor to V_{EE} .

Package Information

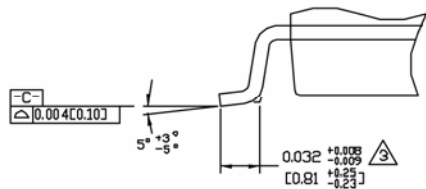
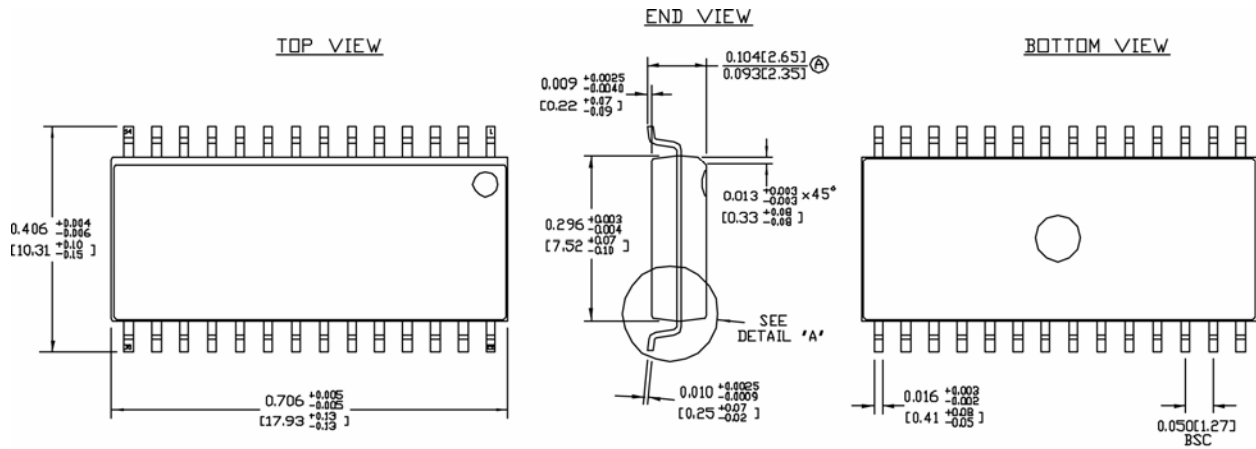

NOTES:

1. DIMENSIONS ARE IN INCHES[MM].
2. CONTROLLING DIMENSION: INCHES.
3. DIMENSION DOES NOT INCLUDE MOLD FLASH OR PROTRUSIONS, EITHER OF WHICH SHALL NOT EXCEED 0.006[0.15] PER SIDE.
4. MAXIMUM AND MINIMUM SPECIFICATIONS ARE INDICATED AS FOLLOWS: MAX
MIN

28-Pin SOIC .300" Wide (Z28-1)

Note:

1. The 28-pin SOIC package is NOT recommended for new designs.

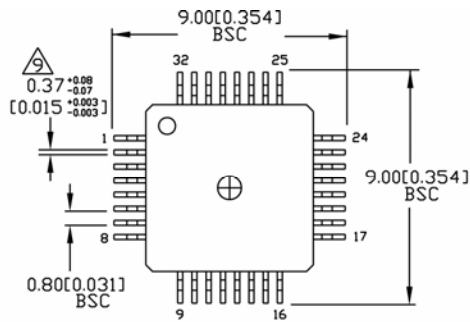

TOP VIEW

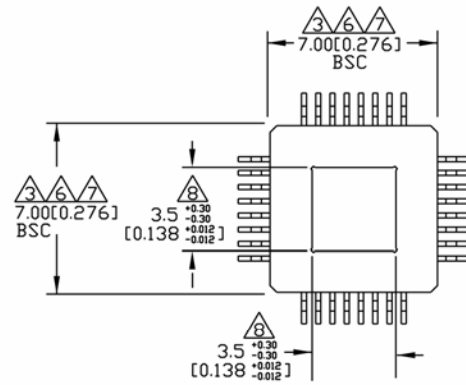

BOTTOM VIEW

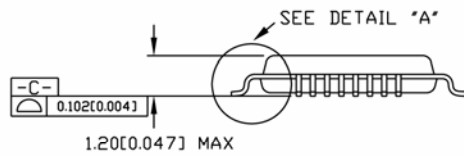

SIDE VIEW

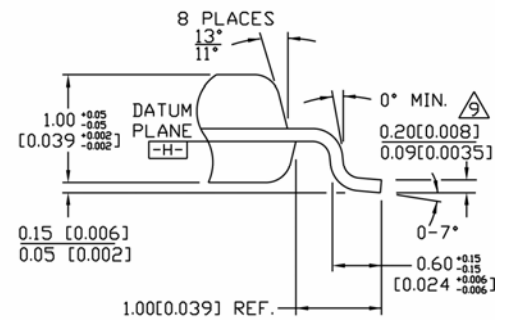

DETAIL "A"

NOTES:

1. DIMENSIONS ARE IN MM[INCHES].
2. CONTROLLING DIMENSION: MM.
3. DIMENSION DOES NOT INCLUDE MOLD FLASH OR PROTRUSIONS, EITHER OF WHICH SHALL NOT EXCEED 0.254 [0.010].
4. LEAD DIMENSION DOES NOT INCLUDE DAMBAR PROTRUSION.
5. MAXIMUM AND MINIMUM SPECIFICATIONS ARE INDICATED AS FOLLOWS: MAX/MIN.
6. THESE DIMENSIONS TO BE DETERMINED AT DATUM PLANE [H]
7. PACKAGE TOP DIMENSIONS ARE SMALLER THAN BOTTOM DIMENSIONS AND TOP OF PACKAGE WILL NOT OVERHANG BOTTOM OF PACKAGE.
8. EXPOSED PAD SHALL BE COPLANAR WITH PACKAGE BOTTOM WITHIN 0.05mm
EXPOSED PAD: Cu WITH Sn/Pb PLATING
9. DIMENSION INCLUDES LEAD FINISH.

32-Pin EPAD-TQFP (H32-1)
(Die Up)

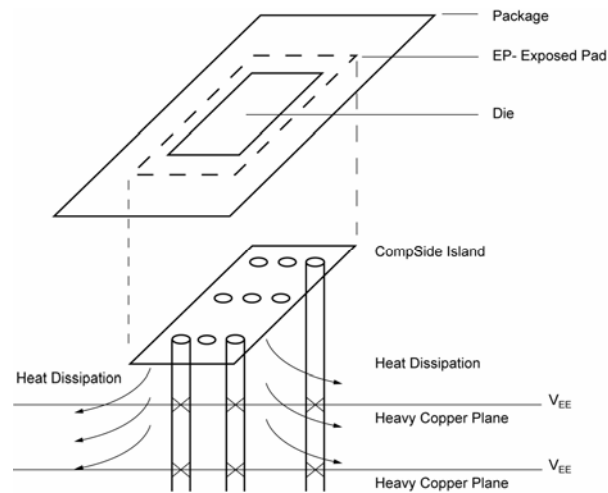

PCB Thermal Consideration for 32-Pin EPAD-TQFP

Package Notes:

1. Package meets Leve 2 moisture sensitivity classification and is shipped in dry-pack form.
2. Exposed pad must be soldered to a ground for proper thermal management.

MICREL, INC. 2180 FORTUNE DRIVE SAN JOSE, CA 95131 USA
 TEL +1 (408) 944-0800 FAX +1 (408) 474-1000 WEB <http://www.micrel.com>

The information furnished by Micrel in this data sheet is believed to be accurate and reliable. However, no responsibility is assumed by Micrel for its use. Micrel reserves the right to change circuitry and specifications at any time without notification to the customer.

Micrel Products are not designed or authorized for use as components in life support appliances, devices or systems where malfunction of a product can reasonably be expected to result in personal injury. Life support devices or systems are devices or systems that (a) are intended for surgical implant into the body or (b) support or sustain life, and whose failure to perform can be reasonably expected to result in a significant injury to the user. A Purchaser's use or sale of Micrel Products for use in life support appliances, devices or systems is a Purchaser's own risk and Purchaser agrees to fully indemnify Micrel for any damages resulting from such use or sale.

© 2006 Micrel, Incorporated.



Компания «ЭлектроПласт» предлагает заключение долгосрочных отношений при поставках импортных электронных компонентов на взаимовыгодных условиях!

Наши преимущества:

- Оперативные поставки широкого спектра электронных компонентов отечественного и импортного производства напрямую от производителей и с крупнейших мировых складов;
- Поставка более 17-ти миллионов наименований электронных компонентов;
- Поставка сложных, дефицитных, либо снятых с производства позиций;
- Оперативные сроки поставки под заказ (от 5 рабочих дней);
- Экспресс доставка в любую точку России;
- Техническая поддержка проекта, помощь в подборе аналогов, поставка прототипов;
- Система менеджмента качества сертифицирована по Международному стандарту ISO 9001;
- Лицензия ФСБ на осуществление работ с использованием сведений, составляющих государственную тайну;
- Поставка специализированных компонентов (Xilinx, Altera, Analog Devices, Intersil, Interpoint, Microsemi, Aeroflex, Peregrine, Syfer, Eurofarad, Texas Instrument, Miteq, Cobham, E2V, MA-COM, Hittite, Mini-Circuits, General Dynamics и др.);

Помимо этого, одним из направлений компании «ЭлектроПласт» является направление «Источники питания». Мы предлагаем Вам помощь Конструкторского отдела:

- Подбор оптимального решения, техническое обоснование при выборе компонента;
- Подбор аналогов;
- Консультации по применению компонента;
- Поставка образцов и прототипов;
- Техническая поддержка проекта;
- Защита от снятия компонента с производства.



Как с нами связаться

Телефон: 8 (812) 309 58 32 (многоканальный)

Факс: 8 (812) 320-02-42

Электронная почта: org@eplast1.ru

Адрес: 198099, г. Санкт-Петербург, ул. Калинина, дом 2, корпус 4, литера А.