

## GENERAL DESCRIPTION

The 83026I-01 is a low skew, 1-to-2 Differential-to-LVCMOS/LVTTL Fanout Buffer. The differential input can accept most differential signal types (LVPECL, LVDS, LVHSTL, HCSL and SSTL) and translate to two single-ended LVCMOS/LVTTL outputs. The small 8-lead SOIC footprint makes this device ideal for use in applications with limited board space.

## FEATURES

- Two LVCMOS / LVTTL outputs
- Differential CLK, nCLK input pair
- CLK, nCLK pair can accept the following differential input levels: LVPECL, LVDS, LVHSTL, HCSL, SSTL
- Maximum output frequency: 350MHz
- Output skew: 15ps (maximum)
- Part-to-part skew: 600ps (maximum)
- Additive phase jitter, RMS: 0.03ps (typical)
- Small 8 lead SOIC package saves board space
- 3.3V core, 3.3V, 2.5V or 1.8V output operating supply
- -40°C to 85°C ambient operating temperature
- Available in lead-free RoHS (6) package

## BLOCK DIAGRAM

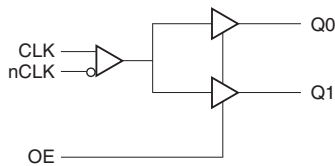

## PIN ASSIGNMENT

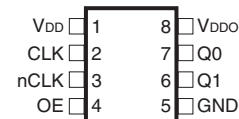

### 83026I-01 8-Lead SOIC

3.8mm x 4.8mm, x 1.47mm package body  
**M Package**  
Top View

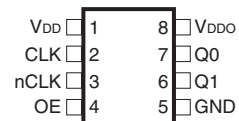

### 83026I-01 8-Lead TSSOP

4.40mm x 3.0mm x 0.925mm  
package body  
**G Package**  
Top View

**TABLE 1. PIN DESCRIPTIONS**

Number	Name	Type		Description
1	V <sub>DD</sub>	Power		Positive supply pin.
2	CLK	Input	Pulldown	Non-inverting differential clock input.
3	nCLK	Input	Pullup/ Pulldown	Inverting differential clock input. V <sub>DD</sub> /2 default when left floating.
4	OE	Input	Pullup	Output enable. When HIGH, outputs are enabled. When LOW, outputs are in High Impedance State. LVCMOS / LVTTTL interface levels.
5	GND	Power		Power supply ground.
6	Q1	Output		Clock output. LVCMOS / LVTTTL interface levels.
7	Q0	Output		Clock output. LVCMOS / LVTTTL interface levels.
8	V <sub>DDO</sub>	Power		Output supply pin.

NOTE: *Pullup* and *Pulldown* refer to internal input resistors. See Table 2, Pin Characteristics, for typical values.

**TABLE 2. PIN CHARACTERISTICS**

Symbol	Parameter	Test Conditions	Minimum	Typical	Maximum	Units
C <sub>IN</sub>	Input Capacitance			4		pF
C <sub>PD</sub>	Power Dissipation Capacitance (per output)	V <sub>DD</sub> , V <sub>DDO</sub> = 3.465V			17	pF
		V <sub>DD</sub> = 3.465V, V <sub>DDO</sub> = 2.625V			16	pF
		V <sub>DD</sub> = 3.465V, V <sub>DDO</sub> = 1.95V			15	pF
R <sub>PULLUP</sub>	Input Pullup Resistor			51		kΩ
R <sub>PULLDOWN</sub>	Input Pulldown Resistor			51		kΩ
R <sub>OUT</sub>	Output Impedance	V <sub>DD</sub> , V <sub>DDO</sub> = 3.3V		7		Ω
		V <sub>DD</sub> = 3.3V, V <sub>DDO</sub> = 2.5V		8		Ω
		V <sub>DD</sub> = 3.3V, V <sub>DDO</sub> = 1.8V		10		Ω

**TABLE 3. CONTROL FUNCTION TABLE**

Input	Outputs
OE	Q0, Q1
0	HiZ
1	Active

**ABSOLUTE MAXIMUM RATINGS**

Supply Voltage, $V_{DD}$	4.6V
Inputs, $V_I$	-0.5V to $V_{DD} + 0.5V$
Outputs, $V_O$	-0.5V to $V_{DDO} + 0.5V$
Package Thermal Impedance, $\theta_{JA}$	
8 Lead SOIC	112.7°C/W (0 lfpm)
8 Lead TSSOP	101.7°C/W (0 lfpm)
Storage Temperature, $T_{STG}$	-65°C to 150°C

NOTE: Stresses beyond those listed under Absolute Maximum Ratings may cause permanent damage to the device. These ratings are stress specifications only. Functional operation of product at these conditions or any conditions beyond those listed in the *DC Characteristics* or *AC Characteristics* is not implied. Exposure to absolute maximum rating conditions for extended periods may affect product reliability.

**TABLE 3A. POWER SUPPLY DC CHARACTERISTICS,  $V_{DD} = 3.3V \pm 5\%$ ,  $V_{DDO} = 1.71V$  TO  $3.465V$ ,  $T_A = -40^\circ C$  TO  $85^\circ C$** 

Symbol	Parameter	Test Conditions	Minimum	Typical	Maximum	Units
$V_{DD}$	Positive Supply Voltage		3.135	3.3	3.465	V
$V_{DDO}$	Output Supply Voltage		3.135	3.3	3.465	V
			2.375	2.5	2.625	V
			1.71	1.8	1.89	V
$I_{DD}$	Power Supply Current			10	mA	
$I_{DDO}$	Output Supply Current			3	mA	

**TABLE 3B. LVCMOS / LVTTTL DC CHARACTERISTICS,  $V_{DD} = 3.3V \pm 5\%$ ,  $V_{DDO} = 2.375V$  TO  $3.465V$ ,  $T_A = -40^\circ C$  TO  $85^\circ C$** 

Symbol	Parameter	Test Conditions	Minimum	Typical	Maximum	Units
$V_{IH}$	Input High Voltage	OE	2		$V_{DD} + 0.3$	V
$V_{IL}$	Input Low Voltage	OE	-0.3		0.8	V
$I_{IH}$	Input High Current	OE	$V_{DD} = V_{IN} = 3.465V$		5	$\mu A$
$I_{IL}$	Input Low Current	OE	$V_{DD} = 3.465V, V_{IN} = 0V$			$\mu A$
$V_{OH}$	Output High Voltage; NOTE 1		$V_{DDO} = 3.135V$		2.6	V
			$V_{DDO} = 2.375V$		1.8	V
$V_{OL}$	Output Low Voltage; NOTE 1				0.5	V

NOTE 1: Outputs terminated with  $50\Omega$  to  $V_{DDO}/2$ . See Parameter Measurement Information section, "Output Load Test Circuit" diagrams.

**TABLE 3C. LVCMOS / LVTTTL DC CHARACTERISTICS,  $V_{DD} = 3.3V \pm 5\%$ ,  $V_{DDO} = 1.8V \pm 5\%$ ,  $T_A = -40^\circ C$  TO  $85^\circ C$** 

Symbol	Parameter	Test Conditions	Minimum	Typical	Maximum	Units
$V_{IH}$	Input High Voltage	OE	2		$V_{DD} + 0.3$	V
$V_{IL}$	Input Low Voltage	OE	-0.3		0.8	V
$I_{IH}$	Input High Current	OE	$V_{DD} = V_{IN} = 3.465V$		5	$\mu A$
$I_{IL}$	Input Low Current	OE	$V_{DD} = 3.465V, V_{IN} = 0V$		-150	$\mu A$
$V_{OH}$	Output High Voltage		$I_{OH} = -100\mu A$		$V_{DDO} - 0.2$	V
			$I_{OH} = -2mA$		$V_{DDO} - 0.45$	V
$V_{OL}$	Output Low Voltage		$I_{OL} = 100\mu A$		0.2	V
			$I_{OL} = 2mA$		0.45	V

**TABLE 3D. DIFFERENTIAL DC CHARACTERISTICS,  $V_{DD} = 3.3V \pm 5\%$ ,  $V_{DDO} = 1.71V$  TO  $3.465V$ ,  $T_A = -40^{\circ}C$  TO  $85^{\circ}C$** 

Symbol	Parameter	Test Conditions	Minimum	Typical	Maximum	Units
$I_{IH}$	Input High Current	nCLK	$V_{IN} = V_{DD} = 3.465V$		150	$\mu A$
		CLK	$V_{IN} = V_{DD} = 3.465V$		150	$\mu A$
$I_{IL}$	Input Low Current	nCLK	$V_{IN} = 0V, V_{DD} = 3.465V$	-150		$\mu A$
		CLK	$V_{IN} = 0V, V_{DD} = 3.465V$	-5		$\mu A$
$V_{PP}$	Peak-to-Peak Input Voltage; NOTE 1		0.15		1.3	V
$V_{CMR}$	Common Mode Input Voltage; NOTE 2, 3		GND + 0.5		$V_{DD} - 0.85$	V

NOTE 1:  $V_{PP}$  can exceed 1.3V provided that there is sufficient offset level to keep  $V_{IL} > 0V$ .

NOTE 2: For single ended applications, the maximum input voltage for CLK, nCLK is  $V_{DD} + 0.3V$ .

NOTE 3: Common mode voltage is defined as  $V_{IH}$ .

**TABLE 4A. AC CHARACTERISTICS,  $V_{DD} = 3.3V \pm 5\%$ ,  $V_{DDO} = 3.3V \pm 5\%$ ,  $T_A = -40^{\circ}C$  TO  $85^{\circ}C$** 

Symbol	Parameter	Test Conditions	Minimum	Typical	Maximum	Units
$f_{MAX}$	Output Frequency				350	MHz
$t_{PD}$	Propagation Delay; NOTE 1	$f \leq 350MHz$	1.3	1.9	2.5	ns
$t_{sk(o)}$	Output Skew; NOTE 2, 4				15	ps
$t_{sk(pp)}$	Part-to-Part Skew; NOTE 3, 4				900	ps
$t_{jit}$	Buffer Additive Phase Jitter, RMS, refer to Additive Phase Jitter Section			0.03		ps
$t_R / t_F$	Output Rise/Fall Time	20% to 80%	150		800	ps
odc	Output Duty Cycle	$f \leq 66MHz$	48		52	%
		$67MHz \leq f \leq 166MHz$	45		55	%
		$167MHz \leq f \leq 350MHz$	40		60	%

NOTE 1: Measured from the differential input crossing point to  $V_{DDO}/2$  of the output.

NOTE 2: Defined as skew between outputs at the same supply voltage and with equal load conditions.

Measured at  $V_{DDO}/2$ .

NOTE 3: Defined as skew between outputs on different devices operating at the same supply voltages and with equal load conditions. Using the same type of inputs on each device, the outputs are measured at  $V_{DDO}/2$ .

NOTE 4: This parameter is defined in accordance with JEDEC Standard 6.

**TABLE 4B. AC CHARACTERISTICS,  $V_{DD} = 3.3V \pm 5\%$ ,  $V_{DDO} = 2.5V \pm 5\%$ ,  $T_A = -40^{\circ}C$  TO  $85^{\circ}C$** 

Symbol	Parameter	Test Conditions	Minimum	Typical	Maximum	Units
$f_{MAX}$	Output Frequency				350	MHz
$t_{PD}$	Propagation Delay; NOTE 1	$f \leq 350MHz$	1.5	2.0	2.6	ns
$tsk(o)$	Output Skew; NOTE 2, 4				15	ps
$tsk(pp)$	Part-to-Part Skew; NOTE 3, 4				750	ps
$t_{jit}$	Buffer Additive Phase Jitter, RMS, refer to Additive Phase Jitter Section			0.03		ps
$t_R / t_F$	Output Rise/Fall Time	20% to 80%	150		800	ps
odc	Output Duty Cycle	$f \leq 66MHz$	48		52	%
		$67MHz \leq f \leq 166MHz$	46		54	%
		$167MHz \leq f \leq 350MHz$	40		60	%

NOTE 1: Measured from the differential input crossing point to  $V_{DDO}/2$  of the output.

NOTE 2: Defined as skew between outputs at the same supply voltage and with equal load conditions.

Measured at  $V_{DDO}/2$ .

NOTE 3: Defined as skew between outputs on different devices operating at the same supply voltages and with equal load conditions. Using the same type of inputs on each device, the outputs are measured at  $V_{DDO}/2$ .

NOTE 4: This parameter is defined in accordance with JEDEC Standard 65.

**TABLE 4C. AC CHARACTERISTICS,  $V_{DD} = 3.3V \pm 5\%$ ,  $V_{DDO} = 1.8V \pm 5\%$ ,  $T_A = -40^{\circ}C$  TO  $85^{\circ}C$** 

Symbol	Parameter	Test Conditions	Minimum	Typical	Maximum	Units
$f_{MAX}$	Output Frequency				350	MHz
$t_{PD}$	Propagation Delay; NOTE 1	$f \leq 350MHz$	1.9	2.5	3.1	ns
$tsk(o)$	Output Skew; NOTE 2, 4				15	ps
$tsk(pp)$	Part-to-Part Skew; NOTE 3, 4				600	ps
$t_{jit}$	Buffer Additive Phase Jitter, RMS, refer to Additive Phase Jitter Section			0.03		ps
$t_R / t_F$	Output Rise/Fall Time	20% to 80%	200		900	ps
odc	Output Duty Cycle	$f \leq 66MHz$	48		52	%
		$67MHz \leq f \leq 166MHz$	43		57	%
		$167MHz \leq f \leq 350MHz$	40		60	%

NOTE 1: Measured from the differential input crossing point to  $V_{DDO}/2$  of the output.

NOTE 2: Defined as skew between outputs at the same supply voltage and with equal load conditions.

Measured at  $V_{DDO}/2$ .

NOTE 3: Defined as skew between outputs on different devices operating at the same supply voltages and with equal load conditions. Using the same type of inputs on each device, the outputs are measured at  $V_{DDO}/2$ .

NOTE 4: This parameter is defined in accordance with JEDEC Standard 65.

## ADDITIVE PHASE JITTER

The spectral purity in a band at a specific offset from the fundamental compared to the power of the fundamental is called the **dBc Phase Noise**. This value is normally expressed using a Phase noise plot and is most often the specified plot in many applications. Phase noise is defined as the ratio of the noise power present in a 1Hz band at a specified offset from the fundamental frequency to the power value of the fundamental. This ratio is expressed in decibels (dBm) or a ratio of the power in the

1Hz band to the power in the fundamental. When the required offset is specified, the phase noise is called a **dBc** value, which simply means dBm at a specified offset from the fundamental. By investigating jitter in the frequency domain, we get a better understanding of its effects on the desired application over the entire time record of the signal. It is mathematically possible to calculate an expected bit error rate given a phase noise plot.

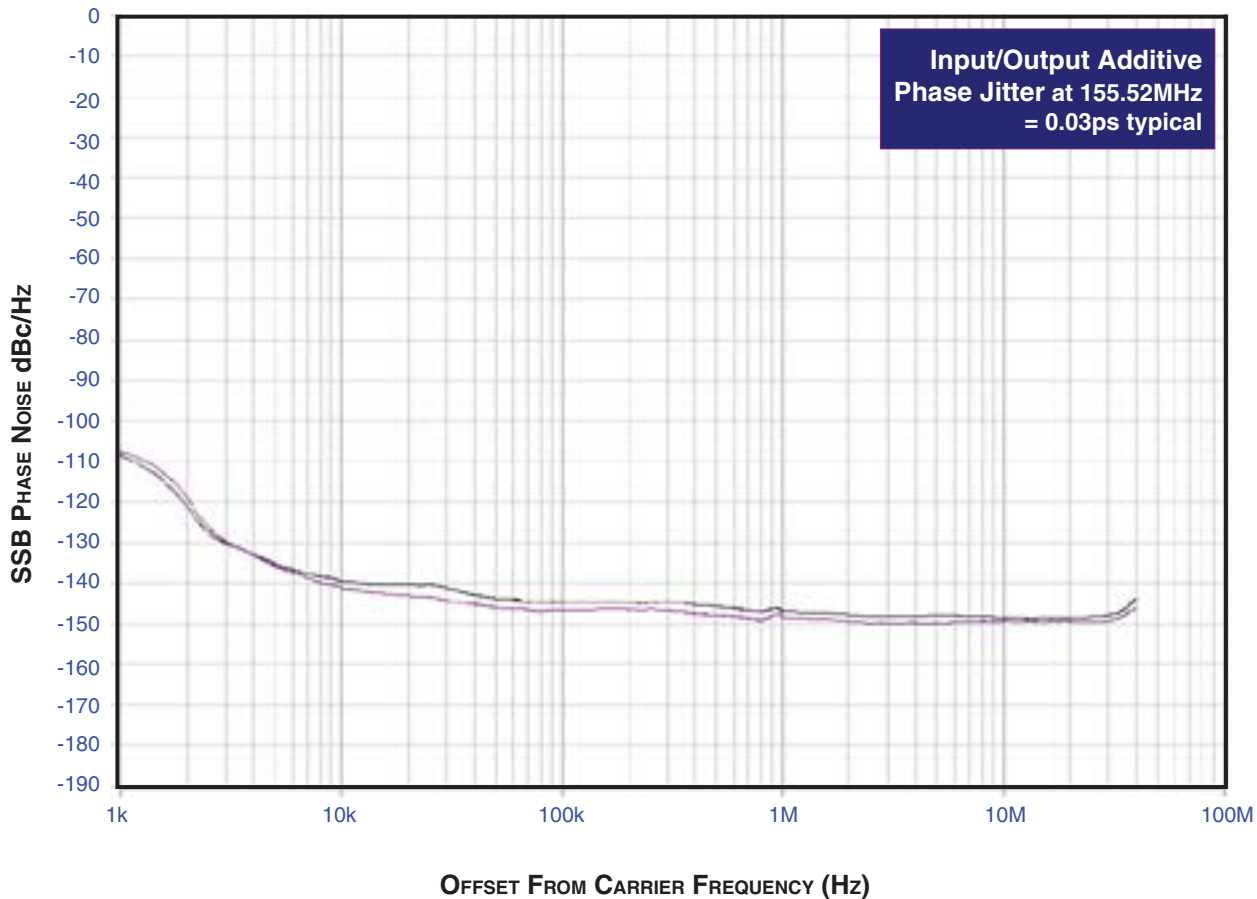

As with most timing specifications, phase noise measurements have issues. The primary issue relates to the limitations of the equipment. Often the noise floor of the equipment is higher than the noise floor of the device. This is illustrated above. The

device meets the noise floor of what is shown, but can actually be lower. The phase noise is dependant on the input source and measurement equipment.

# PARAMETER MEASUREMENT INFORMATION

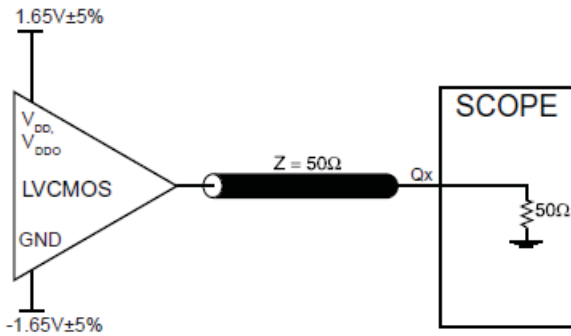
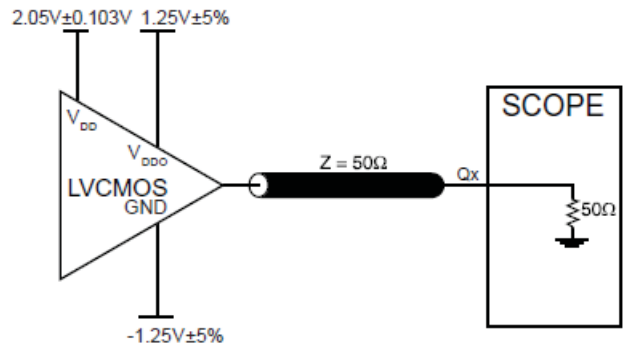
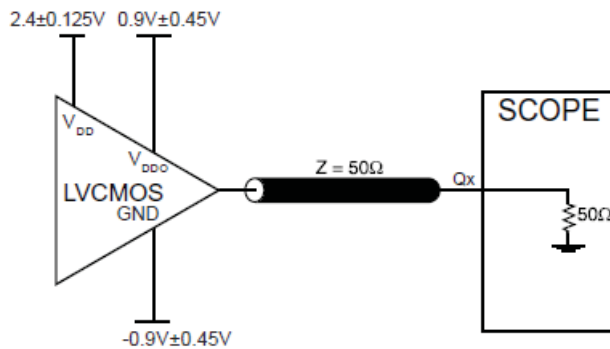
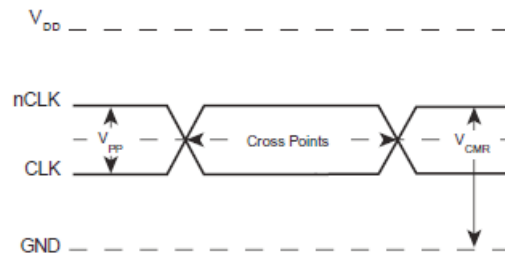
**3.3V CORE/3.3V OUTPUT LOAD AC TEST CIRCUIT**

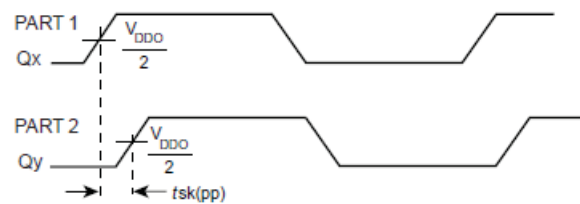
**3.3V CORE/2.5V OUTPUT LOAD AC TEST CIRCUIT**

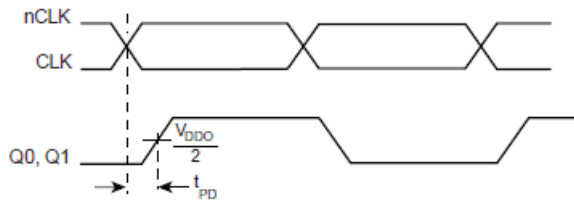
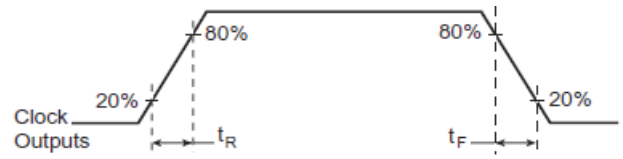
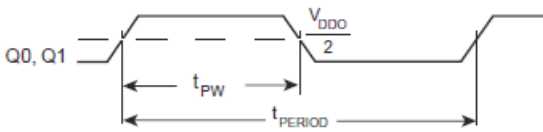
**3.3V CORE/1.8V OUTPUT LOAD AC TEST CIRCUIT**

**DIFFERENTIAL INPUT LEVEL**

**OUTPUT SKEW**

**PART-TO-PART SKEW**

**PROPAGATION DELAY**

**OUTPUT RISE/FALL TIME**

$$\text{odc} = \frac{t_{\text{PW}}}{t_{\text{PERIOD}}} \times 100\%$$

**OUTPUT DUTY CYCLE/PULSE WIDTH/PERIOD**



## APPLICATION INFORMATION

### WIRING THE DIFFERENTIAL INPUT TO ACCEPT SINGLE ENDED LEVELS

Figure 1 shows how the differential input can be wired to accept single ended levels. The reference voltage  $V_{REF} = V_{DD}/2$  is generated by the bias resistors R1, R2 and C1. This bias circuit should be located as close as possible to the input pin. The ratio

of R1 and R2 might need to be adjusted to position the  $V_{REF}$  in the center of the input voltage swing. For example, if the input clock swing is only 2.5V and  $V_{DD} = 3.3V$ ,  $V_{REF}$  should be 1.25V and  $R2/R1 = 0.609$ .

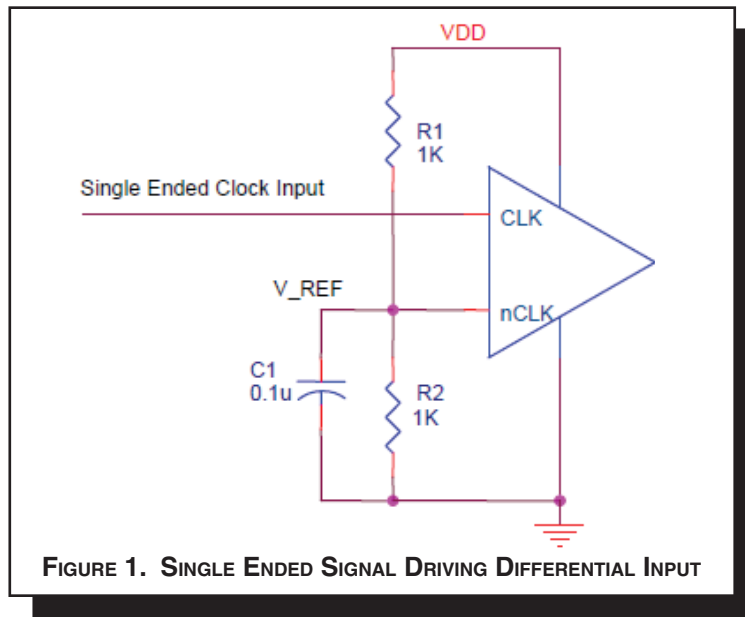

### RECOMMENDATIONS FOR UNUSED OUTPUT PINS

#### OUTPUTS:

##### LVC MOS OUTPUTS

All unused LVC MOS output can be left floating. We recommend that there is no trace attached.

## DIFFERENTIAL CLOCK INPUT INTERFACE

The CLK/nCLK accepts LVDS, LVPECL, LVHSTL, SSTL, HCSTL and other differential signals. Both  $V_{SWING}$  and  $V_{OH}$  must meet the  $V_{PP}$  and  $V_{CMR}$  input requirements. Figures 2A to 2E show interface examples for the CLK/nCLK input driven by the most common driver types. The input interfaces suggested here are

examples only. Please consult with the vendor of the driver component to confirm the driver termination requirements. For example in *Figure 2A*, the input termination applies for LVHSTL drivers. If you are using an LVHSTL driver from another vendor, use their termination recommendation.

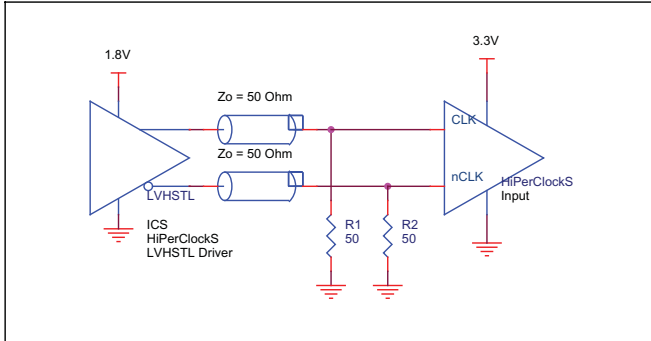

**FIGURE 2A. CLK/nCLK INPUT DRIVEN BY LVHSTL DRIVER**

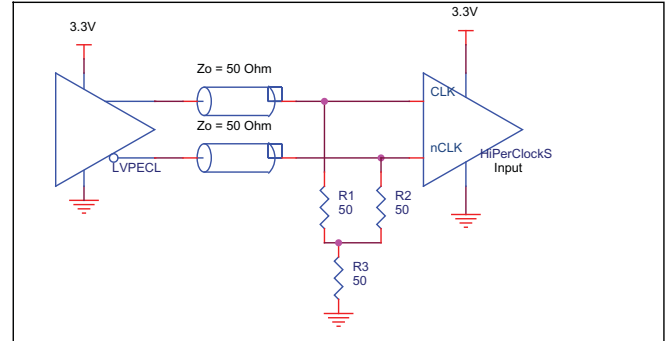

**FIGURE 2B. CLK/nCLK INPUT DRIVEN BY 3.3V LVPECL DRIVER**

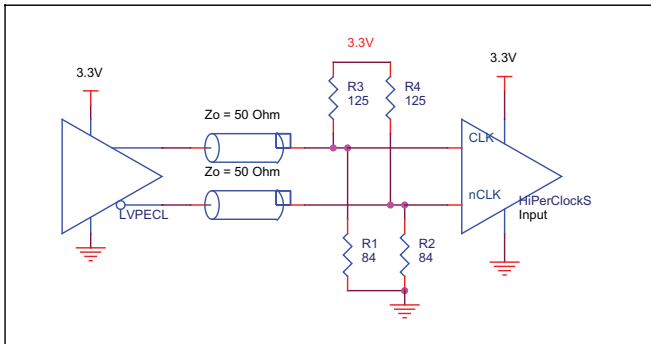

**FIGURE 2C. CLK/nCLK INPUT DRIVEN BY 3.3V LVPECL DRIVER**

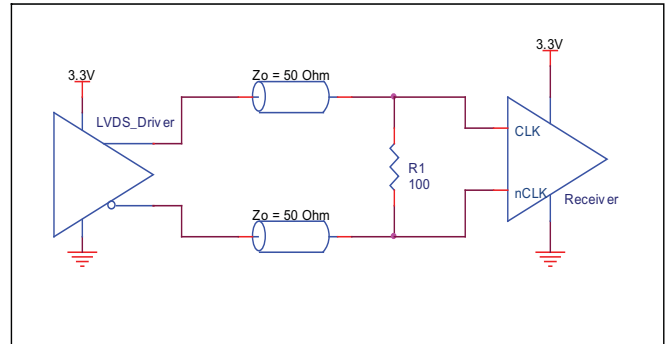

**FIGURE 2D. CLK/nCLK INPUT DRIVEN BY 3.3V LVDS DRIVER**

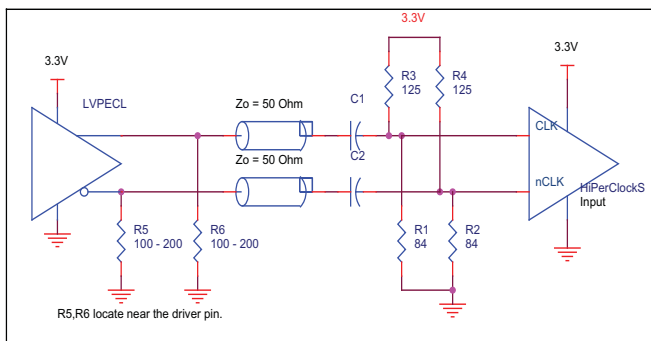

**FIGURE 2E. CLK/nCLK INPUT DRIVEN BY 3.3V LVPECL DRIVER WITH AC COUPLE**

## SCHEMATIC EXAMPLE

Figure 3 shows an application schematic example of 830261-01. The 830261-01 CLK/nCLK input can directly accept various types of differential signal. In this example, the input is driven by an LVDS driver. The 830261-01 outputs are LVC MOS drivers. In

this example, series termination approach is shown. Additional termination approaches are shown in the LVC MOS Termination Application Note.

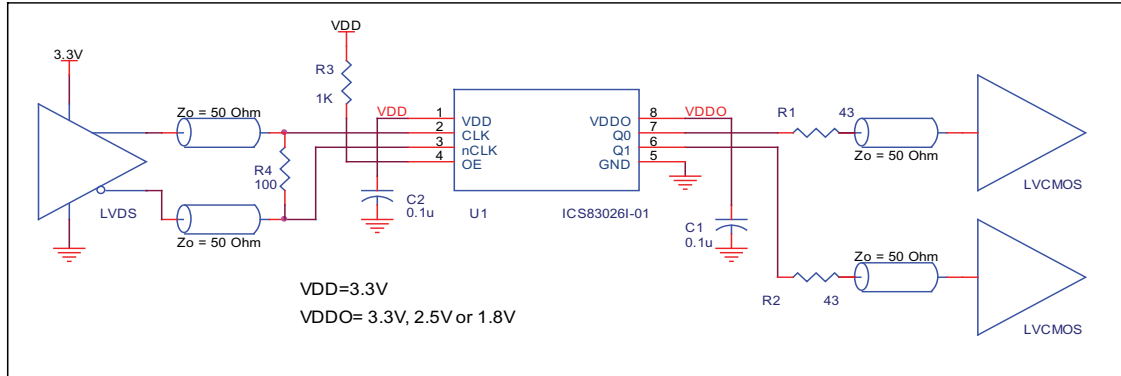

FIGURE 3. 830261-01 SCHEMATIC EXAMPLE

## RELIABILITY INFORMATION

TABLE 5A.  $\theta_{JA}$  VS. AIR FLOW TABLE FOR 8 LEAD SOIC

	$\theta_{JA}$ by Velocity (Linear Feet per Minute)		
	0	200	500
Single-Layer PCB, JEDEC Standard Test Boards	153.3°C/W	128.5°C/W	115.5°C/W
Multi-Layer PCB, JEDEC Standard Test Boards	112.7°C/W	103.3°C/W	97.1°C/W

**NOTE:** Most modern PCB designs use multi-layered boards. The data in the second row pertains to most designs.

TABLE 5B.  $\theta_{JA}$  VS. AIR FLOW TABLE FOR 8 LEAD TSSOP

	$\theta_{JA}$ by Velocity (Linear Feet per Minute)		
	0	200	500
Multi-Layer PCB, JEDEC Standard Test Boards	101.7°C/W	90.5°C/W	89.8°C/W

### TRANSISTOR COUNT

The transistor count for ICS830261-01 is: 260

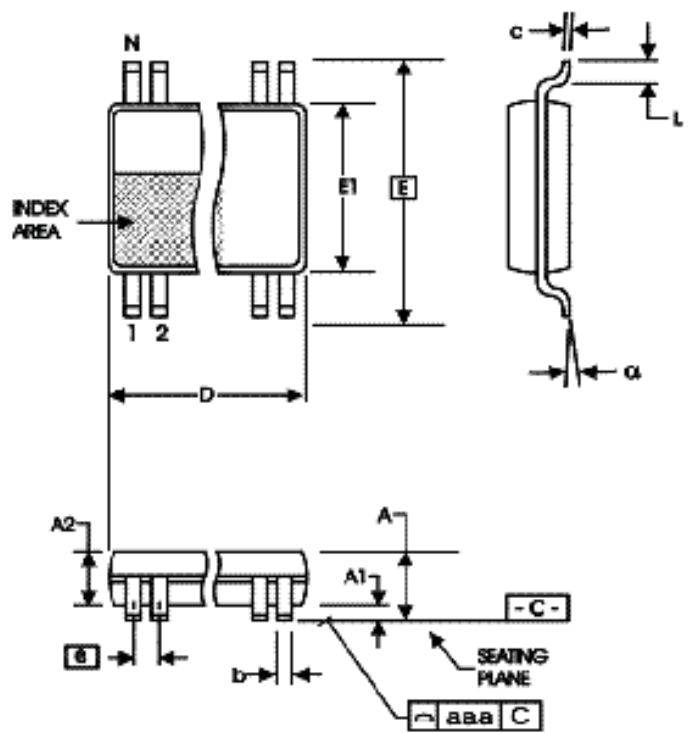
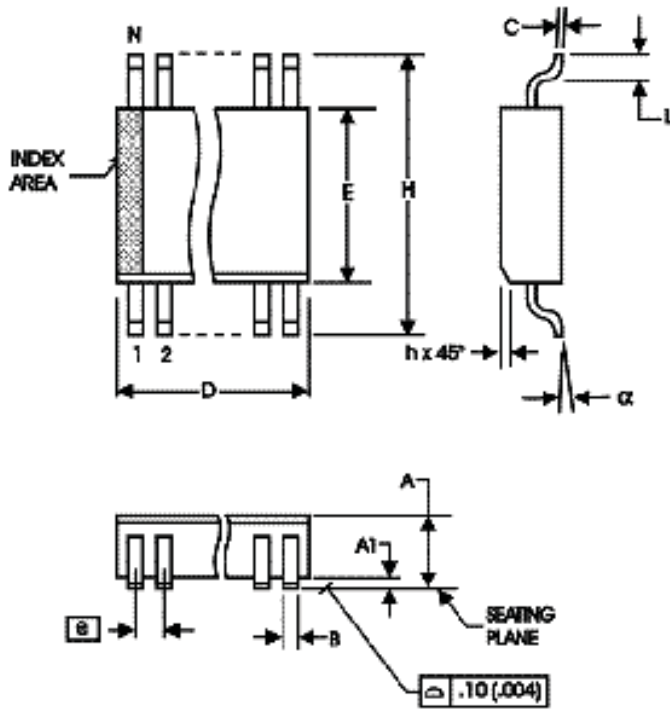
**PACKAGE OUTLINE - SUFFIX M FOR 8 LEAD SOIC**
**PACKAGE OUTLINE - G SUFFIX FOR 8 LEAD TSSOP**

**TABLE 6A. PACKAGE DIMENSIONS**

SYMBOL	Millimeters	
	MINIMUM	MAXIMUM
N	8	
A	1.35	1.75
A1	0.10	0.25
B	0.33	0.51
C	0.19	0.25
D	4.80	5.00
E	3.80	4.00
e	1.27 BASIC	
H	5.80	6.20
h	0.25	0.50
L	0.40	1.27
$\alpha$	0°	8°

Reference Document: JEDEC Publication 95, MS-012

**TABLE 6B. PACKAGE DIMENSIONS**

SYMBOL	Millimeters	
	Minimum	Maximum
N	8	
A	--	1.20
A1	0.05	0.15
A2	0.80	1.05
b	0.19	0.30
c	0.09	0.20
D	2.90	3.10
E	6.40 BASIC	
E1	4.30	4.50
e	0.65 BASIC	
L	0.45	0.75
$\alpha$	0°	8°
aaa	--	0.10

Reference Document: JEDEC Publication 95, MO-153

**TABLE 7. ORDERING INFORMATION**

Part/Order Number	Marking	Package	Shipping Packaging	Temperature
83026BMI-01LF	026BI01L	8 lead "Lead Free" SOIC	Tube	-40°C to +85°C
83026BMI-01LFT	026BI01L	8 lead "Lead Free" SOIC	Tape and Reel	-40°C to +85°C
83026BGI-01LF	BI01L	8 lead "Lead Free" TSSOP	Tube	-40°C to +85°C
83026BGI-01LFT	BI01L	8 lead "Lead Free" TSSOP	Tape and Reel	-40°C to +85°C

REVISION HISTORY SHEET				
Rev	Table	Page	Description of Change	Date
A	T7	1	Added 8 Lead TSSOP package to Pin Assignment.	6/25/04
		3	Absolute Maximum Ratings - added 8 Lead TSSOP to Package Thermal Impedance.	
		11	Added 8 Lead TSSOP Reliability Information table.	
		12	Added 8 Lead TSSOP Package Outline and Package Dimensions.	
		13	Ordering Information Table - added 8 Lead TSSOP ordering information.	
A		6	Additive Phase Jitter - corrected X axis on plot.	8/2/05
A	T3C	3	LVC MOS DC Characteristics - corrected Test Conditions for IIH and IIL.	8/12/05
A	T7	1	Features Section - added lead-free bullet	1/16/06
		9	Added Recommendations for Unused Output Pins.	
		13	Ordering Information Table - added lead-free part number, marking, and note.	
A	T7	13	Ordering Information Table - added lead-free marking	10/22/07
A	T7	13	Updated datasheet's header/footer with IDT from ICS.	8/4/10
		15	Removed ICS prefix from Part/Order Number column. Added Contact Page.	
A	T7	1	Removed the ICS prefix on part numbers.	12/15/15
		13	Features Section - removed reference to leaded packages. Ordering Information - removed 2500 from Tape and Reel. Removed LF note below the table. Updated datasheet header and footer	



Corporate Headquarters  
6024 Silver Creek Valley Road  
San Jose, CA 95138 USA  
[www.IDT.com](http://www.IDT.com)

Sales  
1-800-345-7015 or 408-284-8200  
Fax: 408-284-2775  
[www.IDT.com/go/sales](http://www.IDT.com/go/sales)

Tech Support  
[www.idt.com/go/support](http://www.idt.com/go/support)

DISCLAIMER Integrated Device Technology, Inc. (IDT) reserves the right to modify the products and/or specifications described herein at any time, without notice, at IDT's sole discretion. Performance specifications and operating parameters of the described products are determined in an independent state and are not guaranteed to perform the same way when installed in customer products. The information contained herein is provided without representation or warranty of any kind, whether express or implied, including, but not limited to, the suitability of IDT's products for any particular purpose, an implied warranty of merchantability, or non-infringement of the intellectual property rights of others. This document is presented only as a guide and does not convey any license under intellectual property rights of IDT or any third parties.

IDT's products are not intended for use in applications involving extreme environmental conditions or in life support systems or similar devices where the failure or malfunction of an IDT product can be reasonably expected to significantly affect the health or safety of users. Anyone using an IDT product in such a manner does so at their own risk, absent an express, written agreement by IDT.

Integrated Device Technology, IDT and the IDT logo are trademarks or registered trademarks of IDT and its subsidiaries in the United States and other countries. Other trademarks used herein are the property of IDT or their respective third party owners.

For datasheet type definitions and a glossary of common terms, visit [www.idt.com/go/glossary](http://www.idt.com/go/glossary).

Copyright ©2015 Integrated Device Technology, Inc. All rights reserved.



Компания «ЭлектроПласт» предлагает заключение долгосрочных отношений при поставках импортных электронных компонентов на взаимовыгодных условиях!

Наши преимущества:

- Оперативные поставки широкого спектра электронных компонентов отечественного и импортного производства напрямую от производителей и с крупнейших мировых складов;
- Поставка более 17-ти миллионов наименований электронных компонентов;
- Поставка сложных, дефицитных, либо снятых с производства позиций;
- Оперативные сроки поставки под заказ (от 5 рабочих дней);
- Экспресс доставка в любую точку России;
- Техническая поддержка проекта, помощь в подборе аналогов, поставка прототипов;
- Система менеджмента качества сертифицирована по Международному стандарту ISO 9001;
- Лицензия ФСБ на осуществление работ с использованием сведений, составляющих государственную тайну;
- Поставка специализированных компонентов (Xilinx, Altera, Analog Devices, Intersil, Interpoint, Microsemi, Aeroflex, Peregrine, Syfer, Eurofarad, Texas Instrument, Miteq, Cobham, E2V, MA-COM, Hittite, Mini-Circuits, General Dynamics и др.);

Помимо этого, одним из направлений компании «ЭлектроПласт» является направление «Источники питания». Мы предлагаем Вам помощь Конструкторского отдела:

- Подбор оптимального решения, техническое обоснование при выборе компонента;
- Подбор аналогов;
- Консультации по применению компонента;
- Поставка образцов и прототипов;
- Техническая поддержка проекта;
- Защита от снятия компонента с производства.



#### Как с нами связаться

**Телефон:** 8 (812) 309 58 32 (многоканальный)

**Факс:** 8 (812) 320-02-42

**Электронная почта:** [org@eplast1.ru](mailto:org@eplast1.ru)

**Адрес:** 198099, г. Санкт-Петербург, ул. Калинина, дом 2, корпус 4, литера А.