



Features

- Single Supply Voltage 3.0V to 5.0V
- Two Mode Operation
- 29 dB Typical Gain Across Band
- P_{OUT}: 18 dBm at 3.3V Typ.
P_{OUT}: 21 dBm at 5V Typ.
- Integrated Second and Third Harmonic Filter

Applications

- IEEE802.11a/n and IEEE802.16e Applications
- HyperLAN
- WiFi Systems
- Commercial and Consumer Systems
- Portable Battery-Powered Equipment
- Spread-Spectrum and MMDS Systems

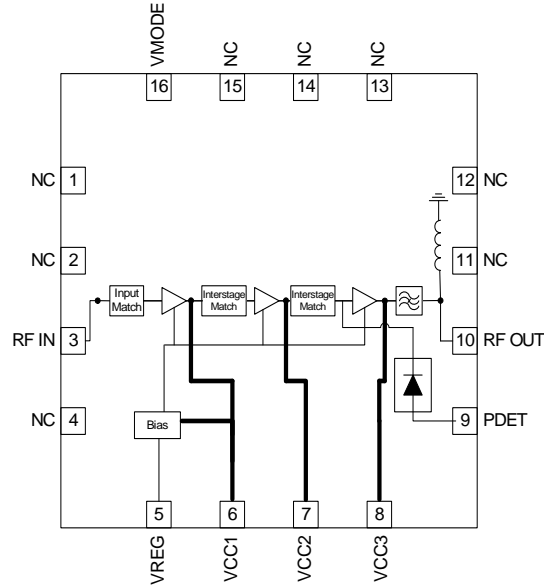

Functional Block Diagram

Product Description

The RF5616 is a linear, medium-power, high-efficiency power amplifier IC designed specifically for battery-powered WiFi applications such as PC cards, mini PCI, and compact flash applications. It is also designed to meet IEEE802.11a, IEEE802.11n, IEEE802.16e (4.9GHz to 5.850GHz only) WiMax, FCC, and ETSI requirements for operation in the 4.9GHz to 5.850GHz band. The device is manufactured on an advanced InGaP GaAs Heterojunction Bipolar Transistor process, and has been designed for use as the final RF amplifier in 5GHz WiFi and other spread-spectrum transmitters. The device is provided in a QFN, 16-pin, 3mmx3mmx0.45mm, leadless chip carrier with backside ground. The RF5616 operates from a single supply and will be easily incorporated into WiFi and other designs with minimal external components.

Ordering Information

RF5616SQ	Standard 25 piece bag
RF5616SR	Standard 100 piece reel
RF5616TR7	Standard 2500 piece reel
RF5616PCK-410	Fully Assembled Evaluation Board with 5-piece Loose Sample Bag

Optimum Technology Matching® Applied

- | | | | |
|---|--------------------------------------|-------------------------------------|------------------------------------|
| <input type="checkbox"/> GaAs HBT | <input type="checkbox"/> SiGe BiCMOS | <input type="checkbox"/> GaAs pHEMT | <input type="checkbox"/> GaN HEMT |
| <input type="checkbox"/> GaAs MESFET | <input type="checkbox"/> Si BiCMOS | <input type="checkbox"/> Si CMOS | <input type="checkbox"/> BiFET HBT |
| <input checked="" type="checkbox"/> InGaP HBT | <input type="checkbox"/> SiGe HBT | <input type="checkbox"/> Si BJT | <input type="checkbox"/> LD MOS |

RF MICRO DEVICES®, RFMD®, Optimum Technology Matching®, Enabling Wireless Connectivity™, PowerStar®, POLARIS™ TOTAL RADIO™ and UltimateBlue™ are trademarks of RFMD, LLC. BLUETOOTH is a trademark owned by Bluetooth SIG, Inc., U.S.A. and licensed for use by RFMD. All other trade names, trademarks and registered trademarks are the property of their respective owners. ©2006, RF Micro Devices, Inc.

Absolute Maximum Ratings

Parameter	Rating	Unit
Supply Voltage, RF applied	-0.5 to +5.25	V _{DC}
Supply Voltage, no RF applied	-0.5 to +6.0	V _{DC}
Power Control Voltage (V _{REG})	-0.5 to 3.5	V
DC Supply Current	400	mA
Input RF Power (50Ω load)	+5	dBm
Operating Ambient Temperature	-40 to +85	°C
Storage Temperature	-40 to +150	°C
Moisture sensitivity	JEDEC Level 1	



Caution! ESD sensitive device.

Exceeding any one or a combination of the Absolute Maximum Rating conditions may cause permanent damage to the device. Extended application of Absolute Maximum Rating conditions to the device may reduce device reliability. Specified typical performance or functional operation of the device under Absolute Maximum Rating conditions is not implied.

The information in this publication is believed to be accurate and reliable. However, no responsibility is assumed by RF Micro Devices, Inc. ("RFMD") for its use, nor for any infringement of patents, or other rights of third parties, resulting from its use. No license is granted by implication or otherwise under any patent or patent rights of RFMD. RFMD reserves the right to change component circuitry, recommended application circuitry and specifications at any time without prior notice.



RFMD Green: RoHS compliant per EU Directive 2011/65/EU, halogen free per IEC 61249-2-21, < 1000ppm each of antimony trioxide in polymeric materials and red phosphorus as a flame retardant, and <2% antimony in solder.

Nominal Operating Parameters

Parameter	Specification			Unit	Condition
	Min.	Typ.	Max.		
Compliance					T = +25 °C; V _{CC} = 3.3V and 5.0V; V _{REG} = 2.85V; pulsed at 1% to 100% duty cycle; Freq = 4.9GHz to 5.85GHz; unless otherwise noted. IEEE802.11a; IEEE802.11n; IEEE802.16e (4.9GHz to 5.85GHz)
Frequency Range	4.9		5.85	MHz	Lower, middle, upper U-NII
Output Power (Mode1)	17	18		dBm	V _{CC} = 3.3V, V _{MODE} = Low, using a standard IEEE802.11a waveform, 54 Mbps, 64QAM
EVM		3	4	%	RMS, mean at rated P _{OUT} , V _{CC} = 3.3V, V _{REG} = 2.85V and temperature = -40 °C to +85 °C
Output Power (Mode1)	19	20		dBm	V _{CC} = 5.0V, V _{MODE} = Low, using a standard IEEE802.11a waveform, 54 Mbps, 64QAM, 4.9GHz to 5.15 GHz
EVM		3	4	%	RMS, mean at rated P _{OUT} , V _{CC} = 5.0V, V _{REG} = 2.85V and temperature = -40 °C to +85 °C, 4.9GHz to 5.15 GHz
Output Power (Mode1)	20	21		dBm	V _{CC} = 5.0V, V _{MODE} = Low, using a standard IEEE802.11a waveform, 54 Mbps, 64QAM, 5.15GHz to 5.85 GHz
EVM		3	4	%	RMS, mean at rated P _{OUT} , V _{CC} = 5.0V, V _{REG} = 2.85V and temperature = -40 °C to +85 °C, 5.15GHz to 5.85 GHz
Large Signal Gain					At rated P _{OUT}
	25	29		dB	4.9GHz to 5.15GHz
	27	30		dB	5.15GHz to 5.85GHz
Gain Variation			2.5	±dB	4.9GHz to 5.85GHz, -40 °C to +85 °C
Power Detector					
P _{OUT} at 8dBm	0.3	0.4	0.5	V	Over full frequency range, -40 °C to +85 °C, V _{CC} = ON, and over full V _{REG} range
P _{OUT} at 21dBm	0.85	1.0	1.2	V	Over full frequency range, -40 °C to +85 °C, V _{CC} = ON, and over full V _{REG} range
Input Return Loss		-15	-7.0	dB	4.9GHz to 5.1GHz
		-15	-9.0	dB	5.1GHz to 5.85GHz
Turn On/OFF		0.5	1.0	μS	Output stable to within 90% of the final gain
Output VSWR			4:1		Stable and no spurs above -47 dBm/MHz

Parameter	Specification			Unit	Condition
	Min.	Typ.	Max.		
Second Harmonic		-30	-27	dBm/MHz	CF=4.9GHz to 5.299GHz, at rated power, V _{CC} =On, over V _{REG} range, and over -40°C to +85°C. measured in a 1MHz RBW with 6Mbps 11a signal.
		-50	-45	dBm/MHz	CF=5.3GHz to 5.85GHz, at rated power, V _{CC} =On, over V _{REG} range, and over -40°C to +85°C. Measured in a 1MHz RBW with 6Mbps 11a signal.
Third Harmonic		-38	-27	dBm/MHz	CF=4.9GHz to 5.15GHz and 5.32GHz to 5.85GHz, at rated power, V _{CC} =On, over full V _{REG} range and over -40°C to +85°C. Measured in a 1MHz RBW with 6Mbps 11a signal.
		-40	-38	dBm/MHz	CF=5.15GHz to 5.32GHz at rated power, V _{CC} =on, over full V _{REG} range and over -40°C to +85°C. Measured in a 1MHz RBW with 6Mbps 11a signal.
Operating Current		250	310	mA	V _{CC} =5.0V, V _{MODE} =Low, P _{OUT} =21dBm, over full V _{REG} and temperature=-40°C to +85°C
Quiescent Current		165	180	mA	V _{CC} =5.0V, V _{MODE} =Low, RF=OFF, over full V _{REG} and temperature=-40°C to +85°C
Operating Current		200	240	mA	V _{CC} =3.3V, V _{MODE} =Low, P _{OUT} =18dBm, over full V _{REG} and temperature=-40°C to +85°C
Quiescent Current		140	160	mA	V _{CC} =3.3V, V _{MODE} =Low, RF=OFF, over full V _{REG} and temperature=-40°C to +85°C
I _{REG}		10	15	mA	V _{CC} =ON, over full V _{REG} range and temperature -40°C to +85°C
Leakage (Shutdown) Current		0.5	2.5	μA	V _{CC} =ON, over full V _{REG} range and temperature -40°C to +85°C
Output Power (Mode 2)	8	9		dBm	V _{CC} =ON, V _{MODE} =High, using a standard IEEE802.11a waveform, 54Mbps, 64QAM
EVM		3	4	%	RMS, mean, 54Mbps at rated power (Mode 2), V _{CC} =ON, V _{REG} =2.85V, V _{MODE} =High, temperature=-40°C to +85°C
Gain	24	26		dB	4.9GHz to 5.15GHz
	25	27		dB	5.15GHz to 5.85GHz
Gain Variation			2.5	±dB	4.9GHz to 5.85GHz, -40°C to +85°C
Operating Current		120	150	mA	V _{CC} =ON, V _{MODE} =High, at rated power, temperature=-40°C to +85°C
Quiescent Current		100	120	mA	V _{CC} =ON, V _{MODE} =High, RF=OFF, temperature=-40°C to +85°C
I _{REG}		12	17	mA	V _{CC} =ON, V _{MODE} =High, over full V _{REG} range, at rated power and temperature=-40°C to +85°C
Voltage Supply (V _{CC})	3.0	3.3	5.0	V	
V _{REG} supply	2.75	2.85	2.95	V	
V _{MODE}	2.75	3.3	5.0	V	
V _{MODE} Current		100	500	μA	

Pin Names and Descriptions

Pin	Name	Description
1, 2, 4, 11, 12, 13, 14, 15	N/C	Not internally connected.
3	RFIN	RF Input Pin, Internally matched to 50Ω and DC blocked.
5	VREG	First, second, and third stage bias voltage combined on the die to one external voltage. This Pin requires regulated supply for best performance.
6, 7, 8	VCC	Supply voltage for the PA. Internally decoupled with approximately 100pF.
9	PDETECT	Power detector voltage is proportional to RF output power. May need external decoupling capacitor for module stability. May need external circuitry to bring output voltage to desired level.
10	RF OUT	RF output pin. This pin is matched to 50Ω internally. This pin has a DC blocking cap from the collector side of the final stage but it is an RF short at the RF OUT Pins 10 and 12 therefore an external DC blocking capacitor is needed if DC voltage is presented to the RF OUT pins. See functional block diagram on the first page for more details.
16	VMODE	This pin will allow the power amplifier to switch between two modes. The first mode is the mode 1, in which this pin needs to be logic low or floating. The second mode is mode 2 which allows the power amplifier to be in a low current and this pin needs to be logic high.
Pkg Base	GND	Ground connection.

Package Drawing

QFN, 16-Pin, 3x3x0.45mm

NOTES:

- 1 DIMENSION APPLIES TO METALLIZED TERMINAL AND IS MEASURED BETWEEN 0.25mm AND 0.30mm FROM TERMINAL TIP.
- 2 DIMENSION REPRESENTS TERMINAL PULL BACK FROM PACKAGE EDGE UP TO 0.1mm IS ACCEPTABLE.
- 3 COPLANARITY APPLIES TO THE EXPOSED HEAT SLUG AS WELL AS THE TERMINAL.
- 4 RADIUS ON TERMINALS IS OPTIONAL.

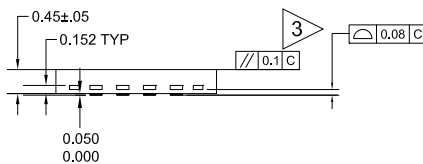
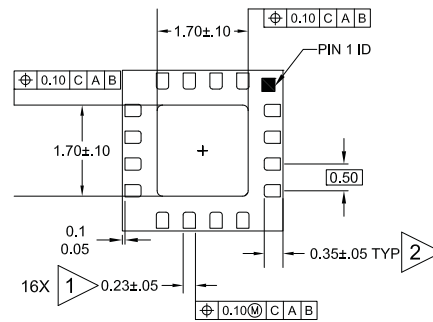
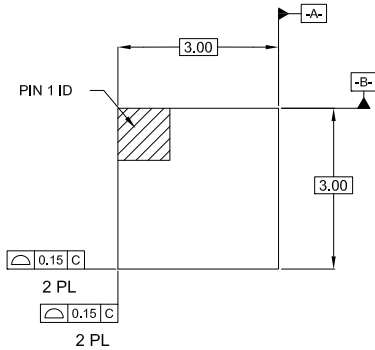

Pin Out

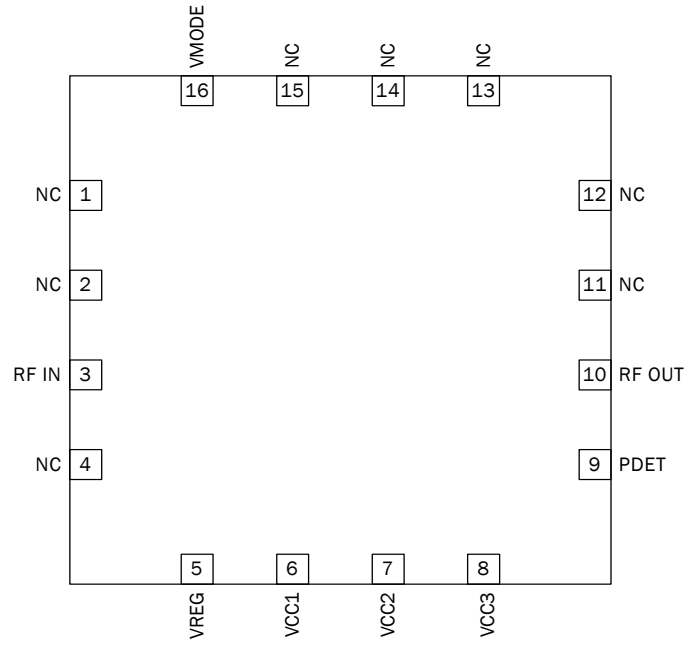

PCB Design Requirements

PCB Surface Finish

The PCB surface finish used for RFMD's qualification process is electroless nickel, immersion gold. Typical thickness is 3 micro-inch to 8 micro-inch gold over 180 micro-inch nickel.

PCB Land Pattern Recommendation *

PCB land patterns for RFMD components are based on IPC-7351 standards and RFMD empirical data. The pad pattern shown has been developed and tested for optimized assembly at RFMD. The PCB land pattern has been developed to accommodate lead and package tolerances. Since surface mount processes vary from company to company, careful process development is recommended.

PCB Metal Land Pattern

A = 0.230 x 0.360 (mm) Typ
 B = 0.360 x 0.230 (mm) Typ
 C = 1.700 (mm) Sq

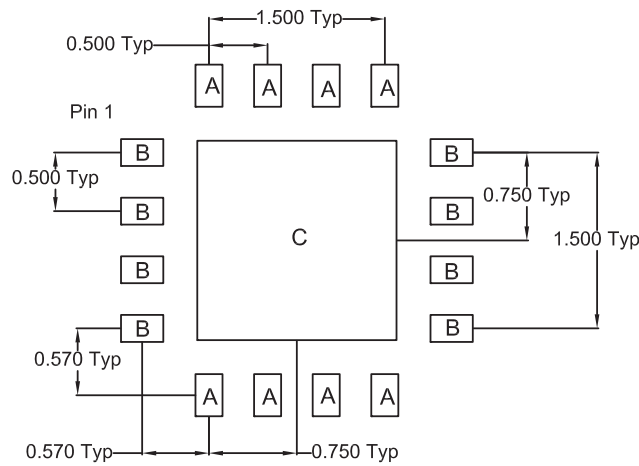

PCB Solder Mask Pattern

Liquid Photo-Imageable (LPI) solder mask is recommended. The solder mask footprint will match what is shown for the PCB metal land pattern with a 2 mil to 3 mil expansion to accommodate solder mask registration clearance around all pads. The center-grounding pad shall also have a solder mask clearance. Expansion of the pads to create solder mask clearance can be provided in the master data or requested from the PCB fabrication supplier.

- A = 0.38 x 0.51 (mm) Typ
- B = 0.51 x 0.38 (mm) Typ
- C = 1.85 (mm) Sq

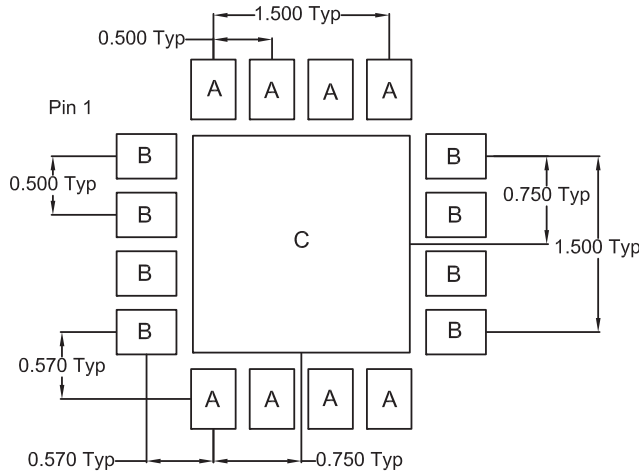

Thermal Pad and Via Design

The PCB land pattern has been designed with a thermal pad that matches the die paddle size on the bottom of the device.

Thermal vias are required in the PCB layout to effectively conduct heat away from the package. The via pattern has been designed to address thermal, power dissipation and electrical requirements of the device as well as accommodating routing strategies.

The via pattern used for the RFMD qualification is based on thru-hole vias with 0.203mm to 0.330mm finished hole size on a 0.5mm to 1.2mm grid pattern with 0.025mm plating on via walls. If micro vias are used in a design, it is suggested that the quantity of vias be increased by a 4:1 ratio to achieve similar results.

Evaluation Board Schematic RF5616PCBA Evaluation Board (4.9 GHz to 5.85 GHz)

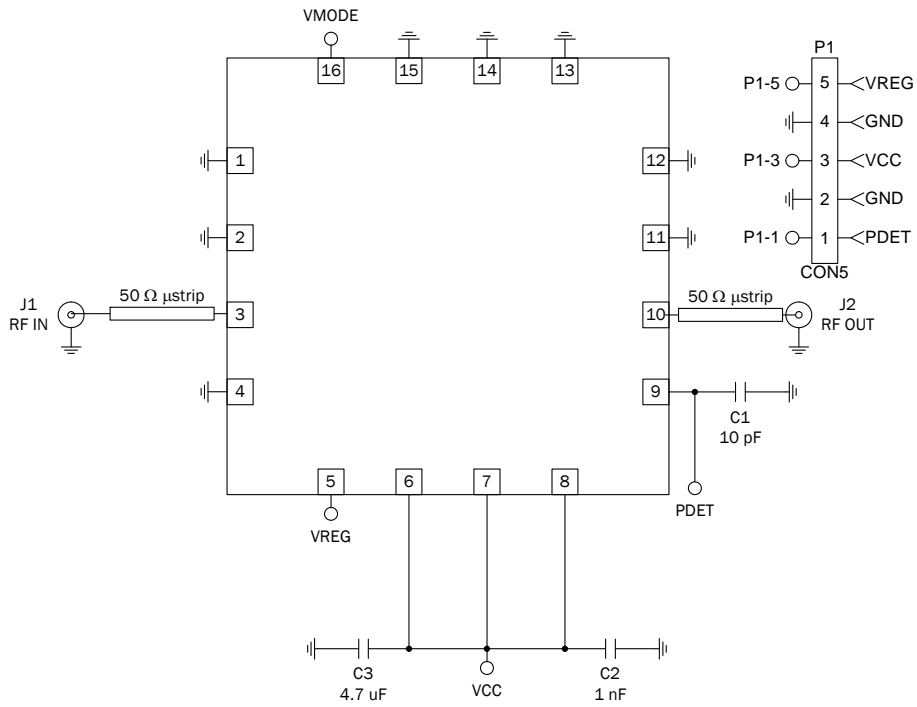

Evaluation Board Layout

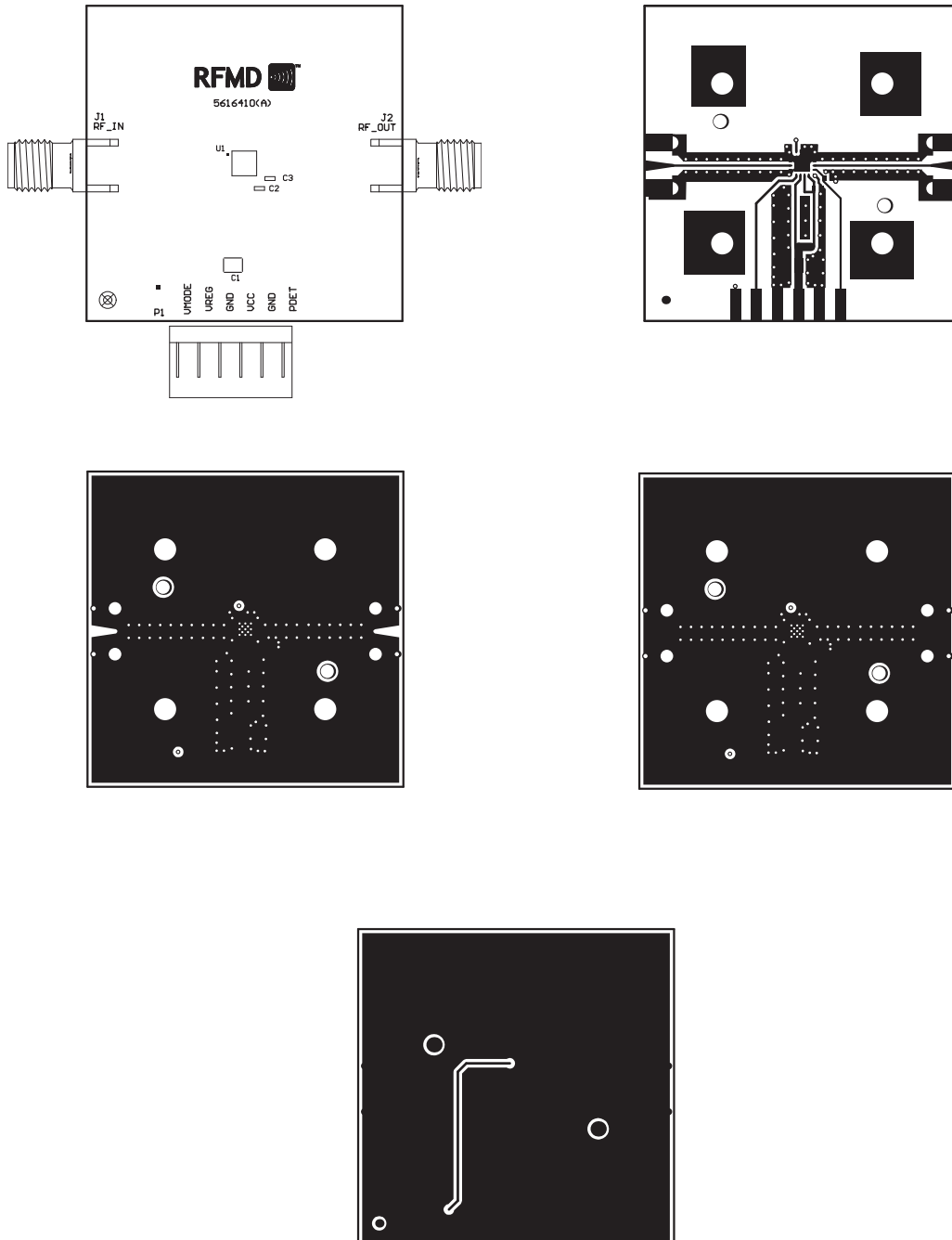

Typical EVM versus P_{OUT}
($V_{CC} = 3.3V, V_{REG} = 2.85V$)

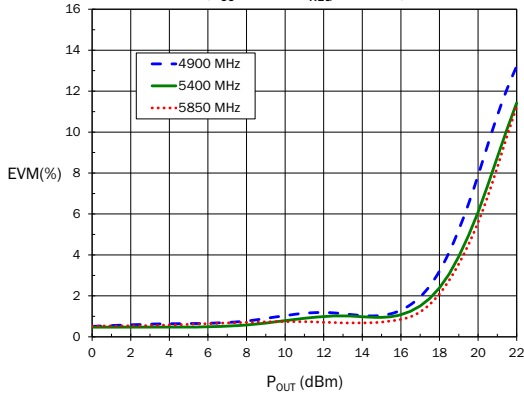

Typical EVM versus P_{OUT} over Temperature -40 TO +85C
($V_{CC} = 3.3V, V_{REG} = 2.85V$)

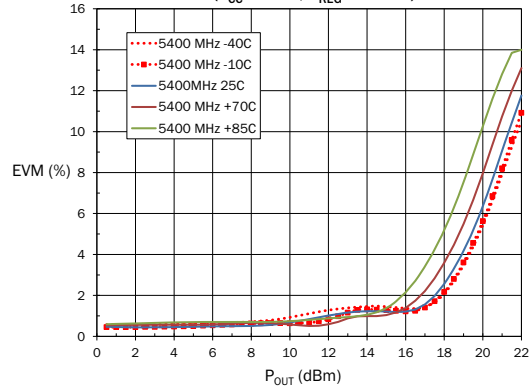

Typical Gain versus P_{OUT}
($V_{CC} = 3.3V, V_{REG} = 2.85V$)

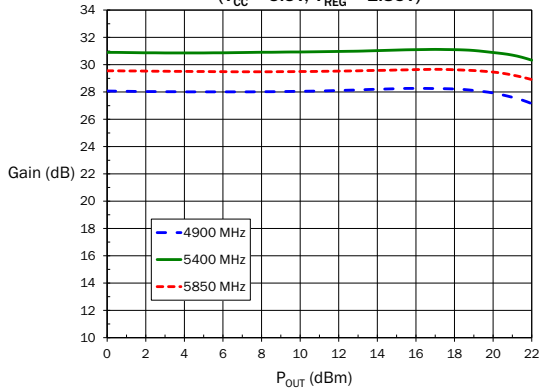

Typical Gain @ 5400MHz versus P_{OUT} over Temp (-40 to +85C)
($V_{CC} = 3.3V, V_{REG} = 2.85V$)

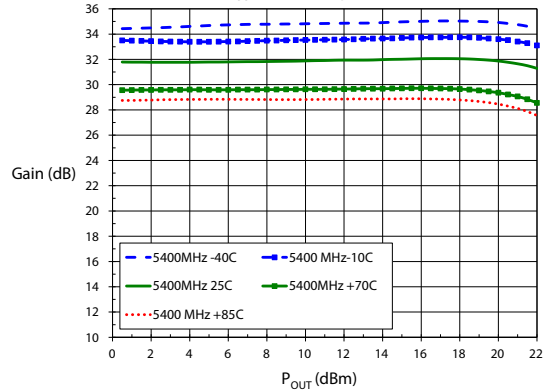

Typical I_{CC} versus P_{OUT}
($V_{CC} = 3.3V, V_{REG} = 2.85V$)

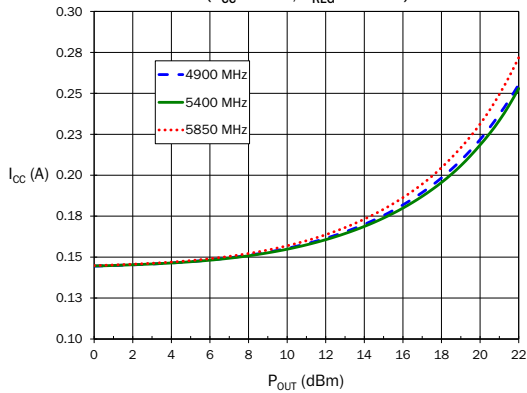

Typical I_{CC} versus P_{OUT} over Temp (-40 to +85C)
($V_{CC} = 3.3V, V_{REG} = 2.85V$)

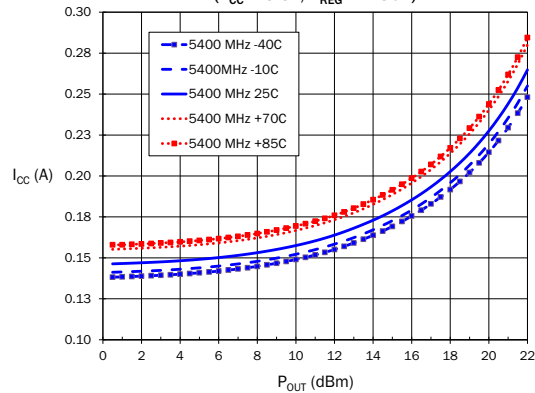

Typical P_{DET} versus P_{OUT}
($V_{CC} = 3.3V, V_{REG} = 2.85V$)

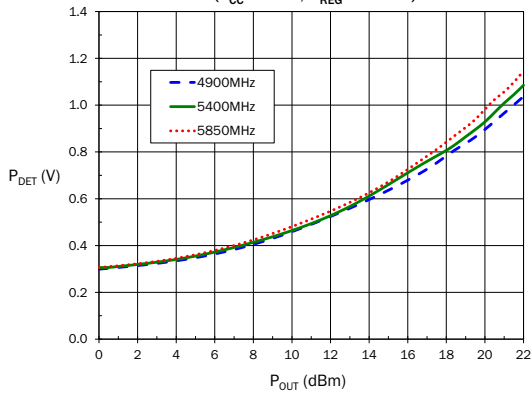

Typical P_{DET} versus P_{OUT} over Temp(-40 to +85C)
($V_{CC} = 3.3V, V_{REG} = 2.85V$)

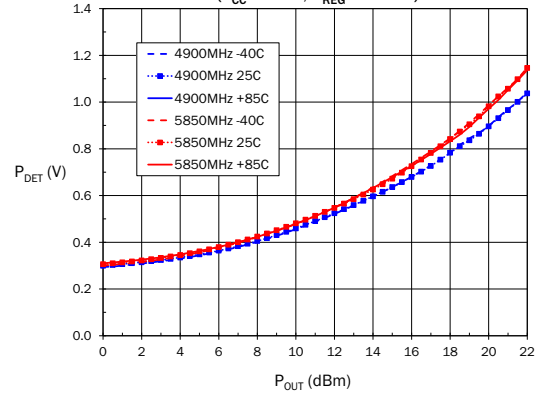

Typical I_{REG} versus P_{OUT}
($V_{CC} = 3.3V, V_{REG} = 2.85V$)

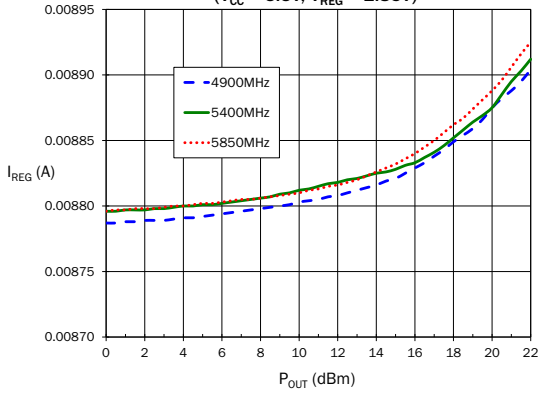

Typical I_{REG} versus P_{OUT} over Temp (-40 to +85C)
($V_{CC} = 3.3V, V_{REG} = 2.85V$)

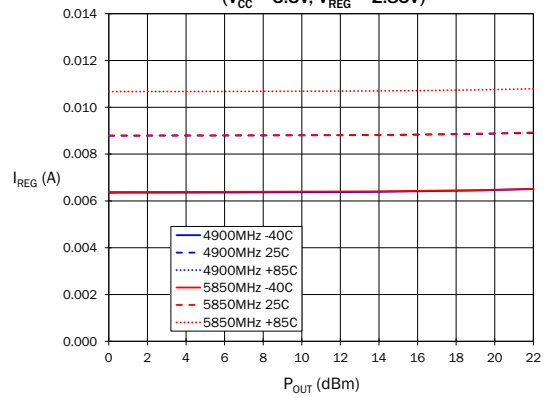

Typical S11, S21, and S22
($V_{CC} = 3.3V, V_{REG} = 2.85V, V_{MODE} = 0V$ at 25°C)

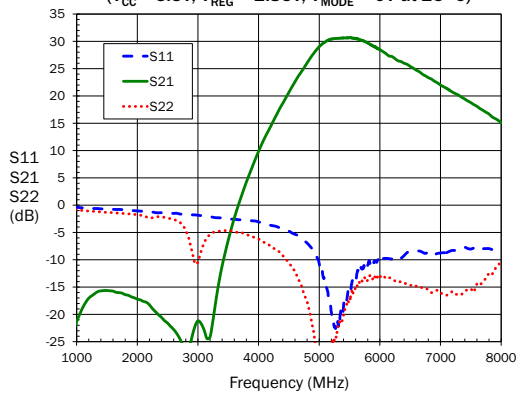

Typical S11, S21, and S22
($V_{CC} = 3.3V, V_{REG} = 2.85V, V_{MODE} = 3.3V$ at 25°C)

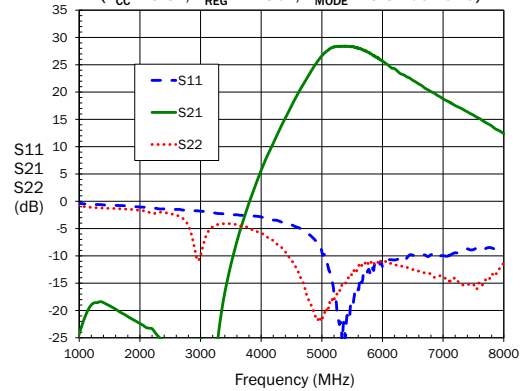

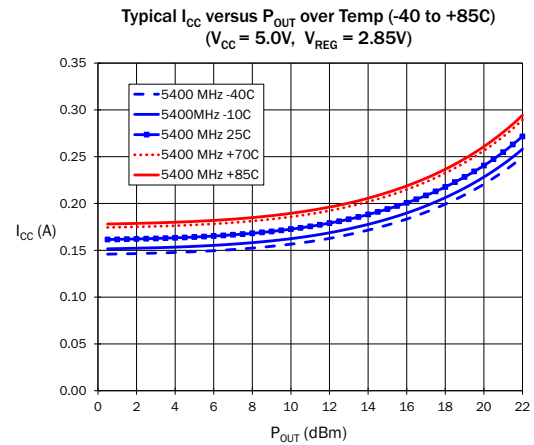
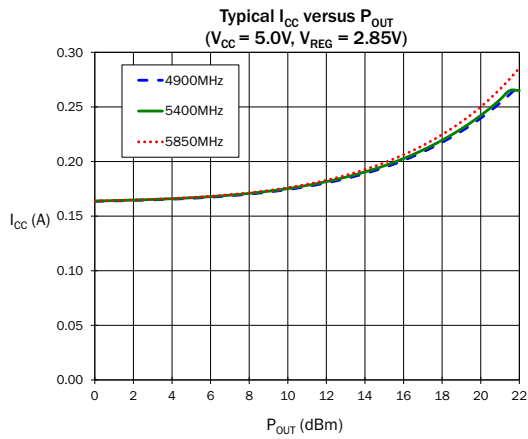
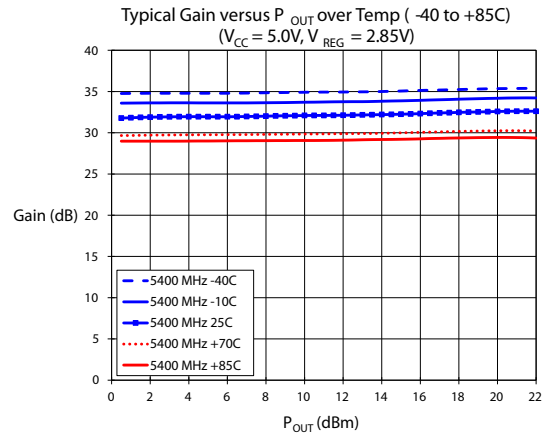
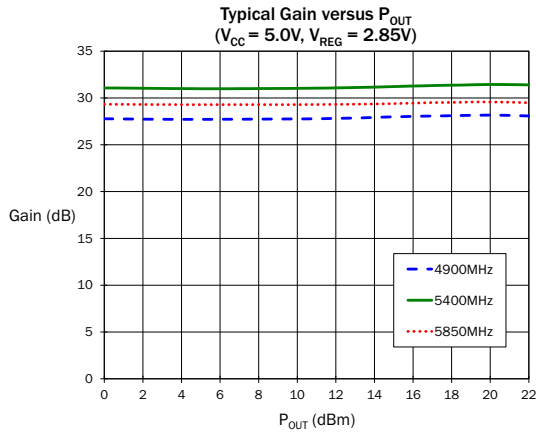
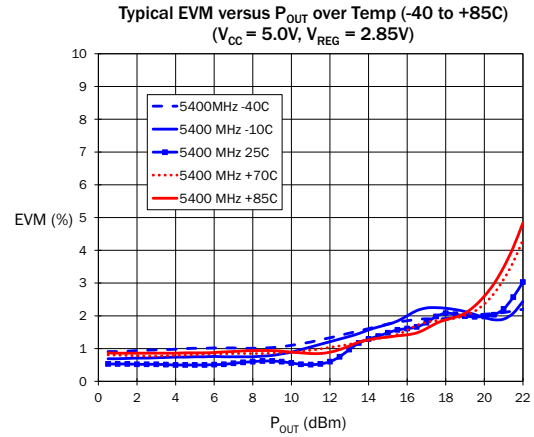
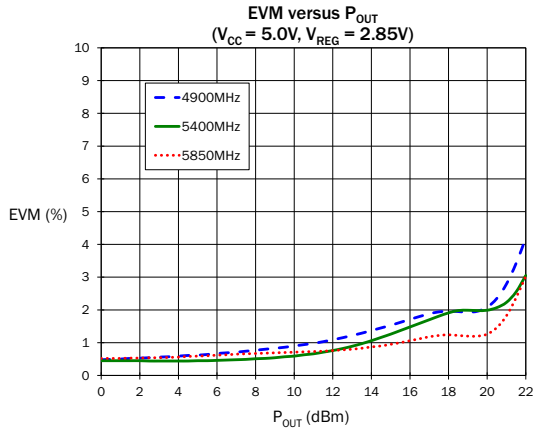

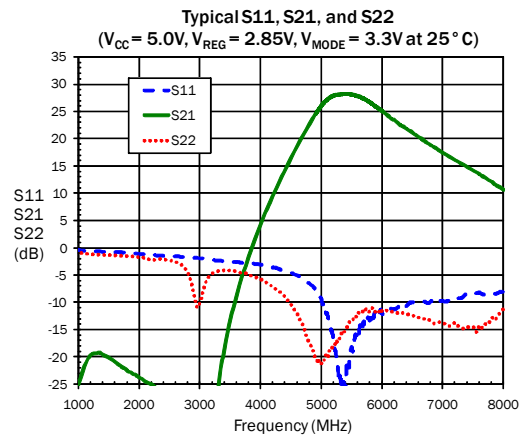
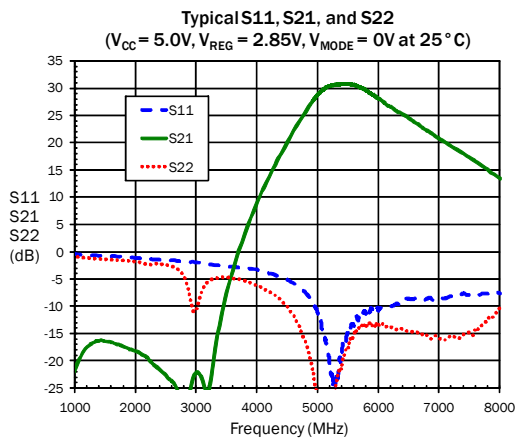
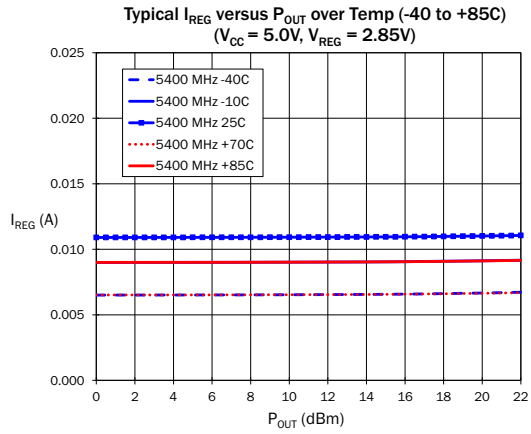
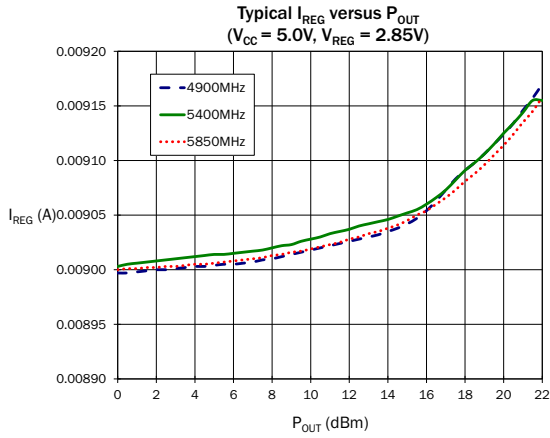
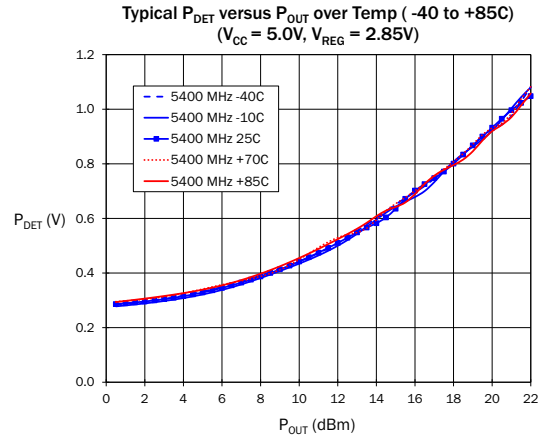
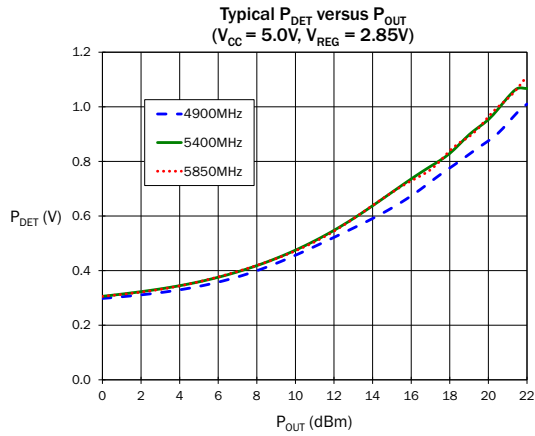



Компания «ЭлектроПласт» предлагает заключение долгосрочных отношений при поставках импортных электронных компонентов на взаимовыгодных условиях!

Наши преимущества:

- Оперативные поставки широкого спектра электронных компонентов отечественного и импортного производства напрямую от производителей и с крупнейших мировых складов;
- Поставка более 17-ти миллионов наименований электронных компонентов;
- Поставка сложных, дефицитных, либо снятых с производства позиций;
- Оперативные сроки поставки под заказ (от 5 рабочих дней);
- Экспресс доставка в любую точку России;
- Техническая поддержка проекта, помощь в подборе аналогов, поставка прототипов;
- Система менеджмента качества сертифицирована по Международному стандарту ISO 9001;
- Лицензия ФСБ на осуществление работ с использованием сведений, составляющих государственную тайну;
- Поставка специализированных компонентов (Xilinx, Altera, Analog Devices, Intersil, Interpoint, Microsemi, Aeroflex, Peregrine, Syfer, Eurofarad, Texas Instrument, Miteq, Cobham, E2V, MA-COM, Hittite, Mini-Circuits, General Dynamics и др.);

Помимо этого, одним из направлений компании «ЭлектроПласт» является направление «Источники питания». Мы предлагаем Вам помощь Конструкторского отдела:

- Подбор оптимального решения, техническое обоснование при выборе компонента;
- Подбор аналогов;
- Консультации по применению компонента;
- Поставка образцов и прототипов;
- Техническая поддержка проекта;
- Защита от снятия компонента с производства.



Как с нами связаться

Телефон: 8 (812) 309 58 32 (многоканальный)

Факс: 8 (812) 320-02-42

Электронная почта: org@eplast1.ru

Адрес: 198099, г. Санкт-Петербург, ул. Калинина, дом 2, корпус 4, литера А.