

DC-DC Converter Specification

MYLPW3R34EAFN

1. Application

This specification applies to DC-DC Converter MYLPW3R34EAFN for telecommunication / data-communication equipment. For any other application, please contact us before using this product.

2. Customer Reference

Customer Spec. Number
Customer Part Number

3. Murata Part Number MYLPW3R34EAFN

4. Appearance, Dimensions

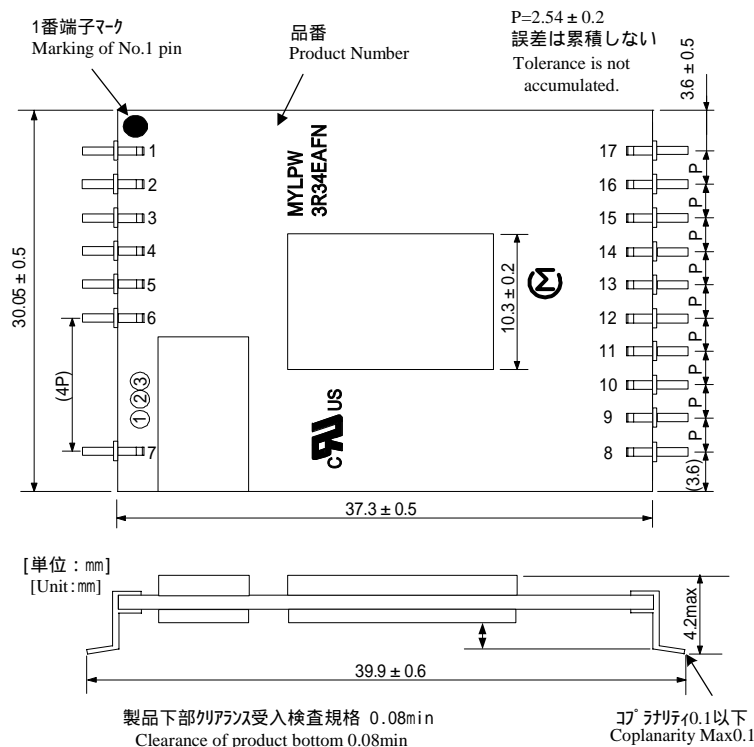

- Marking (1) MFG ID 
- (2) Product Number MYLPW3R34EAFN
- (3) Lot No.
Production factory Mark
Production Year
Production Month (1,2,3,...9,O,N,D)

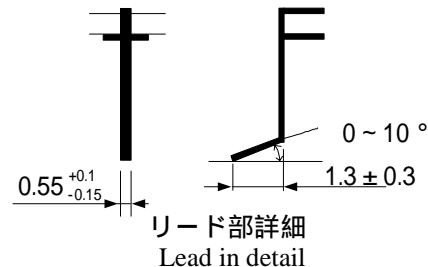

△ Note:

- This datasheet is downloaded from the website of Murata Manufacturing co., ltd. Therefore, it's specifications are subject to change or our products in it may be discontinued without advance notice. Please check with our sales representatives or product engineers before ordering.
- This datasheet has only typical specifications because there is no space for detailed specifications. Therefore, please approve our product specifications or transact the approval sheet for product specifications before ordering.

5. Pin Number and Function

Pin No.	Symbol	Function
1,7,8,17	NCo	Each pin of four corners of PWB. For dipping resin to glue on backside of motherboard.
2	+Vout	(+)Output
3	+Vout	(+)Output
4	+Vout	(+)Output
5	-Vout	(-)Output
6	-Vout	(-)Output
9	ALM	Alarm output to stop all in abnormality.
10	RC	Remote ON/OFF
11	PO	Parallel operation.
12	NC	
13	+Vin	(+)Input
14	+Vin	(+)Input
15	-Vin	(-)Input
16	-Vin	(-)Input

6. Block Diagram

6.1. Entire Product

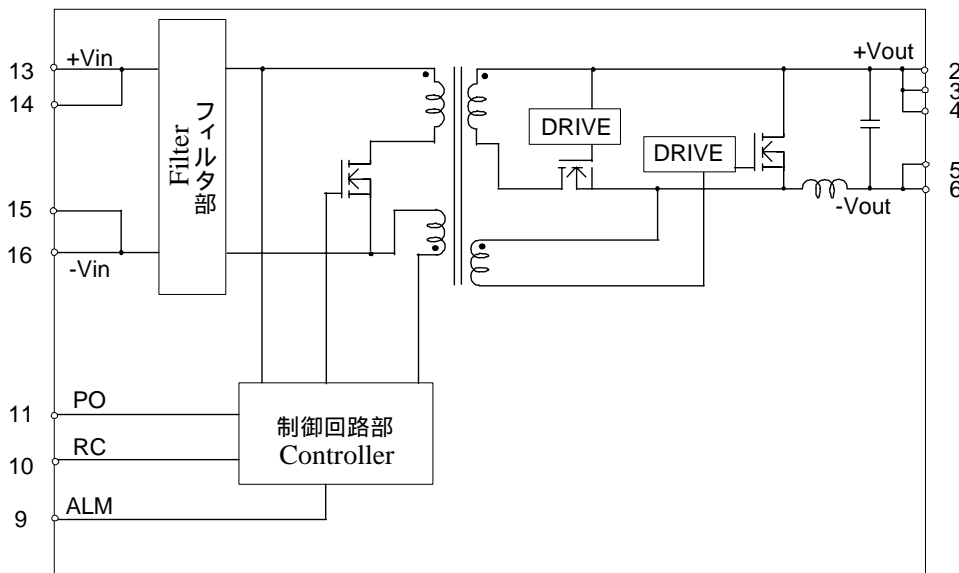

△ Note:

1. This datasheet is downloaded from the website of Murata Manufacturing co., ltd. Therefore, it's specifications are subject to change or our products in it may be discontinued without advance notice. Please check with our sales representatives or product engineers before ordering.
2. This datasheet has only typical specifications because there is no space for detailed specifications. Therefore, please approve our product specifications or transact the approval sheet for product specifications before ordering.

6.2. Input Filter

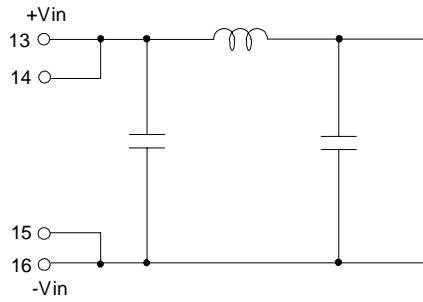

6.3. Output Filter

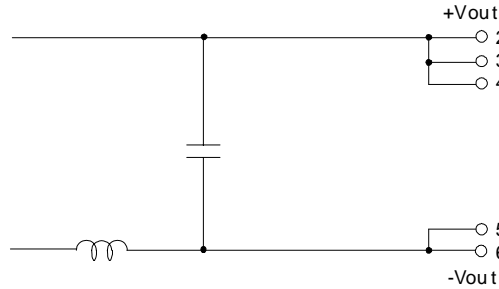

6.4. Remote ON/OFF control

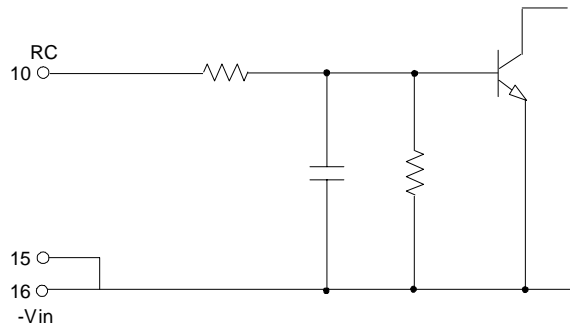

7. Environmental Conditions

7.1. Operating Temperature Range	-40 - +85 (Natural Air Convection : 0.2m/s with Vin=18 to 62V)
7.2. Operating Humidity Range	20% - 85% (No water condenses.)
7.3. Storage Temperature Range	-45 - +85
7.4. Storage Humidity Range	10% - 90% (No water condenses.)

8. Absolute Rating

Item	Unit	Absolute Rating	Remarks
Minimum Input Voltage	V	0	
Maximum Input Voltage	V	62	Slew rate 52V/10 μs
ALM Applied Voltage			
RC Applied Voltage	100ms	100	
PO Applied Voltage	V	8	
Maximum ALM Sink Current	mA	10	

No voltage, no matter how instantaneous, shall be applied beyond the absolute maximum voltage rating to this product. If you apply any voltage over this limit the product characteristics will deteriorate or the product itself will be destroyed. Even though it may continue operating for a while after the over-voltage event, its life will likely be shortened significantly. Reliability and life of the module may degrade similarly if the maximum operating voltage rating is continuously exceeded. This product is designed to operate within the maximum operating voltage rating specification.

⚠ Note:

- This datasheet is downloaded from the website of Murata Manufacturing co., ltd. Therefore, it's specifications are subject to change or our products in it may be discontinued without advance notice. Please check with our sales representatives or product engineers before ordering.
- This datasheet has only typical specifications because there is no space for detailed specifications. Therefore, please approve our product specifications or transact the approval sheet for product specifications before ordering.

9. Characteristics

9.1. Electrical Characteristics (Ta=25)

9.1.1. General Characteristics

Unless otherwise specified, (Ta= -40 to +85 with Natural Air Convection 0.2m/s)

Item	Symbol	Condition	Value			Unit
			Min.	Typ.	Max..	
Input Voltage Range	Vin	Natural Air Convection Min 0.2m/s)	18	48	62	V
Turn-on Input Voltage		Vin=increasing	16	-	18	V
Input Voltage difference of Turn-on and Turn-off		PO pin : Open or Connected to PO pin of other DC-DC Converters	1.0	-	-	V
Galvanic Isolation Voltage		Input time : 1 minute	1500	-	-	Vdc

Item	Standard	Note
Noise (Radiation, Conduction)	In accordance with VCCI Class A	
Safety Standard	Recognized UL60950(UL/C-UL), Complied IEC 60950	UL file No.E190503
	CE Marking	CE Mark is shown on a package box.

⚠ Note:

1. This datasheet is downloaded from the website of Murata Manufacturing co., ltd. Therefore, it's specifications are subject to change or our products in it may be discontinued without advance notice. Please check with our sales representatives or product engineers before ordering.
2. This datasheet has only typical specifications because there is no space for detailed specifications. Therefore, please approve our product specifications or transact the approval sheet for product specifications before ordering.

9.1.2. Output Characteristics (Ta= -40 to +85 with Natural Air Convection 0.2m/s)

Part Number		MYLPW3R34EAFN				
Item	Symbol	Condition	特性			Unit
			Min.	Typ.	Max.	
Nominal Output Voltage	Vo		-	3.3	-	V
Output Voltage Variation	regtot	Vin=18 to 62V, Io=0 to 4.5A Ta=-40 to +85	-3		+5	%
Output Current	Io	Natural Air Convection 0.2m/s (Vin=18 ~ 62V)	0	-	4.5	A
Efficiency		at rated Vin, Io, Ta=25		87.0	-	%
Ripple Voltage	Vr	Refer to Test Circuit	-	-	40	mVpp
Ripple Voltage & Noise			-	-	50	
Over Current Protection	Iocp		4.63	-		A
Over Voltage Protection	Vovp	Output halts in latch-up mode after mask time 0.5msec (typ) to avoid malfunction by noise and transient change. Input turn off and on to reset.	3.96	-		V
Low Voltage Protection	Vlvp	Output halts in latch-up mode after mask time 500msec (typ) to avoid malfunction by noise and transient change. Input turn off and on to reset.	-	-	2.97	V

 Caution

The above electrical characteristics are guaranteed in the condition that the impedance of the input power supply is sufficiently low as shown in clause 10.

Connecting an input inductance or using an input power supply with output inductance may cause an unstable operation of this product. Please check the proper operation of this product with the peripheral circuits on your product.

 Note:

1. This datasheet is downloaded from the website of Murata Manufacturing co., ltd. Therefore, it's specifications are subject to change or our products in it may be discontinued without advance notice. Please check with our sales representatives or product engineers before ordering.
2. This datasheet has only typical specifications because there is no space for detailed specifications. Therefore, please approve our product specifications or transact the approval sheet for product specifications before ordering.

9.2. Operation information

9.2.1. Reset Condition

In order to reset all function, the input Voltage is set under 5V for Min.1 second.

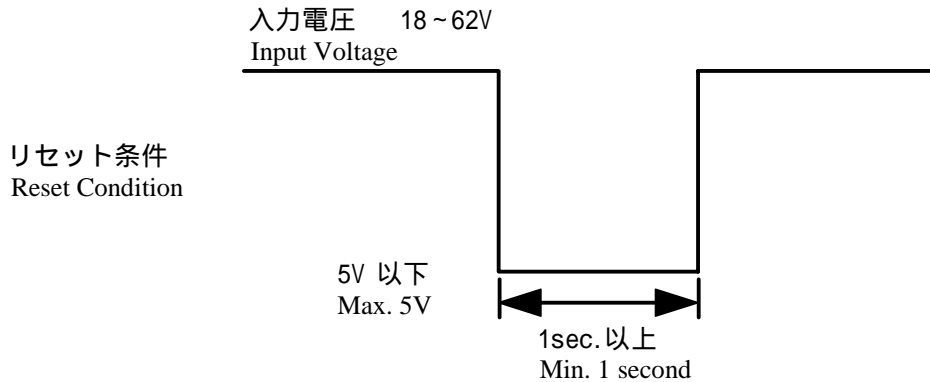

9.2.2. Over Voltage Protection

Output halts in latch-up mode after 0.5msec(typ) mask time while Output Voltage is over the value of over voltage protection specified in 9.1. clause with failure of controller circuit.

Output will re-start after input turns off for Min. 1 second with input voltage less than 5V.

Output voltage might exceed the point at over voltage protection under the specific condition of transient change of input voltage or output load, in this condition over voltage protection wait its start until the mask time.

It is recommended to evaluate your appliance installed with DC-DC converter.

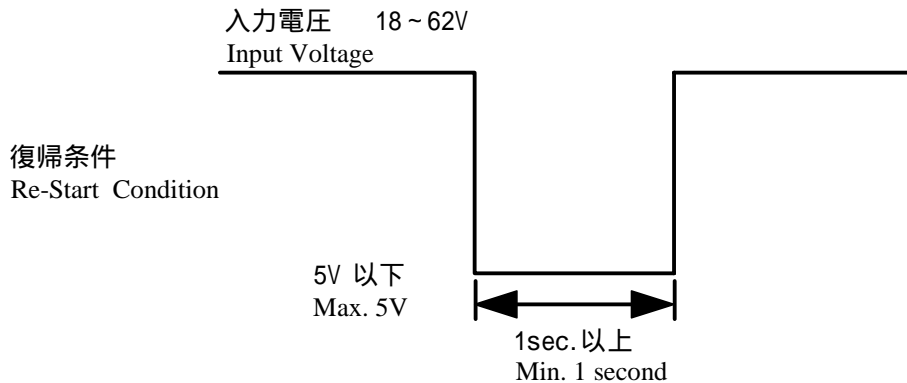

9.2.3. Low Voltage Protection

Output halts in latch-up mode after 500msec(typ) mask time while output voltage is below the value of low voltage protection specified in 9.1. clause with failure of controller circuit or over load condition.

Output will re-start after input turns off for Min.1 second with input voltage less than 5V.

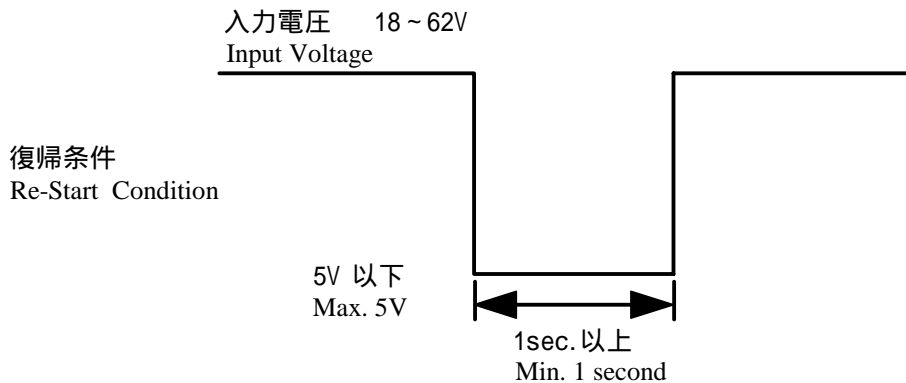

△ Note:

1. This datasheet is downloaded from the website of Murata Manufacturing co., ltd. Therefore, it's specifications are subject to change or our products in it may be discontinued without advance notice. Please check with our sales representatives or product engineers before ordering.
2. This datasheet has only typical specifications because there is no space for detailed specifications. Therefore, please approve our product specifications or transact the approval sheet for product specifications before ordering.

9.2.4. Remote On/Off Control

Start and halt is possible with a control signal.

While the control signal stops output from DC-DC converter, alarm output does not send any signal.

Start : RC is open or connected to-Vin.

Halt : RC is connected to +Vin.

9.2.5. Alarm Output

ALM pin is down to the same voltage level of-Vin pin and sends an alarm signal. (open-drain output)

Sink current in ALM pin is Max.10mA.

It is possible to halt all of the connected DC-DC converters when any one is halted with over voltage protection or low voltage protection, with connecting all ALM pins for the application of parallel/multiple operation with plural DC-DC converters.

The maximum number connecting DC-DC converters is 10pcs for the purpose of halting all DC-DC converters connected with ALM pin each other.

Please contact us when more than 10pcs.

9.2.6. Synchronous Turn-on/off

It is possible to avoid the unevenness of turn-on timing with unifying the various Turn-on input voltage to a certain voltage which one DC-DC converter has, and with connecting PO pins each other for the application of parallel/multiple operation of plural DC-DC converters.

It is necessary to connect PO pins for parallel operation.

The maximum number connecting DC-DC converters is 10pcs for the purpose of synchronous turn-on/off with connecting PO pins.

Please contact us when more than 10pcs.

9.3. Reliability

9.3.1. Reliability Test Items.

Item	Test Condition	Criteria
Humidity	According to JIS-C-0022 +40 ± 2 , 90 to 95%RH, 100 hours. Leave 4 hours at room temperature.	No damage in appearance and no deviation of electrical characteristics before and after the test.
Temperature Cycles	Repeat cycle 5 times. Leave 2 hours at room temperature. 1. -40 ± 3 /30minutes 2. Room Temp./5-10minutes 3. 85 ± 2 /30minutes 4. Room Temp./5-10minutes	
Mechanical Vibration	10 to 55Hz, max. 1.5mm amplitude, 1 hour for each of X, Y, Z directions.	
Mechanical Shock	20G, 1 time for each of X, Y, Z directions.	

9.3.2. Reliability Prediction (For reference only)

MTBF is 2.81 million hours = 321 years

at 50% nominal output current and Ta=40 ,
calculated by Telcordia SR-332.

△ Note:

1. This datasheet is downloaded from the website of Murata Manufacturing co., ltd. Therefore, it's specifications are subject to change or our products in it may be discontinued without advance notice. Please check with our sales representatives or product engineers before ordering.
2. This datasheet has only typical specifications because there is no space for detailed specifications. Therefore, please approve our product specifications or transact the approval sheet for product specifications before ordering.

10. Test Circuit

In the following test circuit, the measured values should meet those of clause 9.

10.1. General Measure Circuit

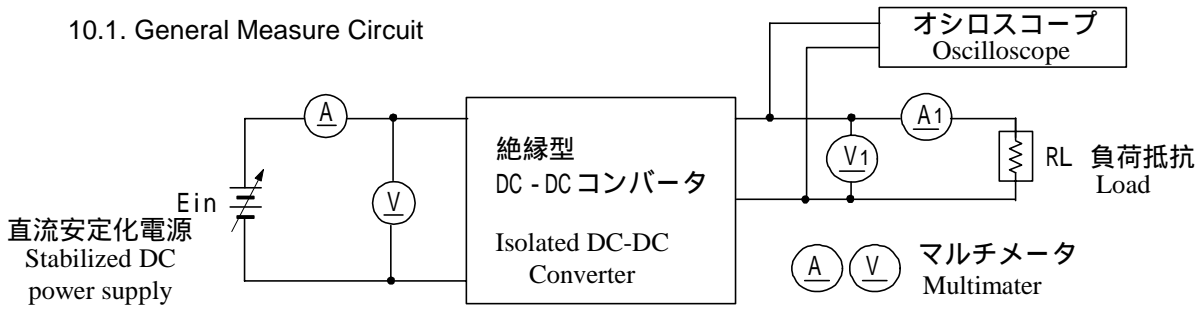

10.1.1. Output Ripple & Noise

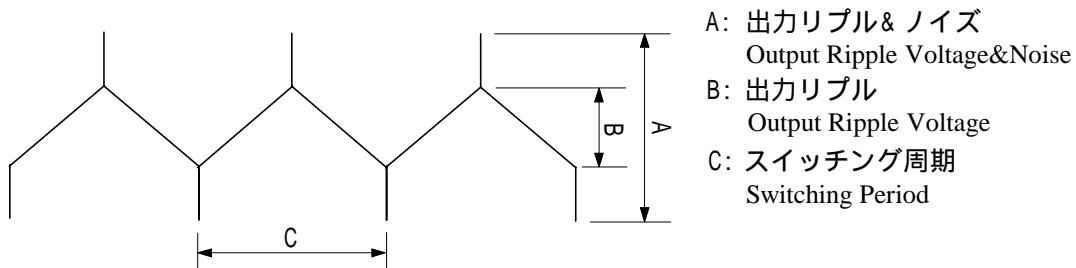
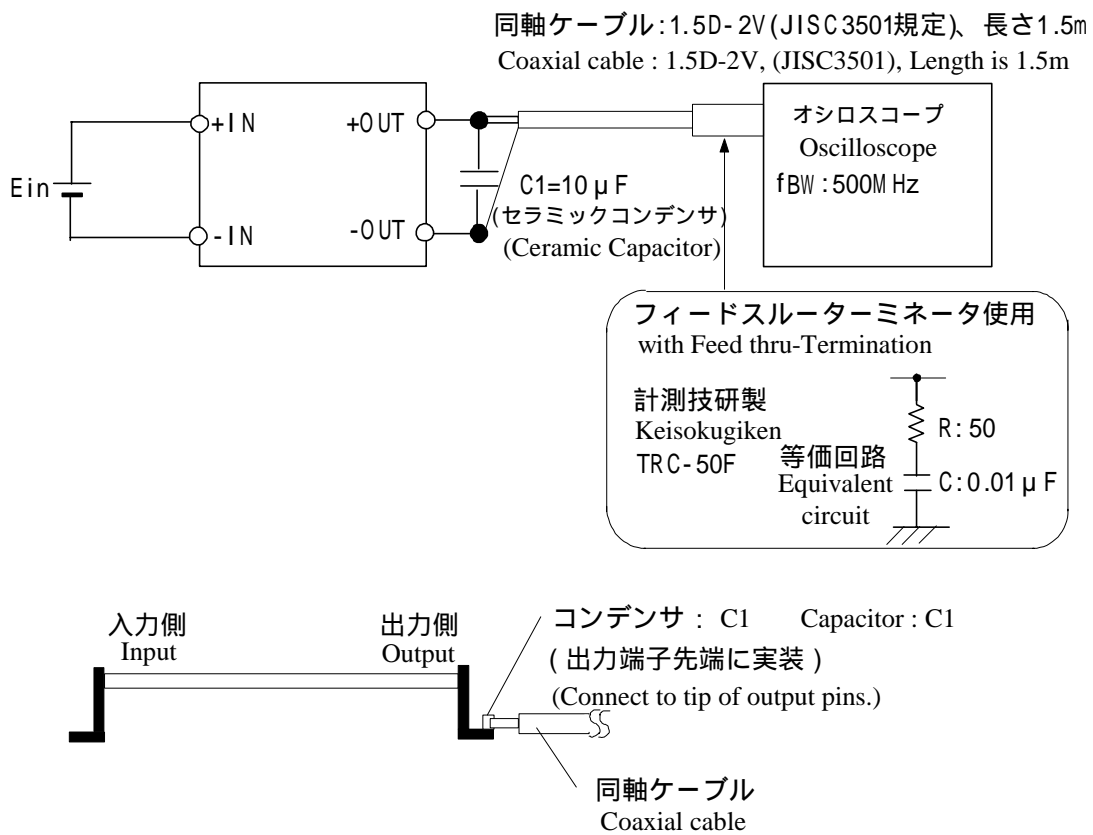

△ Note:

1. This datasheet is downloaded from the website of Murata Manufacturing co., ltd. Therefore, it's specifications are subject to change or our products in it may be discontinued without advance notice. Please check with our sales representatives or product engineers before ordering.
2. This datasheet has only typical specifications because there is no space for detailed specifications. Therefore, please approve our product specifications or transact the approval sheet for product specifications before ordering.

10.1.2. Radiation Noise

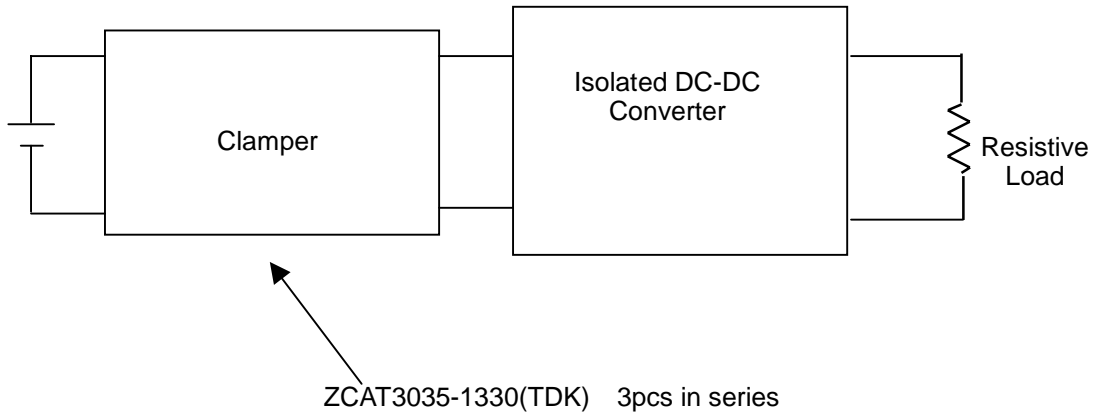

⚠ Note:

1. This datasheet is downloaded from the website of Murata Manufacturing co., ltd. Therefore, it's specifications are subject to change or our products in it may be discontinued without advance notice. Please check with our sales representatives or product engineers before ordering.
2. This datasheet has only typical specifications because there is no space for detailed specifications. Therefore, please approve our product specifications or transact the approval sheet for product specifications before ordering.

11. Packaging Information

11. 1. Tray Dimensions

DC-DC converters are put in the trays. (See Fig.1)

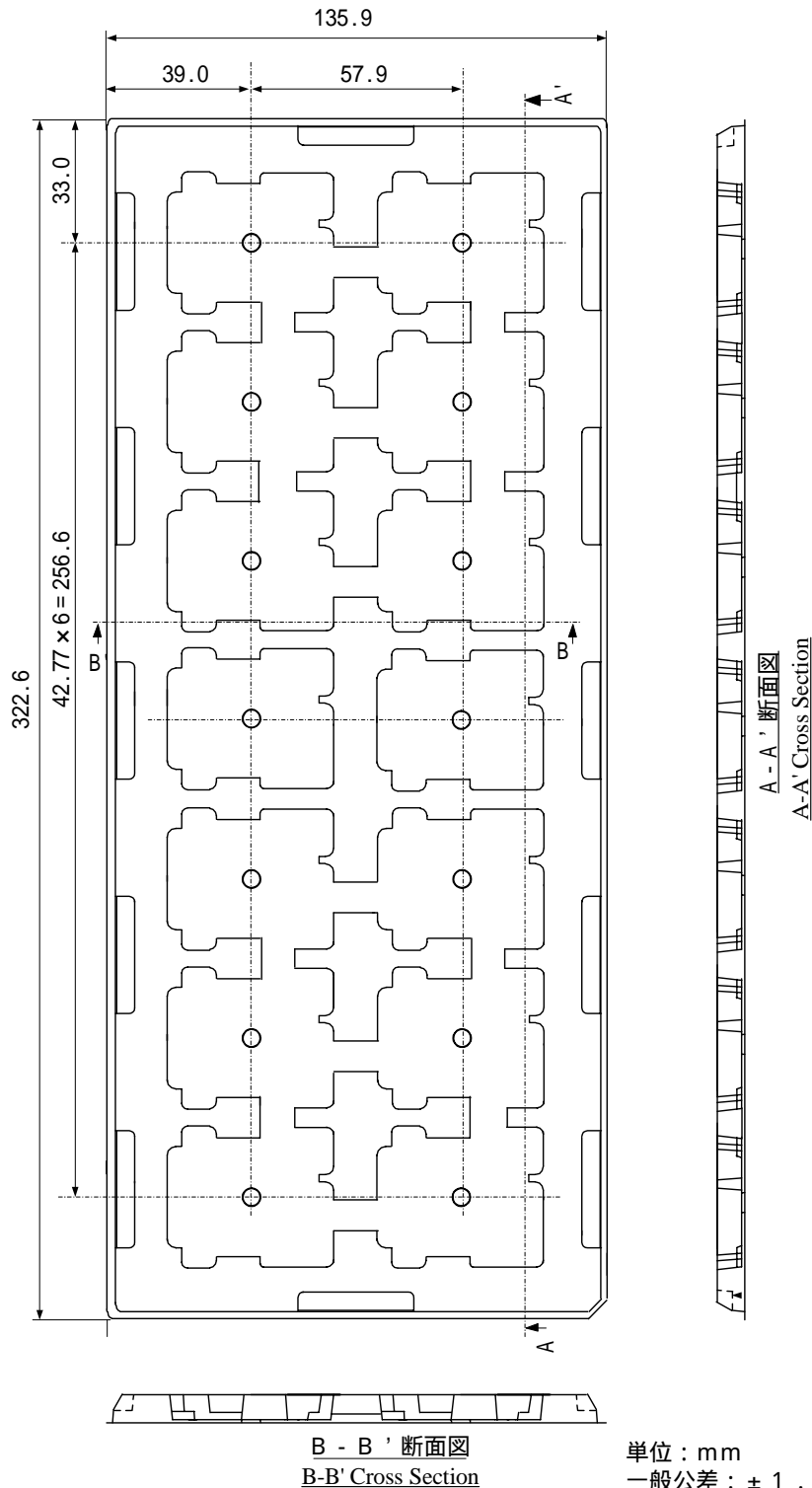

单位 : mm
一般公差 : ± 1.5
Unit : mm
General Tolerance

Fig.1

△ Note:

1. This datasheet is downloaded from the website of Murata Manufacturing co., ltd. Therefore, it's specifications are subject to change or our products in it may be discontinued without advance notice. Please check with our sales representatives or product engineers before ordering.
2. This datasheet has only typical specifications because there is no space for detailed specifications. Therefore, please approve our product specifications or transact the approval sheet for product specifications before ordering.

11. 2. Contained pieces of products per corrugated box.

Maximum Contained products pieces 84 pcs/corrugated box.

Further plural sheets of corrugated cardboard are placed on the top of the dummy tray according to number of contained trays in order to full up the space in a corrugated box.

11. 3. Packaging Form

Trays with products are lidded and packed in a corrugated box. (See Fig.2)



図2
Fig.2

Marking on the box

1. MURATA Parts Number 2. Quantity 3. Inspection No. 4. CE Mark 5. ROHS - Y

△ Note:

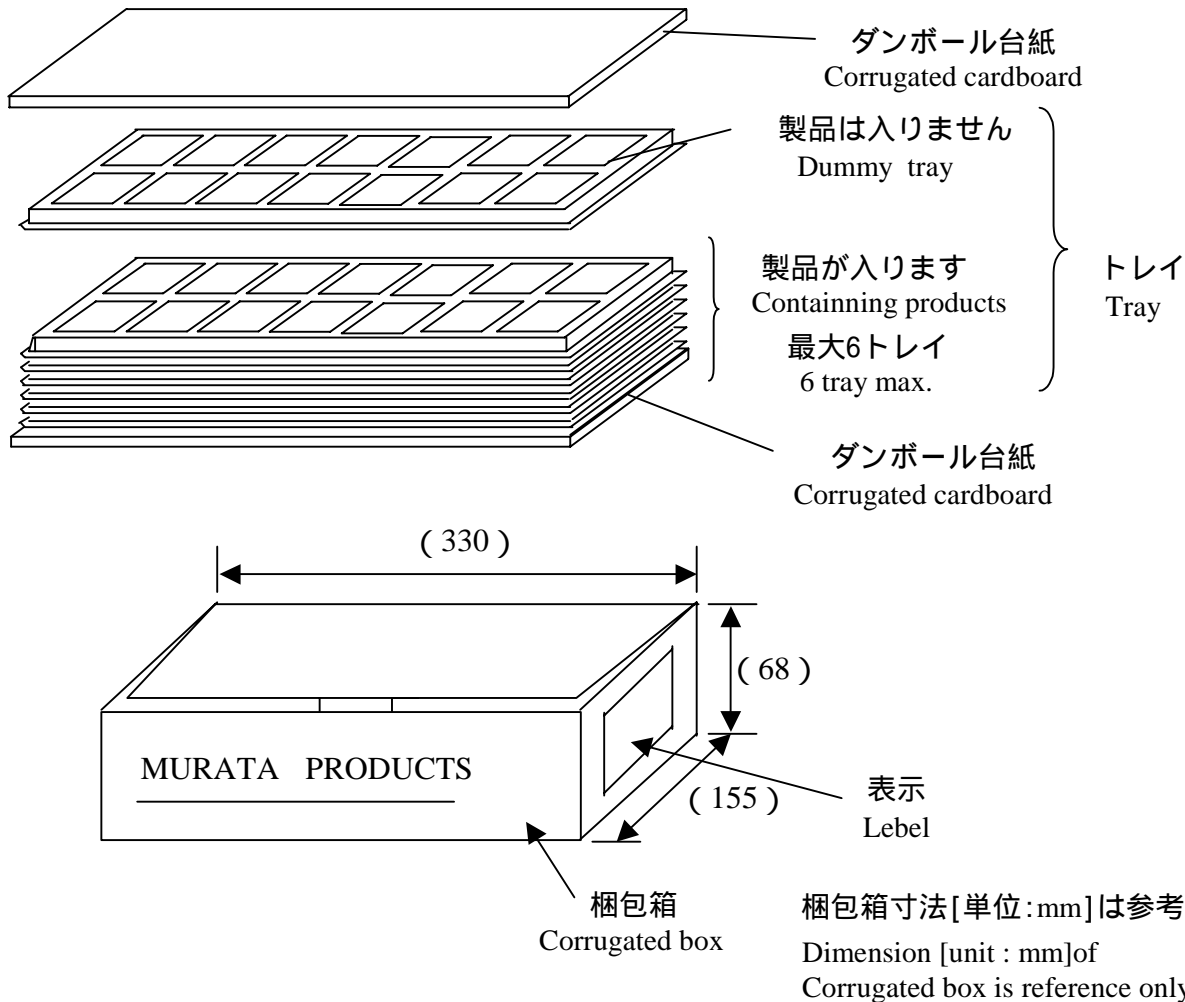
1. This datasheet is downloaded from the website of Murata Manufacturing co., ltd. Therefore, it's specifications are subject to change or our products in it may be discontinued without advance notice. Please check with our sales representatives or product engineers before ordering.
2. This datasheet has only typical specifications because there is no space for detailed specifications. Therefore, please approve our product specifications or transact the approval sheet for product specifications before ordering.

12. Production factory

Wakura Murata Mfg. Co., Ltd.
Kanazu Murata Mfg. Co., Ltd.
Komatsu Murata Mfg. Co., Ltd.

Caution

1. Be sure to provide an appropriate fail-safe function on your product to prevent secondary damage that may be caused by the functional trouble or the failure of this product.
2. Please contact us before using this product for the applications listed below which require especially high reliability for the prevention of defects and failure, which might directly cause damage to the third party's life, body or property.

Aircraft equipment
Aerospace equipment
Undersea equipment
Power plant control equipment
Medical equipment
Transportation equipment (vehicles, trains, ships, etc.)
Traffic signal equipment
Disaster prevention /crime prevention equipment
Any other application of similar complexity and/or reliability requirements to the applications listed above.

Note

1. Please make sure that the evaluation and testing are completed with this product actually assembled on your product.
2. All the items and parameters in this product specification have been prescribed on the premise that our product is used for the purpose, under the condition and in the environment mutually agreed upon. Please do not to use this product deviating from such agreement.
3. We consider it not appropriate to include other terms and conditions for transaction warranty in product specifications, drawings or other technical documents. Therefore, if your technical documents include such terms and conditions as warranty clause, product liability clause, or intellectual property infringement liability clause, we will not be able to accept such terms and conditions unless they are based on the governmental regulation or they are stated in a separate contract agreement.

Note:

1. This datasheet is downloaded from the website of Murata Manufacturing co., ltd. Therefore, it's specifications are subject to change or our products in it may be discontinued without advance notice. Please check with our sales representatives or product engineers before ordering.
2. This datasheet has only typical specifications because there is no space for detailed specifications. Therefore, please approve our product specifications or transact the approval sheet for product specifications before ordering.

13. Notice

13.1. Soldering

13.1.1. Flux

Please solder the products with no-cleaning type Rosin Flux which leaves little residue and low activity. Do not use cleaning type flux, in case that you wash the products after using cleaning type flux, they may damage mounting parts on the products and may cause defective or low quality products.

13.1.2. Solder

Please use the solder or the solder paste Sn96.5/Ag3/Cu0.5 or an equivalent type.

13.1.3. Recommended Soldering Conditions

This product is RoHS compatible. The following profile is recommended for the reflow of the SMD product using Pb-free solder paste (Sn-Ag-Cu).

Method : Full convection reflow soldering

Reflow Soldering Profile

JEDEC IPC/JEDEC J-STD-020D

Table 5-2 Classification Reflow Profile Pb-Free Assembly Large Body

Soldering temperature	: 245degC+0/-5degC
Soldering time	: 30seconds, 240 to 245degC
Heating time	: 60 to 150 seconds, over217degC
Preheating time	: 60 to 120 seconds, 150 to 200degC
Descending rate	: 6degC/ sec. Max.
Total soldering time	: 8 minutes Max., 25 to 245degC
Times	: 1time

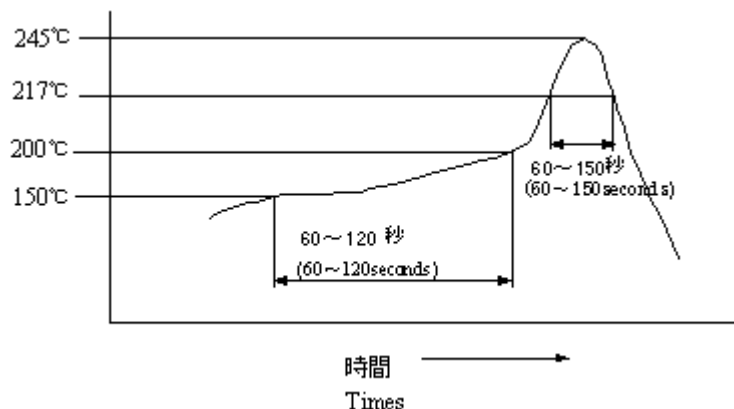

Do not vibrate for the products on reflow.

Please take care of temperature control because mounted parts may come off if the products are left under the high temperature.

Do not reflow DC-DC Converter as follows, because DC-DC Converter may fall down from a substrate during reflowing. The solder used to this product is melted in reflow process.

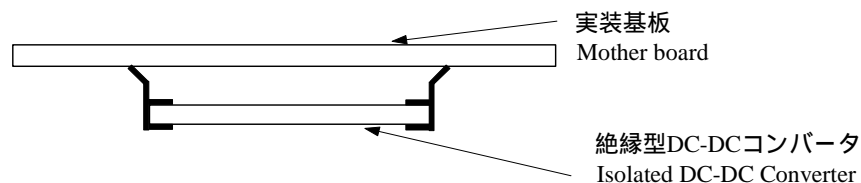

△ Note:

- This datasheet is downloaded from the website of Murata Manufacturing co., ltd. Therefore, it's specifications are subject to change or our products in it may be discontinued without advance notice. Please check with our sales representatives or product engineers before ordering.
- This datasheet has only typical specifications because there is no space for detailed specifications. Therefore, please approve our product specifications or transact the approval sheet for product specifications before ordering.

13.2. Cleaning

Please don't clean the products.

13.3. Storage

13.3.1. Please store the products in room where the temperature/humidity is stable and direct sunlight cannot come in, and use the products within 6 months after delivery.

Please avoid damp and heat or such places where the temperature greatly changes, as water may condense on this product, and the quality of characteristics may be reduced, and/or the solderability may be degraded.

If this product needs to be stored for a long time (more than 1 year), this product may be degraded in solderability and/or corroded. Please test the solderability of this product regularly.

13.3.2. Please do not store this product in the conditions such as a dusty place, a place exposed directly to sea breeze, or in an atmosphere containing corrosive gas (Cl₂, NH₃, SO₂, NO_X and so on).

13.4. Operational Environment and Operational Conditions

13.4.1. Operational Environment

This product is not water-, chemical- or corrosion-proof.

In order to prevent leakage of electricity and abnormal temperature rise of this product, do not use this product in the following conditions:

- (1) in an atmosphere containing corrosive gas (Cl₂, NH₃, SO₂, NO_X and so on)
- (2) in a dusty place
- (3) in a place exposed to direct sunlight
- (4) in such a place where water splashes or in such a humid place where water condenses
- (5) in a place exposed to sea breeze
- (6) in any other places similar to the above

13.4.2. Operational Conditions

Please use this product within specified values (power supply, temperature, input, output, load condition, and so on).

If not used within the specified values, defectiveness and deterioration of this product may be caused. Even if this product can endure the condition for short time, it may cause degradation of reliability.

It is recommended that a fuse is inserted in input line (Vin) to secure safety in any abnormality such as internal circuit of Isolated DC-DC Converter broken down.

Also please take care that the external voltage over output voltage of DC-DC Converter does not applies to output of this Isolated DC-DC Converter.

13.4.3. Note prior to use

Defectiveness and reliability degradation may be caused if high static electricity, over rated voltage or reverse voltage are applied to this product. Please be sure to avoid the followings:

- (1) over rating power supply, reverse power supply or inadequate connection of 0 V(DC)line
- (2) electrostatic discharge from production line and/or operator
- (3) electrified product from electrostatic induction

Please avoid an excessive mechanical shock.

If this product is dropped on the floor, etc., a crack to the core of inductors and monolithic ceramic capacitors may occur.

Please handle with care to avoid a strong shock to this product.

Do not give excessive mechanical stress to the product with your handling.

Please control to bend in a maximum of 0.2mm in your application.

13.5. Transportation

When transporting this product, please pack it in order to avoid damage by mechanical vibration or mechanical shock, and please give instructions and set guidelines to the carriers to prevent rough handling.

When transporting this product overseas (in particular, by sea), bad environment of transportation may be expected, therefore please pack this product considering mechanical strength, vibration-resistance and humidity-resistance.

The packaging designed for domestic sales may not suitable for overseas transportation.

Please contact us if this product with domestic packing is transported overseas.

△ Note:

1. This datasheet is downloaded from the website of Murata Manufacturing co., ltd. Therefore, it's specifications are subject to change or our products in it may be discontinued without advance notice. Please check with our sales representatives or product engineers before ordering.
2. This datasheet has only typical specifications because there is no space for detailed specifications. Therefore, please approve our product specifications or transact the approval sheet for product specifications before ordering.



Компания «ЭлектроПласт» предлагает заключение долгосрочных отношений при поставках импортных электронных компонентов на взаимовыгодных условиях!

Наши преимущества:

- Оперативные поставки широкого спектра электронных компонентов отечественного и импортного производства напрямую от производителей и с крупнейших мировых складов;
- Поставка более 17-ти миллионов наименований электронных компонентов;
- Поставка сложных, дефицитных, либо снятых с производства позиций;
- Оперативные сроки поставки под заказ (от 5 рабочих дней);
- Экспресс доставка в любую точку России;
- Техническая поддержка проекта, помощь в подборе аналогов, поставка прототипов;
- Система менеджмента качества сертифицирована по Международному стандарту ISO 9001;
- Лицензия ФСБ на осуществление работ с использованием сведений, составляющих государственную тайну;
- Поставка специализированных компонентов (Xilinx, Altera, Analog Devices, Intersil, Interpoint, Microsemi, Aeroflex, Peregrine, Syfer, Eurofarad, Texas Instrument, Miteq, Cobham, E2V, MA-COM, Hittite, Mini-Circuits, General Dynamics и др.);

Помимо этого, одним из направлений компании «ЭлектроПласт» является направление «Источники питания». Мы предлагаем Вам помощь Конструкторского отдела:

- Подбор оптимального решения, техническое обоснование при выборе компонента;
- Подбор аналогов;
- Консультации по применению компонента;
- Поставка образцов и прототипов;
- Техническая поддержка проекта;
- Защита от снятия компонента с производства.



Как с нами связаться

Телефон: 8 (812) 309 58 32 (многоканальный)

Факс: 8 (812) 320-02-42

Электронная почта: org@eplast1.ru

Адрес: 198099, г. Санкт-Петербург, ул. Калинина, дом 2, корпус 4, литера А.