

LTC3212
 RGB LED Driver and
 Charge Pump

DESCRIPTION

WARNING!
Do not look directly at operating LED.

This circuit produces light that can damage eyes.

Demonstration circuit 1187 is an RGB LED Driver and Charge Pump featuring the LTC3212.

The LTC3212 is a low noise charge pump capable of driving three LEDs up to 25mA each. This device requires only one flying capacitor, two by-pass capacitors, and one to three programming resistors. Each LED may be turned on individually, in combination with each other, or in white mode us-

ing a single wire interface. White mode optimizes the red, green, and blue current settings to provide the best white color.

LED currents are regulated using internal low dropout current sources. Automatic mode switching optimizes efficiency by switching modes only when a dropout is detected. Refer to the LTC3212 datasheet for more information on this device.

Design files for this circuit board are available. Call the LTC factory.

L, LTC, LTM, and LT are registered trademarks of Linear Technology Corporation. Other product names may be trademarks of the companies that manufacture the products.

 PERFORMANCE SUMMARY Specifications are at $T_A = 25^\circ\text{C}$

PARAMETER	CONDITIONS	MIN	TYP	MAX	UNITS
Input Supply Range		2.7		5.5	V
I_{VIN} Shutdown Current	LEDEN = LOW		3	8	μA
I_{VIN} Operating Current	$I_{CPO} = 0\text{mA}$, 1X Mode		0.4		mA
	$I_{CPO} = 0\text{mA}$, 2X Mode		2.0		mA
I_{LED}	$R_{ISET} = 33.87\text{K}\Omega$ (Not in White Mode)		5.24		mA
	$R_{ISET} = 58.87\text{K}\Omega$ (Not in White Mode)		3.0		mA
	$R_{ISET} = 8.87\text{K}\Omega$ (Not in White Mode)		20.0		mA
I_{LEDG} (WHITE MODE)	$R_{ISETG} = 33.87\text{K}\Omega$		5.24		mA
	$R_{ISETG} = 58.87\text{K}\Omega$		3.0		mA
	$R_{ISETG} = 8.87\text{K}\Omega$		20.0		mA
I_{LEDB} (WHITE MODE)	$R_{ISETG} = 33.87\text{K}\Omega$		3.93		mA
	$R_{ISETG} = 58.87\text{K}\Omega$		2.62		mA
	$R_{ISETG} = 8.87\text{K}\Omega$		15.0		mA
I_{LEDR} (WHITE MODE)	$R_{ISETG} = 33.87\text{K}\Omega$		4.72		mA
	$R_{ISETG} = 58.87\text{K}\Omega$		2.71		mA
	$R_{ISETG} = 8.87\text{K}\Omega$		18.0		mA
I_{LED} Dropout Voltage (V_{ILED})	Mode Switching Threshold, $I_{LED} = 15\text{mA}$		150		mV
Charge Pump Output Clamp Voltage			5.1		V
I_{CPO}		0		75	mA

LTC3212

OPERATING PRINCIPLES

The DC1187 has a programmable IC on board that communicates to the DC590 USB to I²C board and drives the LTC3212 via a single wire interface. The current in each LED output is set by adjusting the resistance at the associated ISET pin. Each ISET pin is connected to an 8.87K Ω resistor in series with a 50K Ω potentiometer. This allows the user to adjust each ISET resistance between 8.87K Ω and 58.87K Ω to experiment with different

color variations and intensities. The current for LEDG is set by the RSETG potentiometer, R4. The currents for LEDR and/or LEDB are also set by the RSETG potentiometer when in white mode and when ISETR and/or ISETB are tied to VIN via JP2 and JP3 respectively. Otherwise, the LEDR and LEDB output currents are set by the RSETR potentiometer, R6, and RSETB potentiometer, R5, respectively.

QUICK START PROCEDURE

Demonstration circuit 1187 is easy to set up to evaluate the performance of the LTC3212. Refer to Figure 1 for proper measurement equipment setup and follow the procedure below:

NOTE. When measuring the input or output voltage ripple, care must be taken to avoid a long ground lead on the oscilloscope probe. Measure the input or output voltage ripple by touching the probe tip directly across the VIN or CPO and GND terminals. See Figure 2 for proper scope probe technique.

1. Place jumpers in the following positions:

JP1 LEDEN: Up, DC590 position.

JP2 ISETR: Down, RSETR position.

JP3 ISETB: Down, RSETB position.

2. Make sure that the RSETG, RSETR, and RSETB potentiometers are set approximately to the center position (adjustment slot is perpendicular to top of board).

3. Refer to the DC590 Quick Start Guide for QuikEval™ setup and software installation details.

4. If using the DC590B board, make sure the VCCIO jumper, JP6, on the DC590B board is set to the 5V position. The microcontroller on the DC1187 board needs 5V to operate properly.

5. Make sure the USB cable is connected between the computer and the DC590 controller board.

6. Connect DC1187 to the DC590 USB Serial Controller using the supplied 14-conductor ribbon cable as shown in Figure 1.

7. With power off, connect the input power supply to VIN and GND with a series ammeter and a voltmeter as shown in Figure 1.

8. Turn on the input power supply and set the VIN voltage to 3.6V.

NOTE. Make sure that the input voltage does not exceed 6V.

9. Run the QuikEval program. The program detects the DC1187 and displays the LTC3212 control window (shown in Figure 3).

10. Select the Green/Red option button on the LTC3212 control window and observe that the RGB LED illuminates light greenish.

11. Adjust RSETG fully counterclockwise and observe that the RGB LED changes to a yellowish green color.

12. Adjust RSETR fully clockwise and observe that the RGB LED color changes to light orange.

13. Move the ISETR jumper from the RSETR position to the RSETG position and observe that the RGB LED color changes to light green.

14. Select the Blue/Green option button on the LTC3212 control window and observe that the RGB LED illuminates light blue.

- 15.** Slowly adjust RSETB fully counterclockwise then adjust RSETG fully clockwise. Observe that the RGB LED changes from light blue to greenish blue.
- 16.** Move the ISETB jumper from RSETB to RSETG and observe the RGB LED color change.
- 17.** Select the Blue/Red option button on the LTC3212 control window and observe that the RGB LED illuminates bluish red.
- 18.** Move the ISETR jumper to the RSETR position and the ISETB jumper to the RSETB position. Observe that the LED illuminates pink.
- 19.** Select the White Mode option button on the LTC3212 control window. Observe that the RGB illuminates a whitish color.
- 20.** Slowly adjust the RSETG potentiometer fully counter-clockwise and observe that the LED changes intensity but not color.
- 21.** Select the LEDs OFF option button and turn off power when done.

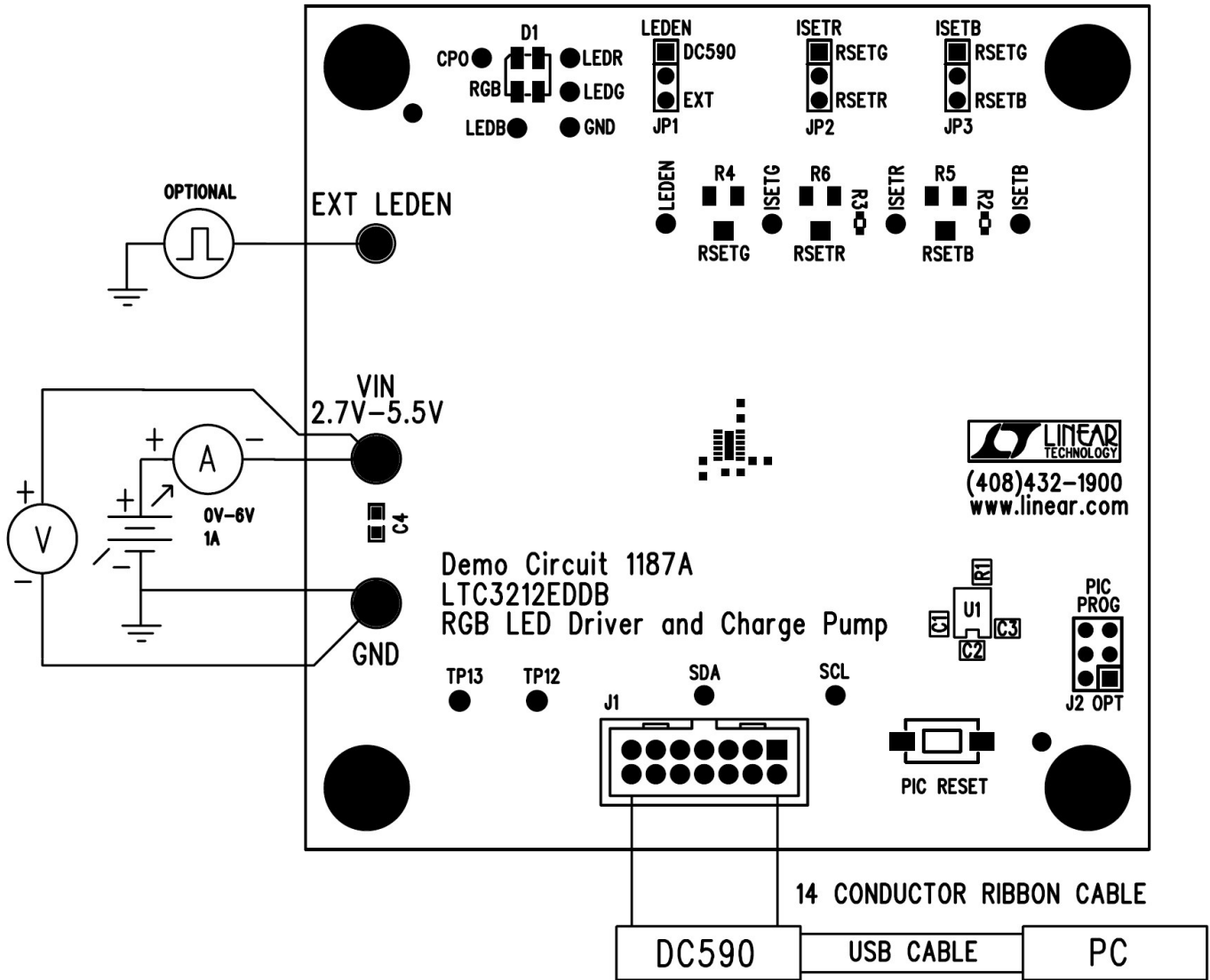

Figure 1. Proper Measurement Equipment Setup

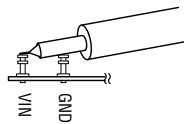

Figure 2. Measuring Input or Output Ripple

LTC3212 SOFTWARE CONTROL WINDOW

The LTC3212 software control window consists of 7 LED Enable Mode option buttons, which allow the user to select which LEDs to turn on or off, or

select white mode. White mode turns on the three LEDs at an optimal intensity to display white light. A Pulse text box displays how many pulses were

sent to the LTC3212. The Update button updates the microcontroller with the proper timing information and updates the LTC3212 to match the selected LED Enable mode option button. The Update button will need to be selected if whenever VIN applied, the 14 conductor ribbon cable is connected, if the DC590 board is connected, or if the PIC RESET button on the DC1187 board was depressed. The PIC RESET button resets the PIC microcontroller on the demo board. The “View LTC3212 Product Page” button searches the LTC

web site for the LTC3212, providing an internet connection is available.

LED ENABLE SETTINGS

PULSES	R	G	B
0	0	0	0
1	0	0	1
2	0	1	0
3	0	1	1
4	1	1	0
5	1	0	1
6	1	0	0
7+	WHITE MODE		

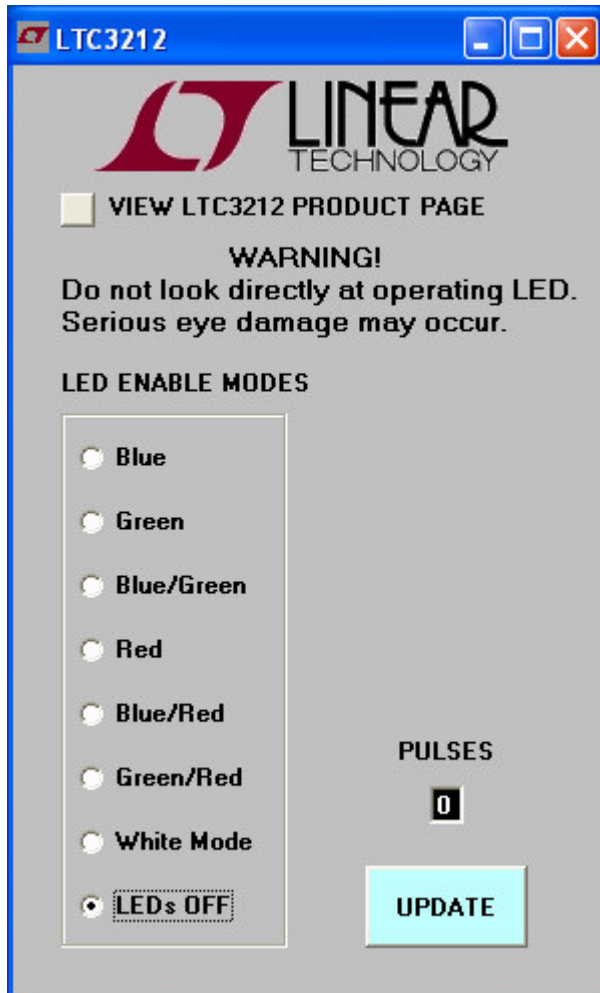
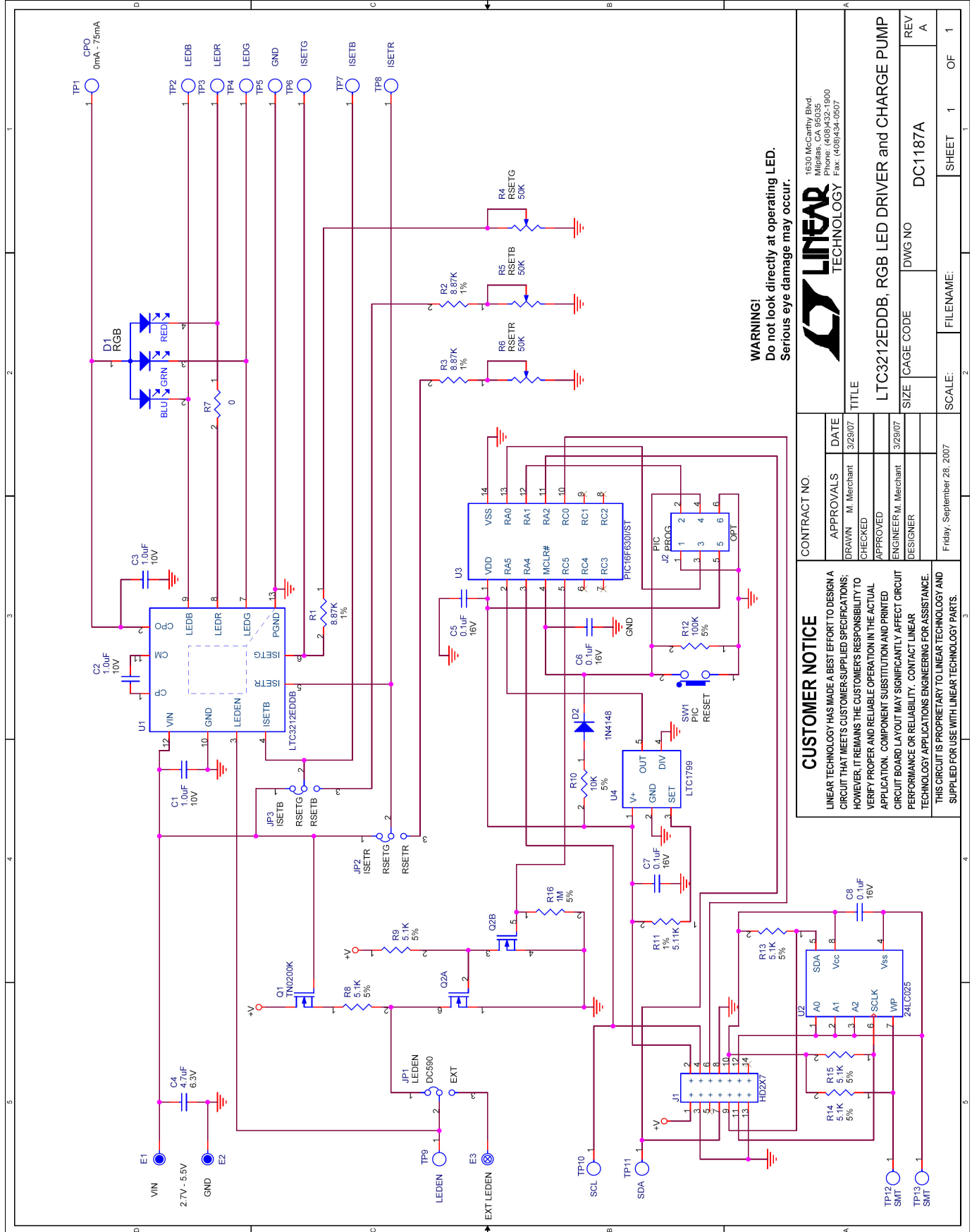

Figure 3. LTC3212 Control Window



WARNING!
Do not look directly at operating LED.
Serious eye damage may occur.

<p>CUSTOMER NOTICE</p> <p>LINEAR TECHNOLOGY HAS MADE A BEST EFFORT TO DESIGN A CIRCUIT THAT MEETS CUSTOMER-SUPPLIED SPECIFICATIONS; HOWEVER, IT REMAINS THE CUSTOMER'S RESPONSIBILITY TO VERIFY PROPER AND RELIABLE OPERATION IN THE ACTUAL APPLICATION. COMPONENT SUBSTITUTION AND PRINTED CIRCUIT BOARD LAYOUT MAY SIGNIFICANTLY AFFECT CIRCUIT PERFORMANCE OR RELIABILITY. CONTACT LINEAR TECHNOLOGY APPLICATIONS ENGINEERING FOR ASSISTANCE.</p> <p>THIS CIRCUIT IS PROPRIETARY TO LINEAR TECHNOLOGY AND SUPPLIED FOR USE WITH LINEAR TECHNOLOGY PARTS.</p>		<p>CONTRACT NO.</p>	
APPROVALS	DATE	TITLE	
DRAWN: M. Merchant	3/29/07	LTC3212EDDB, RGB LED DRIVER and CHARGE PUMP	
CHECKED		SIZE	CAGE CODE
APPROVED		DWG NO	DC1187A
ENGINEER: M. Merchant	3/29/07	REV	A
DESIGNER		SCALE:	1 OF 1
Friday, September 28, 2007		FILENAME:	SHEET



1630 McCarthy Blvd.
Milpitas, CA 95035
Tel: (408) 255-6700
Fax: (408) 255-6507

Item	Qty	Ref - Des	Desc	Manufacturer's Part Number
REQUIRED CIRCUIT COMPONENTS:				
1	3	C1,C2,C3	CAP, 1.0uF X5R 10% 10V 0402	MURATA, GRM155R61A105K
2	1	D1	LED, SMT RGB	NICHIA, NSCM315C
3	1	R1	RES, 8.87K CHIP 1% 1/8W	VISHAY, CRCW04028K87FKED
4	1	U1	IC, RGB LED DRIVER	LINEAR TECH, LTC3212EDDB
ADDITIONAL DEMO BOARD CIRCUIT COMPONENTS:				
1	4	C5,C6,C7,C8	CAP, 0.1uF X7R 10% 10V 0402	MURATA, GRM155R71A104K
2	1	C4	CAP, 4.7uF X5R 10% 6.3V 0603	TDK, C1608X5R0J475K
3	2	R2,R3	RES, 8.87K CHIP 1% 1/8W	VISHAY, CRCW04028K87FKED
4	3	R4,R5,R6	POT, 50K SMT 20% 1/8W	BOURNS, 3313J-1-503E
5	1	R7	RES., 0.0 CHIP 1% 1/8W	VISHAY, CRCW04020000Z0ED
6	6	R8,R9,R11,R13,R14,R15	RES, 5.11K CHIP 1% 1/8W	VISHAY, CRCW04025K11FKED
7	1	R10	RES, 10K CHIP 5% 1/8W	VISHAY, CRCW040210K0JNED
8	1	R12	RES, 100K CHIP 5% 1/8W	VISHAY, CRCW0402100KJNED
9	1	R16	RES, CHIP 1M OHM 5% 0402	VISHAY, CRCW04021M00JNED
10	1	D2	DIODE, 1N4148	DIODES INC., 1N4148WS
11	1	U2	IC, SERIAL EEPROM	MICROCHIP, 24LC025-I/ST
12	1	U3	IC, FLASH 8-BIT MCU	MICROCHIP, PIC16F630I/ST
13	1	U4	IC, OSCILLATOR	LINEAR TECHNOLOGY, LTC1799IS5
14	1	Q1	MOSFET, N-CHANNEL	VISHAY, TN0200K
15	1	Q2	MOSFET, DUAL N-CHANNEL	VISHAY, Si1912EDH
		Q2 (Second Source)	MOSFET, DUAL N-CHANNEL	FAIRCHILD, FDG6303N
HARDWARE FOR DEMO BOARD ONLY:				
1	1	J1	HEADER, 2X7 2MM STRAIGHT	MOLEX/WALDOM, 87831-1420
2	0	J2	HEADER, 2X3 2MM	
3	2	E1,E2	TURRET, TESTPOINT	MILL MAX, 2501-2
4	1	E3	TURRET, TESTPOINT	MILL MAX, 2308-2
5	3	JP1,JP2,JP3	HEADER, 3 POS, 2MM	SAMTEC, TMM-103-02-L-S
6	3	JP1,JP2,JP3	SHUNT, 2MM	SAMTEC, 2SN-BK-G
7	1	SW1	SWITCH, PUSH BUTTON	PANASONIC, EVQPPFA25
8	4		STANDOFFS	KEYSTONE, 8831
9	1		CABLE ASSY, 8" STRIP	LINEAR RIBBON CABLE, CA-2440



Компания «ЭлектроПласт» предлагает заключение долгосрочных отношений при поставках импортных электронных компонентов на взаимовыгодных условиях!

Наши преимущества:

- Оперативные поставки широкого спектра электронных компонентов отечественного и импортного производства напрямую от производителей и с крупнейших мировых складов;
- Поставка более 17-ти миллионов наименований электронных компонентов;
- Поставка сложных, дефицитных, либо снятых с производства позиций;
- Оперативные сроки поставки под заказ (от 5 рабочих дней);
- Экспресс доставка в любую точку России;
- Техническая поддержка проекта, помощь в подборе аналогов, поставка прототипов;
- Система менеджмента качества сертифицирована по Международному стандарту ISO 9001;
- Лицензия ФСБ на осуществление работ с использованием сведений, составляющих государственную тайну;
- Поставка специализированных компонентов (Xilinx, Altera, Analog Devices, Intersil, Interpoint, Microsemi, Aeroflex, Peregrine, Syfer, Eurofarad, Texas Instrument, Miteq, Cobham, E2V, MA-COM, Hittite, Mini-Circuits, General Dynamics и др.);

Помимо этого, одним из направлений компании «ЭлектроПласт» является направление «Источники питания». Мы предлагаем Вам помощь Конструкторского отдела:

- Подбор оптимального решения, техническое обоснование при выборе компонента;
- Подбор аналогов;
- Консультации по применению компонента;
- Поставка образцов и прототипов;
- Техническая поддержка проекта;
- Защита от снятия компонента с производства.



Как с нами связаться

Телефон: 8 (812) 309 58 32 (многоканальный)

Факс: 8 (812) 320-02-42

Электронная почта: org@eplast1.ru

Адрес: 198099, г. Санкт-Петербург, ул. Калинина, дом 2, корпус 4, литера А.