

DESCRIPTION

The MPQ8904 is a low-current, low-dropout, linear regulator that operates on a single 2.5V-to-6.5V input supply. An external resistor controls the output voltage. The MPQ8904 can supply up to 500mA of load current. The enable pin (EN) allows the part to enter a low-current shutdown mode (EN=0). The MPQ8904 features thermal overload and current limit protection. It is available in an 8-pin QFN (2×3mm) package.

FEATURES

- Power-Good Open Collector Output
- Guaranteed Industrial/Automotive Temp. Range Limits
- Operates from a 2.5V-to-6.5V Input
- Low 300mV Dropout at 500mA Output
- Stable with Very Small Ceramic Capacitors
- 2.5% Feedback Reference
- Adjustable Output Voltage from 0.5V to 5V
- Better than 0.001%/mA Load Regulation
- Stable with Low-ESR Output Capacitor
- Low 140µA Ground Current
- Internal Thermal Protection
- Current Limit Protection
- 7µA Typical Quiescent Current at Shutdown
- Available in AEC-Q100 Qualified Grade 1

APPLICATIONS

- Low-Current Regulators
- Battery-Powered Systems
- Mobile Devices, such as Cell Phones and GPS Navigators

All MPS parts are lead-free and adhere to the RoHS directive. For MPS green status, please visit MPS website under Products, Quality Assurance page. "MPS" and "The Future of Analog IC Technology" are registered trademarks of Monolithic Power Systems, Inc.

TYPICAL APPLICATION

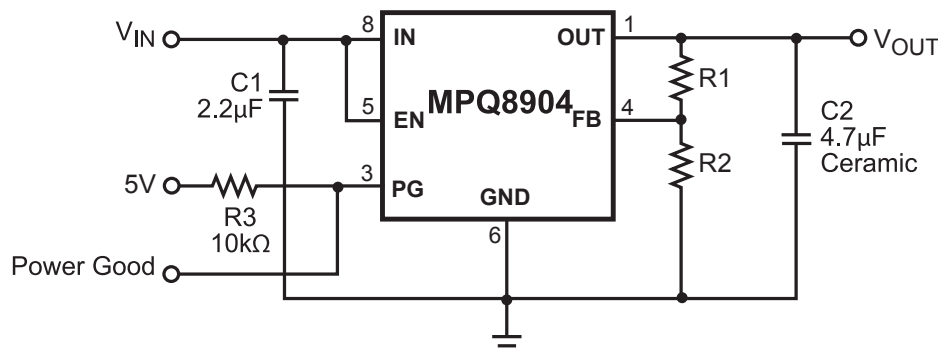

ORDERING INFORMATION

Part Number	Package	Top Marking
MPQ8904DD-AEC1*	QFN8 (2 x 3mm)	T3
MPQ8904DD**		

* For Tape & Reel, add suffix -Z (e.g. MPQ8904DD-AEC1-Z);
 For RoHS, compliant packaging, add suffix -LF (e.g. MPQ8904DD-AEC1-LF-Z).

** For Tape & Reel, add suffix -Z (e.g. MPQ8904DD-Z);
 For RoHS, compliant packaging, add suffix -LF (e.g. MPQ8904DD-LF-Z).

PACKAGE REFERENCE

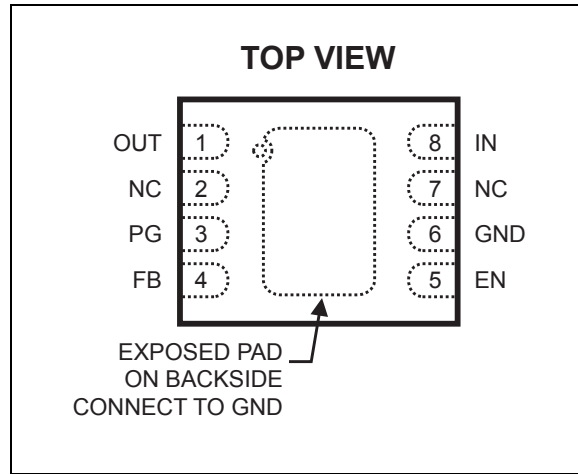

ABSOLUTE MAXIMUM RATINGS ⁽¹⁾

IN, FB to GND -0.3V to +7V
 EN to GND..... -0.3V to $V_{IN} + 0.3V$
 OUT..... -0.3V to $V_{IN} + 0.3V$
 Continuous Power Dissipation ($T_A = +25^{\circ}C$) ⁽²⁾
 2.5W

Junction Temperature 150°C
 Lead Temperature 260°C
 Storage Temperature -65°C to +150°C

Recommended Operating Conditions ⁽³⁾

Input Voltage V_{IN} 2.5V to 6.5V
 Output Voltage..... 0.5V to 5V
 Load Current..... 500mA Maximum
 Operating Junction Temp. (T_J). -40°C to +125°C

Thermal Resistance ⁽⁴⁾

	θ_{JA}	θ_{JC}
QFN8 (2 x 3mm).....	55	12 ... °C/W

Notes:

- 1) Exceeding these ratings may damage the device.
- 2) The maximum allowable power dissipation is a function of the maximum junction temperature $T_J(MAX)$, the junction-to-ambient thermal resistance θ_{JA} , and the ambient temperature T_A . The maximum allowable continuous power dissipation at any ambient temperature is calculated by $P_D(MAX) = (T_J(MAX) - T_A) / \theta_{JA}$. Exceeding the maximum allowable power dissipation will cause excessive die temperature, and the regulator will go into thermal shutdown. Internal thermal shutdown circuitry protects the device from permanent damage.
- 3) The device is not guaranteed to function outside of its operating conditions.
- 4) Measured on approximately 1" square of 1 oz copper.

ELECTRICAL CHARACTERISTICS

$V_{IN} = 3.3V$, $V_{OUT} = 1.2V$, $C_{OUT} = 4.7\mu F$, $C_{IN} = 2.2\mu F$, $T_J = -40^{\circ}C$ to $+125^{\circ}C$, Typical value are $T_J = 25^{\circ}C$, unless otherwise noted.

Parameter	Symbol	Condition	Min	Typ ⁽⁴⁾	Max	Units
Operating Voltage		$I_{OUT} = 1mA$	2.5		6.5	V
Ground Pin Current ⁽⁷⁾		$I_{OUT} = 1mA$		140	200	μA
		$I_{OUT} = 500mA$		7	12	mA
Shutdown Current		$V_{EN} = 1.45V$, $V_{IN} = 5V$		7	15	μA
FB Regulation Voltage		$T_J = +25^{\circ}C$	0.484	0.496	0.508	V
		$-40^{\circ}C \leq T_J \leq +125^{\circ}C$	0.478	0.496	0.513	
Dropout Voltage ⁽⁸⁾		$I_{OUT} = 500mA$	200	300	450	mV
Line Regulation ⁽⁶⁾		$I_{OUT} = 1mA$, $V_{IN} = (V_{OUT} + 0.5V)$ to $6.5V$ ⁽⁷⁾	-0.1	0.015	0.1	%/V
Load Regulation ⁽⁶⁾		$I_{OUT} = 1mA$ to $500mA$, $V_{IN} = V_{OUT} + 0.5V$	-0.1	0.005	0.1	%/mA
Power-Good Output Voltage, Low ⁹	V_{OL}	$I_{sink} = 0.5mA$	0	0.5	1	V
EN Input, High			1.2			V
EN Input, Low					0.4	V
EN Input Bias Current		$V_{EN} = 1.5V$		0.05	1	μA
Thermal Protection ⁽⁵⁾				155		$^{\circ}C$
Current Limit			650	850		mA

Notes:

- 5) Parameter is guaranteed by design, not production tested.
- 6) Resistors for V_{OUT} measurement are 10k Ω , 14k Ω , 1%
- 7) The ground current does not include current through feedback current
- 8) Dropout Voltage is defined as the input to output differential when the output voltage drops 1% below its nominal value
- 9) $V_{FEEDBACK}$ is 90% of the regulated value with 10k Ω pull-up to 5V

TYPICAL PERFORMANCE CHARACTERISTICS

Based on the Figure 2 Typical Application Circuit

C1=2.2μF, C2 =4.7μF, C3=1nF, T_A = +25°C, unless otherwise noted.

Voltage Dropout vs Current

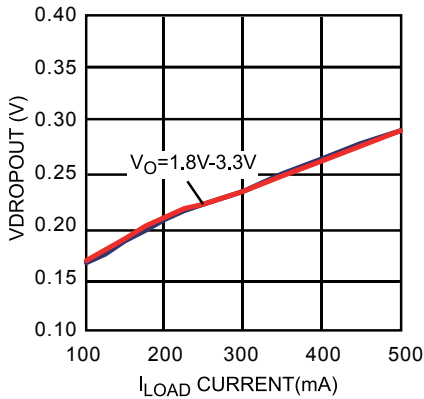

Line Regulation

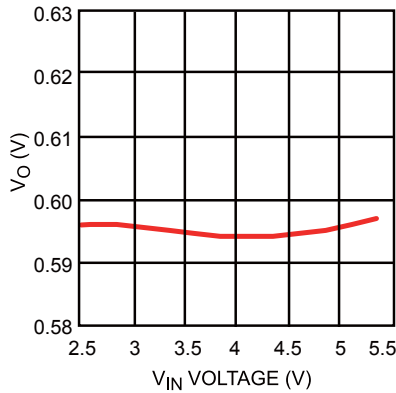

Load Regulation

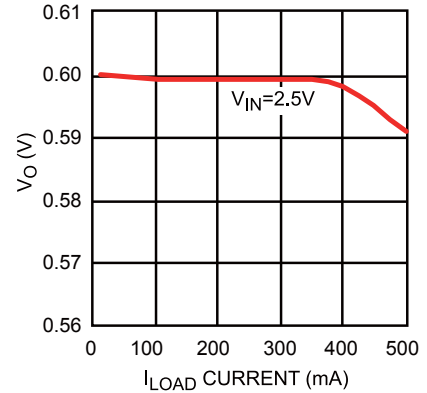

Line Regulation

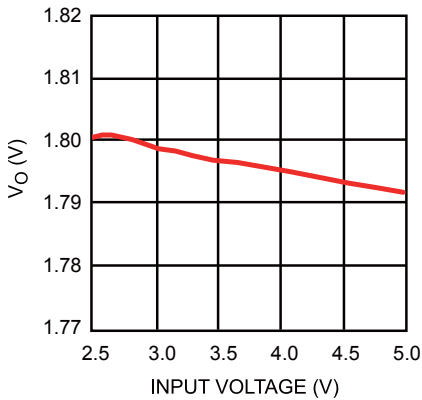

Load Regulation

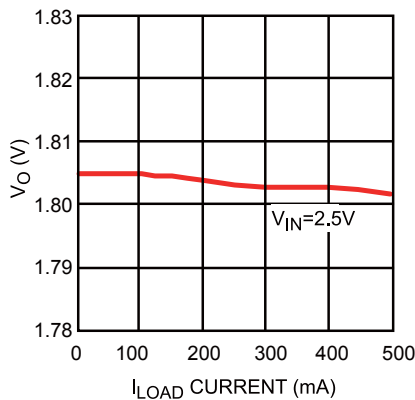

Line Regulation

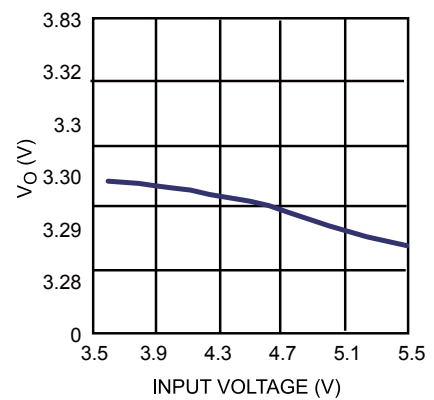

Load Regulation

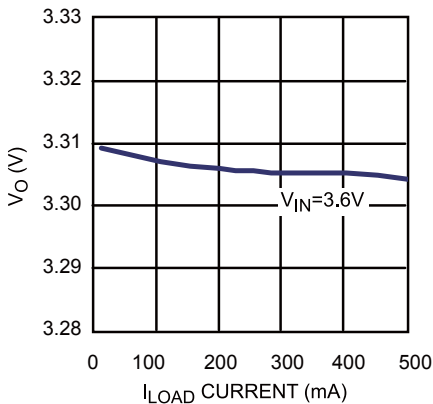

Supply Current vs. Input Voltage

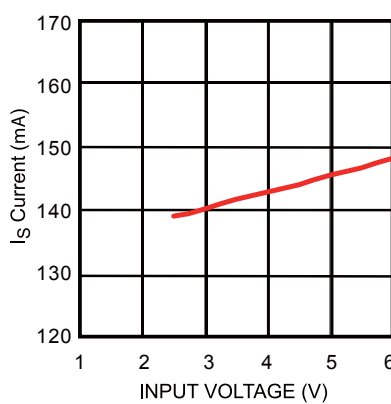

Shut Down Current vs. Input Voltage

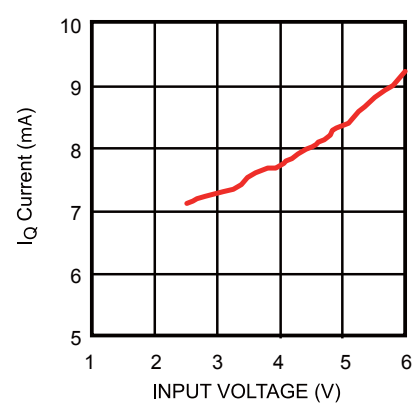

TYPICAL PERFORMANCE CHARACTERISTICS (continued)

C1=2.2µF, C2 =4.7µF, C3=1nF, T_A = +25°C, unless otherwise noted.

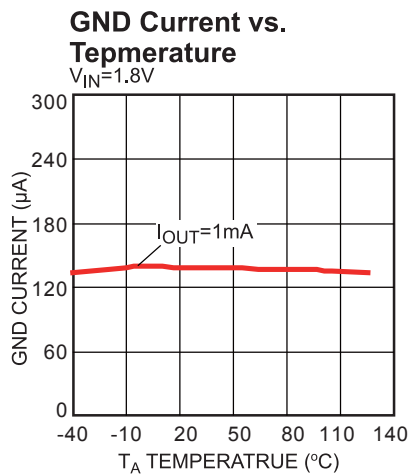
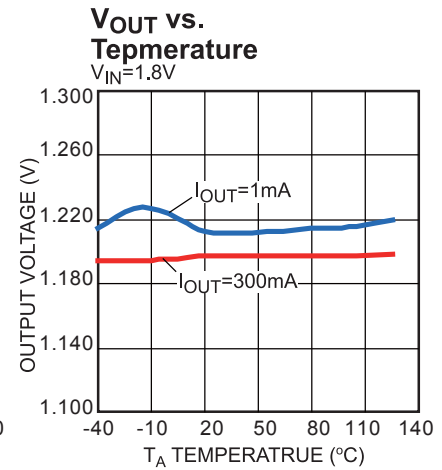
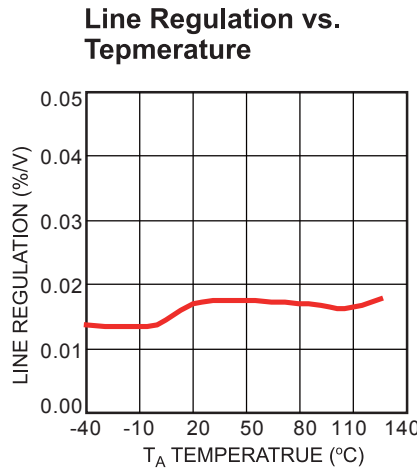
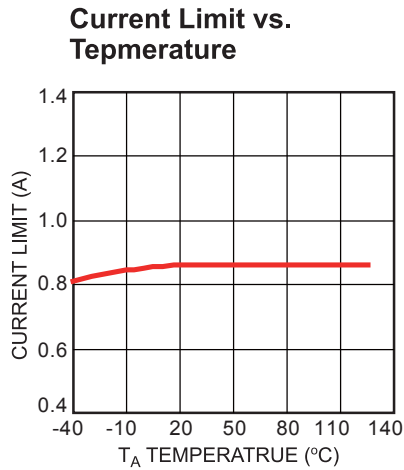
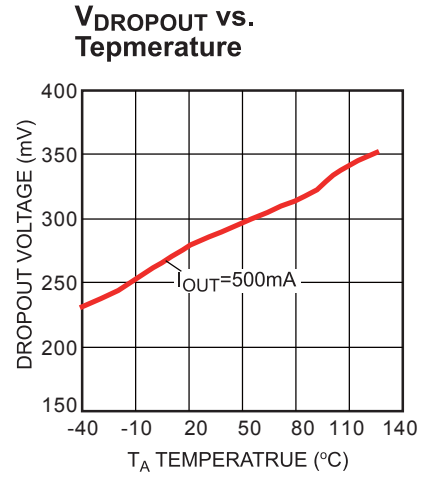
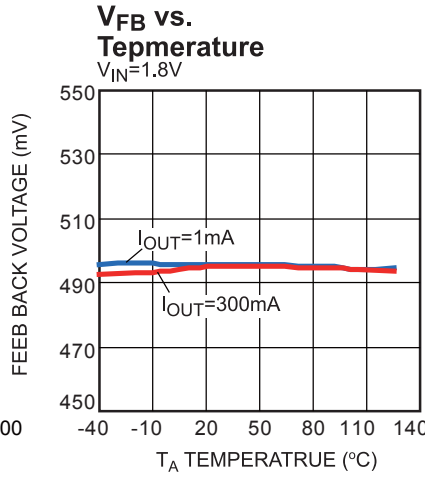
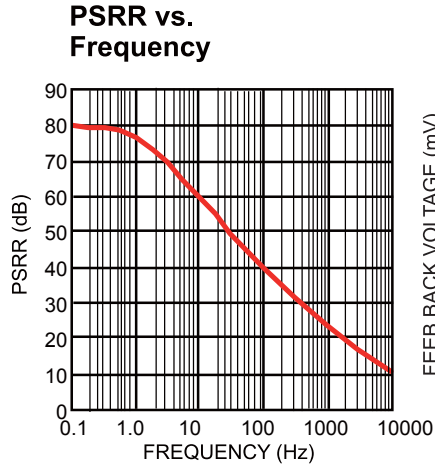

TYPICAL PERFORMANCE CHARACTERISTICS (continued)

C1=2.2µF, C2 =4.7µF, C3=1nF, T_A = +25°C, unless otherwise noted.

Line Transient

V_{IN} = 2.5V to 3.5V, V_O = 1.8V, V_{EN} = V_{IN},
I_{LOAD} = 50mA, with Resistor Load

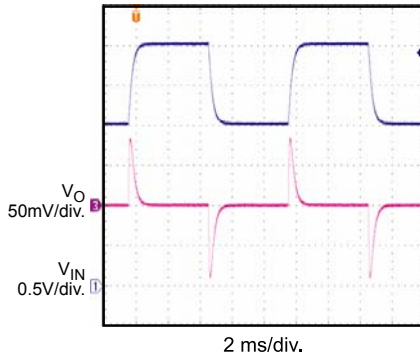

Load Transient

V_{IN} = 2.5V, V_O = 1.8V, V_{EN} = V_{IN},
I_{LOAD} = 50 to 300mA, with Resistor Load

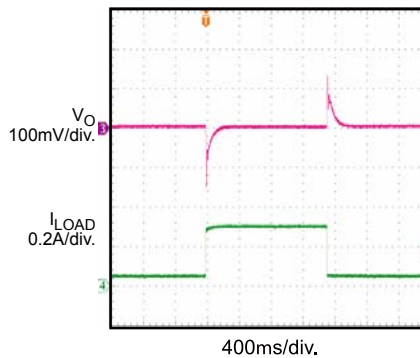

Enable Turn On

V_{IN} = 3.3V, V_O = 1.8V, V_{EN} = 0V - 2V,
I_O = 200mA, with Resistor Load

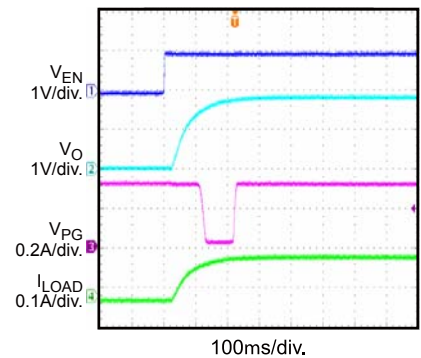

Enable Turn Off

V_{IN} = 3.3V, V_O = 1.8V, V_{EN} = 2V - 0V,
I_O = 200mA, with Resistor Load

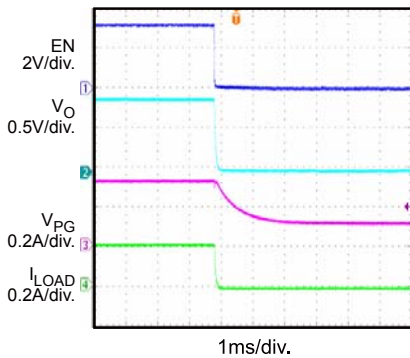

Thermal Protection

V_{IN} = V_{EN} = 5V,
V_O = 1.8V, I_{LOAD} = 0.5A

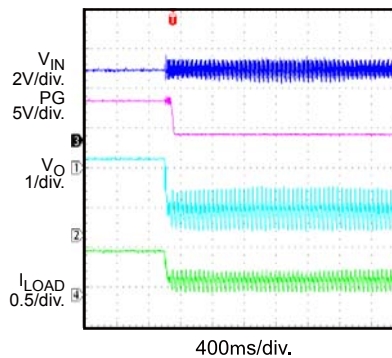

Short Circuit Protection

V_{IN} = 4V, V_O = 1.8V, V_{EN} = V_{IN}

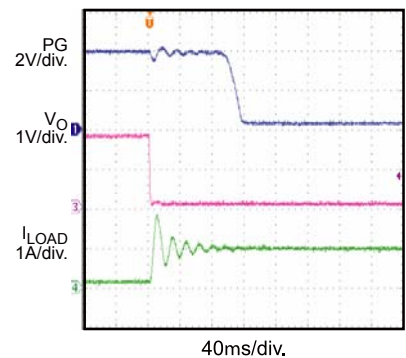

Short Circuit Recovery

V_{IN} = 4V, V_O = 1.8V, V_{IN} = V_{EN}

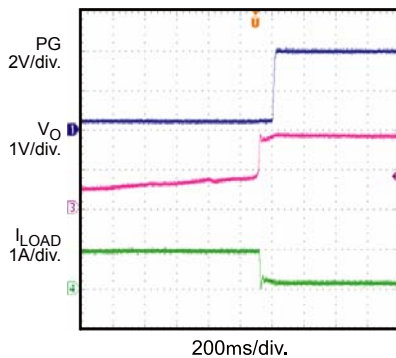

PIN FUNCTIONS

Pin #	Name	Description
1	OUT	Regulator Output. Bypass OUT to GND with a $\geq 4.7\mu\text{F}$ capacitor.
2	NC	No connect.
3	PG	Power-Good Open Collector Output. Monitors the regulator output. If the regulator output falls below 10% of its regulation point, the power-good pin goes low.
4	FB	Feedback. Connect a resistive voltage divider from OUT to FB to set the output voltage. OUT feedback threshold is 0.5V.
5	EN	Enable Input. Drive EN above 1.2V to turn on the MPQ8904. Drive EN below 0.4V to turn it off.
6	GND	Ground.
7	NC	No connect.
8	IN	Power Source Input. IN supplies the internal power to the MPQ8904 and is the source for the pass transistor. Bypass IN to GND with a $\geq 2.2\mu\text{F}$ capacitor.
Exposed Pad		Connect to GND.

OPERATION

The MPQ8904 is a low-current, low-voltage, low-dropout, linear regulator. It is intended for devices that require very low voltage and low quiescent current power, such as wireless modems and cellular phones.

The MPQ8904 uses a PNP pass element and features internal thermal shutdown and internal current limit circuit.

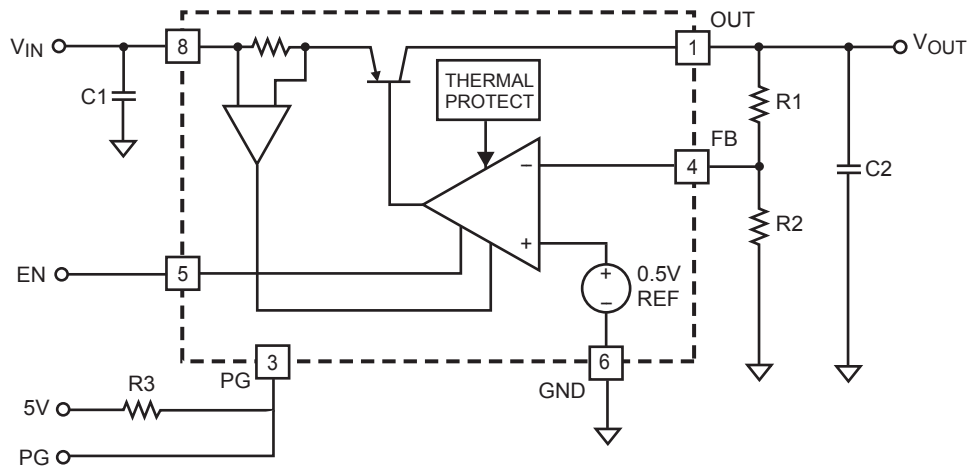

Figure 1: Functional Block Diagram

APPLICATION INFORMATION

Setting the Output Voltage

The MPQ8904 has an adjustable output voltage set via an external resistor divider (R1 and R2 in Figure 2).

$$R1 = R2 \times \left(\frac{V_{OUT} - V_{FB}}{V_{FB}} \right)$$

where $V_{FB} = 0.5V$ is the OUT feedback threshold voltage.

Example: For a 2.5V output and $R2=10k\Omega$

$$R1 = 10k \times \left(\frac{2.5 - 0.5}{0.5} \right) = 40k$$

Use a standard $40k\Omega (\pm 1\%)$ resistor for R1.

Table 1 lists selected R1 values for typical output voltages ($R2 = 10k\Omega$).

Power-Good

The power-good (PG) pin monitors the output voltage; if the output voltage goes below 10% of its regulation point, the PG pin goes low. The PG pin is an open collector output that connects to a pull-up resistor (typically $10k\Omega$). Tie the

pull-up resistor to 0V-to-5.5V supply, such as regulated input voltage.

Table 1: Adjustable Output Voltage Values vs. R1 ($R2 = 10k\Omega$)

$V_{OUT} (V)$	$R1 (\Omega)$
1.25	15k
1.5	20k
1.8	26k
2	30k
2.5	40k
2.8	46k
3	50k
3.3	56k
4	70k
5	90k

Bypass Capacitors

Bypass the reference voltage can be bypassed with an external capacitor to reduce noise. Use a low-ESR ceramic capacitor for the best performance.

TYPICAL APPLICATION CIRCUIT

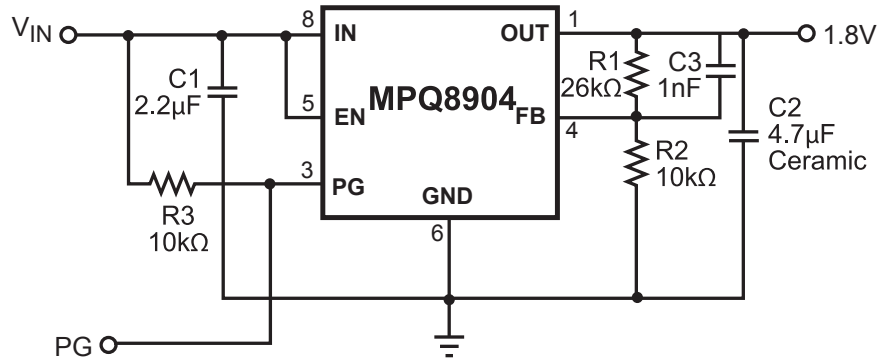

Figure 2: Typical Application Circuit

PCB layout guide

PCB layout is very important to achieve good regulation, ripple rejection, transient response and thermal performance. For optimal performance, duplicate the EVB layout from Figure 3.

For any changes, follow the guidelines below:

- 1) Place the input and output ceramic bypass capacitors close to their respective IN and OUT pins.
- 2) Use short and direct feedback connections. Place the feedback resistors and compensation components as close to the chip as possible.
- 3) Connect IN, OUT and GND to large copper surfaces to help cool the chip to improve thermal performance and long-term reliability.

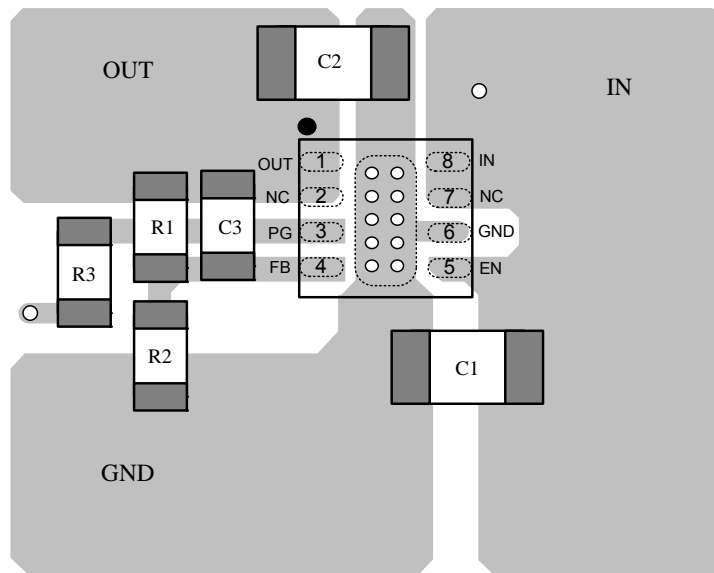
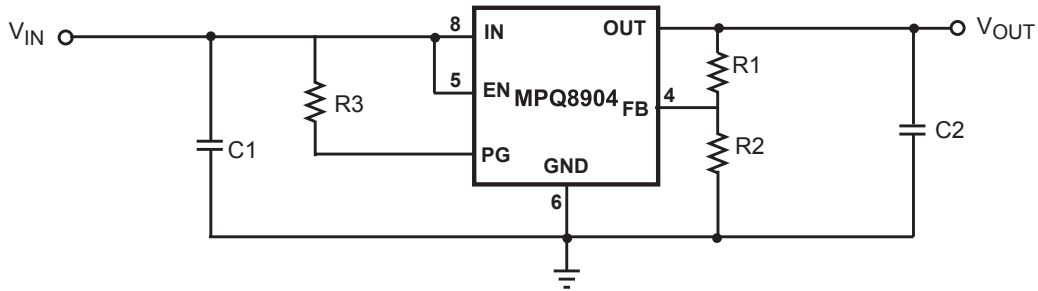
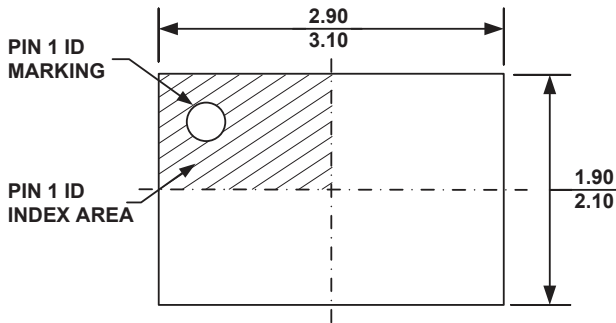

Figure 3: PCB Layout, Top Layer

PACKAGE INFORMATION

QFN8 (2mm x 3mm)



TOP VIEW

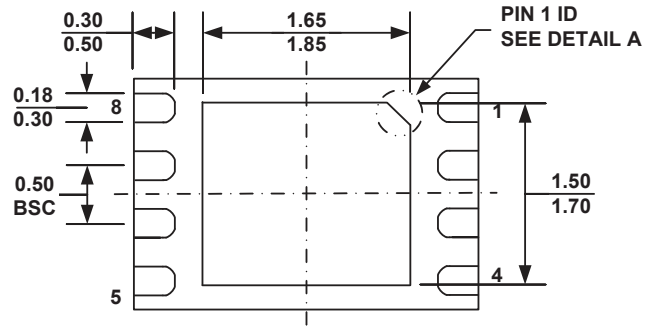

BOTTOM VIEW

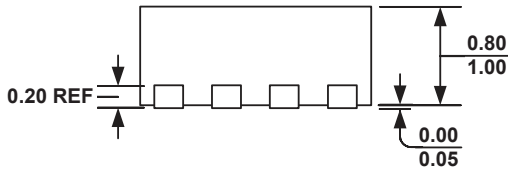

SIDE VIEW

PIN 1 ID OPTION A
0.30x45° TYP.

PIN 1 ID OPTION B
R0.20 TYP.



DETAIL A

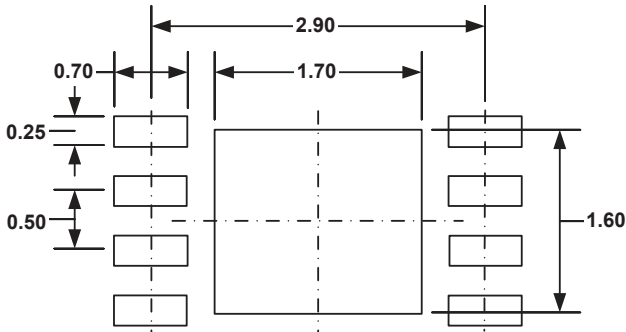

RECOMMENDED LAND PATTERN

NOTE:

- 1) ALL DIMENSIONS ARE IN MILLIMETERS.
- 2) EXPOSED PADDLE SIZE DOES NOT INCLUDE MOLD FLASH.
- 3) LEAD COPLANARITY SHALL BE 0.10 MILLIMETER MAX.
- 4) DRAWING CONFORMS TO JEDEC MO-229, VARIATION VCED-2.
- 5) DRAWING IS NOT TO SCALE.

NOTICE: The information in this document is subject to change without notice. Users should warrant and guarantee that third party Intellectual Property rights are not infringed upon when integrating MPS products into any application. MPS will not assume any legal responsibility for any said applications.



Компания «ЭлектроПласт» предлагает заключение долгосрочных отношений при поставках импортных электронных компонентов на взаимовыгодных условиях!

Наши преимущества:

- Оперативные поставки широкого спектра электронных компонентов отечественного и импортного производства напрямую от производителей и с крупнейших мировых складов;
- Поставка более 17-ти миллионов наименований электронных компонентов;
- Поставка сложных, дефицитных, либо снятых с производства позиций;
- Оперативные сроки поставки под заказ (от 5 рабочих дней);
- Экспресс доставка в любую точку России;
- Техническая поддержка проекта, помощь в подборе аналогов, поставка прототипов;
- Система менеджмента качества сертифицирована по Международному стандарту ISO 9001;
- Лицензия ФСБ на осуществление работ с использованием сведений, составляющих государственную тайну;
- Поставка специализированных компонентов (Xilinx, Altera, Analog Devices, Intersil, Interpoint, Microsemi, Aeroflex, Peregrine, Syfer, Eurofarad, Texas Instrument, Miteq, Cobham, E2V, MA-COM, Hittite, Mini-Circuits, General Dynamics и др.);

Помимо этого, одним из направлений компании «ЭлектроПласт» является направление «Источники питания». Мы предлагаем Вам помощь Конструкторского отдела:

- Подбор оптимального решения, техническое обоснование при выборе компонента;
- Подбор аналогов;
- Консультации по применению компонента;
- Поставка образцов и прототипов;
- Техническая поддержка проекта;
- Защита от снятия компонента с производства.



Как с нами связаться

Телефон: 8 (812) 309 58 32 (многоканальный)

Факс: 8 (812) 320-02-42

Электронная почта: org@eplast1.ru

Адрес: 198099, г. Санкт-Петербург, ул. Калинина, дом 2, корпус 4, литера А.