



ON Semiconductor®

<http://onsemi.com>

LC898201

CMOS LSI

Iris/Zoom/Focus/ Day-Night switching Drive Controller

Overview

LC898201 is the appropriate motor control LSI for the surveillance camera usage, and it can drive iris, focus, zoom and Day/Night switching simultaneously.

It incorporates two feedback circuits for iris and focus control, and two stepper motor control circuits for zoom and Day/Night switching (cf. P4 Application-1).

Moreover, the feedback control applies iris control, and stepper motor controls apply focus, zoom and Day/Night switching at the mode selection (cf. Application-2 to 4 of P5 to P7).

Stepper motor control circuits can drive the stepping motor efficiently (It is called "ECO(GREEN)-driver") (For a limited numerical usable channel, refer to Application-1 to 4 of P4 to P7).

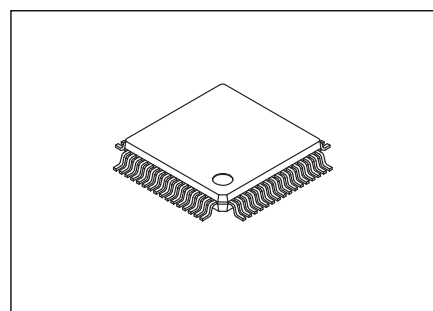

TQFP64 7x7
[LC898201TA-NH]

Features

- Built-in equalizer circuit by digital operation
 - Iris control equalizer circuit
 - Focus control equalizer circuit (MR sensor can be connected.)
 - Coefficients can be set arbitrarily through the SPI interface.
 - Computed values in the equalizer can be monitored.
- Built-in 3ch stepping motor control circuits
(2ch are equipped with "ECO(GREEN)-driver" circuits)
(Usable channel is shown in Application-1 to 4 of P4 to P7)
- SPI bus interface
- PI control circuit
 - 30mA Sink output terminal
 - Built-in PI detecting function (A/D method)
- A/D converter
 - 12bit (6ch)
 - : Iris, Focus, ECO, PI detection
- D/A converter
 - 8bit (5ch)
 - : Hall offset, Constant current bias, MR Sensor offset, ECO offset
- Operation Amplifier
 - 4ch (ECO ×1, Iris control ×1, Focus control ×2)

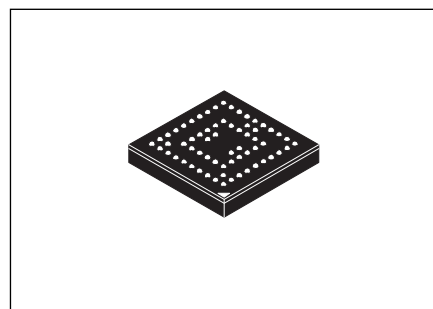

FBGA64 6x6
[LC898201RA-NH]

To the next page.

ORDERING INFORMATION

See detailed ordering and shipping information on page 16 of this data sheet.

LC898201

- PWM pulse generator
 - PWM Pulse generator for feedback control (Up to 12bit accuracy)
 - PWM pulse generator for stepper motor control (Up to 1024 micro steps)
 - PWM pulse generator for general-purpose H-Bridge (128 voltage levels)
- Motor Driver
 - ch1 to ch6 : I_o max=200mA
 - ch7 : I_o max=300mA
 - Built-in thermal protection circuit
 - Built-in low-voltage malfunction prevention circuit
- OSC (Type. 48MHz)
- Package
 - LC898201TA-NH : TQFP64(7×7) 0.4mm pitch
 - LC898201RA-NH : FBGA64(6.0×6.0) 0.5mm pitch
 - Lead-free, Halogen-free
- Power supply voltage
 - Logic unit : 2.7V to 3.6V (IO, Internal core)
 - Driver unit : 2.7V to 5.5V (Motor drive)

Package Dimensions

unit : mm

[LC898201TA-NH]

TQFP64 7x7 / TQFP64
CASE 932BC
ISSUE 0

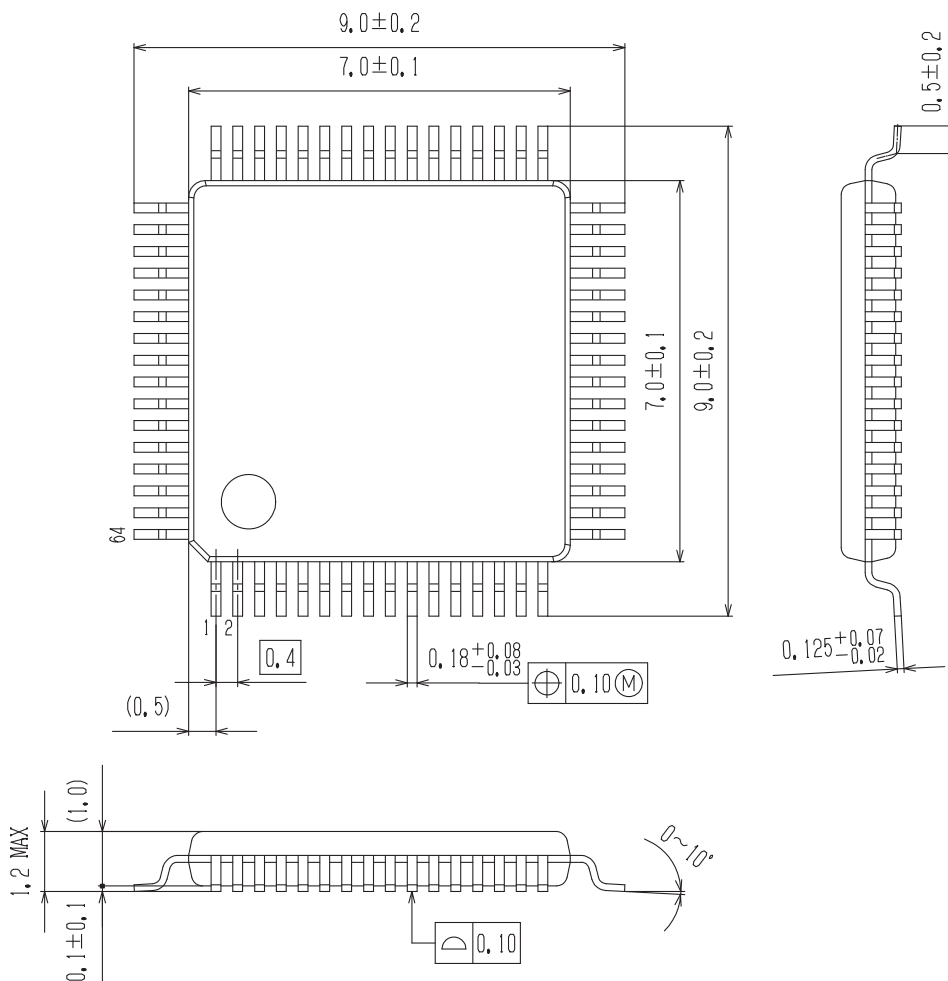

Package Dimensions

unit : mm

[LC898201RA-NH]

FBGA64 6x6
CASE 113BL
ISSUE O

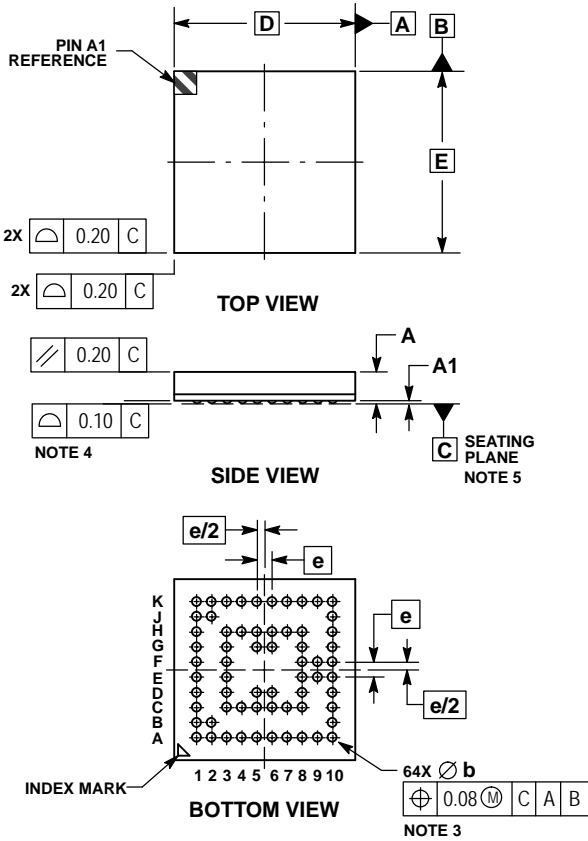

NOTES:

1. DIMENSIONING AND TOLERANCING PER ASME Y14.5M, 1994.
2. CONTROLLING DIMENSION: MILLIMETERS.
3. DIMENSION b IS MEASURED AT THE MAXIMUM SOLDER BALL DIAMETER PARALLEL TO DATUM C.
4. COPLANARITY APPLIES TO SPHERICAL CROWNS OF SOLDER BALLS.
5. DIMENSION C, THE SEATING PLANE, IS DEFINED BY THE SPHERICAL CROWNS OF THE SOLDER BALLS.

DIM	MILLIMETERS	
	MIN	MAX
A	---	1.05
A1	0.05	0.15
b	0.24	0.34
D	6.00 BSC	
E	6.00 BSC	
e	0.50 BSC	

RECOMMENDED SOLDERING FOOTPRINT*

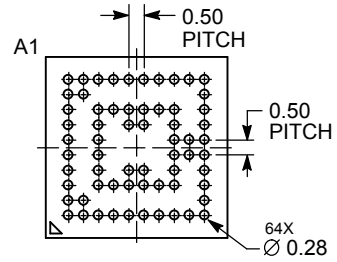

DIMENSIONS: MILLIMETERS

*For additional information on our Pb-Free strategy and soldering details, please download the ON Semiconductor Soldering and Mounting Techniques Reference Manual, SOLDERRM/D.

LC898201

Block Diagram Application-1 MR-VCM

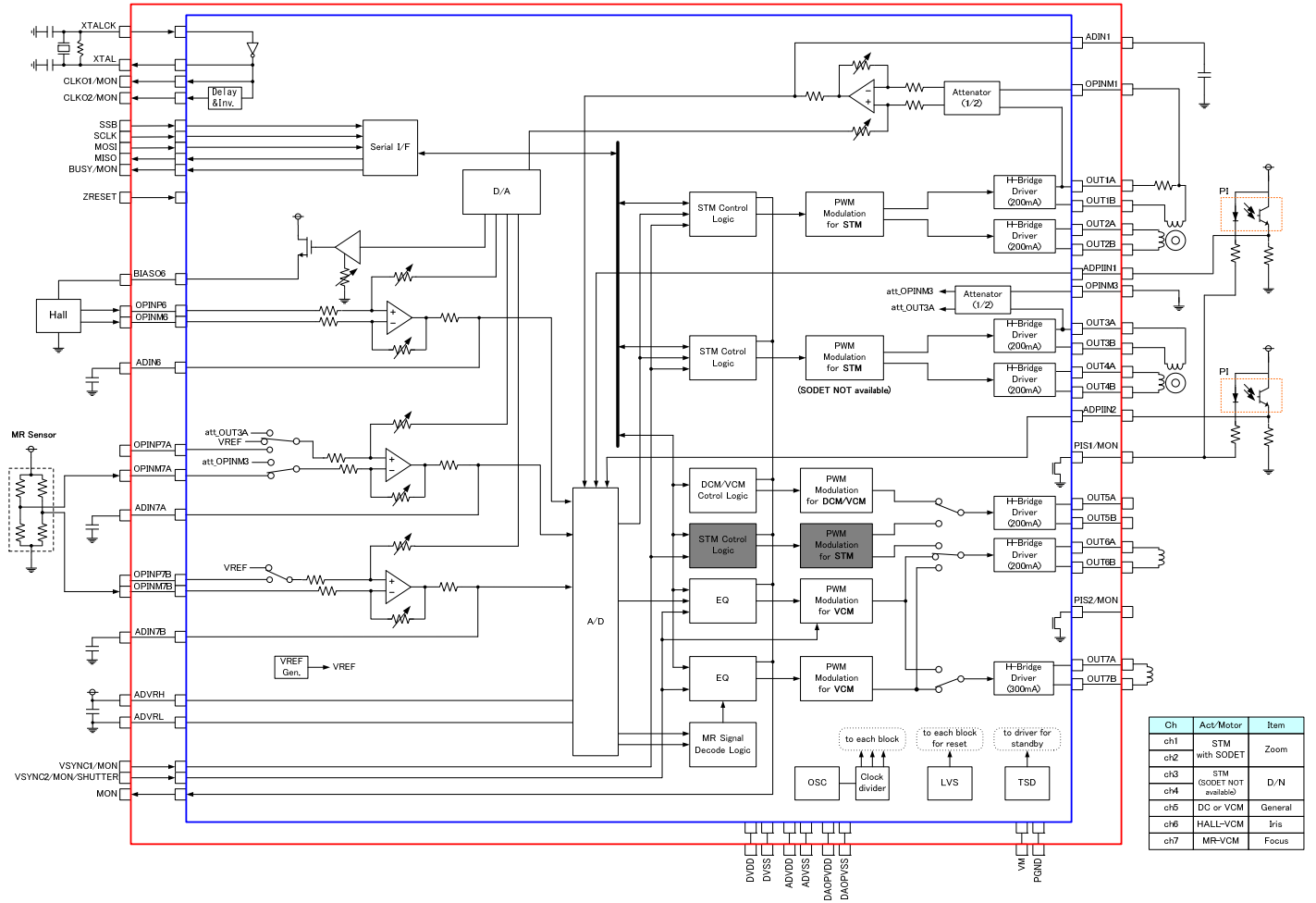

Ch	Act/Motor	Item
ch1	STM with SODET	Zoom
ch3	STM (SODET NOT available)	D/N
ch6	DC or VCM	General
ch6	HALL-VCM	Iris
ch7	MR-VCM	Focus

LC898201

Application-2

Stepper Motor 3ch & Crystal oscillator(or Ceramic oscillator)

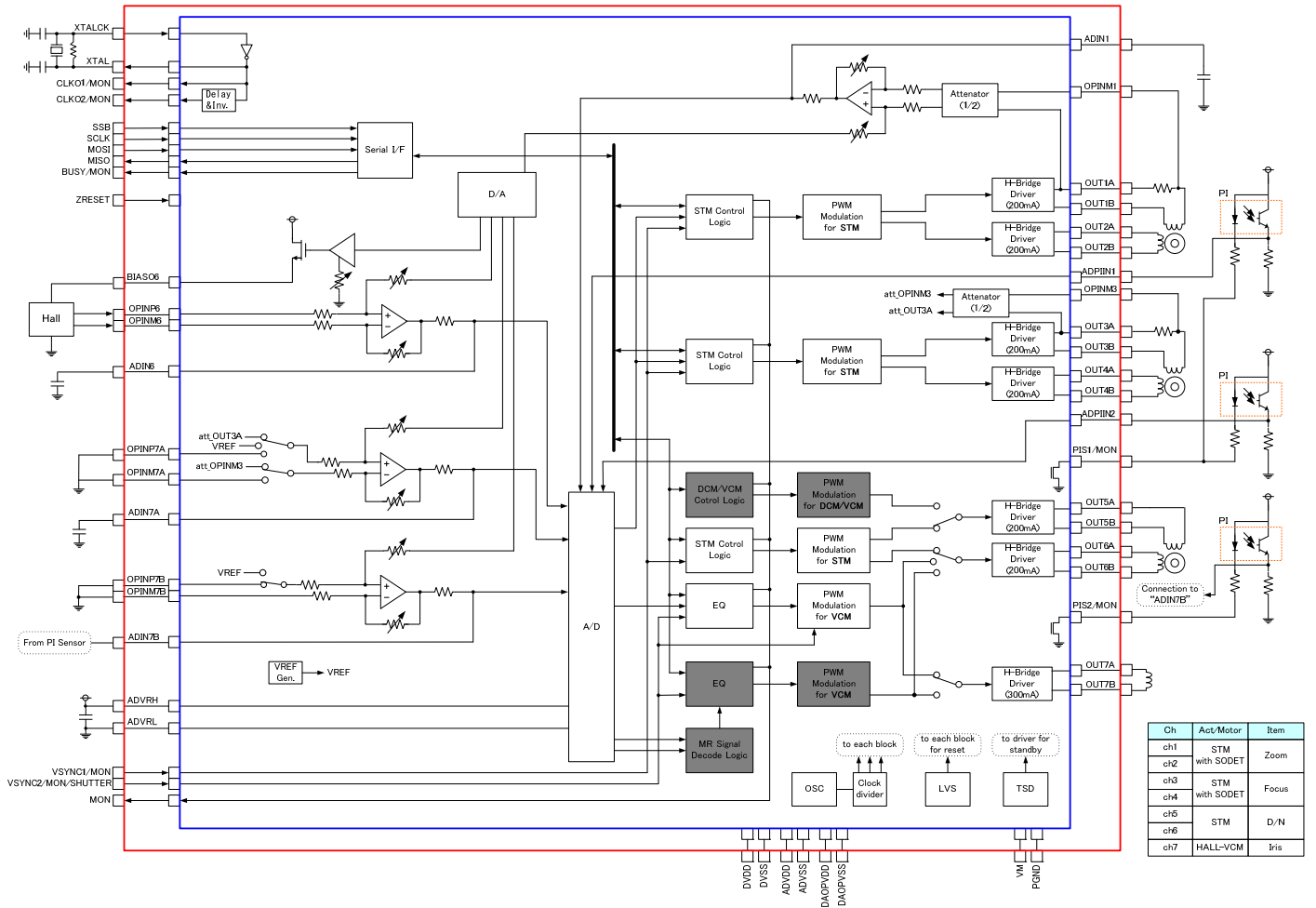

Application-3 Stepper Motor 3ch & Oscillator

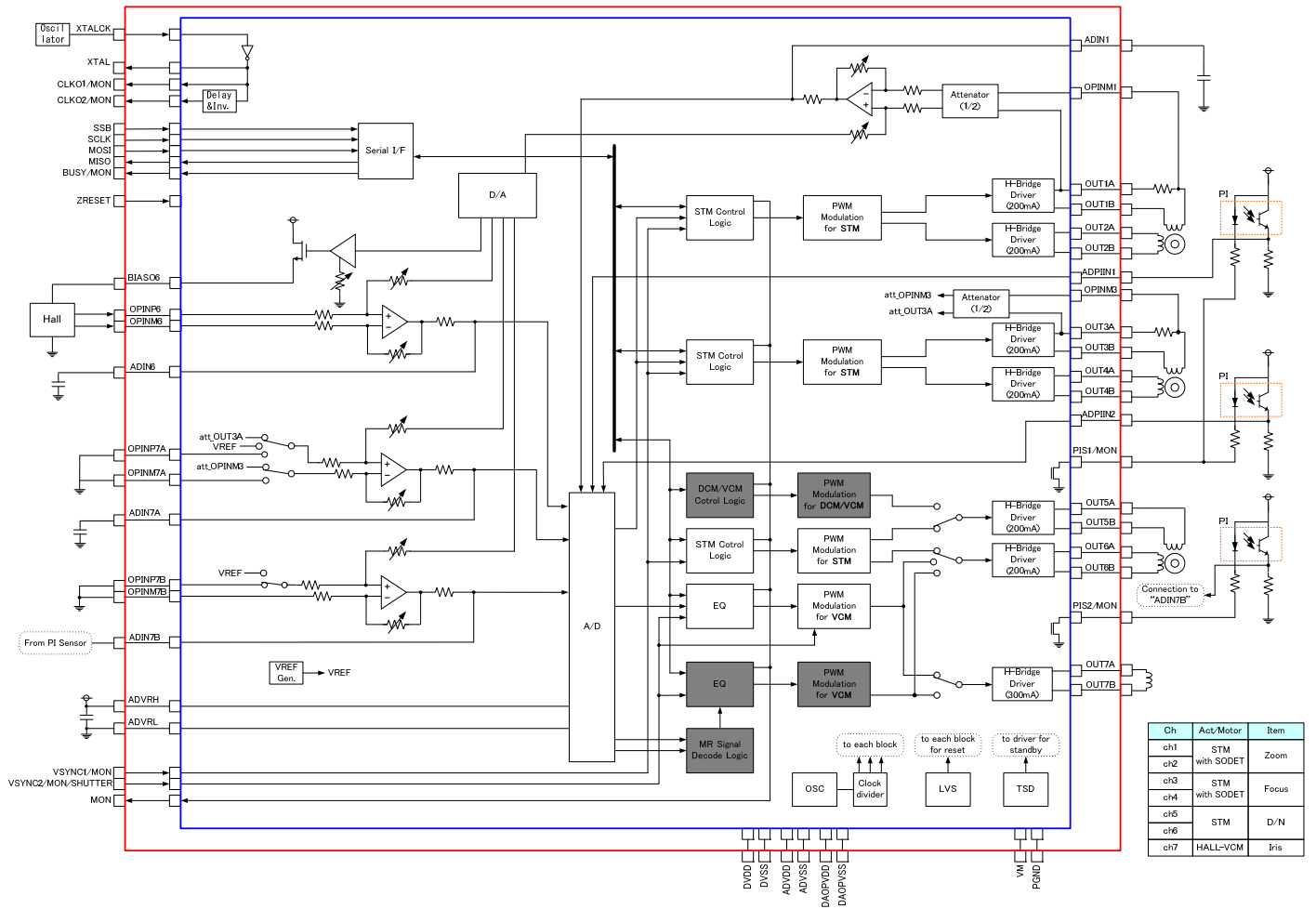

Application-4

Stepper Motor 3ch & ECO external connection

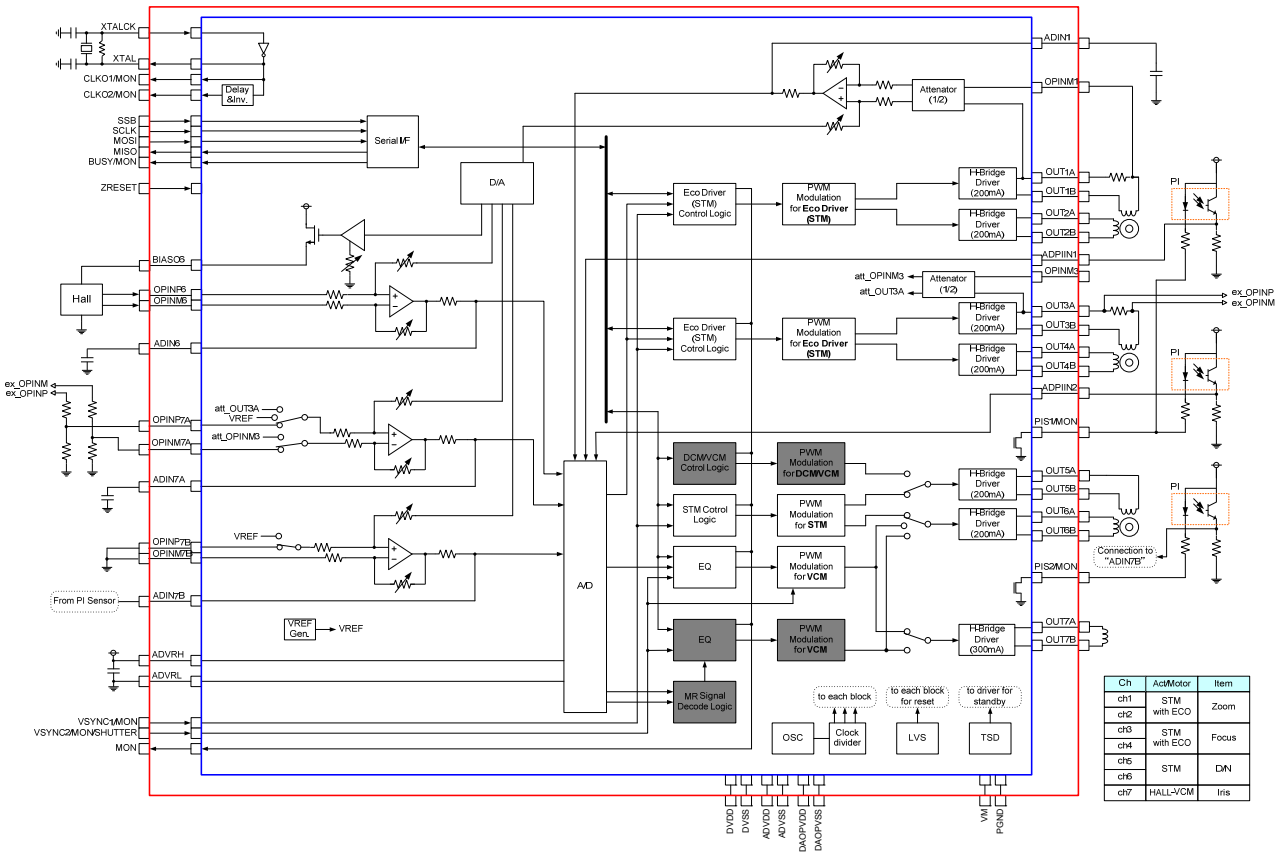

Pin Description

TYPE					
I	INPUT	P	Power, GND	NC	NOT CONNECT
O	OUTPUT				
B(I)	BIDIRECTION : INPUT at reset				
B(O)	BIDIRECTION : OUTPUT at reset				

■ SPI interface (Slave)

SSB	I	Chip select
SCLK	I	Clock
MOSI	I	Received data
MISO	B(O)	Transmit data
BUSY/MON	B(O)	Transfer busy / Monitor output

■ PI sensor drive signal output

PIS1/MON	B(O)	PI sensor drive signal output 1 / Monitor output
PIS2/MON	B(O)	PI sensor drive signal output 2 / Monitor output

■ Video synchronizing signal input

VSYNC1/MON	B(I)	Video synchronizing signal input / Monitor output (with pull-down resistance)
VSYNC2/MON /SHUTTER	B(I)	Video synchronizing signal input / Monitor output / Shutter input (with pull-down resistance)

■ Monitor output

MON	B(O)	Monitor output
-----	------	----------------

■ Clock output

XTALCK	I	Oscillation amplifier input : 27MHz
XTAL	O	Oscillation amplifier output
CLKO1/MON	B(O)	Clock output 1 / Monitor output
CLKO2/MON	B(O)	Clock output 2 / Monitor output

■ Reset

ZRESET	I	Reset signal input(Low active)
--------	---	--------------------------------

■ Bias current pin

BIASO6	O	CH6 Bias current output
--------	---	-------------------------

■ OP Amp pin

OPINM1	I	CH1 OP Amp input(-) with ATT
OPINM3	I	CH3 OP Amp input(-) with ATT
OPINP6	I	CH6 OP Amp input (+)
OPINM6	I	CH6 OP Amp input (-)
OPINP7A	I	CH7-A OP Amp input (+)
OPINM7A	I	CH7-A OP Amp input (-)
OPINP7B	I	CH7-B OP Amp input (+)
OPINM7B	I	CH7-B OP Amp input (-)

■ A/D input pin

ADIN1	B	CH1 A/D input (CH1 OP Amp output)
ADIN6	B	CH6 A/D input (CH6 OP Amp output)
ADIN7A	B	CH7-A A/D input (CH7 OP Amp output)
ADIN7B	B	CH7-B A/D input (CH7 OP Amp output)
ADPIIN1	I	CH1/2 PI sensor signal A/D input
ADPIIN2	I	CH3/4 PI sensor signal A/D input
ADVRH	I	A/D conversion range standard voltage
ADVRL	I	A/D conversion range standard voltage

■ H-Bridge

OUT1A	O	CH1 H-Bridge output
OUT1B	O	CH1 H-Bridge output
OUT2A	O	CH2 H-Bridge output
OUT2B	O	CH2 H-Bridge output
OUT3A	O	CH3 H-Bridge output
OUT3B	O	CH3 H-Bridge output
OUT4A	O	CH4 H-Bridge output
OUT4B	O	CH4 H-Bridge output
OUT5A	O	CH5 H-Bridge output
OUT5B	O	CH5 H-Bridge output
OUT6A	O	CH6 H-Bridge output
OUT6B	O	CH6 H-Bridge output
OUT7A	O	CH7 H-Bridge output
OUT7B	O	CH7 H-Bridge output

■ Power pin

DVDD	P	Digital VDD
DVSS	P	Digital GND
DAOPVDD	P	D/A, OP Amp VDD
DAOPVSS	P	D/A, OP Amp GND
ADVDD	P	A/D VDD
ADVSS	P	A/D GND
VM	P	H-Bridge VDD
PGND	P	H-Bridge GND

*** Process when pins are not used**

PIN TYPE “O” The pin must be left open.

PIN TYPE “I” The pin must not be left open. Please make sure to connect the pin to Vdd or Vss even when it is not used. (Please check with us whether to connect to Vdd or Vss.)

PIN TYPE “B” Please contact us if you are uncertain about a processing method in the pin description in the PIN layout table.

A problem may occur if the processing method is used wrongly for any unused pin.

Please make sure to contact us.

Pin Assignment

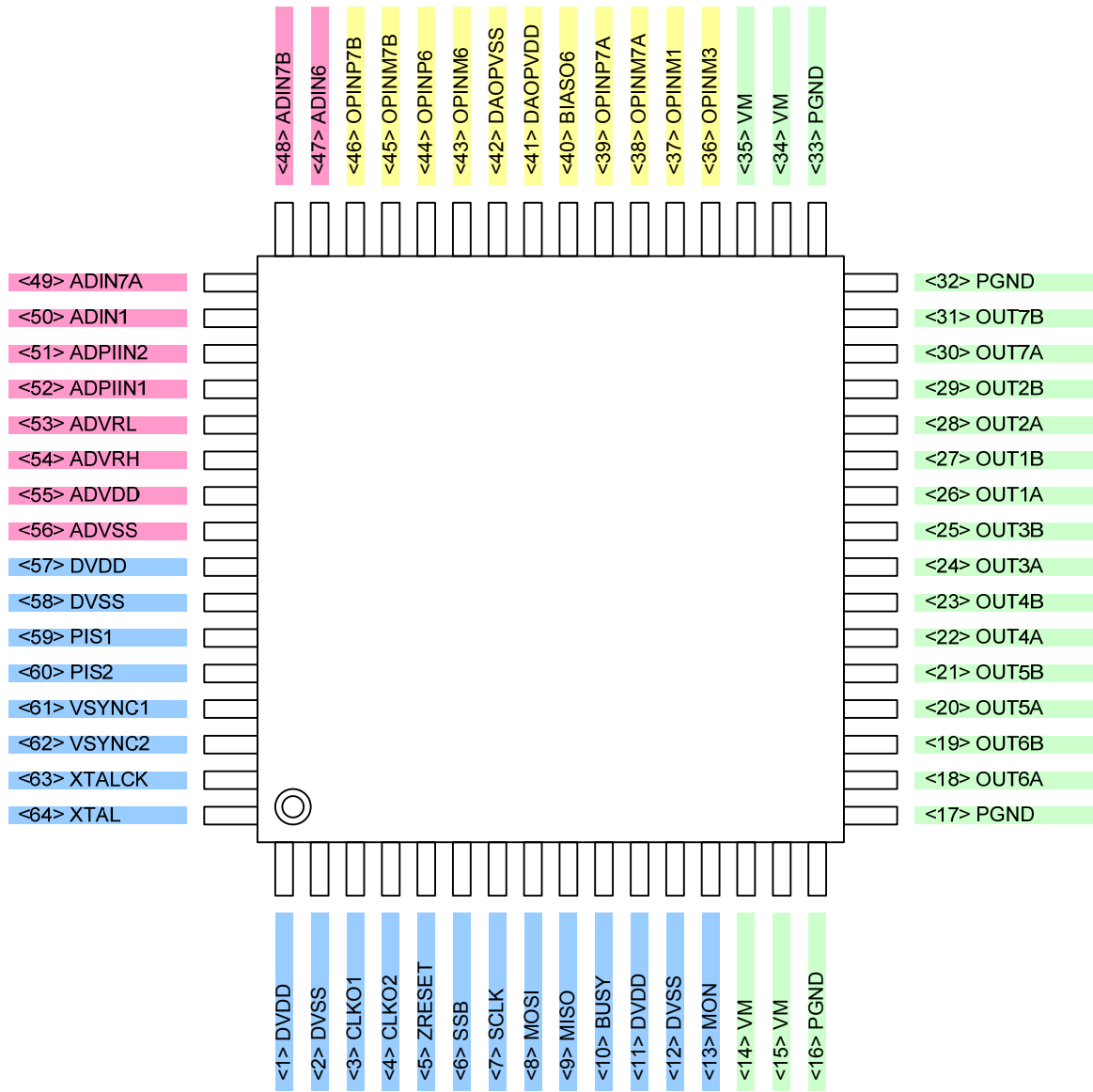

<TOP VIEW> TQFP64(7X7)

LC898201

10	DVDD	VSYNC2	PIS2	DVSS	ADVSS	ADVDD	ADPI IN1	ADPI IN2	ADIN7A	ADIN7B
9	DVSS				ADVRL	ADVRH				ADIN6
8	CLKO1		XTALCK	VSYNC1	PIS1	DVDD	ADIN1	OPINM 7B		OPINP 7B
7	CLKO2		XTAL					OPINM6		OPINP6
6	SSB		ZRESET	SCLK			BIASO6	DAOP VSS		DAOP VDD
5	MISO		BUSY	MOSI			OPINM1	OPINP 7A		OPINM 7A
4	DVDD		DVSS					OPINM3		OUT7A
3	MON		OUT6A	OUT5A	OUT4A	OUT3A	OUT1A	OUT2A		OUT7B
2	VM	VM							VM	VM
1	PGND	PGND	OUT6B	OUT5B	OUT4B	OUT3B	OUT1B	OUT2B	PGND	PGND
	A	B	C	D	E	F	G	H	J	K

<TOP VIEW> FBGA64(6.0X6.0)

PIN number

Pin No.		Type	Pin name
TQFP64	FBGA64		
1	A10	P	DVDD
2	A9	P	DVSS
3	A8	B(O)	CLKO1
4	A7	B(O)	CLKO2
5	C6	I	ZRESET
6	A6	I	SSB
7	D6	I	SCLK
8	D5	I	MOSI
9	A5	B(O)	MISO
10	C5	B(O)	BUSY
11	A4	P	DVDD
12	C4	P	DVSS
13	A3	B(O)	MON
14	B2	P	VM
15	A2	P	VM
16	B1	P	PGND

Pin No.		Type	Pin name
TQFP64	FBGA64		
33	J1	P	PGND
34	J2	P	VM
35	K2	P	VM
36	H4	I	OPINM3
37	G5	I	OPINM1
38	K5	I	OPINM7A
39	H5	I	OPINP7A
40	G6	O	BIASO6
41	K6	P	DAOPVDD
42	H6	P	DAOPVSS
43	H7	I	OPINM6
44	K7	I	OPINP6
45	H8	I	OPINM7B
46	K8	I	OPINP7B
47	K9	B	ADIN6
48	K10	B	ADIN7B

Pin No.		Type	Pin name
TQFP64	FBGA64		
17	A1	P	PGND
18	C3	O	OUT6A
19	C1	O	OUT6B
20	D3	O	OUT5A
21	D1	O	OUT5B
22	E3	O	OUT4A
23	E1	O	OUT4B
24	F3	O	OUT3A
25	F1	O	OUT3B
26	G3	O	OUT1A
27	G1	O	OUT1B
28	H3	O	OUT2A
29	H1	O	OUT2B
30	K4	O	OUT7A
31	K3	O	OUT7B
32	K1	P	PGND

Pin No.		Type	Pin name
TQFP64	FBGA64		
49	J10	B	ADIN7A
50	G8	B	ADIN1
51	H10	I	ADPIIN2
52	G10	I	ADPIIN1
53	E9	I	ADVRL
54	F9	I	ADVRH
55	F10	P	ADVDD
56	E10	P	ADVSS
57	F8	P	DVDD
58	D10	P	DVSS
59	E8	B(O)	PIS1
60	C10	B(O)	PIS2
61	D8	B(I)	VSYNC1
62	B10	B(I)	VSYNC2
63	C8	I	XTALCK
64	C7	O	XTAL

Electrical Characteristics

1. Logic, Analog

Logic, Analog power : DVDD/DVSS, OPDAVDD/OPDAVSS, ADVDD/ADVSS, these should be connected at the same voltage. They are shown DVDD/DVSS as follows.

1) Absolute Maximum Ratings at DVSS=0V

Parameter	Symbol	Conditions	Ratings	Unit
Supply Voltage	DVDD max	Ta ≤ 25°C	-0.3 to 4.6	V
Input/Output Voltage	Vin, Vout	Ta ≤ 25°C	-0.3 to DVDD+0.3	V
Storage Temperature	Tstg		-55 to 125	°C
Operating Temperature	Topr		-20 to 85	°C

Stresses exceeding those listed in the Maximum Ratings table may damage the device. If any of these limits are exceeded, device functionality should not be assumed, damage may occur and reliability may be affected.

2) Allowable Operating Range at Ta=-20 to 85°C, DVSS=0V

Parameter	Symbol	Min.	Typ.	Max.	Unit	Applicable pins
Power Supply Voltage	DVDD	2.7	3.3	3.6	V	
Input Voltage Range	VIN	0	-	DVDD	V	Except for OPINM1, OPINM3
Input Voltage Range	VIN	0	-	VM	V	OPINM1, OPINM3

Functional operation above the stresses listed in the Recommended Operating Ranges is not implied. Extended exposure to stresses beyond the Recommended Operating Ranges limits may affect device reliability.

3) D.C Characteristics : Input/Output level at Ta=-20 to 85°C, DVSS=0V, DVDD=2.7 to 3.6V

Parameter	Symbol	Conditions	Min.	Typ.	Max.	Unit	Applicable pins
High-level input voltage	VIH	CMOS	0.7DVDD			V	(2)(3)
Low-level input voltage	VIL				0.2DVDD	V	
High-level input voltage	VIH	CMOS Schmidt	0.75DVDD			V	(1)
Low-level input voltage	VIL				0.15DVDD	V	
High-level output voltage	VOH	IOH=-4mA	DVDD-0.4			V	(2)(3)(4)
Low-level output voltage	VOL	IOL= 4mA			0.4	V	(2)(3)
Low-level output voltage	VOL	IOL= 30mA			0.4	V	(4)
PullDown resistance	Rdn		40	80	200	KΩ	(3)
Analog input voltage	VAI		DVSS		DVDD	V	(5)
Analog input voltage	VAI		PGND		VM	V	(6)
VGA output resistance	Rout			1		KΩ	(7)
Analog output current	IAO	CMSDAC =001b & WH_DAV4 =00h		1		mA	(8)

* Applicable pins

- (1) ZRESET, SSB, SCLK, MOSI
- (2) MISO, BUSY, MON, CLK01, CLK02
- (3) VSYNC1, VSYNC2
- (4) PIS1, PIS2
- (5) OPINP6, OPINM6, OPINP7A, OPINM7A, OPINP7B, OPINM7B, ADPIIN1, ADPIIN2
- (6) OPINM1, OPINM3
- (7) ADIN1, ADIN6, ADIN7A, ADIN7B
- (8) BIASO6

Product parametric performance is indicated in the Electrical Characteristics for the listed test conditions, unless otherwise noted. Product performance may not be indicated by the Electrical Characteristics if operated under different conditions.

LC898201

2. VM

1) Absolute Maximum Ratings at Ta=25°C, PGND=0V

Parameter	Symbol	Conditions	Ratings	Unit
Supply Voltage	VMmax		-0.3 to 7.0	V
Output peak current	Iopeak1	OUT1A/B to OUT6A/B t ≤ 10ms, On-duty ≤ 20%	300	mA
Output peak current	Iopeak2	OUT7A/B t ≤ 10ms, On-duty ≤ 20%	450	mA
Output continuous current	Iomax1	OUT1A/B to OUT6A/B	200	mA
Output continuous current	Iomax2	OUT7A/B	300	mA
Storage Temperature	Tstg		-55 to 125	°C
Operating Temperature	Topr		-20 to 85	°C

Stresses exceeding those listed in the Maximum Ratings table may damage the device. If any of these limits are exceeded, device functionality should not be assumed, damage may occur and reliability may be affected.

2) Allowable Operating Range at Ta=25°C, PGND=0V

Item	Symbol	Conditions	Ratings	Unit
Power Supply Voltage	VM		2.7 to 5.5	V

Functional operation above the stresses listed in the Recommended Operating Ranges is not implied. Extended exposure to stresses beyond the Recommended Operating Ranges limits may affect device reliability.

3) Electrical Characteristics at Ta=25°C, PGND=0V, VM=5V

Parameter	Symbol	Conditions	Min.	Typ.	Max.	Unit	Applicable pins
Output ON resistance	Ronu	I _o =200mA Pch		0.85		Ω	(9)
	Rond	I _o =200mA Nch		0.45		Ω	
Output ON resistance	Ronu	I _o =300mA Pch		0.85		Ω	(10)
	Rond	I _o =300mA Nch		0.45		Ω	
Diode forward voltage	VD	I _D =-200mA		0.9		V	(9)
Diode forward voltage	VD	I _D =-300mA		0.9		V	(10)

* Applicable pins

(9) OUT1A, OUT1B, OUT2A, OUT2B, OUT3A, OUT3B, OUT4A, OUT4B, OUT5A, OUT5B, OUT6A, OUT6B

(10) OUT7A, OUT7B

Product parametric performance is indicated in the Electrical Characteristics for the listed test conditions, unless otherwise noted. Product performance may not be indicated by the Electrical Characteristics if operated under different conditions.

Example of External Circuit

Connection example of oscillation circuit

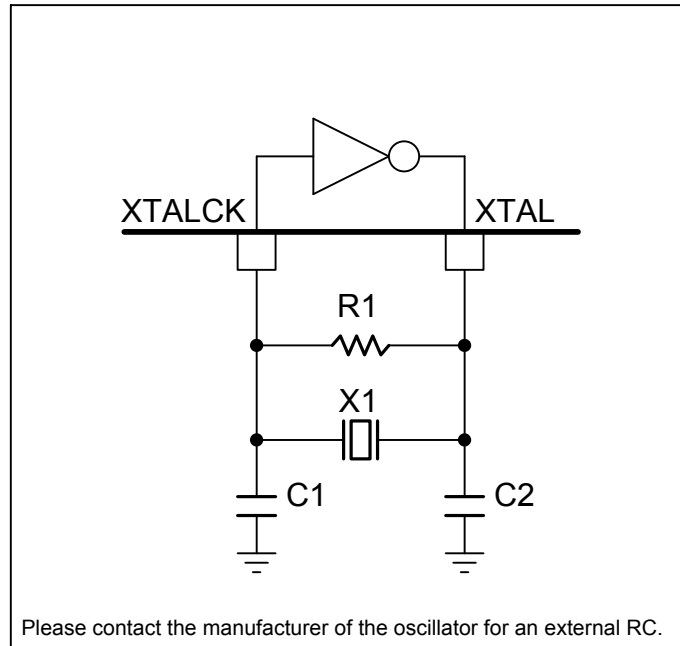

* In the case of X'tal, it takes about 50 ms for oscillation to stabilize (please check with the manufacturer for a precise time period).

AC Characteristics

Power supply, Reset pin

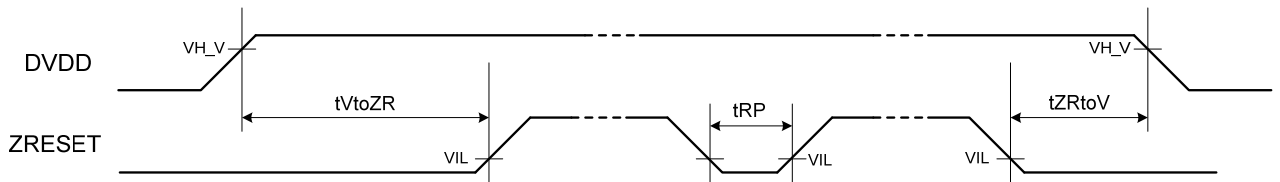

Specification

DVDD : DVDD, OPDAVDD, ADVDD
 VH_V : 2.7V
 VIL : 0.15×DVDD

Parameter	Symbol	Min.	Typ.	Max.	Unit
The time from the rise of DVDD to the rise of ZRESET	tVtoZR	1			ms
The time from the fall of DVDD to the fall of ZRESET	tZRtoV	500			μs
Low period of ZRESET	tRP	100			μs

VM can be turn on/off regardless above power supply AC timing.

ORDERING INFORMATION

Device	Package	Shipping (Qty / Packing)
LC898201TA-NH	TQFP64 7x7 (Pb-Free / Halogen Free)	1000 / Tape & Reel
LC898201RA-NH	FBGA64 6x6 (Pb-Free / Halogen Free)	1000 / Tape & Reel

ON Semiconductor and the ON logo are registered trademarks of Semiconductor Components Industries, LLC (SCILLC) or its subsidiaries in the United States and/or other countries. SCILLC owns the rights to a number of patents, trademarks, copyrights, trade secrets, and other intellectual property. A listing of SCILLC's product/patent coverage may be accessed at www.onsemi.com/site/pdf/Patent-Marking.pdf. SCILLC reserves the right to make changes without further notice to any products herein. SCILLC makes no warranty, representation or guarantee regarding the suitability of its products for any particular purpose, nor does SCILLC assume any liability arising out of the application or use of any product or circuit, and specifically disclaims any and all liability, including without limitation special, consequential or incidental damages. "Typical" parameters which may be provided in SCILLC data sheets and/or specifications can and do vary in different applications and actual performance may vary over time. All operating parameters, including "Typicals" must be validated for each customer application by customer's technical experts. SCILLC does not convey any license under its patent rights nor the rights of others. SCILLC products are not designed, intended, or authorized for use as components in systems intended for surgical implant into the body, or other applications intended to support or sustain life, or for any other application in which the failure of the SCILLC product could create a situation where personal injury or death may occur. Should Buyer purchase or use SCILLC products for any such unintended or unauthorized application, Buyer shall indemnify and hold SCILLC and its officers, employees, subsidiaries, affiliates, and distributors harmless against all claims, costs, damages, and expenses, and reasonable attorney fees arising out of, directly or indirectly, any claim of personal injury or death associated with such unintended or unauthorized use, even if such claim alleges that SCILLC was negligent regarding the design or manufacture of the part. SCILLC is an Equal Opportunity/Affirmative Action Employer. This literature is subject to all applicable copyright laws and is not for resale in any manner.



Компания «ЭлектроПласт» предлагает заключение долгосрочных отношений при поставках импортных электронных компонентов на взаимовыгодных условиях!

Наши преимущества:

- Оперативные поставки широкого спектра электронных компонентов отечественного и импортного производства напрямую от производителей и с крупнейших мировых складов;
- Поставка более 17-ти миллионов наименований электронных компонентов;
- Поставка сложных, дефицитных, либо снятых с производства позиций;
- Оперативные сроки поставки под заказ (от 5 рабочих дней);
- Экспресс доставка в любую точку России;
- Техническая поддержка проекта, помощь в подборе аналогов, поставка прототипов;
- Система менеджмента качества сертифицирована по Международному стандарту ISO 9001;
- Лицензия ФСБ на осуществление работ с использованием сведений, составляющих государственную тайну;
- Поставка специализированных компонентов (Xilinx, Altera, Analog Devices, Intersil, Interpoint, Microsemi, Aeroflex, Peregrine, Syfer, Eurofarad, Texas Instrument, Miteq, Cobham, E2V, MA-COM, Hittite, Mini-Circuits, General Dynamics и др.);

Помимо этого, одним из направлений компании «ЭлектроПласт» является направление «Источники питания». Мы предлагаем Вам помощь Конструкторского отдела:

- Подбор оптимального решения, техническое обоснование при выборе компонента;
- Подбор аналогов;
- Консультации по применению компонента;
- Поставка образцов и прототипов;
- Техническая поддержка проекта;
- Защита от снятия компонента с производства.



Как с нами связаться

Телефон: 8 (812) 309 58 32 (многоканальный)

Факс: 8 (812) 320-02-42

Электронная почта: org@eplast1.ru

Адрес: 198099, г. Санкт-Петербург, ул. Калинина, дом 2, корпус 4, литера А.