



Features

- Low peak clamping voltage even during severe current surges
- Ability to repeatedly protect against surge currents in excess of 10,000 amperes
- Convenient mounting and grounding to any flat surface or to Din 1 (TS-32) or DIN-3 (TS-35) rail
- Cable shields are passed through and may be either grounded or not grounded at the protector
- Vibration-proof screw-type clamp terminals
- Flame-resistant epoxy-filled housing

1800 Series – Signal and Dataline Protector

Bourns 1800 Series Signal and Dataline Protectors are designed to protect sensitive electronic circuits and components from damaging surge voltages and currents. Their extremely fast response and low clamping voltages make them particularly suitable for the protection of signal and data lines associated with computer, data communication, instrumentation, broadcasting and industrial controls. They may be used directly with EIA standard interfaces RS-232, RS-422, RS-423, RS-485 and with 20 mA and 50 mA instrumentation loops. Model 1800 Series Signal and Dataline Protectors are fast, rugged and capable of protecting against fast rising voltage transients as well as the severe current surges associated with lightning discharges.

Method of Operation

Bourns 1800 Series are heavy-duty, multi-staged protectors. A solid-state section intercepts the leading edge of the surge with sub-nanosecond response time. Within microseconds a 3-pole common chambered Gas Tube capable of handling 20,000 ampere lightning currents operates and crowbars the surge to ground. The protector remains in the crowbar state until the surge has passed and line voltages return to safe levels, then automatically restores the line to normal operation. There is no need for resetting a breaker or replacing a fuse.

Application

Protectors are generally placed at each end of a signal or data line or current loop. In the case of daisy-chain configurations (such as RS-485), protectors are placed at each node. 1820 models provide both line-to-ground and line-to-line protection and are designed to use on differential signals (such as RS-422 or RS-485) and 4-20 mA current loops. 1810 models provide line-to-ground protection for two separate circuits and are designed for use on ground referenced signals (such as RS-232) where the return wire is grounded at the protector. The 1811 and 1821 models provide the same protection modes for high frequency applications.

Related Bourns Protectors

For outdoor applications with 1/2 inch NPT ports (such as field-mounted 4-20 mA transmitters), please refer to Bourns 1669 Series Protector. In this application, the mixed use of an 1800 Series Protector at the controller and a 1669 Series Protector at the field is recommended.

Characteristics @ 25 °C

Surge Life

- >100 operations with 200 Amps..... 10 x 1000 µsec
- >10 operations with 10,000 Amps..... 8 x 20 µsec

- DC Leakage Current at Rated L/G Voltage..... >10 µAmps
- Signal/Data Attenuation at Maximum Data Rate..... 3 db with 600 Ω termination
- Operating Temperature..... -40 °C to + 60 °C
- Response Time..... 50 pico-seconds
- Wire Size..... 22-14 AWG

INTERFACE OPERATING CHARACTERISTICS			BASE MODEL NUMBER (see below for Clamp designation)	PROTECTIVE CHARACTERISTICS Peak Clamping Voltages				LOAD CURRENT (mA)	TYPICAL CAPACITANCE		SERIES RESISTANCE Each Line L/L (Input to output) (Ohms)
Peak Signal Voltage L/L (Volts)	Max. Data Rate L/G (Volts)	Rate-of-Rise (MHz)		@ 5000 Amps, 8x20 µsec Surge and Voltage Rate-of-Rise of 100 kV / µsec		@ 1000 Amps, 8x20 µsec Surge and Voltage Rate-of-Rise of 500 V / µsec			L/G (pF)	L/L (pF)	
20	10	10	1810-10-XX	50	25	42	21	220	2200	1200	10
10	10	4	1820-10-XX	25	25	21	21	220	3300	3300	10
20	10	50	1811-10-XX	60	30	52	26	350	45	45	10
10	10	50	1821-10-XX	30	30	26	26	350	65	65	10
30	15	8	1810-15-XX	70	35	56	28	180	1500	750	15
15	15	3	1820-15-XX	35	35	28	28	180	2300	2300	15
30	15	45	1811-15-XX	80	40	64	32	300	45	45	15
15	15	45	1821-15-XX	40	40	64	32	300	65	65	15
56	28	9	1810-28-XX	110	55	90	45	150	1100	600	22
28	28	4	1820-28-XX	55	55	45	45	150	1800	1800	22
56	28	40	1811-28-XX	120	60	45	45	250	45	45	22
28	28	40	1821-28-XX	60	60	45	45	250	65	65	22
100	50	10	1810-50-XX	178	89	156	89	100	500	300	51
50	50	4	1820-50-XX	89	89	45	45	100	800	800	51

1800 Series – Signal and Dataline Protector

BOURNS®

Typical Connections

Unbalanced Interface, Two Individual Circuits, Such as RS-233



Balanced or Differential Interface, Such as RS-422

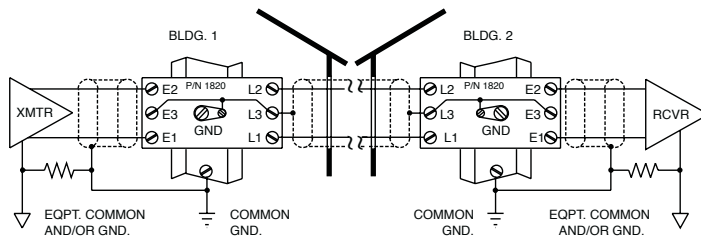

Current Loop, 4-20 mA

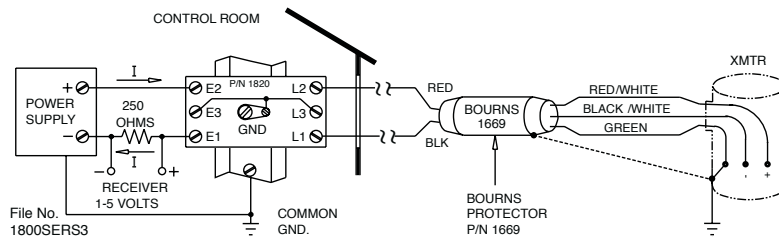

Grounding: The 8-32 mounting screw and attached clamp, and hence the DIN-1 (TS-32) or DIN-3 (TS-35) rail, serve as the protector ground. The rail (or 8-32 mounting screw if the clamp is not used) should be connected to the facility ground via an AWG #6 or larger copper wire. This wire should be as short and straight as possible. Single point grounding will provide better protection and will permit the protector to be located a distance from the equipment.

Product Dimensions

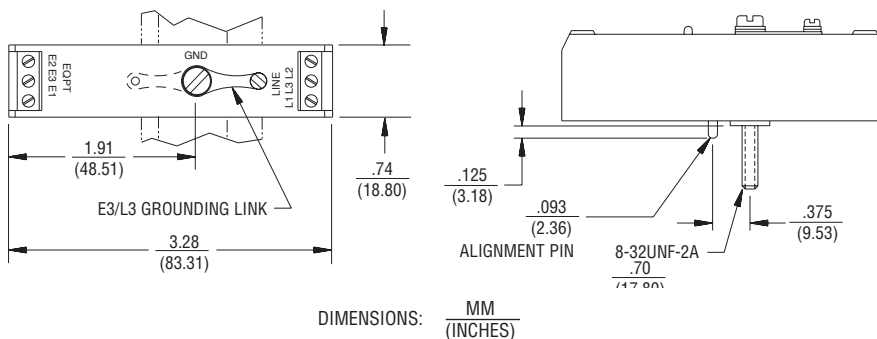

How To Order (Clamp)

Add -A1 to base model number for DIN-1 clamp.

(Example: 1810-10-A1)

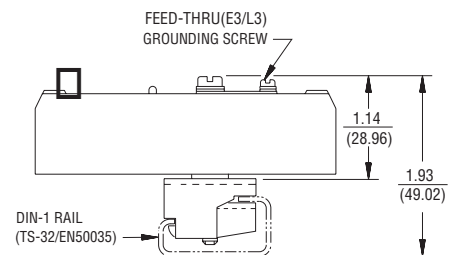

Add -A3 to base model number for DIN-3 clamp.

(Example: 1810-10-A3)

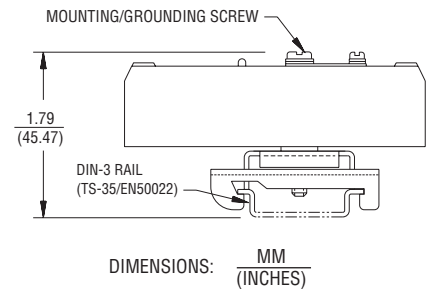

Asia-Pacific:
Tel: +886-2 2562-4117
Fax: +886-2 2562-4116

Europe:
Tel: +41-41 768 5555
Fax: +41-41 768 5510

The Americas:
Tel: +1-951 781-5500
Fax: +1-951 781-5700

www.bourns.com

REV. F 07/09

Specifications are subject to change without notice.
Customers should verify actual device performance in their specific applications



Компания «ЭлектроПласт» предлагает заключение долгосрочных отношений при поставках импортных электронных компонентов на взаимовыгодных условиях!

Наши преимущества:

- Оперативные поставки широкого спектра электронных компонентов отечественного и импортного производства напрямую от производителей и с крупнейших мировых складов;
- Поставка более 17-ти миллионов наименований электронных компонентов;
- Поставка сложных, дефицитных, либо снятых с производства позиций;
- Оперативные сроки поставки под заказ (от 5 рабочих дней);
- Экспресс доставка в любую точку России;
- Техническая поддержка проекта, помощь в подборе аналогов, поставка прототипов;
- Система менеджмента качества сертифицирована по Международному стандарту ISO 9001;
- Лицензия ФСБ на осуществление работ с использованием сведений, составляющих государственную тайну;
- Поставка специализированных компонентов (Xilinx, Altera, Analog Devices, Intersil, Interpoint, Microsemi, Aeroflex, Peregrine, Syfer, Eurofarad, Texas Instrument, Miteq, Cobham, E2V, MA-COM, Hittite, Mini-Circuits, General Dynamics и др.);

Помимо этого, одним из направлений компании «ЭлектроПласт» является направление «Источники питания». Мы предлагаем Вам помощь Конструкторского отдела:

- Подбор оптимального решения, техническое обоснование при выборе компонента;
- Подбор аналогов;
- Консультации по применению компонента;
- Поставка образцов и прототипов;
- Техническая поддержка проекта;
- Защита от снятия компонента с производства.



Как с нами связаться

Телефон: 8 (812) 309 58 32 (многоканальный)

Факс: 8 (812) 320-02-42

Электронная почта: org@eplast1.ru

Адрес: 198099, г. Санкт-Петербург, ул. Калинина, дом 2, корпус 4, литера А.