

POWER RELAY

2 POLES-2A High Insulation/wide Gap

FTR-C1 Series

■ FEATURES

- 2 Poles, 2 form C
- Contact gap: more than 0.6mm
- High surge voltage: 2500V between open contacts
5000V between coil & contact
- Complies with Telcordia (former Bellcore) 2nd level surge
- Dielectric strength: 1500VAC between open contacts
3000VAC between coil and contact
- Dimensions of large contact gap relay
 - Height: 9.3mm maximum (THT)
9.65mm maximum (SMT)
 - Length: 15mm maximum
 - Width: 7.5mm maximum
- Conforms to IEC60950/ EN60950/UL1950/CSA C 22.2
No. 950 working voltage 250V (supplementary)
- High insulation: Clearance: min 2.0mm (coil and contacts)
Creepage: min 2.5mm (coil and contacts)
- High reliability-Bifurcated contacts
- Low power consumption 280mW (latching type 140mW)
- RoHS compliant



■ PARTNUMBER INFORMATION

FTR-C1 C A 012 G - B05
 [Example] (a) (b) (c) (d) (e) (f)

(a)	Relay type	FTR-C1: FTR-C1 Series
(b)	Contact Configuration	C : Through hole type G : Surface mount type S : Surface mount type-reduced mounting area
(c)	Coil Type / Enclosure	A : Standard type B : Single coil latching type
(d)	Coil rated Voltage	012 : 3.....24 VDC Coil table at page 3
(e)	Contact Material	G : Gold plated silver palladium
(f)	Tape / reel ordering	Nil : standard packaging (tube) B05 : tape / reel package, only available for SMT type

Actual marking does not carry the type name : "FTR"

E.g.: Ordering code: FTR-C1CA012G

Actual marking: C1CA012G

FTR-C1 SERIES

■ SPECIFICATION

Item			Non-latching FTR-C1 () A	Latching FTR-C1 () B
Contact Data	Configuration		2C	
	Construction		Bifurcated	
	Material		Gold plated silver palladium	
	Resistance (Initial)		≤ 100mOhm @1A, 6VDC	
	Contact rating resistive		1A, 30VDC / 0.3A, 125VAC / 0.3A, 110VDC	
	Max. Switching Voltage		250VAC / 220VDC	
	Max. Switching Power		62.5VA / 30W	
	Max. Carry Current		2A	
	Min. Switching Load *		10mA, 10mVDC	
Life	Mechanical		2x 10 ⁶	
	Electrical		100x 10 ³ at 0.3A, 125VAC / 1A, 30VDC	
Coil Data	Rated Power		280 to 300mW	140 to 180mW
	Operate Power		158 to 162mW	158 to 162mW
	Operating temp range		-40 to +85C (no frost)	
Timing Data	Operate		≤ 6ms (at nominal voltage, no bounce)	
	Release		≤ 6ms (at nominal voltage, no bounce)	
Insulation	Resistance (Initial)		≥ 1000MOhm @500VDC	
	Dielectric strength	Open contacts	1500VAC (50/60Hz) 1min	
	Strength	Contacts to coil	3000VAC (50/60Hz) 1min	
	Surge strength	Coil to contacts	5000V, 1.2 x 10 ⁶ standard wave / 6000V, 1.2 x 50 ⁶	
	Clearance	open contacts	0.6mm	
	Clearance	adjecent contacts	1.54mm	
	Clearance	coil and contacts	2.0mm	
	Creepage	open contacts	1.54mm	
	Creepage	coil and contacts	2.0mm	
Other	Vibration Resistance	Misoperation>1us	10 to 55Hz double amplitude 3.3mm	
		Endurance	10 to 55Hz double amplitude 5mm	
	Shock	Misoperation>1us	Min. 500m/s ²	
		Endurance	Min. 1000m/s ²	
	Weight			Approx. 2 g

* Minimum switching loads mentioned above are reference values. Please perform the confirmation test with actual load before production since reference values may vary according to switching frequencies, environmental conditions and expected reliability levels.

FTR-C1 SERIES

■ COIL RATING

Standard type

Coil Code	Rated Coil Voltage (VDC)	Coil Resistance +/- 10% (Ohm)	Must Operate Voltage (V) *1	Must Release-Voltage (V) *1	Max. Coil Voltage (V)	Nominal Coil Power (mW)
003	3	32.1	2.25	0.3	4.5	230
4.5	6	72.3	3.38	0.45	6.75	
005	9	89.3	3.75	0.5	7.5	
012	12	514	9	1.2	18	
024	18	1920	18	2.4	36	300

Latching type

Coil Code	Rated Coil Voltage (VDC)	Coil Resistance +/- 10% (Ohm)	Must Operate Voltage (V) *1	Must Release-Voltage (V) *1	Max. Coil Voltage (V)	Nominal Coil Power (mW)
003	3	64.0	+2.25	2.25	4.5	140
4.5	4.5	145	+3.38	3.38	6.75	
005	5	179	+3.75	3.75	7.5	
012	12	1029	+9	9	18	
024	24	3200	+18	18	36	180

Note: All values in the table are measured at 20°C.

No contact current at 20°C

*1: Specified values are subject to pulse wave voltage

■ SAFETY STANDARDS

Type	Compliance	Contact rating
UL	UL 508	Flammability: UL 94-V0 (plastics)
	E63615	0.3A, 125 VAC (resistive) 1 A, 30VDC
CSA	C22.2 No. 14 LR 40304	0.3A, 110VDC
BSI	IEC 60950-1	

FTR-C1 SERIES

■ DIMENSIONS AND SCHEMATICS

Through hole type

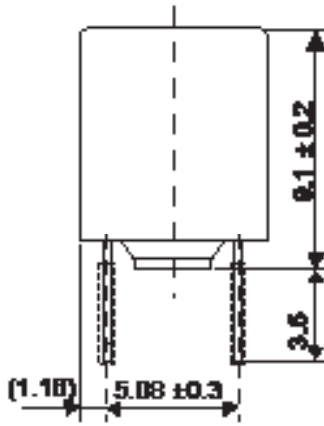
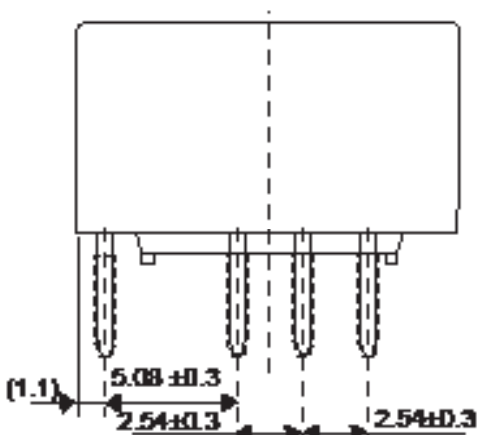
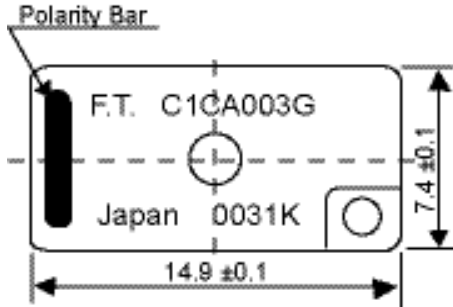

Unit: mm

■ TERMINAL DESIGNATIONS

Standard type
(Bottom view de-energized position)

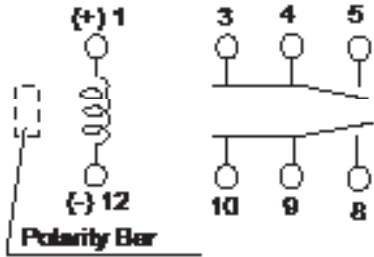

Single Coil Latching type
(Bottom view reset position)

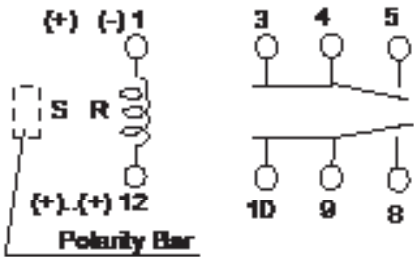

S shows the polarity of set position
R shows the polarity of reset position

■ RECOMMENDED MOUNTING PAD

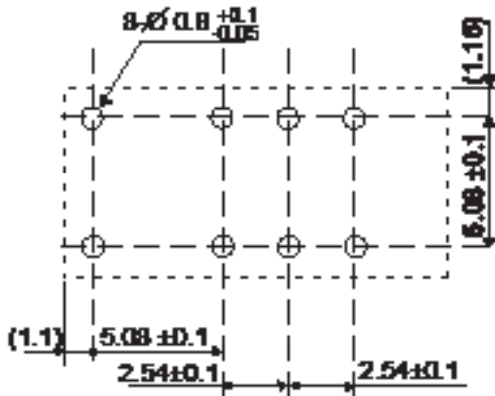

Unit: mm

FTR-C1 SERIES

■ DIMENSIONS AND SCHEMATICS

Surface mount type

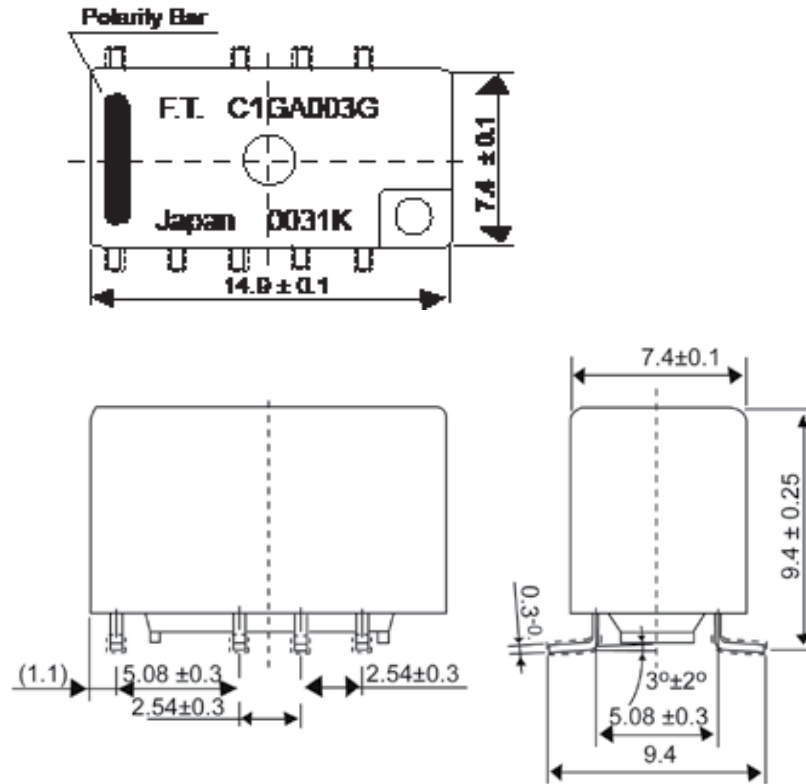

■ TERMINAL DESIGNATIONS

Standard type

(Bottom view reset position)



Single Coil Latching type

(Bottom view reset position)

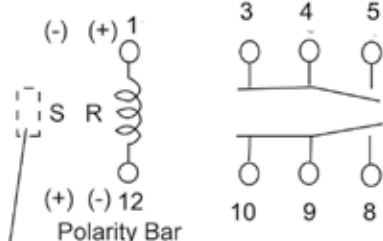

■ RECOMMENDED MOUNTING PAD

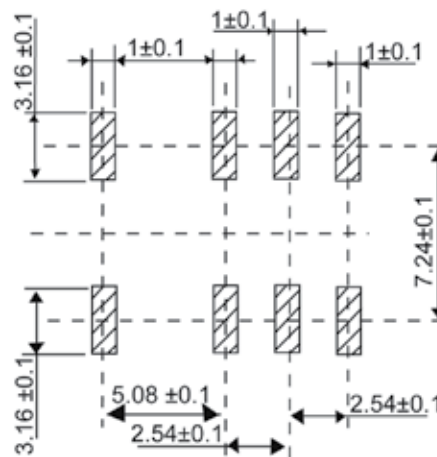

S shows the polarity of set position
R shows the polarity of reset position

Unit: mm

FTR-C1 SERIES

■ DIMENSIONS AND SCHEMATICS

Space saving type

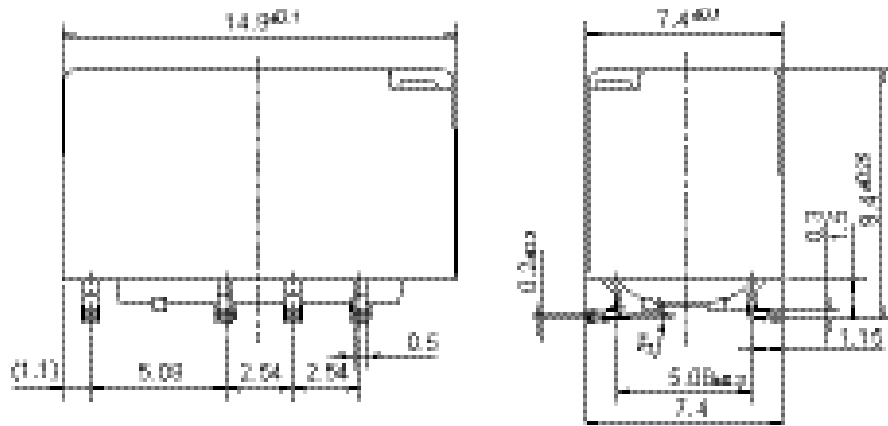

PC board mounting pad layout

Top view

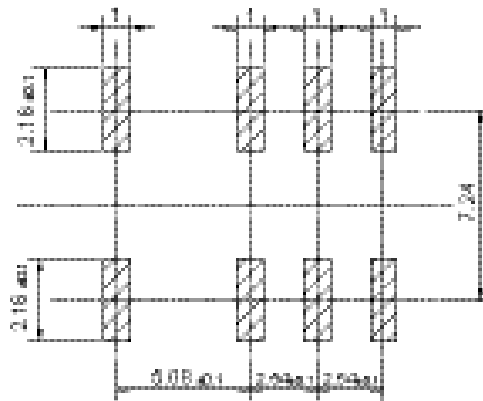

Schematics

Top view

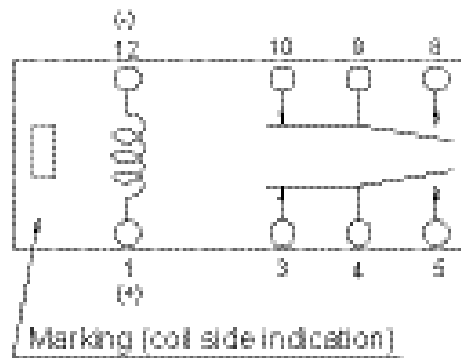

Unit: mm

FTR-C1 SERIES

■ RECOMMENDED SOLDERING CONDITIONS SMT (TEMPERATURE PROFILE, please see page 9)

Note: 1. Temperature profiles show the temperature of PC board surface.
 2. Please perform soldering test with your actual PC board before mass production, since the temperatures of PC board surfaces vary according to the size of PC board, status of parts mounting and heating method.

■ PACKAGING

Packaging method (only tape packaging is available)

- 1. Taping standards: JIS C 0806 and RC-10092B (EIAJ)
- 2. Reel type: TB2416 or TB2416
- 3. Reel type: RD24D
- 4. Quantity of 1 reel: 500 pieces

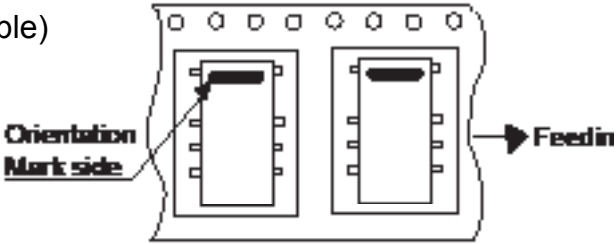

Tape Dimensions:

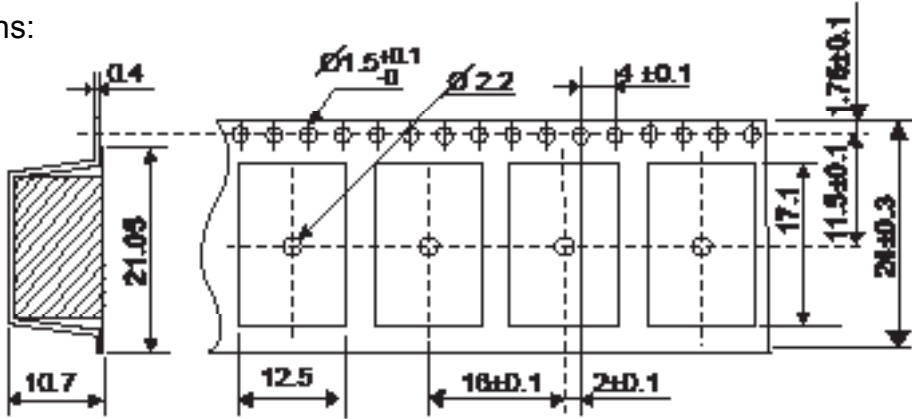

Reel Dimensions:

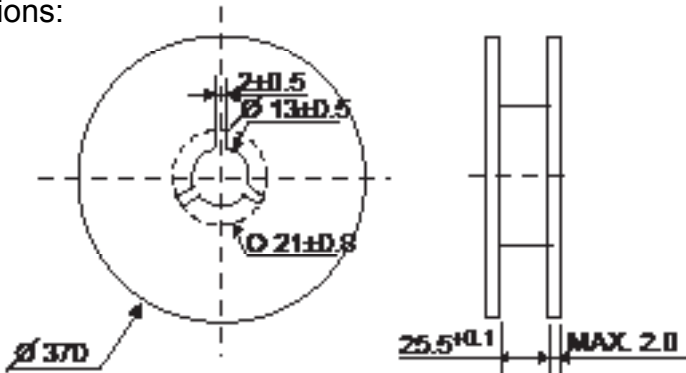

Unit: mm

RoHS Compliance and Lead Free Information

1. General Information

- All signal and power relays produced by Fujitsu Components are compliant with RoHS directive 2002/95/EC including amendments.
- Cadmium as used in electrical contacts is exempted from the RoHS directives on October 21st, 2005. (Amendment to Directive 2002/95/EC)
- All of our signal and power relays are lead-free. Please refer to Lead-Free Status Info for older date codes at: <http://www.fujitsu.com/us/downloads/MICRO/fcai/relays/lead-free-letter.pdf>
- Lead free solder plating on relay terminals is Sn-3.0Ag-0.5Cu, unless otherwise specified. This material has been verified to be compatible with PbSn assembly process.
- "LF" is marked on each outer and inner carton. (No marking on individual relays).

2. Recommended Lead Free Solder Profile

- Recommended solder Sn-3.0Ag-0.5Cu.

Flow Solder condition:

Pre-heating: maximum 120°C
Soldering: dip within 5 sec. at
260°C solder bath

Solder by Soldering Iron:

Soldering Iron
Temperature: maximum 360°C
Duration: maximum 3 sec.

We highly recommend that you confirm your actual solder conditions

3. Moisture Sensitivity

- Moisture Sensitivity Level standard is not applicable to electromechanical relays, unless otherwise indicated.

4. Tin Whiskers

- Dipped SnAgCu solder is known as presenting a low risk to tin whisker development. No considerable length whisker was found by our in house test.

FTR-C1 SERIES

Fujitsu Components International Headquarter Offices

Japan

Fujitsu Component Limited
Gotanda-Chuo Building
3-5, Higashigotanda 2-chome, Shinagawa-ku
Tokyo 141, Japan
Tel: (81-3) 5449-7010
Fax: (81-3) 5449-2626
Email: promothq@ft.ed.fujitsu.com
Web: www.fcl.fujitsu.com

North and South America

Fujitsu Components America, Inc.
250 E. Caribbean Drive
Sunnyvale, CA 94089 U.S.A.
Tel: (1-408) 745-4900
Fax: (1-408) 745-4970
Email: components@us.fujitsu.com
Web: <http://www.fujitsu.com/us/services/edevice/components/>

Europe

Fujitsu Components Europe B.V.
Diamantlaan 25
2132 WV Hoofddorp
Netherlands
Tel: (31-23) 5560910
Fax: (31-23) 5560950
Email: info@fceu.fujitsu.com
Web: emea.fujitsu.com/components/

Asia Pacific

Fujitsu Components Asia Ltd.
102E Pasir Panjang Road
#01-01 Citilink Warehouse Complex
Singapore 118529
Tel: (65) 6375-8560
Fax: (65) 6273-3021
Email: fcal@fcal.fujitsu.com
Web: <http://www.fujitsu.com/sg/services/micro/components/>

©2009 Fujitsu Components Europe B.V. All rights reserved. All trademarks or registered trademarks are the property of their respective owners.

The contents, data and information in this datasheet are provided by Fujitsu Component Ltd. as a service only to its user and only for general information purposes.

The use of the contents, data and information provided in this datasheet is at the users' own risk.

Fujitsu has assembled this datasheet with care and will endeavor to keep the contents, data and information correct, accurate, comprehensive, complete and up to date.

Fujitsu Components Europe B.V. and affiliated companies do however not accept any responsibility or liability on their behalf, nor on behalf of its employees, for any loss or damage, direct, indirect or consequential, with respect to this datasheet, its contents, data, and information and related graphics and the correctness, reliability, accuracy, comprehensiveness, usefulness, availability and completeness thereof.

Nor do Fujitsu Components Europe B.V. and affiliated companies accept on their behalf, nor on behalf of its employees, any responsibility or liability for any representation or warrant of any kind, express or implied, including warranties of any kind for merchantability or fitness for particular use, with respect to these datasheets, its contents, data, information and related graphics and the correctness, reliability, accuracy, comprehensiveness, usefulness, availability and completeness thereof. Rev. June 4, 2009



Компания «ЭлектроПласт» предлагает заключение долгосрочных отношений при поставках импортных электронных компонентов на взаимовыгодных условиях!

Наши преимущества:

- Оперативные поставки широкого спектра электронных компонентов отечественного и импортного производства напрямую от производителей и с крупнейших мировых складов;
- Поставка более 17-ти миллионов наименований электронных компонентов;
- Поставка сложных, дефицитных, либо снятых с производства позиций;
- Оперативные сроки поставки под заказ (от 5 рабочих дней);
- Экспресс доставка в любую точку России;
- Техническая поддержка проекта, помощь в подборе аналогов, поставка прототипов;
- Система менеджмента качества сертифицирована по Международному стандарту ISO 9001;
- Лицензия ФСБ на осуществление работ с использованием сведений, составляющих государственную тайну;
- Поставка специализированных компонентов (Xilinx, Altera, Analog Devices, Intersil, Interpoint, Microsemi, Aeroflex, Peregrine, Syfer, Eurofarad, Texas Instrument, Miteq, Cobham, E2V, MA-COM, Hittite, Mini-Circuits, General Dynamics и др.);

Помимо этого, одним из направлений компании «ЭлектроПласт» является направление «Источники питания». Мы предлагаем Вам помощь Конструкторского отдела:

- Подбор оптимального решения, техническое обоснование при выборе компонента;
- Подбор аналогов;
- Консультации по применению компонента;
- Поставка образцов и прототипов;
- Техническая поддержка проекта;
- Защита от снятия компонента с производства.



Как с нами связаться

Телефон: 8 (812) 309 58 32 (многоканальный)

Факс: 8 (812) 320-02-42

Электронная почта: org@eplast1.ru

Адрес: 198099, г. Санкт-Петербург, ул. Калинина, дом 2, корпус 4, литера А.