

heavy | mate[®]

Heavy Duty Connectors



Note from the CEO



Ladies and Gentlemen,

For over 75 years Amphenol has enjoyed success as the interconnection technology provider of choice to industry-leading companies around the world. One of our key strategic areas of focus has been and is the Industrial market. Our organization works with leading manufacturers across a wide range of applications - including Energy Generation & Distribution, Transportation, Heavy Equipment, Factory Automation, Wireless Outdoor, ChipCard Readers - enabling smarter, faster and better technologies to connect products to customer solutions.

The Industrial market footprint of Amphenol covers over facilities in more than 12 different European countries and more than 30 countries worldwide. Our successful expansion into new regions as well as new industrial applications is a direct reflection of our agile, entrepreneurial management team and our unwavering commitment to execute Amphenol's strategies for the benefit of our customers, shareholders and employees.

Thank you for partnering with Amphenol. Our entire organization is at your service.

A handwritten signature in black ink, appearing to read 'R. Adam Norwitt'. The signature is fluid and stylized, with a large initial 'R'.

R. Adam Norwitt
President and CEO, Amphenol Corporation

Make use of the best

Use our global resources

“Think global, act local!” Independently from where you are in Europe, we offer you our global expertise and great variety of products and technologies. And in comfort with your personal contact. Our numerous European offices are your access to our global resources.

● OUR OFFICES IN EUROPE AND WORLDWIDE

| | | | |
|----------------|--------|-----------|--------------|
| FRANCE | CHINA | AUSTRALIA | SOUTH AFRICA |
| GERMANY | KOREA | MEXICO | INDIA |
| UNITED KINGDOM | TAIWAN | USA | ITALY |





SECURITY, RELIABILITY AND COMFORTABLE SERVICE FROM ONE SOURCE.

More time for important things: benefit from our service and diversity

Enjoy security, reliability and comfortable service from one source. INDUSTRIAL@AMPHENOL offers one of the most individual and most diversified service programmes in the market – exclusively for industrial customers. Access all possibilities of the Amphenol group through your personal expert adviser.



WIDE PRODUCT RANGE

Take advantage of a choice of Amphenol products. Our broad product portfolio offers individual solutions from more than 85 member companies in the global Amphenol group.



EXCLUSIVENESS AND FLEXIBILITY

One face to the customer: every inquiry is handled on an individual service level by your personal key account service partner. This ensures maximum transparency and best-in-class flexibility in the whole process.



QUALITY

Interconnect systems need reliability, speed and flawless data transmission. We continuously test and guarantee the required standard in our products – and also in our personal services.



INDIVIDUAL SOLUTIONS

Your project requires an individual solution that is not available off-the-shelf? As your think tank and discussion partner we provide engineering support and solution-oriented development for your tailor-made Amphenol product.



SPEED AND AVAILABILITY

Smart and intelligent processes are the secret behind our service programme. Flexible planning and distribution, perfect logistics and highest availability are our key factors for best customer service.



GLOBAL KEY ACCOUNT SERVICE

Our key account service is your individual entrance to global know-how, products and services. More than 85 Amphenol companies around the world offer an extensive range of technologies and products. We offer access to our worldwide resources through one individual contact person.

heavy|mate[®] is a Modular Metal Connector Line

What is heavy|mate[®] ?

heavy|mate[®] is a modular connector line, consisting of:

- Hoods & Housings
- Inserts
- Contacts

Why heavy|mate[®] ?

- Connections in harsh industrial environment
- Robust design necessary
- High number of poles or different kinds of signals transmitted
- Very good EMC protection required
- Power and signal transmission outdoor
- Very save locking system required

for Applications in Industrial Environments.



Major product features

- Hybrid interconnections
- Good costs
- Voltage up to 1000V
- VDE, UL, CSA approvals
- Vibration proof
- High current
- Signal transmission
- High pole sizes
- IP65 to IP68
- Corrosion resistance
- Robust

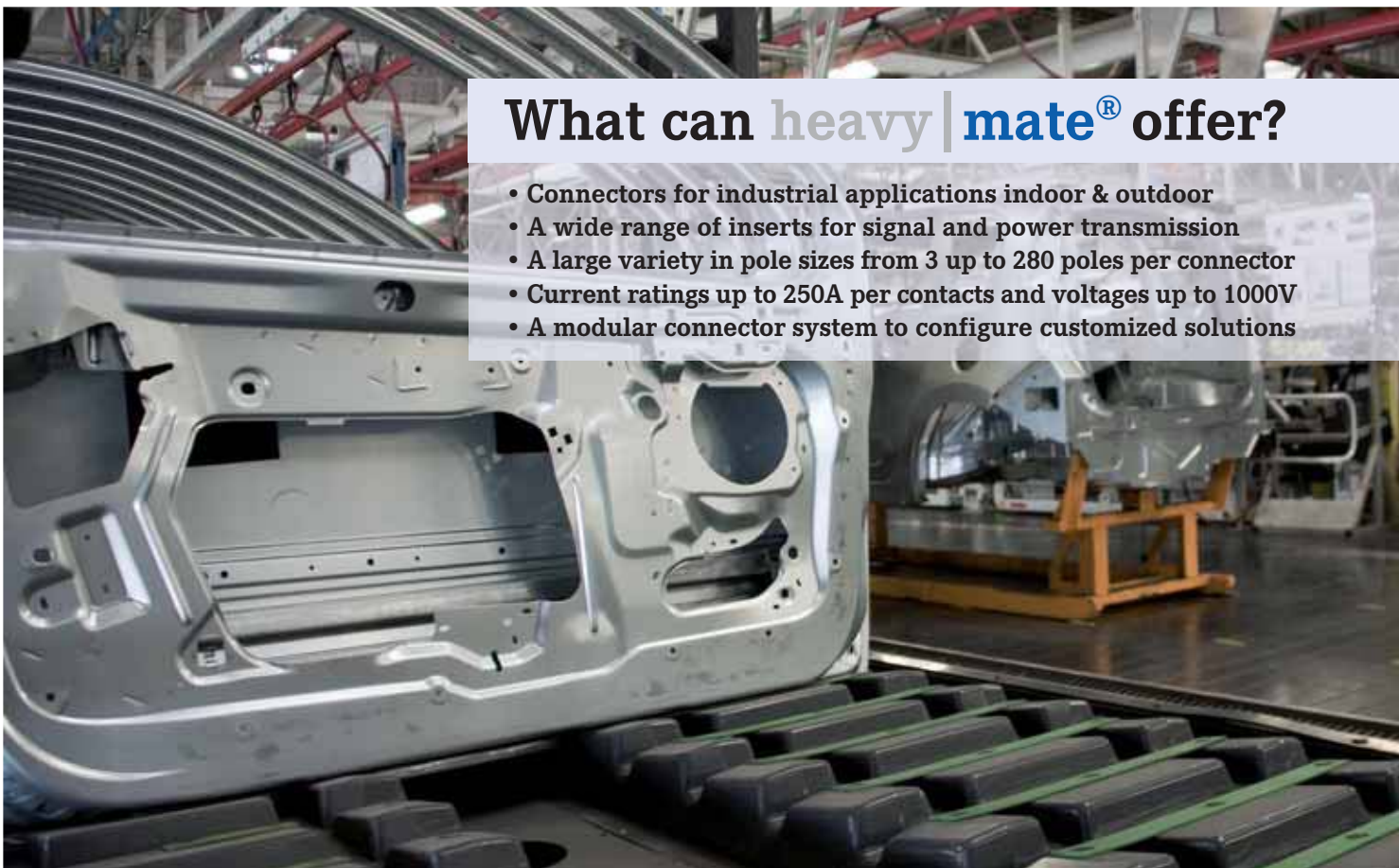

What can heavy | **mate**[®] offer?

- Connectors for industrial applications indoor & outdoor
- A wide range of inserts for signal and power transmission
- A large variety in pole sizes from 3 up to 280 poles per connector
- Current ratings up to 250A per contacts and voltages up to 1000V
- A modular connector system to configure customized solutions

How to select a solution with series heavy | mate®.

Theory

- Select an insert that meets your requirements.
- Choose the related contacts if not included in inserts.
- Choose related housings.
- Choose related cable gland.
- If you are interested in a cable assembly, please ask us.

Practice 1

Requirements

- 250V
- 5A
- 60 contacts
- Termination: crimp

Solution

- Check: Make a pre-selection on the overview page of the series, s. p. 10/11
Possible series: heavy | mate® D, DD and M
- Check: Details on the overview pages of the sub-series, see pages 22, 38, 114
All 3 variants are possible; Selection heavy | mate® D
- Check: Contact inserts on the detail page of the sub-series
Selection: C146 10A064 000 2
- Check: Contacts on the same double page
Selection: VN01 016 0002 1
- Check: Housings via crosslink at contact inserts
Selection: C146 21R024 600 8
- Check: Gland bushing via crosslink at housings
Selection: VN16 320 0126X



Practice 2

Requirements

- 3 x 400V; 50A; 6mm² wire gauge
- 8 x 250V; 8A; 1.5mm² wire gauge
- 5 x 400V; 15A; 4mm² wire gauge

Solution

- **Check:** Make a pre-selection on the overview page of the series, see pages 10/11
Possible series: heavy | **mate**[®] M
- **Check:** How 16 contacts can be realized, see modules overview on page 118
Possible selection: a) 1 x 20 contacts
b) 2 x 10 contacts
c) 1 x 10 contacts + 1 x 5 contacts
d) 1 x 3 contacts + 1 x 5 contacts + 1 x 10 contacts
- **Check:** Technical parameters / solution, see detail pages of the modules on page 126
Possible selection: a) not possible due to voltage
b) not possible due to voltage
c) not possible due to current
d) POSSIBLE
- **Check:** Choose matching contact, see detail page of the modules on page 126
Possible selection: a) C146 A03 001 E8 - VN01 036 0002 1C
b) C146 A0 001 E8 - VN01 025 0033 1C
c) C146 A10 001 E8 - VN01 016 0027 1XC
- **Check:** Choose matching frame, see frames on page 124
Solution: C146 P10 001 G8
- **Check:** Choose matching housing, see housings on page 162
Solution: C146 21R010 600 8

Make your selection out of the heavy | mate® series!

| Series Characteristic | A page 14 | D page 22 | DD page 38 | E page 44 | EE page 62 | E / FE / KO page 68 | F page 74 |
|----------------------------|--------------|--------------|---------------|--------------------|---------------|------------------------|--------------|
| Voltage | | | | | | | |
| 250V | ● | ● | ● | ● | ● | ● | ● |
| 400V | ● | | | ● | ● | ● | ● |
| 500V | | | | ● | ● | | ● |
| 690V | | | | | | | ● |
| 830V | | | | | | | ● |
| 1000V | | | | | | | |
| Current | | | | | | | |
| 10A | ● | ● | ● | ● | ● | ● | ● |
| 16A | ● | | | ● | ● | | ● |
| 35A | | | | | | | ● |
| 80A | | | | | | | ● |
| 100A | | | | | | | |
| 200A | | | | | | | |
| Numbers of contacts | | | | Modules for | | | |
| | 3 | 7 | 24 | 6 | 10 | 6 | 3 |
| | 4 | 8 | 42 | 10 | 18 | 10 | 6 |
| | 10 | 15 | 72 | 16 | 32 | 16 | 8 |
| | 16 | 25 | 108 | 24 | 46 | 24 | 12 |
| | | 40 | | | | | 17 |
| | | 64 | | | | | 20 |
| Termination | | | | | | | |
| Crimp | | ● | ● | ● | ● | | ● |
| Screw | ● | | | ● | | ● | |
| Tension spring | | | | ● | | | |

Cross reference list see www.amphenol.de/xref/

| HSE page 94 | HvE page 98 | K page 108 | M page 114 | Q page 156 | Housings page 162 | Accessories page 223 | Series Characteristic |
|--------------------|----------------------------|--------------------------|-----------------------------------|----------------------------|----------------------|-------------------------|--------------------------|
| Voltage | | | | | | | |
| ● | ● | ● | ● | ● | | | 250V |
| ● | ● | ● | ● | ● | | | 400V |
| | ● | ● | ● | ● | | | 500V |
| | ● | ● | ● | | | | 690V |
| | | ● | ● | | | | 830V |
| | | | ● | | | | 1000V |
| Current | | | | | | | |
| ● | ● | ● | ● | ● | | | 10A |
| ● | ● | ● | ● | ● | | | 16A |
| ● | | ● | ● | | | | 35A |
| | | ● | ● | | | | 80A |
| | | | ● | | | | 100A |
| | | | ● | | | | 200A |
| Modules for | | | | Numbers of contacts | | | |
| 6 | 3+2 6+2 10+2 16+2 | 4 / 0 4 / 2 6 / 36 | 1 2 3 4 5 10 20 | 5 7 | | | |
| Termination | | | | | | | |
| | | ● | ● | ● | | | Crimp |
| ● | ● | ● | | | | | Screw |
| | | | | | | | Tension spring |

The highlights of the series heavy|mate®.

Contact technology

- Turned contacts, which correspond to the market standard.
- Turned female contacts of copper for higher current-carrying capacity – specifically for the modular system heavy|mate® M.
- Radsok contact technology: These are laminated contacts with very low transition resistance, suitable for high current applications.
- Stamped contacts with high performance for semi-automatic processing at great cost savings.
- Selectively coated gold plating stamped contacts offer great savings.



Housings

Surface coatings available in two versions: Standard or High-End with a salt mist resistance up to 500 hours.

Flexible cable entry in different positions – possible on request.

Tightness classes in IP65, IP67 or IP68!

Robust metal levers in 1 and 2 locking-lever-system.

Quality EMC solutions.



Modular system

With the new series heavy|mate® F Amphenol offers a new modular system that is compatible with the market leader. With the series heavy|mate® M Amphenol offers a system with many benefits:

- More module slots in the connector.
- Large selection of contact-safe male contacts
- Stamped contacts and the Radsok contact technology
- Great cost savings potential





The background of the entire page is a high-contrast, industrial scene. It features a dark, metallic surface, possibly a machine part, with a shower of bright orange and yellow sparks falling from the top left. The scene is lit with a mix of blue and white light, creating a bokeh effect of out-of-focus light spots. In the upper center, there is a close-up of a mechanical component with two circular gauges and several hexagonal bolts. A blue metal rod or handle is visible, extending from the top left towards the center. The overall atmosphere is one of intense industrial activity and precision.

heavy | mate[®] A

- Rated voltage 250 / 400 V
- Rated current 14 A ... 18 A
- Termination: screw
- Number of contacts: 3, 4, 10, 16, 32



| Approvals, Testhouse | Characteristics | Approval-Number |
|--|-------------------------|-----------------|
| SEV  | 250 V, 10 A | |
| UL  | 600 V, 14 A | E 63093 |
| CSA  | 600 V, 10 A; 16 A; 20 A | LR 700721 |

In general approvals refer to representative versions of the connector series. Extent and specification of tests upon request.

General information

- For series heavy|mate® A connectors may be engaged or disengaged when live but without electrical load. If these connectors are used as plug and socket device, the load shall be reduced to 10 % of the rated current.

- Low and high profile housing for heavy|mate® A series inserts for 10 and 16 contacts.



No standard for this series, but:

- Interchangeable with other makes
 - contact insert to contact insert
 - contact insert to housing 10, 16 contacts

Housings are designed according to DIN EN 175 301 - 801

First-to-mate last-to-break protective ground contact



Range of housings

Size A3/4



Size A10



Size A16



heavy|mate® A Characteristics contact inserts

| General Characteristics | Standard | Value | | | |
|---|-----------------|----------------------------|--------|------------|--------|
| Number of contacts | | 3/4 + ⊕ | 10 + ⊕ | 16 + ⊕ | 32 + ⊕ |
| Termination technique | | screw | | | |
| Wire gauge | | 0.25 - 2.5 mm ² | | | |
| Flammability | UL 94 | V-0 | | | |
| Electrical Characteristics | | | | | |
| Rated voltage | IEC 60664-1 | 400 V | 250 V | | |
| Pollution degree | IEC 60664-1 | 3 | | | |
| Installation (overvoltage) category | IEC 60664-1 | III | | | |
| Material group | IEC 60664-1 | III b | | | |
| Rated impulse withstand voltage | IEC 60664-1 | 4 KV | | | |
| Current carrying capacity | IEC 60512-5-2 | see derating curves | | | |
| Rated current T _{amp} = 40 °C | | 18 A | 16 A | 14 A | 14 A |
| Contact resistance | IEC 60512-2-1 | ≤ 5 m Ω | | | |
| Insulation resistance | IEC 60512-3-1 | ≥ 10 ¹⁰ Ω | | | |
| Climatical Characteristics | | | | | |
| Climatic category | IEC 60068-1 | 40 / 100 / 21 | | | |
| Upper temperature | IEC 60512-11-9 | + 100 °C | | | |
| Lower temperature | IEC 60512-11-10 | - 40 °C | | | |
| Mechanical Characteristics | | | | | |
| IP-degree of protection pin insert ¹⁾ | IEC 60529 | unmated IP00 | | mated IP20 | |
| IP-degree of protection socket insert ¹⁾ | IEC 60529 | unmated IP20 | | mated IP20 | |
| Weight pin insert | | 13 g | 48 g | 68 g | 136 g |
| Weight socket insert | | 13 g | 52 g | 73 g | 146 g |
| Mechanical operation | IEC 60512-9-1 | ≥ 500 mating cycles | | | |
| Materials | | | | | |
| Insert | | PA | PBT | PBT | PBT |
| Contacts | | Cu Zn (brass) | | | |
| Contact plating | | Ag (silver) | | | |

| Description | Part Number | Drawing | Figure |
|--|-------------------|--|---|
| Contact insert 3 + ⊕ | | | |
| Male insert for screw termination | C146 10A003 002 4 |  |  |
| Female insert for screw termination | C146 10B003 002 4 |  |  |

Pin layout



| Description | Part Number | Drawing | Figure |
|--|-------------------|--|---|
| Contact insert 4 + ⊕ | | | |
| Male insert for screw termination | C146 10A004 002 4 |  |  |
| Female insert for screw termination | C146 10B004 002 4 |  |  |

Pin layout



Derating curves



| Curve | Wire gauge |
|-------|---------------------|
| a | 1.5 mm ² |
| b | 2.5 mm ² |

| Description | Part Number | Drawing | Figure |
|--|-------------------|---------|--------|
| Contact insert 10 + ⊕ | | | |
| Male insert for screw termination | C146 10A010 002 4 | | |
| Male insert with wire protection for screw termination | C146 10A010 102 4 | | |
| Female insert for screw termination | C146 10B010 002 4 | | |
| Female insert with wire protection for screw termination | C146 10B010 102 4 | | |

| Pin layout | | Assembly instruction | |
|-------------|---------------|------------------------|--|
| Male insert | Female insert | Panel cut out (insert) | |
| | | | |



| Description | Part Number | Drawing | Figure |
|--|-------------------|---------|--------|
| Contact insert 16 + ⊕ | | | |
| Male insert for screw termination | C146 10A016 002 4 | | |
| Male insert with wire protection for screw termination | C146 10A016 102 4 | | |
| Female insert for screw termination | C146 10B016 002 4 | | |
| Female insert with wire protection for screw termination | C146 10B016 102 4 | | |

Pin layout

Assembly instruction

Male insert

Female insert

Panel cut out (insert)

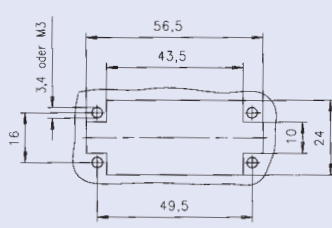

Derating curves



| Curve | Wire gauge |
|-------|---------------------|
| a | 1.5 mm ² |
| b | 2.5 mm ² |

| Description | Part Number | Drawing | Figure |
|--|--|---------|--------|
| Contact insert 32 + ⊕ | | | |
| Male insert for screw termination | C146 10A016 002 4 (1 - 16) + C146 10A016 004 4 (17 - 32) | | |
| Male insert with wire protection for screw termination | C146 10A016 102 4 (1 - 16) + C146 10A016 104 4 (17 - 32) | | |
| Female insert for screw termination | C146 10B016 002 4 (1 - 16) + C146 10B016 004 4 (17 - 32) | | |
| Female insert with wire protection for screw termination | C146 10B016 102 4 (1 - 16) + C146 10B016 104 4 (17 - 32) | | |

Pin layout

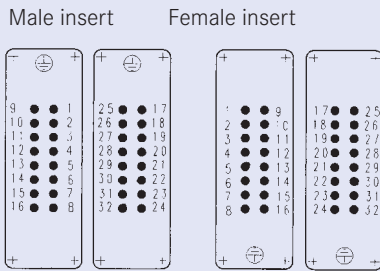

Assembly instruction

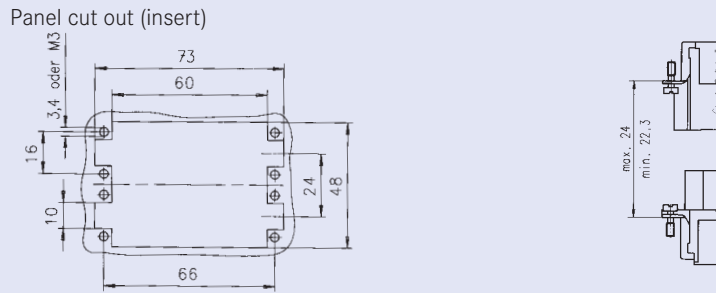

Derating curves

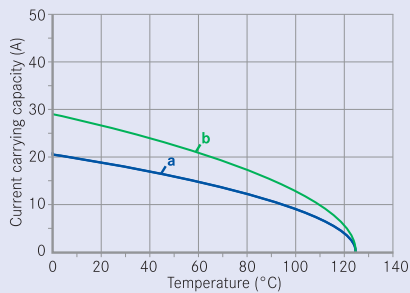

| Curve | Wire gauge |
|-------|---------------------|
| a | 1.5 mm ² |
| b | 2.5 mm ² |



heavy | mate[®] D

- Rated voltage 250 V
- Rated current 10 A ... 16 A
- Termination: crimp
- Number of contacts: 7, 15, 25, 40, 50, 64, 128



| Approvals, Testhouse | Characteristics | Approval-Number |
|--|---|-----------------|
| SEV  | 250 V, 10 A | |
| UL  | 600 V, 14 A 600 V, 15 A (high current) | E 63093 |
| CSA  | 600 V, 10 A | 48932 |

In general approvals refer to representative versions of the connector series. Extent and specification of tests upon request.

General information

- Contact inserts without crimp contacts, crimping tools see separate catalogue „Tools“.
- Contacts must be ordered separately, processing instructions see catalogue „Tools“.
- We recommend using the high profile housings / hoods for the heavy|mate® D inserts.
- Connectors series heavy|mate® D may be engaged or disengaged when live but without electrical load.
If these connectors are mated or unmated under load, the load shall be reduced to 10 % of the rated current.
- For contact inserts for turned contacts, guide pins and guide socket are recommended (see page 226).
- By using contact inserts with two PE-connections without hoods, it is necessary to connect the facing of each PE-connection.
- If connectors are mounted in non conductive housings both protective earthing terminals shall be mounted.



Standardised connectors according to DIN EN 175 301 - 801 (DIN 43652)

Interchangeable with all other products which are according to the standard.

- a) Contact insert to contact insert 15, 25, 40, 64 way.
- b) Contact insert to housing 15, 25, 40, 64 way.

High protection against mismatching

- Female inserts with funnel shaped contact entry avoids mismatching with stamped contacts.



First-to-mate last-to-break protective ground contact



Contact inserts for stamped contacts and for turned contacts



Range of housings

Size A3/4



Size A10



Size A16



Size E16

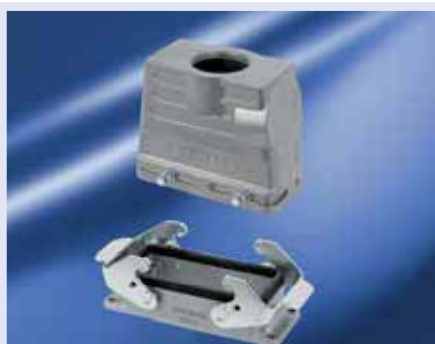

Size E24



Size E48



Modified contact arrangement for rated voltages of 400 V

(15) → 7 + ⊕



Female insert Male insert

(25) → 11 + ⊕

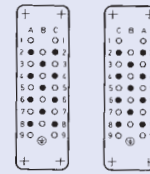

Female insert Male insert

(40) → 20 + ⊕

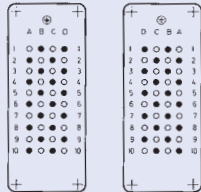

Female insert Male insert

(64) → 32 + ⊕

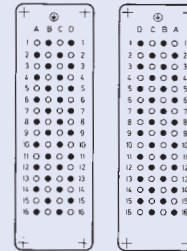

Female insert Male insert

- full load contact
- unoccupied

Removal of contacts, front releas

stamped male contacts
all turned contacts



stamped female contacts



heavy|mate® D Characteristics contact inserts

| General Characteristics | Standard | Value | | | | | | | |
|--|--------------------------------|--|---------------------|------|------|------------|------|-------------|--|
| Number of contacts | | 7 | 15 | 25 | 40 | 50 2x25 | 64 | 128 2x64 | |
| Contact arrangement | DIN EN 175 301-801 (DIN 43652) | | • | • | • | | • | | |
| Termination technique | | crimp, wire wrap | | | | | | | |
| Max. wire diameter | | 4.1 mm | | | | | | | |
| Flammability | UL 94 | V-0 | | | | | | | |
| Electrical Characteristics | | | | | | | | | |
| Rated voltage ¹⁾ | IEC 60664-1 | 250 V~ (400 V~ ²⁾) (600 V UL / CSA ³⁾) | | | | | | | |
| Pollution degree | IEC 60664-1 | 3 | | | | | | | |
| Installation (overvoltage) category | IEC 60664-1 | III | | | | | | | |
| Material group | IEC 60664-1 | III b | | | | | | | |
| Rated impulse withstand voltage | IEC 60664-1 | 4 kV | | | | | | | |
| Rated current | IEC 60512-5-2 | see derating curves | | | | | | | |
| Rated current T _{amp} = 40 °C | | 16 A | 12 A | 12 A | 10 A | 10 A | 10 A | 10 A | |
| Insulation resistance | IEC 60512-3-1 | ≥ 10 ¹⁰ Ω | | | | | | | |
| Climatical Characteristics | | | | | | | | | |
| Climatic category | IEC 60068-1 | 40/125/21 | | | | | | | |
| Upper temperature | IEC 60512-11-9 | + 125°C | | | | | | | |
| Lower temperature | IEC 60512-11-10 | - 40°C | | | | | | | |
| Mechanical Characteristics | | | | | | | | | |
| IP-degree of protection pin insert | IEC 60529 | unmated IP00 | | | | mated IP20 | | | |
| IP-degree of protection socket insert | IEC 60529 | unmated IP20 | | | | mated IP20 | | | |
| Weight pin insert | | 8 g | 28 g | 34 g | 53 g | 68 g | 65 g | 130 g | |
| Weight socket insert | | 8 g | 30 g | 38 g | 64 g | 76 g | 82 g | 164 g | |
| Mechanical operation | IEC 60512-9-1 | ≥ 500 mating cycles | | | | | | | |
| Materials | | | | | | | | | |
| Insert | IEC 60664-1 | PBTP | PC GV ⁴⁾ | | | | | | |
| Colour insert | IEC 60664-1 | grey | | | | | | | |

| Description | Part Number | Drawing | Figure |
|--|-------------------|---------|--------|
| Contact insert 7 + ⊕, 42 V~ in metal housings/250 V in thermoplastic housings (Please order contacts separately, see page 34) | | | |
| Male insert for stamped crimp contacts | C146 10A007 000 2 | | |
| Male insert for turned crimp contacts | C146 10A007 500 2 | | |
| Female insert for stamped crimp contacts | C146 10B007 000 2 | | |
| Female insert for turned crimp contacts | C146 10B007 500 2 | | |

Pin layout



| Description | Part Number | Drawing | Figure |
|--|-------------------|---------|--------|
| Contact insert 8, 42 V~ in metal housings/250 V in thermoplastic housings (Please order contacts separately, see page 34) | | | |
| Male insert for stamped crimp contacts | C146 10A008 000 2 | | |
| Male insert for turned crimp contacts | C146 10A008 500 2 | | |
| Female insert for stamped crimp contacts | C146 10B008 000 2 | | |
| Female insert for turned crimp contacts | C146 10B008 500 2 | | |

Pin layout (Note: For use up to 42 V~, the PE contact can be used as regular contact.)



Derating curves



| Curve | Wire gauge |
|-------|--|
| a | 0.5 mm ² |
| b | 1.5 mm ² & 2.5 mm ² |
| c | 1.5 mm ² - 2.5 mm ² (High current) |



| Curve | Wire gauge |
|-------|---------------------|
| a | 0.5 mm ² |
| b | 1.5 mm ² |
| c | 2.5 mm ² |

Description | **Part Number** | **Drawing** | **Figure**

Contact insert 15 + ⊕ (Please order contacts separately, see page 34)

| | | | |
|---|-------------------|--|--|
| Male insert for stamped crimp contacts | C146 10A015 000 2 | | |
| Male insert for turned crimp contacts | C146 10A015 500 2 | | |
| Female insert for stamped crimp contacts | C146 10B015 000 2 | | |
| Female insert for turned crimp contacts | C146 10B015 500 2 | | |

Contact insert 15 + ⊕, 2 x PE-termination (Please order contacts separately, see page 34)

| | | | |
|---|-------------------|--|--|
| Male insert for stamped crimp contacts | C146 10A015 060 2 | | |
| Female insert for stamped crimp contacts | C146 10B015 060 2 | | |

Pin layout | **Assembly instruction**

| | | | |
|-------------|---------------|------------------------|--|
| Male insert | Female insert | Panel cut out (insert) | |
| | | | |

Derating curves



| Description | Part Number | Drawing | Figure |
|--|-------------------|---------|--------|
| Contact insert 25 + ⊕ (Please order contacts separately, see page 34) | | | |
| Male insert for stamped crimp contacts | C146 10A025 000 2 | | |
| Male insert for turned crimp contacts | C146 10A025 500 2 | | |
| Female insert for stamped crimp contacts | C146 10B025 000 2 | | |
| Female insert for turned crimp contacts | C146 10B025 500 2 | | |

| | | | |
|---|-------------------|--|--|
| Contact insert 25 + ⊕ , 2 x PE-termination (Please order contacts separately, see page 34) | | | |
| Male insert for stamped crimp contacts | C146 10A025 060 2 | | |
| Female insert for stamped crimp contacts | C146 10B025 060 2 | | |

| Pin layout | | Assembly instruction | |
|-------------|---------------|------------------------|--|
| Male insert | Female insert | Panel cut out (insert) | |
| | | | |



Description | **Part Number** | **Drawing** | **Figure**

Contact insert 40 + ⊕ (Please order contacts separately, see page 34)

| | | | |
|---|-------------------|--|--|
| Male insert for stamped crimp contacts | C146 10A040 000 2 | | |
| Male insert for turned crimp contacts | C146 10A040 500 2 | | |
| Female insert for stamped crimp contacts | C146 10B040 000 2 | | |
| Female insert for turned crimp contacts | C146 10B040 500 2 | | |

Contact insert 40 + ⊕, 2 x PE-termination (Please order contacts separately, see page 34)

| | | | |
|---|-------------------|--|--|
| Male insert for stamped crimp contacts | C146 10A040 060 2 | | |
| Female insert for stamped crimp contacts | C146 10B040 060 2 | | |

Pin layout | **Assembly instruction**

| | | | |
|-------------|---------------|------------------------|--|
| Male insert | Female insert | Panel cut out (insert) | |
| | | | |

Derating curves

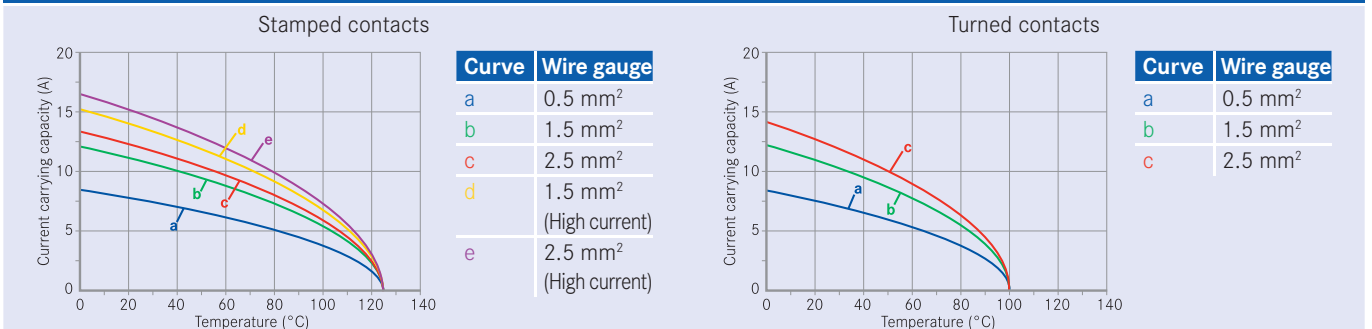

| Description | Part Number | Drawing | Figure |
|--|---|---------|--------|
| Contact insert 50 + ⊕ (Please order contacts separately, see page 34) | | | |
| Male insert for stamped crimp contacts | C146 10A025 000 2 + C146 10A025 005 2 | | |
| Male insert for turned crimp contacts | C146 10A025 500 2 + C146 10A025 505 2 | | |
| Female insert for stamped crimp contacts | C146 10B025 000 2 + C146 10B025 005 2 | | |
| Female insert for turned crimp contacts | C146 10B025 500 2 + C146 10B025 505 2 | | |

| Pin layout | Assembly instruction |
|---------------------------------------|-------------------------------|
| <p>Male insert Female insert</p> | <p>Panel cut out (insert)</p> |

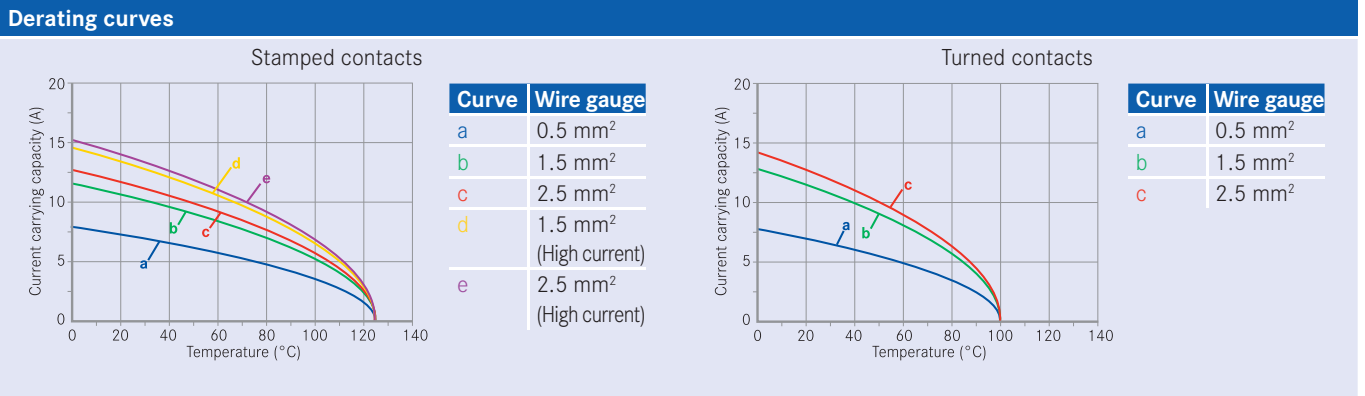

Description | **Part Number** | **Drawing** | **Figure**

Contact insert 64 + ⊕ (Please order contacts separately, see page 34)

| | | | |
|---|-------------------|--|--|
| Male insert for stamped crimp contacts | C146 10A064 000 2 | | |
| Male insert for turned crimp contacts | C146 10A064 500 2 | | |
| Female insert for stamped crimp contacts | C146 10B064 000 2 | | |
| Female insert for turned crimp contacts | C146 10B064 500 2 | | |

Contact insert 64 + ⊕, 2 x PE-termination (Please order contacts separately, see page 34)

| | | | |
|---|-------------------|--|--|
| Male insert for stamped crimp contacts | C146 10A064 060 2 | | |
| Female insert for stamped crimp contacts | C146 10B064 060 2 | | |

Pin layout | **Assembly instruction**

| | | | |
|-------------|---------------|------------------------|--|
| Male insert | Female insert | Panel cut out (insert) | |
| | | | |

Derating curves



Large range of wire gauges

.N01 016 0003 (1)



.N01 016 0002 (1)



.N01 016 0005 (1)



Gas-tight (coldwelding)

0.14

0.25

0.5



0.5

1.0

1.5



1.5

2.5



Stamped crimp contacts with insulation crimp, to absorb mechanical stress from the crimped connection

Insulation grip



Mechanical retention spring stop on female and male contact

Female contact



Male contact

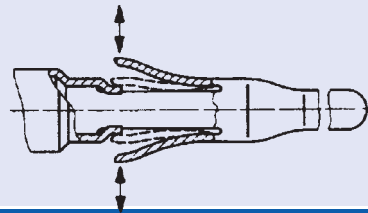

High current carrying capacity

Example single contact



Curve a: 2.5 mm² Standard contact. wire gauge



Curve a: 2.5 mm² High current contact, wire gauge

| Stamped crimp contacts | | |
|-----------------------------------|-----------------|-------------------------|
| Electrical Characteristics | | |
| Contact resistance | IEC 60512-2-1 | ≤ 5 m Ω |
| Climatical Characteristics | | |
| Upper temperature | IEC 60512-11-9 | + 125 °C |
| Lower temperature | IEC 60512-11-10 | - 40 °C |
| Mechanical Characteristics | | |
| Mechanical operation | IEC 60512-9-1 | ≥ 500 mating cycles |
| Materials | | |
| Male contact | | Cu Zn (brass) |
| Female contact | | Cu Sn (tin bronze) |
| Contact plating | | Ag (silver) / Au (gold) |
| Turned crimp contacts | | |
| Electrical Characteristics | | |
| Contact resistance | IEC 60512-2-1 | ≤ 5 m Ω |
| Climatical Characteristics | | |
| Upper temperature | IEC 60512-11-9 | + 100 °C |
| Lower temperature | IEC 60512-11-10 | - 40 °C |
| Mechanical Characteristics | | |
| Mechanical operation | IEC 60512-9-1 | ≥ 500 mating cycles |
| Materials | | |
| Male contact | | Cu Zn (brass) |
| Female contact | | Cu Zn (brass) |
| Contact plating | | Ag (silver) / Au (gold) |

heavy|mate® D Stamped crimp contacts

| Supplied as | for wire gauge | AWG | Pieces | Part Number | | Figure |
|---|---|-------------------|---------------|-------------------|-------------------|---|
| | | | | Male contact | Female contact | |
| Stamped single contacts | | | | | | |
| silver plating standard | 0.14 - 0.5 mm ² | 26 - 20 | 100 | VN01 016 0003 (1) | VN02 016 0003 (1) |  |
| | 0.5 - 1.5 mm ² | 20 - 16 | 100 | VN01 016 0002 (1) | VN02 016 0002 (1) | |
| | 1.5 - 2.5 mm ² | 16 - 14 | 100 | VN01 016 0005 (1) | VN02 016 0005 (1) | |
| silver plating high current | 0.5 - 1.5 mm ² | 20 - 16 | 100 | VN01 016 0015 (1) | VN02 016 0015 (1) | |
| | 1.5 - 2.5 mm ² | 16 - 14 | 100 | VN01 016 0016 (1) | VN02 016 0016 (1) | |
| gold plating standard | 0.14 - 0.5 mm ² | 26 - 20 | 100 | VN01 016 0003 (2) | VN02 016 0003 (2) | |
| | 0.5 - 1.5 mm ² | 20 - 16 | 100 | VN01 016 0002 (2) | VN02 016 0002 (2) | |
| | 1.5 - 2.5 mm ² | 16 - 14 | 100 | VN01 016 0005 (2) | VN02 016 0005 (2) | |
| Stamped Contacts on reel for hand crimp tools | | | | | | |
| silver plating standard | 0.14 - 0.5 mm ² | 26 - 20 | 200 | ZN01 016 0003 (1) | ZN02 016 0003 (1) |  |
| | 0.5 - 1.5 mm ² | 20 - 16 | 200 | ZN01 016 0002 (1) | ZN02 016 0002 (1) | |
| | 1.5 - 2.5 mm ² | 16 - 14 | 200 | ZN01 016 0005 (1) | ZN02 016 0005 (1) | |
| silver plating high current | 0.5 - 1.5 mm ² | 20 - 16 | 200 | ZN01 016 0015 (1) | ZN02 016 0015 (1) | |
| | 1.5 - 2.5 mm ² | 16 - 14 | 100 | ZN01 016 0016 (1) | ZN02 016 0016 (1) | |
| gold plating standard | 0.14 - 0.5 mm ² | 26 - 20 | 200 | ZN01 016 0003 (2) | ZN02 016 0003 (2) | |
| | 0.5 - 1.5 mm ² | 20 - 16 | 200 | ZN01 016 0002 (2) | ZN02 016 0002 (2) | |
| | 1.5 - 2.5 mm ² | 16 - 14 | 200 | ZN01 016 0005 (2) | ZN02 016 0005 (2) | |
| Stamped contacts on reel for crimp machines contact feeding left hand side | | | | | | |
| silver plating standard | 0.14 - 0.5 mm ² | 26 - 20 | 2000 | TN01 016 0003 (1) | TN02 016 0003 (1) |  |
| | 0.5 - 1.5 mm ² | 20 - 16 | 2000 | TN01 016 0002 (1) | TN02 016 0002 (1) | |
| | 1.5 - 2.5 mm ² | 16 - 14 | 2000 | TN01 016 0005 (1) | TN02 016 0005 (1) | |
| silver plating high current | 0.5 - 1.5 mm ² | 20 - 16 | 2000 | TN01 016 0015 (1) | TN02 016 0015 (1) | |
| | 1.5 - 2.5 mm ² | 18 - 14 | 2000 | TN01 016 0016 (1) | TN02 016 0016 (1) | |
| gold plating standard | 0.14 - 0.5 mm ² | 26 - 20 | 2000 | TN01 016 0003 (2) | TN02 016 0003 (2) | |
| | 0.5 - 1.5 mm ² | 20 - 16 | 2000 | TN01 016 0002 (2) | TN02 016 0002 (2) | |
| | 1.5 - 2.5 mm ² | 16 - 14 | 2000 | TN01 016 0005 (2) | TN02 016 0005 (2) | |
| Tools for stamped crimp contacts | | | | | | |
| Description | for wire gauge | Part Number | | | | |
| | | Contact locator | Crimping dies | Tool | | |
| Removal tool for contacts | - | - | - | FG 0300 146 1 | | |
| Service crimping tool | 0.14 - 0.5 mm ² 0.5 - 1.5 mm ² | - | - | TA 0100 146 | | |
| Crimping tool for single contacts | 0.14 - 0.5 mm ² | TA 0001 146 000 1 | TA 0000 202 | TA 0000 | | |
| | 0.5 - 1.5 mm ² | TA 0002 146 000 1 | TA 0000 163 | TA 0500 | | |
| | 1.5 - 2.5 mm ² | TA 0007 146 000 3 | TA 0000 141 | | | |
| Further tools see catalogue "Tools" | | | | | | |

heavy|mate® D Turned crimp contacts



| Supplied as | for wire gauge | AWG | Pieces | Part Number | | Figure |
|---|---|-----------------|---------------|--------------------|--------------------|---|
| | | | | Male contact | Female contact | |
| Turned crimp contacts single contact | | | | | | |
| silver plating | 0.14 - 0.37 mm ² | 26 - 22 | 100 | VN01 016 0024 (1)C | VN02 016 0024 (1)C |  |
| | 0.5 mm ² | 20 | 100 | VN01 016 0025 (1)C | VN02 016 0025 (1)C | |
| | 0.75 - 1.0 mm ² | 20 - 16 | 100 | VN01 016 0026 (1)C | VN02 016 0026 (1)C | |
| | 1.5 mm ² | 16 - 15 | 100 | VN01 016 0027 (1)C | VN02 016 0027 (1)C | |
| | 2.5 mm ² | 14 | 100 | VN01 016 0028 (1)C | VN02 016 0028 (1)C | |
| gold plating | 0.14 - 0.37 mm ² | 26 - 22 | 100 | VN01 016 0024 (2)C | VN02 016 0024 (2)C | |
| | 0.5 mm ² | 20 | 100 | VN01 016 0025 (2)C | VN02 016 0025 (2)C | |
| | 0.75 - 1.0 mm ² | 20 - 16 | 100 | VN01 016 0026 (2)C | VN02 016 0026 (2)C | |
| | 1.5 mm ² | 16 - 15 | 100 | VN01 016 0027 (2)C | VN02 016 0027 (2)C | |
| | 2.5 mm ² | 14 | 100 | VN01 016 0028 (2)C | VN02 016 0028 (2)C | |
| Tools for turned crimp contacts | | | | | | |
| Description | for wire gauge | Part Number | | | | |
| | | Contact locator | Crimping dies | Tool | | |
| Removal tool for contacts | - | - | - | FG 0300 146 1 | | |
| Service crimping tool | 0.14 - 0.5 mm ² 0.5 - 1.5 mm ² | - | - | TA 0100 146 | | |
| Further tools see catalogue "Tools" | | | | | | |

A high-speed train, silver with orange and black accents, is shown from a front-quarter perspective on a track. The train is moving towards the viewer. Above the train, a complex network of overhead power lines and support poles stretches into the distance. The background consists of green trees and a clear sky. The train's front features a large windshield and two sets of headlights on either side. The tracks are made of steel rails on a concrete bed, with gravel on the sides.

heavy | mate[®] DD

- Rated voltage 250 V
- Rated current 8 A ... 9 A
- Termination: crimp
- Number of contacts: 24, 42, 72, 108



| Approvals, Testhouse | Characteristics | Approval-Number |
|--|-----------------|-----------------|
| SEV  | 250 V, 10 A | |
| UL  | 600 V, 8,5 A | E 63093 |
| CSA  | 600 V, 10 A | LR 700721 |

In general approvals refer to representative versions of the connector series. Extent and specification of tests upon request.

| General Characteristics | | Standard | Value | | | |
|---------------------------------------|-----------------|----------|--|--------|------------|---------|
| Number of contacts | | | 24 + ⊕ | 42 + ⊕ | 72 + ⊕ | 108 + ⊕ |
| Termination technique | | | crimp | | | |
| Wire gauge | | | 0.14 mm ² - 2.5 mm ² | | | |
| Flammability | UL 94 | | V-0 | | | |
| Electrical Characteristics | | | | | | |
| Rated voltage | IEC 60664-1 | | 250 V (600 V UL / CSA) | | | |
| Pollution degree | IEC 60664-1 | | 2 (3 mated and locked) | | | |
| Installation (overvoltage) category | IEC 60664-1 | | III | | | |
| Material group | IEC 60664-1 | | III b | | | |
| Rated impulse withstand voltage | IEC 60664-1 | | 4 kV | | | |
| Current carrying capacity | IEC 60512-5-2 | | see derating curves | | | |
| Contact resistance | IEC 60512-2-1 | | ≤ 5 m Ω | | | |
| Insulation resistance | IEC 60512-3-1 | | ≥ 10 ¹⁰ Ω | | | |
| Climatical Characteristics | | | | | | |
| Climatic category | IEC 60068-1 | | 40 / 100 / 21 | | | |
| Upper temperature | IEC 60512-11-9 | | + 100 °C | | | |
| Lower temperature | IEC 60512-11-10 | | - 40 °C | | | |
| Mechanical Characteristics | | | | | | |
| Weight pin insert | | | 44 g | 50 g | 63 g | 86 g |
| IP-degree of protection pin insert | IEC 60529 | | unmated IP00 | | mated IP20 | |
| IP-degree of protection socket insert | IEC 60529 | | unmated IP20 | | mated IP20 | |
| Weight socket insert | | | 41 g | 50 g | 67 g | 88 g |
| Mechanical operation | IEC 60512-9-1 | | > 500 mating cycles | | | |
| Materials | | | | | | |
| Insert | | | PBTP | | | |
| Colour insert | | | grey | | | |
| Contacts | | | CuZn (brass) | | | |
| Contact plating | | | Ag (silver) | | | |

Derating curves

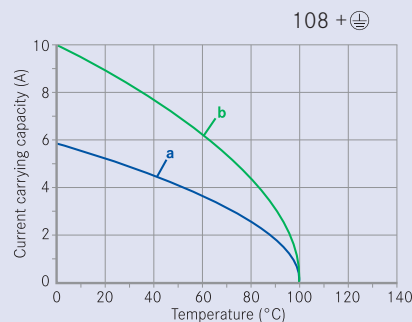
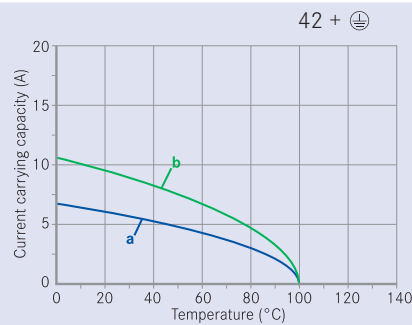

| Description | Part Number | Drawing | Figure |
|--|-------------------|---------|--------|
| Contact insert 24 + ⊕ for turned contacts Size E 6 (Please order contacts separately, see page 43) | | | |
| Male insert for turned crimp contacts | C146 10A024 000 9 | | |
| Female insert for turned crimp contacts | C146 10B024 000 9 | | |
| Contact insert 42 + ⊕ for turned contacts Size E 10 (Please order contacts separately, see page 43) | | | |
| Male insert for turned crimp contacts | C146 10A042 000 9 | | |
| Female insert for turned crimp contacts | C146 10B042 000 9 | | |
| Contact insert 72 + ⊕ for turned contacts Size E 16 (Please order contacts separately, see page 43) | | | |
| Male insert for turned crimp contacts | C146 10A072 000 9 | | |
| Female insert for turned crimp contacts | C146 10B072 000 9 | | |

Description **Part Number** **Drawing** **Figure**

Contact insert 108 + ⊕ for turned contacts Size E 24 (Please order contacts separately, see page 43)

| | | | |
|--|-------------------|--|--|
| Male insert for turned crimp contacts | C146 10A108 000 9 | | |
|--|-------------------|--|--|

| | | | |
|--|-------------------|--|--|
| Female insert for turned crimp contacts | C146 10B108 000 9 | | |
|--|-------------------|--|--|

Contact insert 216 + ⊕ for turned contacts Size E 48 (Please order contacts separately, see page 43)

| | | | |
|--|---|--|--|
| Male insert for turned crimp contacts | C146 10A108 000 9 + C146 10A108 005 9 | | |
|--|---|--|--|

| | | | |
|--|---|--|--|
| Female insert for turned crimp contacts | C146 10B108 000 9 + C146 10B108 005 9 | | |
|--|---|--|--|

Pin layout **Assembly instruction**

| <p>Male insert Female insert</p> <p>X - 4 (24 pol.) 7 (42 pol.) 12 (72 pol.) 18 (108 pol.)</p> | <p>Panel cut out (insert)</p> <table border="1"> <thead> <tr> <th>Pol.</th> <th>A</th> <th>B</th> </tr> </thead> <tbody> <tr> <td>24</td> <td>35</td> <td>44</td> </tr> <tr> <td>42</td> <td>48</td> <td>57</td> </tr> <tr> <td>72</td> <td>69</td> <td>77.5</td> </tr> <tr> <td>108</td> <td>95</td> <td>104</td> </tr> </tbody> </table> | Pol. | A | B | 24 | 35 | 44 | 42 | 48 | 57 | 72 | 69 | 77.5 | 108 | 95 | 104 |
|---|--|------|---|---|----|----|----|----|----|----|----|----|------|-----|----|-----|
| Pol. | A | B | | | | | | | | | | | | | | |
| 24 | 35 | 44 | | | | | | | | | | | | | | |
| 42 | 48 | 57 | | | | | | | | | | | | | | |
| 72 | 69 | 77.5 | | | | | | | | | | | | | | |
| 108 | 95 | 104 | | | | | | | | | | | | | | |

heavy|mate® DD Crimp contacts

| Supplied as | for wire gauge | AWG | Pieces | Part Number | | Figure |
|---|---|-----------------|---------------|--------------------|--------------------|---|
| | | | | Male contact | Female contact | |
| Turned crimp contacts single contact 1.6mm | | | | | | |
| silver plating | 0.14 - 0,37 mm ² | 26 - 22 | 100 | VN01 016 0024 (1)C | VN02 016 0024 (1)C |  |
| | 0.5 mm ² | 20 | 100 | VN01 016 0025 (1)C | VN02 016 0025 (1)C | |
| | 0.75 - 1,0 mm ² | 20 - 16 | 100 | VN01 016 0026 (1)C | VN02 016 0026 (1)C | |
| | 1.5 mm ² | 16 - 15 | 100 | VN01 016 0027 (1)C | VN02 016 0027 (1)C | |
| | 2.5 mm ² | 14 | 100 | VN01 016 0028 (1)C | VN02 016 0028 (1)C | |
| gold plating | 0.14 - 0.37 mm ² | 26 - 22 | 100 | VN01 016 0024 (2)C | VN02 016 0024 (2)C | |
| | 0.5 mm ² | 20 | 100 | VN01 016 0025 (2)C | VN02 016 0025 (2)C | |
| | 0.75 - 1.0 mm ² | 20 - 16 | 100 | VN01 016 0026 (2)C | VN02 016 0026 (2)C | |
| | 1.5 mm ² | 16 - 15 | 100 | VN01 016 0027 (2)C | VN02 016 0027 (2)C | |
| | 2.5 mm ² | 14 | 100 | VN01 016 0028 (2)C | VN02 016 0028 (2)C | |
| Tools for turned crimp contacts | | | | | | |
| Description | for wire gauge | Part Number | | | | |
| | | Contact locator | Crimping dies | Tool | | |
| Removal tool for contacts | - | - | - | FG 0300 146 1 | | |
| Service crimping tool | 0.14 - 0.5 mm ² 0.5 - 1.5 mm ² | - | - | TA 0100 146 | | |
| Further tools see catalogue "Tools" | | | | | | |



heavy | mate[®] E

- Rated voltage 500 V
- Rated current 16 A ... 22 A
- Termination: screw, crimp, tension spring
- Numbers of contacts: 6, 10, 16, 24, 48



| Approvals, Testhouse | Characteristics | Approval-Number |
|----------------------|-----------------|-----------------|
| SEV | 400 V, 16 A | |
| UL | 600 V, 16 A | E 63093 |
| CSA | 600 V, 16 A | 48932 |

In general approvals refer to representative versions of the connector series. Extent and specification of tests upon request.

General information

- Contact inserts without crimp contacts.
- Connectors series heavy|mate® E may be engaged or disengaged when live but without electrical load. If these connectors are mated or unmated under load, the load shall be reduced to 10 % of the rated current.
- Crimping tools and processing instructions see separate catalogue „Tools“.
- Low and high profile housings are usable.
- If wire ferrule are used, screw terminals without wire protection are preferred.



No standard for this series, but:

Interchangeable with other products

- a) contact insert to contact insert 6, 10, 16, 24 contacts
- b) contact insert to housing 6, 10, 16, 24 contacts

Housings are designed according to DIN EN 175 301 - 801

First-to-mate last-to-break protective ground contact



Contact inserts for screw termination, screw termination with wire protection and for crimp termination



Screw termination



Screw termination with wire protection



Crimp termination

Range of housings

Size E6



Size E10



Size E16



Size E24



Size E48



| General Characteristics | Standard | Value | | | | |
|---|-----------------|--|--------|--------|------------|--------|
| Number of contacts | | 6 + ⊖ | 10 + ⊖ | 16 + ⊖ | 24 + ⊖ | 48 + ⊖ |
| Termination technique | | crimp / screw / tension spring | | | | |
| Wire gauge | | 0.5 - 4 mm ² | | | | |
| Flammability | UL 94 | V-0 | | | | |
| Electrical Characteristics | | | | | | |
| Rated voltage | IEC 60664-1 | max. 500 V (600 V UL / CSA ¹⁾) | | | | |
| Pollution degree | IEC 60664-1 | 3 | | | | |
| Material group | IEC 60664-1 | III b | | | | |
| Installation (overvoltage) category | IEC 60664-1 | III | | | | |
| Rated impulse withstand voltage | IEC 60664-1 | 6,0 kV | | | | |
| Current carrying capacity | IEC 60512-5-2 | see derating curves | | | | |
| Rated current T _{amp} = 40 °C | | 22 A | 19 A | 19 A | 18 A | 18 A |
| Contact resistance | IEC 60512-2-1 | < 5 mΩ | | | | |
| Insulation resistance | IEC 60512-3-1 | ≥ 10 ¹⁰ Ω | | | | |
| Climatical Characteristics | | | | | | |
| Climatic category | IEC 60068-1 | 40 / 125 / 21 | | | | |
| Upper temperature | IEC 60512-11-9 | + 125 °C | | | | |
| Lower temperature | IEC 60512-11-10 | - 40°C | | | | |
| Mechanical Characteristics | | | | | | |
| IP-degree of protection pin insert ²⁾ | IEC 60529 | unmated IP00 | | | mated IP20 | |
| IP-degree of protection socket insert ²⁾ | IEC 60529 | unmated IP20 | | | mated IP20 | |
| Weight: | | | | | | |
| male insert crimp (for stamped contacts) | | 33 g | 39 g | 45 g | 55 g | 110 g |
| female insert crimp (for stamped contacts) | | 33 g | 39 g | 49 g | 62 g | 124 g |
| male insert screw | | 43 g | 57 g | 78 g | 105 g | 210 g |
| female insert screw | | 43 g | 57 g | 78 g | 106 g | 212 g |
| Mechanical operation | IEC 60512-9-1 | > 500 mating cycles | | | | |
| Materials | | | | | | |
| Insert | | PC GV (Polycarbonat) | | | | |
| Colour insert | | grey | | | | |
| Screw contacts | | CuZn (brass) | | | | |
| Contact plating | | Ag (silver) / Au (gold) | | | | |

| Description | Part Number | Drawing | Figure |
|---|-------------------|---------|--------|
| Screw termination | | | |
| Male insert for screw termination | C146 10A006 002 1 | | |
| Male insert with wire protection for screw termination | C146 10A006 102 1 | | |
| Female insert for screw termination | C146 10B006 002 1 | | |
| Female insert with wire protection for screw termination | C146 10B006 102 1 | | |
| Tension spring | | | |
| Male insert with Tension spring | C146 10A006 400 1 | | |
| Female insert with Tension spring | C146 10B006 400 1 | | |
| Stamped crimp contacts (Please order contacts separately, see page 58) | | | |
| Male insert for stamped crimp contacts | C146 10A006 000 1 | | |
| Female insert for stamped crimp contacts | C146 10B006 000 1 | | |

| Description | Part Number | Drawing | Figure |
|--|-------------------|---------|--------|
| Turned crimp contacts (Please order contacts separately, see page 58) | | | |
| Male insert for turned crimp contacts | C146 10A006 500 1 | | |
| Female insert for turned crimp contacts | C146 10B006 500 1 | | |

| Pin layout | | Assembly instruction | |
|-------------|---------------|------------------------|--|
| Male insert | Female insert | Panel cut out (insert) | |
| | | | |

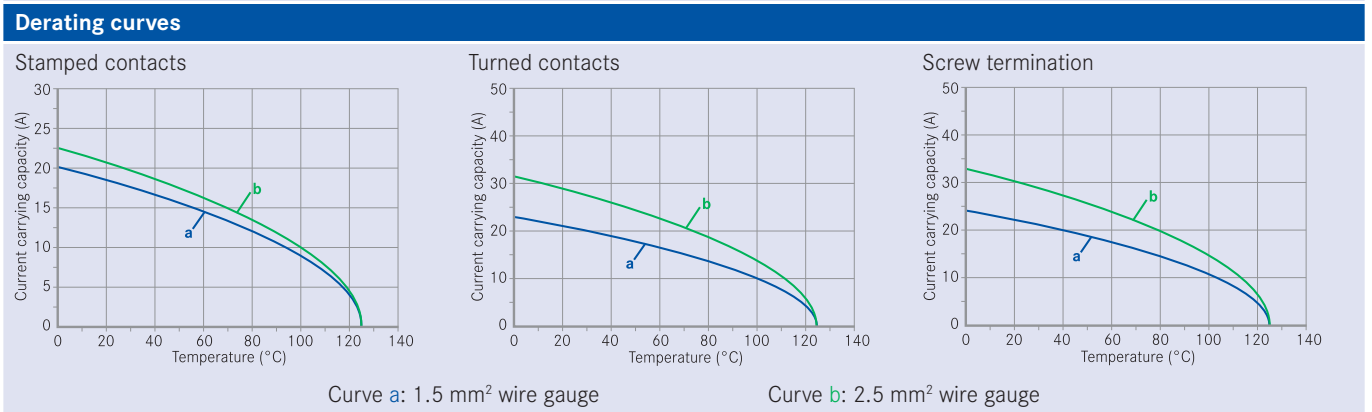

| Description | Part Number | Drawing | Figure |
|---|-------------------|---------|--------|
| Screw termination | | | |
| Male insert for screw termination | C146 10A010 002 1 | | |
| Male insert with wire protection for screw termination | C146 10A010 102 1 | | |
| Female insert for screw termination | C146 10B010 002 1 | | |
| Female insert with wire protection for screw termination | C146 10B010 102 1 | | |
| Tension spring | | | |
| Male insert with Tension spring | C146 10A010 400 1 | | |
| Female insert with Tension spring | C146 10B010 400 1 | | |
| Stamped crimp contacts (Please order contacts separately, see page 58) | | | |
| Male insert for stamped crimp contacts | C146 10A010 000 1 | | |
| Female insert for stamped crimp contacts | C146 10B010 000 1 | | |

| Description | Part Number | Drawing | Figure |
|--|-------------------|---------|--------|
| Turned crimp contacts (Please order contacts separately, see page 58) | | | |
| Male insert for turned crimp contacts | C146 10A010 500 1 | | |
| Female insert for turned crimp contacts | C146 10B010 500 1 | | |

| Pin layout | | Assembly instruction | |
|-------------|---------------|------------------------|--|
| Male insert | Female insert | Panel cut out (insert) | |
| | | | |

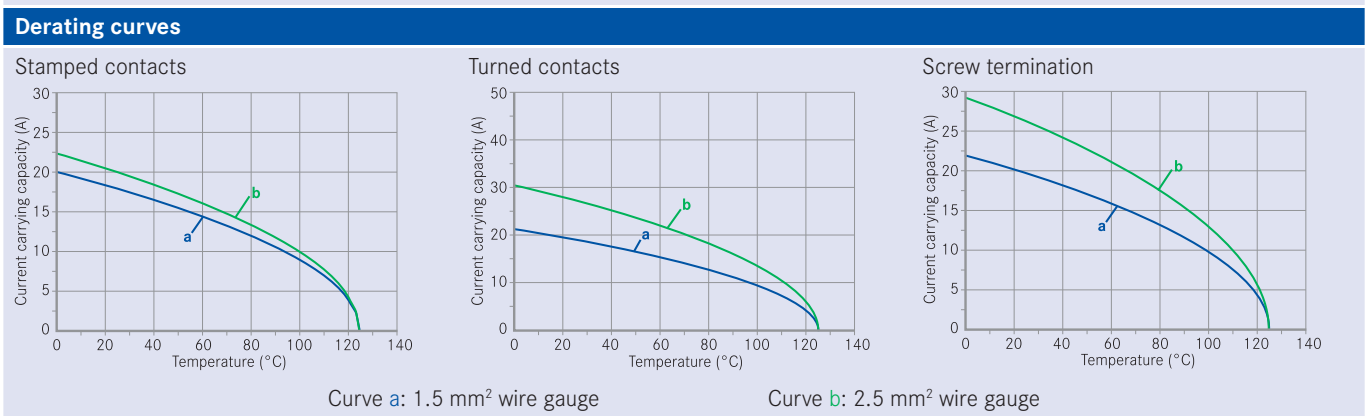

| Description | Part Number | Drawing | Figure |
|---|-------------------|---------|--------|
| Screw termination | | | |
| Male insert for screw termination | C146 10A016 002 1 | | |
| Male insert with wire protection for screw termination | C146 10A016 102 1 | | |
| Female insert for screw termination | C146 10B016 002 1 | | |
| Female insert with wire protection for screw termination | C146 10B016 102 1 | | |
| Tension spring | | | |
| Male insert with Tension spring | C146 10A016 400 1 | | |
| Female insert with Tension spring | C146 10B016 400 1 | | |
| Stamped crimp contacts (Please order contacts separately, see page 58) | | | |
| Male insert for stamped crimp contacts | C146 10A016 000 1 | | |
| Female insert for stamped crimp contacts | C146 10B016 000 1 | | |

| Description | Part Number | Drawing | Figure |
|--|-------------------|---------|--------|
| Turned crimp contacts (Please order contacts separately, see page 58) | | | |
| Male insert for turned crimp contacts | C146 10A016 500 1 | | |
| Female insert for turned crimp contacts | C146 10B016 500 1 | | |

| Pin layout | | Assembly instruction | |
|-------------|---------------|------------------------|--|
| Male insert | Female insert | Panel cut out (insert) | |
| | | | |

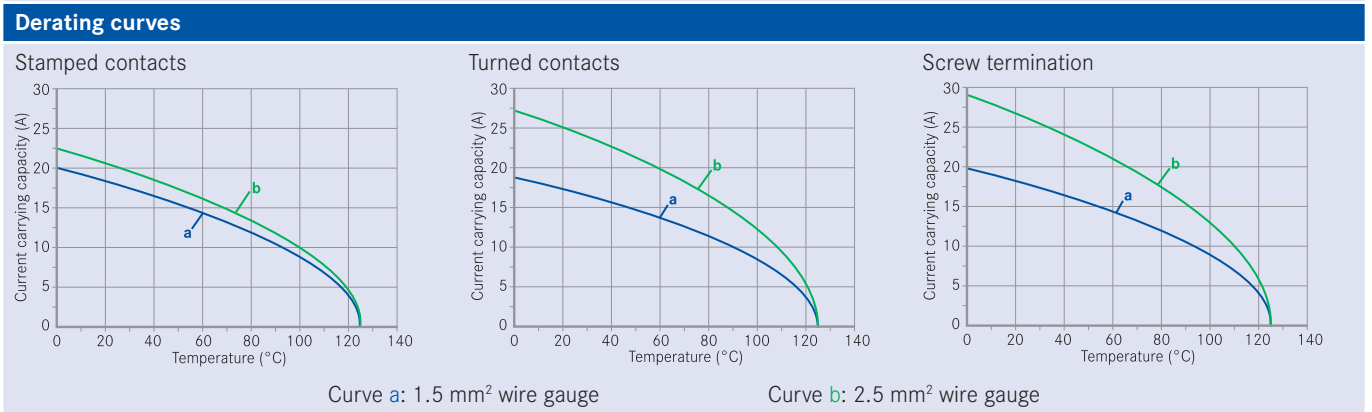

| Description | Part Number | Drawing | Figure |
|---|-------------------|---------|--------|
| Screw termination | | | |
| Male insert for screw termination | C146 10A024 002 1 | | |
| Male insert with wire protection for screw termination | C146 10A024 102 1 | | |
| Female insert for screw termination | C146 10B024 002 1 | | |
| Female insert with wire protection for screw termination | C146 10B024 102 1 | | |
| Tension spring | | | |
| Male insert with Tension spring | C146 10A024 400 1 | | |
| Female insert with Tension spring | C146 10B024 400 1 | | |
| Stamped crimp contacts (Please order contacts separately, see page 58) | | | |
| Male insert for stamped crimp contacts | C146 10A024 000 1 | | |
| Female insert for stamped crimp contacts | C146 10B024 000 1 | | |

Description | **Part Number** | **Drawing** | **Figure**

Turned crimp contacts (Please order contacts separately, see page 58)

Male insert
for turned crimp contacts

C146 10A024 500 1

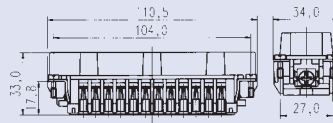

Female insert
for turned crimp contacts

C146 10B024 500 1

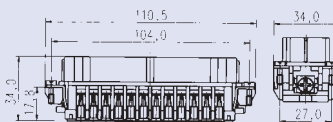

Pin layout

Assembly instruction

Male insert

Female insert

Panel cut out (insert)

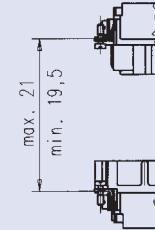
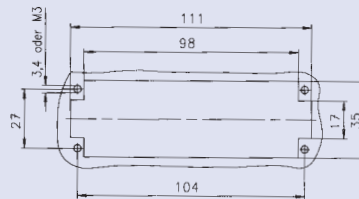

Derating curves

Stamped contacts

Turned contacts

Screw termination

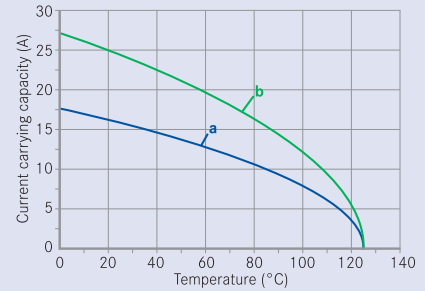
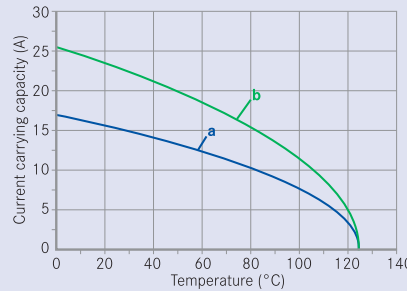
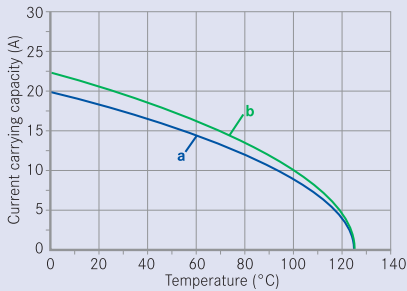

Curve a: 1.5 mm² wire gauge

Curve b: 2.5 mm² wire gauge

| Description | Part Number | Drawing | Figure |
|---|---|---------|--------|
| Screw termination | | | |
| Male insert for screw termination | C146 10A024 002 1 + C146 10A024 002 1 | | |
| Male insert with wire protection for screw termination | C146 10A024 102 1 + C146 10A024 102 1 | | |
| Female insert for screw termination | C146 10B024 002 1 + C146 10B024 002 1 | | |
| Female insert with wire protection for screw termination | C146 10B024 102 1 + C146 10B024 102 1 | | |
| Stamped crimp contacts (Please order contacts separately, see page 58) | | | |
| Male insert for stamped crimp contacts | C146 10A024 000 1 + C146 10A024 005 1 | | |
| Female insert for stamped crimp contacts | C146 10B024 000 1 + C146 10B024 005 1 | | |
| Turned crimp contacts (Please order contacts separately, see page 58) | | | |
| Male insert for turned crimp contacts | C146 10A024 500 1 + C146 10A024 505 1 | | |
| Female insert for turned crimp contacts | C146 10B024 500 1 + C146 10B024 505 1 | | |

Pin layout

Male insert

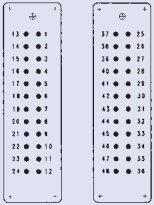

Female insert

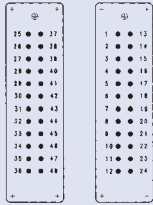

Assembly instruction

Panel cut out (insert)

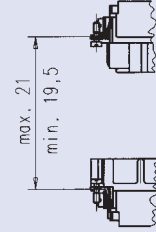
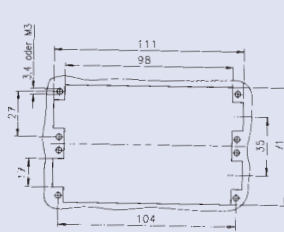

Derating curves

Stamped contacts

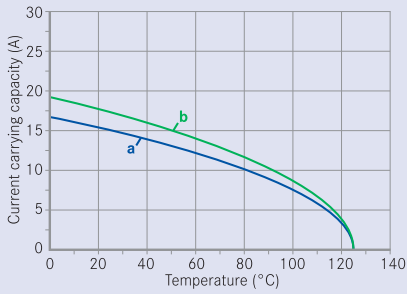

Curve a: 1.5 mm² wire gauge

Turned contacts

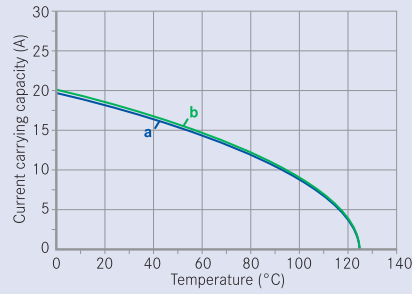

Curve b: 2.5 mm² wire gauge

Screw termination

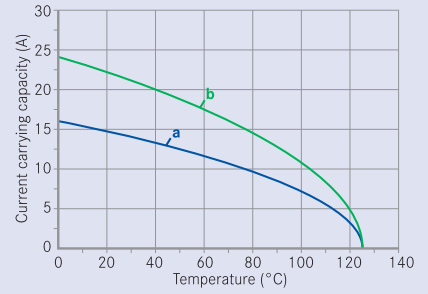

Large range of wire gauges

N01 025 0001 (1)



N01 025 0010 (1)



Gas-tight (coldwelding)

0,5



1,0



1,5



1,5



2,5



Stamped crimp contacts with insulation crimp, to absorb mechanical stress from the crimped connection

Insulation grip

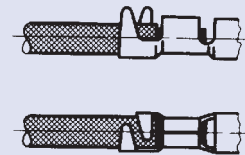
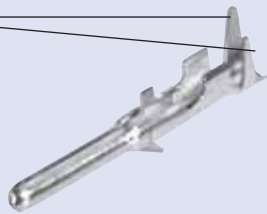

Mechanical retention spring stop on female and male contact

Female contact

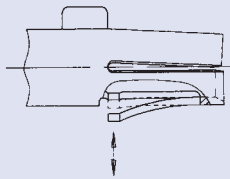

Male contact

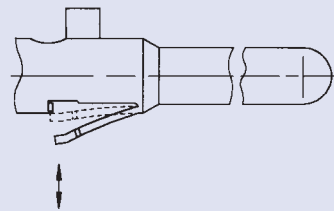

High current carrying capacity

Example single contact

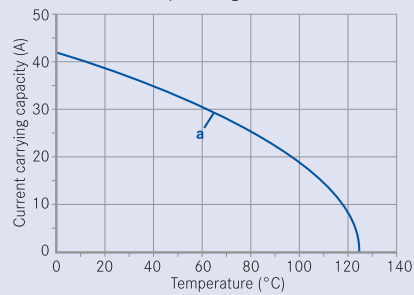

Curve a: 2.5 mm² wire gauge

| Stamped crimp contacts | | |
|-----------------------------------|-----------------|-------------------------|
| Electrical Characteristics | | |
| Contact resistance | IEC 60512-2-1 | < 5 m Ω |
| Mechanical Characteristics | | |
| Mechanical operation | IEC 60512-9-1 | ≥ 500 mating cycles |
| Materials | | |
| Male contact | | Cu Zn (brass) |
| Female contact | | Cu Sn (tin bronze) |
| Contact plating | | Ag (silver) / Au (gold) |
| Turned crimp contacts | | |
| Electrical Characteristics | | |
| Contact resistance | IEC 60512-2-1 | ≤ 5 m Ω |
| Climatical Characteristics | | |
| Upper temperature | IEC 60512-11-9 | + 125 °C |
| Lower temperature | IEC 60512-11-10 | - 40 °C |
| Mechanical Characteristics | | |
| Mechanical operation | IEC 60512-9-1 | ≥ 500 mating cycles |
| Materials | | |
| Male contact | | Cu Zn (brass) |
| Female contact | | Cu Zn (brass) |
| Contact plating | | Ag (silver) / Au (gold) |

heavy|mate® E Stamped crimp contacts

| Supplied as | for wire gauge | AWG | Pieces | Part Number | | Figure |
|---|---------------------------|-------------------|---------------|---------------------|---------------------|--|
| | | | | Male contact | Female contact | |
| Stamped single contacts | | | | | | |
| silver plating | 0.5 - 1.5 mm ² | 20 - 16 | 100 | VN01 025 0001 (101) | VN02 025 0001 (101) |  |
| | 1.5 - 2.5 mm ² | 16 - 14 | 100 | VN01 025 0010 (101) | VN02 025 0010 (101) | |
| gold plating | 0.5 - 1.5 mm ² | 20 - 16 | 100 | VN01 025 0001 (102) | VN02 025 0001 (102) | |
| | 1.5 - 2.5 mm ² | 16 - 14 | 100 | VN01 025 0010 (102) | VN02 025 0010 (102) | |
| Stamped Contacts on reel for hand crimp tools | | | | | | |
| silver plating | 0.5 - 1.5 mm ² | 20 - 16 | 200 | ZN01 025 0001 (1) | ZN02 025 0001 (1) |  |
| | 1.5 - 2.5 mm ² | 16 - 14 | 100 | ZN01 025 0010 (1) | ZN02 025 0010 (1) | |
| gold plating | 0.5 - 1.5 mm ² | 20 - 16 | 200 | ZN01 025 0001 (2) | ZN02 025 0001 (2) | |
| | 1.5 - 2.5 mm ² | 16 - 14 | 100 | ZN01 025 0010 (2) | ZN02 025 0010 (2) | |
| Stamped contacts on reel for crimp machines contact feeding left hand side | | | | | | |
| silver plating | 0.5 - 1.5 mm ² | 20 - 16 | 2000 | TN01 025 0001 (1) | TN02 025 0001 (1) |  |
| | 1.5 - 2.5 mm ² | 16 - 14 | 2000 | TN01 025 0010 (1) | TN02 025 0010 (1) | |
| Tools for turned crimp contacts | | | | | | |
| Description | for wire gauge | Part Number | | | | |
| | | Contact locator | Crimping dies | Tool | | |
| Removal tool for contacts | - | - | - | FG 0200 146 1 | | |
| Crimping tool for stamped single contacts | 0.5 - 1.5 mm ² | TA 0004 146 000 1 | TA 0000 163 | TA 0000 | | |
| | 1.5 - 2.5 mm ² | TA 0005 146 000 3 | TA 0000 141 | | | |
| 4-indent crimping tool for turned contacts | 0.5 - 4.0 mm ² | - | - | TB 0600 146 | | |
| Further tools see catalogue "Tools" | | | | | | |

heavy|mate® E Turned crimp contacts



| Supplied as | for wire gauge | AWG | Pieces | Part Number | | Figure |
|---|----------------------------|-------------------|---------------|--------------------|--------------------|---|
| | | | | Male contact | Female contact | |
| Turned crimp contacts single contact | | | | | | |
| silver plating | 0.5 mm ² | 20 | 100 | VN01 025 0035 (1)C | VN02 025 0035 (1)C |  |
| | 0.75 - 1.0 mm ² | 18 | 100 | VN01 025 0036 (1)C | VN02 025 0036 (1)C | |
| | 1.5 mm ² | 16 | 100 | VN01 025 0037 (1)C | VN02 025 0037 (1)C | |
| | 2.5 mm ² | 14 | 100 | VN01 025 0038 (1)C | VN02 025 0038 (1)C | |
| | 4.0 mm ² | 12 | 100 | VN01 025 0039 (1)C | VN02 025 0039 (1)C | |
| gold plating | 0.5 mm ² | 20 | 100 | VN01 025 0035 (2)C | VN02 025 0035 (2)C | |
| | 0.75 - 1.0 mm ² | 18 | 100 | VN01 025 0036 (2)C | VN02 025 0036 (2)C | |
| | 1.5 mm ² | 16 | 100 | VN01 025 0037 (2)C | VN02 025 0037 (2)C | |
| | 2.5 mm ² | 14 | 100 | VN01 025 0038 (2)C | VN02 025 0038 (2)C | |
| | 4.0 mm ² | 12 | 100 | VN01 025 0039 (2)C | VN02 025 0039 (2)C | |
| Tools for turned crimp contacts | | | | | | |
| Description | for wire gauge | Part Number | | | | |
| | | Contact locator | Crimping dies | Tool | | |
| Removal tool for contacts | | | | FG 0300 146 7 | | |
| Crimping tool for stamped single contacts | 0.5 - 2.5 mm ² | TA 0010 146 000 6 | TA 0000 144 | TA 0000 | | |
| | 4 mm ² | TA 0010 146 000 7 | TA 0000 124 | TA 0500 | | |
| 4-indent crimping tool for turned contacts | | | | TB 0600 146 | | |
| Further tools see catalogue "Tools" | | | | | | |



heavy | mate[®] EE

- Rated voltage 500 V (600 V UL / CSA)
- Rated current 16 A
- Termination: crimp
- Numbers of contacts: 10, 18, 32, 46



| Approvals, Testhouse | Characteristics | Approval-Number |
|--|-----------------|-----------------------------|
| UL  | 600 V, 15 A | E 63093 |
| CSA  | 600 V, 16 A | 172062-1027396 (LR 48323-2) |

In general approvals refer to representative versions of the connector series. Extent and specification of tests upon request.



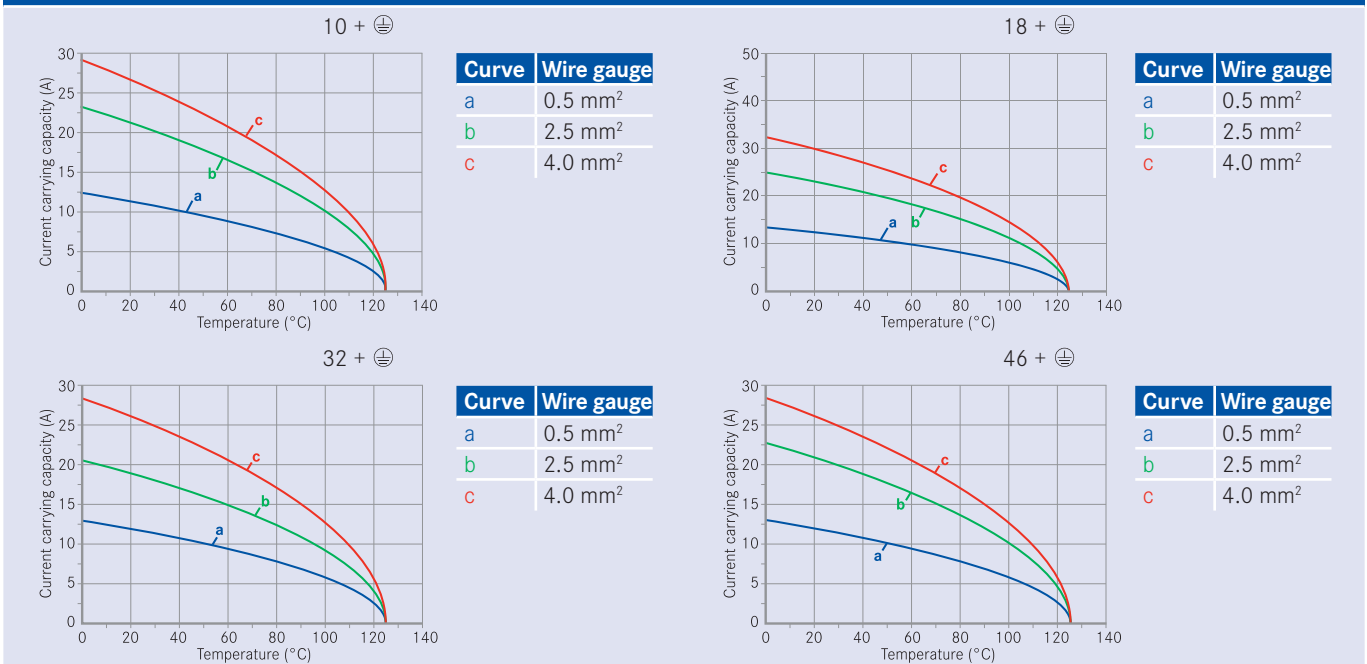

| General Characteristics | Standard | Value |
|---------------------------------------|-----------------|---|
| Number of contacts | | 10 + ⊕ 18 + ⊕ 32 + ⊕ 46 + ⊕ |
| Termination technique | | crimp |
| Wire gauge | | 0.5 mm ² - 4.0 mm ² |
| Flammability | UL 94 | V-0 |
| Electrical Characteristics | | |
| Rated voltage | IEC 60664-1 | 500 V (600 V UL / CSA) |
| Pollution degree | IEC 60664-1 | 3 |
| Installation (overvoltage) category | IEC 60664-1 | III |
| Material group | IEC 60664-1 | III b |
| Rated impulse withstand voltage | IEC 60664-1 | 6 kV |
| Current carrying capacity | IEC 60512-5-2 | see derating curves |
| Contact resistance | IEC 60512-2-1 | ≤ 5 m Ω |
| Insulation resistance | IEC 60512-3-1 | ≥ 10 ¹⁰ Ω |
| Climatical Characteristics | | |
| Climatic category | IEC 60068-1 | 40 / 100 / 21 |
| Upper temperature | IEC 60512-11-9 | + 100 °C |
| Lower temperature | IEC 60512-11-10 | - 40 °C |
| Mechanical Characteristics | | |
| Mechanical operation | IEC 60512-9-1 | > 500 mating cycles |
| IP-degree of protection pin insert | IEC 60529 | unmated IP00 mated IP20 |
| IP-degree of protection socket insert | IEC 60529 | unmated IP20 mated IP20 |
| Materials | | |
| Insert | | PC |
| Colour insert | | grey |
| Contacts | | CuZn (brass) |
| Contact plating | | Ag (silver) / Au (gold) |

Derating curves

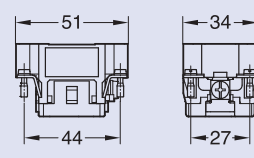

Description **Part Number** **Drawing** **Figure**

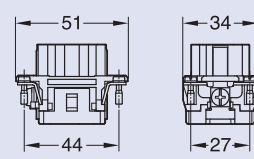

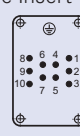
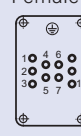
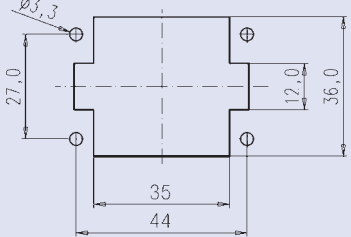

Contact insert 10 + ⊕ Size E 6 (Please order contacts separately, see page 67)

| | | | |
|--|--------------------|--|---|
| Male insert for turned crimp contacts | C146 10A010 500 10 |  |  |
| Female insert for turned crimp contacts | C146 10B010 500 10 |  |  |

| | | | |
|---|---|--|--|
| Pin layout | | Assembly instruction | |
| Male insert  | Female insert  | Panel cut out (insert)  | |

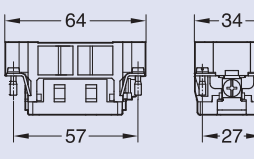
Description **Part Number** **Drawing** **Figure**

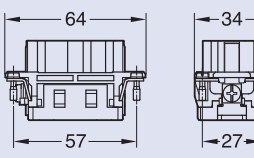
Contact insert 18 + ⊕ Size E 10 (Please order contacts separately, see page 67)

| | | | |
|--|--------------------|--|---|
| Male insert for turned crimp contacts | C146 10A018 500 10 |  |  |
| Female insert for turned crimp contacts | C146 10B018 500 10 |  |  |

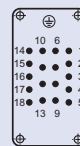
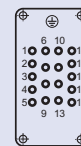
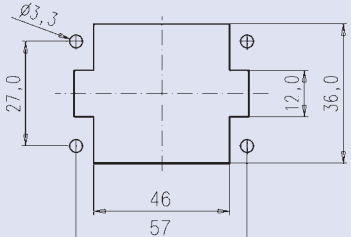
| | | | |
|--|--|---|--|
| Pin layout | | Assembly instruction | |
| Male insert  | Female insert  | Panel cut out (insert)  | |

| Description | Part Number | Drawing | Figure |
|-------------|-------------|---------|--------|
|-------------|-------------|---------|--------|

Contact insert 32 + Ⓢ Size E 16 (Please order contacts separately, see page 67)

| | | | |
|--|--------------------|--|--|
| Male insert for turned crimp contacts | C146 10A032 500 10 | | |
| Female insert for turned crimp contacts | C146 10B032 500 10 | | |

| Pin layout | Assembly instruction |
|---|-------------------------------|
| <p>Male insert</p> <p>Female insert</p> | <p>Panel cut out (insert)</p> |

| Description | Part Number | Drawing | Figure |
|-------------|-------------|---------|--------|
|-------------|-------------|---------|--------|

Contact insert 46 + Ⓢ Size E 24 (Please order contacts separately, see page 67)

| | | | |
|--|--------------------|--|--|
| Male insert for turned crimp contacts | C146 10A046 500 10 | | |
| Female insert for turned crimp contacts | C146 10B046 500 10 | | |

| Pin layout | Assembly instruction |
|---|-------------------------------|
| <p>Male insert</p> <p>Female insert</p> | <p>Panel cut out (insert)</p> |

| Supplied as | for wire gauge | AWG | Pieces | Part Number | | Figure |
|---|----------------------------|-------------------|---------------|--------------------|--------------------|---|
| | | | | Male contact | Female contact | |
| Turned crimp contacts single contact 2.5mm | | | | | | |
| silver plating | 0.5 mm ² | 20 | 100 | VN01 025 0035 (1)C | VN02 025 0035 (1)C |  |
| | 0.75 - 1.0 mm ² | 18 | 100 | VN01 025 0036 (1)C | VN02 025 0036 (1)C | |
| | 1.5 mm ² | 16 | 100 | VN01 025 0037 (1)C | VN02 025 0037 (1)C | |
| | 2.5 mm ² | 14 | 100 | VN01 025 0038 (1)C | VN02 025 0038 (1)C | |
| | 4.0 mm ² | 12 | 100 | VN01 025 0039 (1)C | VN02 025 0039 (1)C | |
| gold plating | 0.5 mm ² | 20 | 100 | VN01 025 0035 (2)C | VN02 025 0035 (2)C | |
| | 0.75 - 1.0 mm ² | 18 | 100 | VN01 025 0036 (2)C | VN02 025 0036 (2)C | |
| | 1.5 mm ² | 16 | 100 | VN01 025 0037 (2)C | VN02 025 0037 (2)C | |
| | 2.5 mm ² | 14 | 100 | VN01 025 0038 (2)C | VN02 025 0038 (2)C | |
| | 4.0 mm ² | 12 | 100 | VN01 025 0039 (2)C | VN02 025 0039 (2)C | |
| Tools for turned crimp contacts | | | | | | |
| Description | for wire gauge | Part Number | | | | |
| | | Contact locator | Crimping dies | Tool | | |
| Removal tool for contacts | | | | FG 0300 146 7 | | |
| Crimping tool for stamped single contacts | 0.5 - 2.5 mm ² | TA 0010 146 000 6 | TA 0000 144 | TA 0000 | | |
| | 4 mm ² | TA 0010 146 000 7 | TA 0000 124 | TA 0500 | | |
| 4-indent crimping tool for turned contacts | | | | TB 0600 146 | | |
| Further tools see catalogue "Tools" | | | | | | |

The image shows a large industrial facility with a high ceiling, steel beams, and overhead lighting. In the foreground, there is a large, light-colored industrial machine with a white top surface and a black frame. The machine has various components, including a control panel with a black knob and a small display, and a series of brass-colored fittings. A thick black cable is connected to the machine. In the background, there are more industrial machines, some with teal and yellow accents, and a blue overhead crane system. The floor is a polished concrete with yellow safety markings.

heavy | mate[®] E / FE / KO

- Rated voltage 400 V
- Material contacts: iron-constantan
- Rated current 10 A
- Number of contacts: 6, 10, 16, 24



Connectors with iron (FE) and constantan (CO) contacts

are basically used in measuring and control circuits to serve as interface between FE/CO thermocouples and control unit, i. e. temperature control of moulds in injection moulding machines. Through the use of FE/CO connectors in the thermocouple circuit the measuring results are more accurate, thus the tolerance of the temperature control is much narrower.

Amphenol's Industrial Connectors with iron (FE) and Constantan (CO) contacts are used to connect FE/CO thermocouples with electronic signal amplifiers in measuring and control circuits, i. e. for temperature control of moulding machines.

Errors with various combinations

The connection of unlike metals (FE/Brass and CO/Brass) generate thermoelectric voltage errors in the measuring circuit caused by the flow from iron wire to the brass contact or by temperature changes at the contact elements.

| Nominal Temp. | Contact Material | without Thermo Contacts | | with Thermo Contacts | |
|---------------|------------------|-------------------------|----------|----------------------|---------|
| | | MS/FE | MS/KO | FE/FE | KO/KO |
| 100 °C | | + 4 % | - 16 % | - 4 % | - 2 % |
| 200 °C | | + 2.5 % | - 8 % | - 3 % | - 1.5 % |
| 300 °C | | + 1.3 % | - 12.7 % | - 1.3 % | 0 % |
| 400 °C | | + 1.5 % | - 4.5 % | - 1.0 % | 0 % |

By using FE/CO contacts respectively these deviations will be minimized.

Material / Temperature Range

| Temperatur range | Material/measurement procedure |
|--------------------------|---------------------------------|
| < 150 °C | any/Resistance measurement |
| 150 °C - 450 °C | FE-CO (iron/Constantan) |
| 450 °C - approx. 1000 °C | Ni/Cr-Ni (Nickel/Chrome/Nickel) |

Temperature changes cause errors

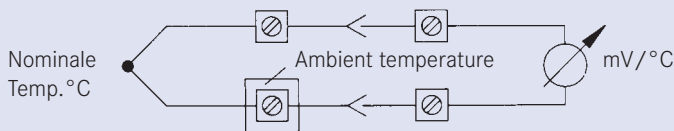

heavy|mate® E / FE / KO Characteristics contact inserts

| General Characteristics | Standard | Value | | | |
|---|-----------------|--|----------------|----------------|----------------|
| Number of contacts | | 6 + \ominus | 10 + \ominus | 16 + \ominus | 24 + \ominus |
| Termination technique | | screw | | | |
| Wire gauge | | 0.25 mm ² - 2.5 mm ² | | | |
| Flammability | UL 94 | V-0 | | | |
| Electrical Characteristics | | | | | |
| Rated voltage | IEC 60664-1 | 500 V | | | |
| Pollution degree | IEC 60664-1 | 3 | | | |
| Installation (overvoltage) category | IEC 60664-1 | III | | | |
| Material group | IEC 60664-1 | III b | | | |
| Current carrying capacity | IEC 60664-1 | 6 kV | | | |
| Rated current T _{amp} = 40 °C | | 10 A | | | |
| Contact resistance | IEC 60512-2-1 | ≤ 10 m Ω | | | |
| Insulation resistance | IEC 60512-3-1 | ≥ 10 ¹⁰ Ω | | | |
| Climatical Characteristics | | | | | |
| Climatic category | IEC 60068-1 | 40 / 100 / 21 | | | |
| Upper temperature | IEC 60512-11-9 | + 100 °C | | | |
| Lower temperature | IEC 60512-11-10 | - 40 °C | | | |
| Mechanical Characteristics | | | | | |
| IP-degree of protection pin insert ¹⁾ | IEC 60529 | unmated IP00 | | mated IP20 | |
| IP-degree of protection socket insert ¹⁾ | IEC 60529 | unmated IP20 | | mated IP20 | |
| Weight pin insert | | 45 g | 60 g | 78 g | 105 g |
| Weight socket insert | | 45 g | 60 g | 78 g | 105 g |
| Mechanical operation | IEC 60512-9-1 | ≥ 100 mating cycles | | | |
| Materials | | | | | |
| Insert | | PA, GV (Polyamid) | | | |
| Colour insert | | grey | | | |
| Contacts | | iron; gal cd 4 constantan = without plating | | | |

| Description | Part Number | Drawing | Figure |
|-------------|-------------|---------|--------|
|-------------|-------------|---------|--------|

Contact insert 6 + ⊕ with iron-constantan contacts

| | | | |
|------------------------------------|-------------------|--|--|
| Male insert with wire protection | C146 10A006 810 1 | | |
| Female insert with wire protection | C146 10B006 810 1 | | |

Pin layout

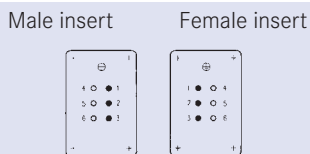

Assembly instruction

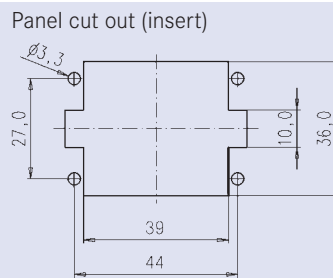

| Description | Part Number | Drawing | Figure |
|-------------|-------------|---------|--------|
|-------------|-------------|---------|--------|

Contact insert 10 + ⊕ with iron-constantan contacts

| | | | |
|------------------------------------|-------------------|--|--|
| Male insert with wire protection | C146 10A010 810 1 | | |
| Female insert with wire protection | C146 10B010 810 1 | | |

Pin layout

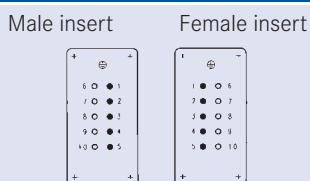

Assembly instruction

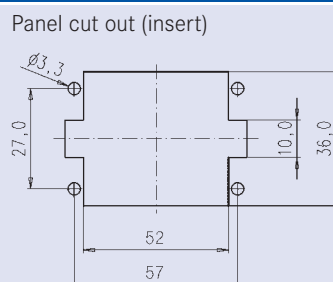

| Description | Part Number | Drawing | Figure |
|-------------|-------------|---------|--------|
|-------------|-------------|---------|--------|

Contact insert 16 + ⊕ with iron-constantan contacts

| | | | |
|------------------------------------|-------------------|--|--|
| Male insert with wire protection | C146 10A016 810 1 | | |
| Female insert with wire protection | C146 10B016 810 1 | | |

Pin layout

Assembly instruction

| | | |
|--------------------|----------------------|-------------------------------|
| <p>Male insert</p> | <p>Female insert</p> | <p>Panel cut out (insert)</p> |
|--------------------|----------------------|-------------------------------|

| Description | Part Number | Drawing | Figure |
|-------------|-------------|---------|--------|
|-------------|-------------|---------|--------|

Contact insert 24 + ⊕ with iron-constantan contacts

| | | | |
|------------------------------------|-------------------|--|--|
| Male insert with wire protection | C146 10A024 810 1 | | |
| Female insert with wire protection | C146 10B024 810 1 | | |

Pin layout

Assembly instruction

| | | |
|--------------------|----------------------|-------------------------------|
| <p>Male insert</p> | <p>Female insert</p> | <p>Panel cut out (insert)</p> |
|--------------------|----------------------|-------------------------------|



heavy | mate[®] F

- **Modular connector**
- **Compatible with market standard**
- **Rated voltage up to 830 V**
- **Rated current up to 40 A**
- **Termination: crimp**
- **Numbers of contacts: 2 - 102**



| Approvals, Testhouse | Characteristics | Approval-Number |
|--|-----------------|-----------------|
| UL  | in preparation | in preparation |
| CSA  | in preparation | in preparation |

General information

- Modules inserts without crimp contacts, crimping tools see separate catalogue “Tools”.
- Contacts must be ordered separately, processing instructions see catalogue “Tools”.
- Connectors series heavy|mate® F may be engaged or disengaged when live but without electrical load.
If these connectors are mated or unmated under load, the load shall be reduced to 10 % of rated current.
- We recommend using the high profile housings / hoods for the heavy|mate® F inserts.
- Empty modul spaces have to be filled with blind modules.
- Torque for PE connection 1.2 Nm



Advantages of the system

- No standard but interchangeable with competitive products.
- Housings are designed according to DIN EN 175 301 801
- Simply connecting of the modules and frames.

First-to-mate last-to-break protective ground contact

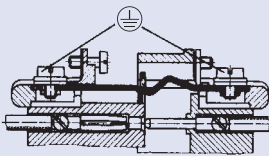

Range of housings

Size E6



Size E10



Size E16



Size E24



Size E48



Requirements

- 3 x 400V; 50A; 6mm² wire gauge
- 8 x 250V; 8A; 1.5mm² wire gauge
- 5 x 400V; 15A; 4mm² wire gauge

Solution

1. Check how 16 contacts can be realized; see modules overview on page 78

Possible selection:

- a) 1 x 17 contacts
- b) 2 x 12 contacts
- c) 1 x 6 contacts + 1 x 12 contacts
- d) 1 x 3 contacts + 1 x 6 contacts + 1 x 12 contacts

2. Check technical parameters / solution, see detail pages of the modules from page 82

Possible selection:

- a) not possible due to voltage
- b) not possible due to voltage
- c) not possible due to current
- d) POSSIBLE

3. Choose matching contact, see detail page of the modules on page 82

Possible selection:

- a) 3 contacts = C146 10A003 500 15 → contacts = VN01 040 0013 1C
- b) 6 contacts = C146 10A006 500 15 → contacts = VN01 025 0039 1C
- c) 12 contacts = C146 10A012 500 15 → contacts = VN01 016 0027 1C

4. Choose matching frame, see frames on page 80

Solution: C146 10P10 000 15

5. Choose matching housing, see housings on page 162

Solution: C146 21R010 600 8

Schematic construction



| Description | Part Number | Drawing | Figure |
|---|--------------------|---------|--------|
| 3 contacts module for turned contacts, details see page 82 | | | |
| Pin modules | C146 10A003 500 15 | | |
| Socket modules | C146 10B003 500 15 | | |
| 6 contacts module for turned contacts, 500V, details see page 84 | | | |
| Pin modules | C146 10A006 500 15 | | |
| Socket modules | C146 10B006 500 15 | | |
| 8 contacts module for turned contacts, 400V, details see page 86 | | | |
| Pin modules | C146 10A008 500 15 | | |
| Socket modules | C146 10B008 500 15 | | |

| Description | Part Number | Drawing | Figure |
|--|--------------------|---------|--------|
| 12 contacts module for turned contacts. 250V, details see page 88 | | | |
| Pin modules | C146 10A012 500 15 | | |
| Socket modules | C146 10B012 500 15 | | |
| 17 contacts module for turned contacts, 160V, details see page 90 | | | |
| Pin modules | C146 10A017 500 15 | | |
| Socket modules | C146 10B017 500 15 | | |
| 20 contacts module for turned contacts 500V, details see page 92 | | | |
| Pin modules | C146 10A020 500 15 | | |
| Socket modules | C146 10B020 500 15 | | |

| Description | Part Number | Drawing | Figure |
|-----------------------------|-------------------|---------|--------|
| Frames for 2 modules | | | |
| Frame for pin modules | C146 10P06 000 15 | | |
| Frame for socket modules | C146 10S06 000 15 | | |
| Frames for 3 modules | | | |
| Frame for pin modules | C146 10P10 000 15 | | |
| Frame for socket modules | C146 10S10 000 15 | | |
| Frames for 4 modules | | | |
| Frame for pin modules | C146 10P16 000 15 | | |
| Frame for socket modules | C146 10S16 000 15 | | |

| Description | Part Number | Drawing | Figure |
|-----------------------------|--------------------|---------|--------|
| Frames for 6 modules | | | |
| Frame for pin modules | C146 10P024 000 15 | | |
| Frame for socket modules | C146 10S024 000 15 | | |

| General Characteristics | Standard | Value |
|-------------------------------------|-----------------|--|
| Number of contacts | | 3 |
| Termination technique | | crimp |
| Wire Gauge | | 1.5 – 6.0 mm ² (AWG 16–10) |
| Flammability | UL94 | V-0 |
| Electrical Characteristics | | |
| Rated voltage | IEC 60664-1 | 400 V (conductor – earth) 690 V (conductor – conductor) |
| Pollution degree | IEC 60664-1 | 3 |
| Installation (overvoltage) category | IEC 60664-1 | III |
| Material group | IEC 60664-1 | II (PA) |
| Rated impulse withstand voltage | IEC 60664-1 | 6 kV |
| Current carrying capacity | IEC 60512-5-2 | see derating curves |
| Contact resistance | IEC 60512-2-1 | ≤ 5 mΩ |
| Insulation resistance | IEC 60512-3-1 | ≥ 10 ¹⁰ Ω |
| Climatical Characteristics | | |
| Climatic category | IEC 60068-1 | 40/125/21 |
| Upper temperature | IEC 60512-11-9 | +125°C |
| Lower temperature | IEC 60512-11-10 | -40°C |
| Mechanical Characteristics | | |
| Mechanical operation | IEC 60512-9-1 | ≥500 mating cycles |
| IP-degree of protection | IEC 60529 | IP00 (pin insert) / IP20 (socket insert) |
| Materials | | |
| Module | | PA6.6 GF |
| Colour module | | black |
| Contact | | CuZn (brass) |
| Contact plating | | Ag (silver) / Au (gold) |

Derating Curves

In preparation

heavy|mate® F 3 contacts module + crimp contacts

| Description | Part Number | Drawing | Figure |
|---|--------------------|---------|--------|
| 3 contacts module (Please order contacts separately) | | | |
| Pin module | C146 10A003 500 15 | | |
| Socket module | C146 10B003 500 15 | | |





| Supplied as | for wire gauge | AWG | Pieces | Part Number | | Figure |
|--|---------------------|-----|--------|------------------|------------------|--------|
| | | | | Male contact | Female contact | |
| Turned 4 mm crimp contacts single contact | | | | | | |
| silver plating | 1.5 mm ² | 16 | 100 | VN01 040 0010 1C | VN02 040 0010 1C | |
| | 2.5 mm ² | 14 | 100 | VN01 040 0011 1C | VN02 040 0011 1C | |
| | 4 mm ² | 12 | 100 | VN01 040 0012 1C | VN02 040 0012 1C | |
| | 6 mm ² | 10 | 100 | VN01 040 0013 1C | VN02 040 0013 1C | |

| General Characteristics | Standard | Value |
|-------------------------------------|-----------------|--|
| Number of contacts | | 6 |
| Termination technique | | crimp |
| Wire Gauge | | 0.5 –4.0 mm ² (AWG 20-12) |
| Flammability | UL94 | V-0 |
| Electrical Characteristics | | |
| Rated voltage | IEC 60664-1 | 500 V |
| Pollution degree | IEC 60664-1 | 3 |
| Installation (overvoltage) category | IEC 60664-1 | III |
| Material group | IEC 60664-1 | II (PA) |
| Rated impulse withstand voltage | IEC 60664-1 | 6 kV |
| Current carrying capacity | IEC 60512-5-2 | see derating curves |
| Contact resistance | IEC 60512-2-1 | ≤ 5 mΩ |
| Insulation resistance | IEC 60512-3-1 | ≥ 10 ¹⁰ Ω |
| Climatical Characteristics | | |
| Climatic category | IEC 60068-1 | 40/125/21 |
| Upper temperature | IEC 60512-11-9 | +125°C |
| Lower temperature | IEC 60512-11-10 | -40°C |
| Mechanical Characteristics | | |
| Mechanical operation | IEC 60512-9-1 | ≥500 mating cycles |
| IP-degree of protection | IEC 60529 | IP00 (pin insert) / IP20 (socket insert) |
| Materials | | |
| Module | | PA6.6 GF |
| Colour module | | black |
| Contact | | CuZn (brass) |
| Contact plating | | Ag (silver) / Au (gold) |

Derating Curves

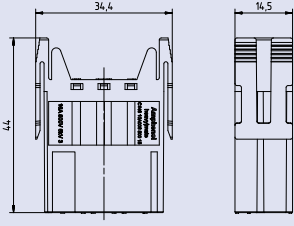
In preparation

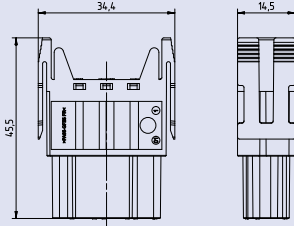
heavy|mate® F 6 contacts module + crimp contacts

| Description | Part Number | Drawing | Figure |
|---|--------------------|--|---|
| 6 contacts module (Please order contacts separately) | | | |
| Pin module | C146 10A006 500 15 |  |  |
| Socket module | C146 10B006 500 15 |  |  |

| Supplied as | for wire gauge | AWG | Pieces | Part Number | | Figure |
|--|----------------------------|-----|--------|--------------------|--------------------|--|
| | | | | Male contact | Female contact | |
| Turned 2.5 mm crimp contacts single contact | | | | | | |
| silver plating | 0.5 mm ² | 20 | 100 | VN01 025 0035 (1)C | VN02 025 0035 (1)C |  |
| | 0.75 - 1.0 mm ² | 18 | 100 | VN01 025 0036 (1)C | VN02 025 0036 (1)C | |
| | 1.5 mm ² | 16 | 100 | VN01 025 0037 (1)C | VN02 025 0037 (1)C | |
| | 2.5 mm ² | 14 | 100 | VN01 025 0038 (1)C | VN02 025 0038 (1)C | |
| | 4.0 mm ² | 12 | 100 | VN01 025 0039 (1)C | VN02 025 0039 (1)C | |
| gold plating | 0.5 mm ² | 20 | 100 | VN01 025 0035 (2)C | VN02 025 0035 (2)C | |
| | 0.75 - 1.0 mm ² | 18 | 100 | VN01 025 0036 (2)C | VN02 025 0036 (2)C | |
| | 1.5 mm ² | 16 | 100 | VN01 025 0037 (2)C | VN02 025 0037 (2)C | |
| | 2.5 mm ² | 14 | 100 | VN01 025 0038 (2)C | VN02 025 0038 (2)C | |
| | 4.0 mm ² | 12 | 100 | VN01 025 0039 (2)C | VN02 025 0039 (2)C | |

Tools for turned contacts

| Description | for wire gauge | Part Number | | |
|--|--|--|----------------------------|--------------------|
| | | Contact locator | Crimping dies | Tool |
| Removal tool for contacts | | | | FG 0300 146 7 |
| Crimping tool for turned single contacts | 0.5 - 2.5 mm ² 4 mm ² | TA 0010 146 000 6 TA 0010 146 000 7 | TA 0000 144 TA 0000 124 | TA 0000 TA 0500 |
| 4-indent crimping tool for turned contacts | | | | TB 0600 146 |





Further tools see catalogue "Tools"

| General Characteristics | Standard | Value |
|-------------------------------------|-----------------|--|
| Number of contacts | | 8 |
| Termination technique | | crimp |
| Wire Gauge | | 0.5 – 4.0 mm ² (AWG 20-12) |
| Flammability | UL94 | V-0 |
| Electrical Characteristics | | |
| Rated voltage | IEC 60664-1 | 400 V |
| Pollution degree | IEC 60664-1 | 3 |
| Installation (overvoltage) category | IEC 60664-1 | III |
| Material group | IEC 60664-1 | II (PA) |
| Rated impulse withstand voltage | IEC 60664-1 | 6 kV |
| Current carrying capacity | IEC 60512-5-2 | see derating curves |
| Contact resistance | IEC 60512-2-1 | ≤ 5 mΩ |
| Insulation resistance | IEC 60512-3-1 | ≥ 10 ¹⁰ Ω |
| Climatical Characteristics | | |
| Climatic category | IEC 60068-1 | 40/125/21 |
| Upper temperature | IEC 60512-11-9 | +125°C |
| Lower temperature | IEC 60512-11-10 | -40°C |
| Mechanical Characteristics | | |
| Mechanical operation | IEC 60512-9-1 | ≥500 mating cycles |
| IP-degree of protection | IEC 60529 | IP00 (pin insert) / IP20 (socket insert) |
| Materials | | |
| Module | | PA6.6 GF |
| Colour module | | black |
| Contact | | CuZn (brass) |
| Contact plating | | Ag (silver) / Au (gold) |

Derating Curves

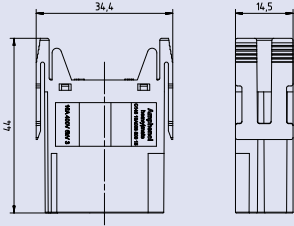
In preparation

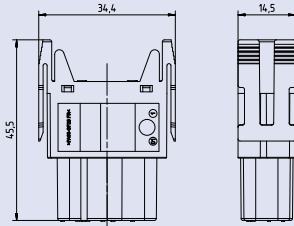
heavy|mate® F 8 contacts module + crimp contacts

| Description | Part Number | Drawing | Figure |
|---|--------------------|--|---|
| 38contacts module (Please order contacts separately) | | | |
| Pin module | C146 10A008 500 15 |  |  |
| Socket module | C146 10B008 500 15 |  |  |

| Supplied as | for wire gauge | AWG | Pieces | Part Number | | Figure |
|--|----------------------------|-----|--------|--------------------|--------------------|--|
| | | | | Male contact | Female contact | |
| Turned 2.5 mm crimp contacts single contact | | | | | | |
| silver plating | 0.5 mm ² | 20 | 100 | VN01 025 0035 (1)C | VN02 025 0035 (1)C |  |
| | 0.75 - 1.0 mm ² | 18 | 100 | VN01 025 0036 (1)C | VN02 025 0036 (1)C | |
| | 1.5 mm ² | 16 | 100 | VN01 025 0037 (1)C | VN02 025 0037 (1)C | |
| | 2.5 mm ² | 14 | 100 | VN01 025 0038 (1)C | VN02 025 0038 (1)C | |
| | 4.0 mm ² | 12 | 100 | VN01 025 0039 (1)C | VN02 025 0039 (1)C | |
| gold plating | 0.5 mm ² | 20 | 100 | VN01 025 0035 (2)C | VN02 025 0035 (2)C | |
| | 0.75 - 1.0 mm ² | 18 | 100 | VN01 025 0036 (2)C | VN02 025 0036 (2)C | |
| | 1.5 mm ² | 16 | 100 | VN01 025 0037 (2)C | VN02 025 0037 (2)C | |
| | 2.5 mm ² | 14 | 100 | VN01 025 0038 (2)C | VN02 025 0038 (2)C | |
| | 4.0 mm ² | 12 | 100 | VN01 025 0039 (2)C | VN02 025 0039 (2)C | |

Tools for turned contacts

| Description | for wire gauge | Part Number | | |
|--|--|--|----------------------------|--------------------|
| | | Contact locator | Crimping dies | Tool |
| Removal tool for contacts | | | | FG 0300 146 7 |
| Crimping tool for turned single contacts | 0.5 - 2.5 mm ² 4 mm ² | TA 0010 146 000 6 TA 0010 146 000 7 | TA 0000 144 TA 0000 124 | TA 0000 TA 0500 |
| 4-indent crimping tool for turned contacts | | | | TB 0600 146 |

Further tools see catalogue "Tools"

| General Characteristics | Standard | Value |
|-------------------------------------|-----------------|--|
| Number of contacts | | 12 |
| Termination technique | | crimp |
| Wire Gauge | | 0.14 – 2.5 mm ² (AWG 26-14) |
| Flammability | UL94 | V-0 |
| Electrical Characteristics | | |
| Rated voltage | IEC 60664-1 | 250 V (conductor – earth) 400 V (conductor – conductor) |
| Pollution degree | IEC 60664-1 | 3 |
| Installation (overvoltage) category | IEC 60664-1 | III |
| Material group | IEC 60664-1 | II (PA) |
| Rated impulse withstand voltage | IEC 60664-1 | 4 kV |
| Current carrying capacity | IEC 60512-5-2 | see derating curves |
| Contact resistance | IEC 60512-2-1 | ≤ 5 mΩ |
| Insulation resistance | IEC 60512-3-1 | ≥ 10 ¹⁰ Ω |
| Climatical Characteristics | | |
| Climatic category | IEC 60068-1 | 40/100/21 |
| Upper temperature | IEC 60512-11-9 | +100°C |
| Lower temperature | IEC 60512-11-10 | -40°C |
| Mechanical Characteristics | | |
| Mechanical operation | IEC 60512-9-1 | ≥500 mating cycles |
| IP-degree of protection | IEC 60529 | IP00 (pin insert) / IP20 (socket insert) |
| Materials | | |
| Module | | PA6.6 GF |
| Colour module | | black |
| Contact | | CuZn (brass) |
| Contact plating | | Ag (silver) / Au (gold) |

Derating Curves

In preparation

heavy|mate® F 12 contacts module + crimp contacts

| Description | Part Number | Drawing | Figure |
|--|--------------------|---------|--------|
| 12 contacts module (Please order contacts separately) | | | |
| Pin module | C146 10A012 500 15 | | |
| Socket module | C146 10B012 500 15 | | |

| Supplied as | for wire gauge | AWG | Pieces | Part Number | | Figure |
|---|-----------------------------|---------|--------|--------------------|--------------------|--------|
| | | | | Male contact | Female contact | |
| Turned crimp contacts single contact | | | | | | |
| silver plating | 0.14 - 0.37 mm ² | 26 - 22 | 100 | VN01 016 0024 (1)C | VN02 016 0024 (1)C | |
| | 0.5 mm ² | 20 | 100 | VN01 016 0025 (1)C | VN02 016 0025 (1)C | |
| | 0.75 - 1.0 mm ² | 20 - 16 | 100 | VN01 016 0026 (1)C | VN02 016 0026 (1)C | |
| | 1.5 mm ² | 16 - 15 | 100 | VN01 016 0027 (1)C | VN02 016 0027 (1)C | |
| | 2.5 mm ² | 14 | 100 | VN01 016 0028 (1)C | VN02 016 0028 (1)C | |
| gold plating | 0.14 - 0.37 mm ² | 26 - 22 | 100 | VN01 016 0024 (2)C | VN02 016 0024 (2)C | |
| | 0.5 mm ² | 20 | 100 | VN01 016 0025 (2)C | VN02 016 0025 (2)C | |
| | 0.75 - 1.0 mm ² | 20 - 16 | 100 | VN01 016 0026 (2)C | VN02 016 0026 (2)C | |
| | 1.5 mm ² | 16 - 15 | 100 | VN01 016 0027 (2)C | VN02 016 0027 (2)C | |
| | 2.5 mm ² | 14 | 100 | VN01 016 0028 (2)C | VN02 016 0028 (2)C | |

Tools for turned contacts

| Description | for wire gauge | Part Number | | |
|---------------------------|---|-----------------|---------------|---------------|
| | | Contact locator | Crimping dies | Tool |
| Removal tool for contacts | - | - | - | FG 0300 146 1 |
| Service crimping tool | 0.14 - 0.5 mm ² 0.5 - 1.5 mm ² | - | - | TA 0100 146 |





Further tools see catalogue "Tools"

| General Characteristics | Standard | Value |
|-------------------------------------|-----------------|--|
| Number of contacts | | 17 |
| Termination technique | | crimp |
| Wire Gauge | | 0.14 - 2.5mm ² (AWG 26-14) |
| Flammability | UL94 | V-0 |
| Electrical Characteristics | | |
| Rated voltage | IEC 60664-1 | 160 V |
| Pollution degree | IEC 60664-1 | 3 |
| Installation (overvoltage) category | IEC 60664-1 | III |
| Material group | IEC 60664-1 | II (PA) |
| Rated impulse withstand voltage | IEC 60664-1 | 2.5 kV |
| Current carrying capacity | IEC 60512-5-2 | see derating curves |
| Contact resistance | IEC 60512-2-1 | ≤ 5 mΩ |
| Insulation resistance | IEC 60512-3-1 | ≥ 10 ¹⁰ Ω |
| Climatical Characteristics | | |
| Climatic category | IEC 60068-1 | 40/100/21 |
| Upper temperature | IEC 60512-11-9 | +100°C |
| Lower temperature | IEC 60512-11-10 | -40°C |
| Mechanical Characteristics | | |
| Mechanical operation | IEC 60512-9-1 | ≥500 mating cycles |
| IP-degree of protection | IEC 60529 | IP00 (pin insert) / IP20 (socket insert) |
| Materials | | |
| Module | | PA6.6 GF |
| Colour module | | black |
| Contact | | CuZn (brass) |
| Contact plating | | Ag (silver) / Au (gold) |

Derating Curves

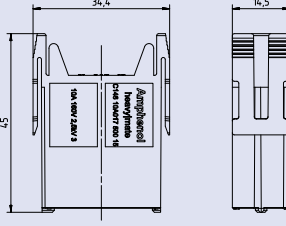
In preparation

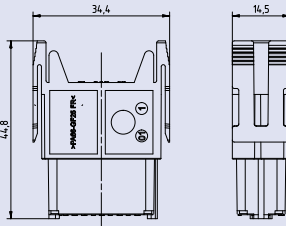
heavy|mate® F 17 contacts module + crimp contacts

| Description | Part Number | Drawing | Figure |
|--|--------------------|--|---|
| 17 contacts module (Please order contacts separately) | | | |
| Pin module | C146 10A017 500 15 |  |  |
| Socket module | C146 10B017 500 15 |  |  |

| Supplied as | for wire gauge | AWG | Pieces | Part Number | | Figure |
|---|-----------------------------|---------|--------|--------------------|--------------------|--|
| | | | | Male contact | Female contact | |
| Turned crimp contacts single contact | | | | | | |
| silver plating | 0.14 - 0.37 mm ² | 26 - 22 | 100 | VN01 016 0024 (1)C | VN02 016 0024 (1)C |  |
| | 0.5 mm ² | 20 | 100 | VN01 016 0025 (1)C | VN02 016 0025 (1)C | |
| | 0.75 - 1.0 mm ² | 20 - 16 | 100 | VN01 016 0026 (1)C | VN02 016 0026 (1)C | |
| | 1.5 mm ² | 16 - 15 | 100 | VN01 016 0027 (1)C | VN02 016 0027 (1)C | |
| | 2.5 mm ² | 14 | 100 | VN01 016 0028 (1)C | VN02 016 0028 (1)C | |
| gold plating | 0.14 - 0.37 mm ² | 26 - 22 | 100 | VN01 016 0024 (2)C | VN02 016 0024 (2)C | |
| | 0.5 mm ² | 20 | 100 | VN01 016 0025 (2)C | VN02 016 0025 (2)C | |
| | 0.75 - 1.0 mm ² | 20 - 16 | 100 | VN01 016 0026 (2)C | VN02 016 0026 (2)C | |
| | 1.5 mm ² | 16 - 15 | 100 | VN01 016 0027 (2)C | VN02 016 0027 (2)C | |
| | 2.5 mm ² | 14 | 100 | VN01 016 0028 (2)C | VN02 016 0028 (2)C | |

Tools for turned contacts

| Description | for wire gauge | Part Number | | |
|---------------------------|---|-----------------|---------------|---------------|
| | | Contact locator | Crimping dies | Tool |
| Removal tool for contacts | - | - | - | FG 0300 146 1 |
| Service crimping tool | 0.14 - 0.5 mm ² 0.5 - 1.5 mm ² | - | - | TA 0100 146 |





Further tools see catalogue "Tools"

| General Characteristics | Standard | Value |
|-------------------------------------|-----------------|--|
| Number of contacts | | 20 |
| Termination technique | | crimp |
| Wire Gauge | | 0.5 –4.0 mm ² (AWG 20-12) |
| Flammability | UL94 | V-0 |
| Electrical Characteristics | | |
| Rated voltage | IEC 60664-1 | 500 V |
| Pollution degree | IEC 60664-1 | 3 |
| Installation (overvoltage) category | IEC 60664-1 | III |
| Material group | IEC 60664-1 | II (PA) |
| Rated impulse withstand voltage | IEC 60664-1 | 6 kV |
| Current carrying capacity | IEC 60512-5-2 | see derating curves |
| Contact resistance | IEC 60512-2-1 | ≤ 5 mΩ |
| Insulation resistance | IEC 60512-3-1 | ≥ 10 ¹⁰ Ω |
| Climatical Characteristics | | |
| Climatic category | IEC 60068-1 | 40/125/21 |
| Upper temperature | IEC 60512-11-9 | +125°C |
| Lower temperature | IEC 60512-11-10 | -40°C |
| Mechanical Characteristics | | |
| Mechanical operation | IEC 60512-9-1 | ≥500 mating cycles |
| IP-degree of protection | IEC 60529 | IP00 (pin insert) / IP20 (socket insert) |
| Materials | | |
| Module | | PA6.6 GF |
| Colour module | | black |
| Contact | | CuZn (brass) |
| Contact plating | | Ag (silver) / Au (gold) |

Derating Curves

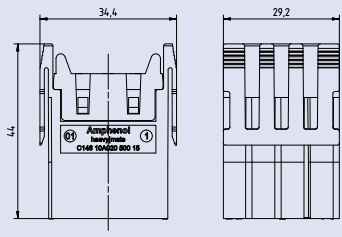
In preparation

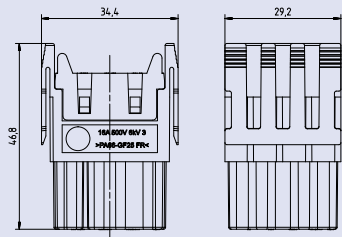
heavy|mate® F 20 contacts module + crimp contacts

| Description | Part Number | Drawing | Figure |
|--|--------------------|--|---|
| 20 contacts module (Please order contacts separately) | | | |
| Pin module | C146 10A020 500 15 |  |  |
| Socket module | C146 10B020 500 15 |  |  |

| Supplied as | for wire gauge | AWG | Pieces | Part Number | | Figure |
|--|----------------------------|-----|--------|--------------------|--------------------|--|
| | | | | Male contact | Female contact | |
| Turned 2.5 mm crimp contacts single contact | | | | | | |
| silver plating | 0.5 mm ² | 20 | 100 | VN01 025 0035 (1)C | VN02 025 0035 (1)C |  |
| | 0.75 - 1.0 mm ² | 18 | 100 | VN01 025 0036 (1)C | VN02 025 0036 (1)C | |
| | 1.5 mm ² | 16 | 100 | VN01 025 0037 (1)C | VN02 025 0037 (1)C | |
| | 2.5 mm ² | 14 | 100 | VN01 025 0038 (1)C | VN02 025 0038 (1)C | |
| | 4.0 mm ² | 12 | 100 | VN01 025 0039 (1)C | VN02 025 0039 (1)C | |
| gold plating | 0.5 mm ² | 20 | 100 | VN01 025 0035 (2)C | VN02 025 0035 (2)C | |
| | 0.75 - 1.0 mm ² | 18 | 100 | VN01 025 0036 (2)C | VN02 025 0036 (2)C | |
| | 1.5 mm ² | 16 | 100 | VN01 025 0037 (2)C | VN02 025 0037 (2)C | |
| | 2.5 mm ² | 14 | 100 | VN01 025 0038 (2)C | VN02 025 0038 (2)C | |
| | 4.0 mm ² | 12 | 100 | VN01 025 0039 (2)C | VN02 025 0039 (2)C | |

Tools for turned contacts

| Description | for wire gauge | Part Number | | |
|--|---------------------------|-------------------|---------------|---------------|
| | | Contact locator | Crimping dies | Tool |
| Removal tool for contacts | | | | FG 0300 146 7 |
| Crimping tool for turned single contacts | 0.5 - 2.5 mm ² | TA 0010 146 000 6 | TA 0000 144 | TA 0000 |
| | 4 mm ² | TA 0010 146 000 7 | TA 0000 124 | TA 0500 |
| 4-indent crimping tool for turned contacts | | | | TB 0600 146 |



Further tools see catalogue "Tools"

The image shows a large industrial testing chamber, likely a high-voltage test cell, in a factory or laboratory setting. The chamber is constructed from metal frames and glass panels, with blue-painted lower sections. A computer monitor is mounted on the front panel, displaying a software interface. To the right, a control panel with a keypad and a small screen is visible. The floor is made of perforated metal plates with yellow safety lines. The ceiling has exposed ductwork and lighting fixtures.

heavy | mate[®] HSE





- Rated voltage 400 V
- Rated current 42 A
- Termination: screw
- Number of contacts: 6

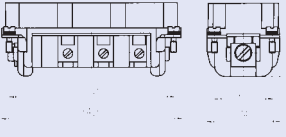

| Approvals, Testhouse | Characteristics | Approval-Number |
|--|-----------------|-----------------|
| UL  | 600 V, 35 A | 48932 |
| CSA  | 600 V, 35 A | E 63093 |

In general approvals refer to representative versions of the connector series. Extent and specification of tests upon request.

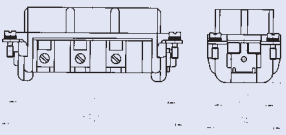
| General Characteristics | Standard | Value | |
|--|-----------------|---------------------------------------|------------|
| Number of contacts | | 6 + ⊕ | |
| Termination technique | | screw | |
| Wire gauge | | 0.5 - 6.0 mm ² (Ø 3.4 mm) | |
| Flammability | UL 94 | V-0 | |
| Electrical Characteristics | | | |
| Rated voltage | IEC 60664-1 | 400 V (600 V UL / CSA ¹⁾) | |
| Pollution degree | IEC 60664-1 | 3 | |
| Installation (overvoltage) category | IEC 60664-1 | III | |
| Material group | IEC 60664-1 | II | |
| Rated impulse withstand voltage | IEC 60664-1 | 6 kV | |
| Rated current | IEC 60512-5-2 | see derating curves | |
| Rated current T _{amp} = 40 °C | | 42 A | |
| Contact resistance | IEC 60512-2-1 | ≤ 1 m Ω | |
| Insulation resistance | IEC 60512-3-1 | ≥ 10 ¹⁰ Ω | |
| Climatical Characteristics | | | |
| Climatic category | IEC 60068-1 | 40 / 125 / 21 | |
| Upper temperature | IEC 60512-11-9 | + 125 °C | |
| Lower temperature | IEC 60512-11-10 | - 40 °C | |
| Mechanical Characteristics | | | |
| IP-degree of protection pin insert | IEC 60529 | unmated IP00 | mated IP20 |
| IP-degree of protection socket insert | IEC 60529 | unmated IP20 | mated IP20 |
| Weight pin insert | | 80 g | |
| Weight socket insert | | 80 g | |
| Mechanical operation | IEC 60512-9-1 | ≥ 500 mating cycles | |
| Werkstoffe | | | |
| Insert | | PA, GV | |
| Colour insert | | black | |
| Contacts | | Cu Zn (brass) | |
| Contact plating | | Ag (silver) | |

| Description | Part Number | Drawing | Figure |
|--|-------------------|--|---|
| Contact insert 6 + ⊕ | | | |
| Male insert with wire protection for screw termination | C146 10A006 102 5 |  |  |
| Female insert with wire protection for screw termination | C146 10B006 102 5 |  |  |

Pin layout

Male insert

Female insert

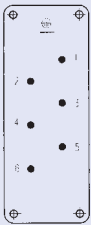

Assembly instruction

Panel cut out (insert)

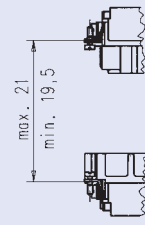
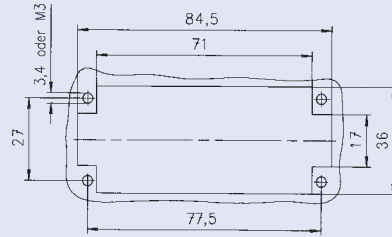

Derating curves

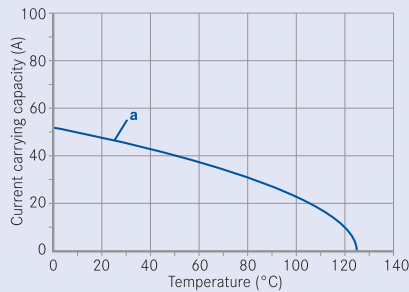



Curve a: 6 mm² screw contact



heavy | mate[®] HvE

- Rated voltage 660 V
- Rated current 16 A ... 22 A
- Termination: screw
- 2 delayed mating contacts
- Number of contacts: 3, 6, 10, 16, 20, 26, 32



| Approvals, Testhouse | Characteristics | Approval-Number |
|--|-----------------|-----------------|
| UL  | 600 V, 16 A | E 63093 |
| CSA  | 600 V, 16 A | 48932 |

In general approvals refer to representative versions of the connector series. Extent and specification of tests upon request.

Construction of connectors Type HVE

The connectors of series heavy|mate® HVE are based on series heavy|mate® E with the following deviations:

Inserts

The HVE-inserts with 3, 6 and 10 contacts are basically the same as the 10, 16 and 24-contacts inserts of series heavy|mate® E. However they are only partly loaded with contacts and have two delayed mating pilot duty contacts.

Only type 16 HVE has special inserts with a different contact arrangement. The mounting dimensions are however identical with the 24 contacts version of heavy|mate® E.

The delayed mating contacts are intended for switching a relay coil for electrically locking in order to have unloaded socket contacts in an unmated condition.

If connectors without breaking capacity are used as connectors with breaking capacity the electrical power data must be reduced in accordance with the manufacturer's specification. These specifications are available from the manufacturer.

heavy|mate® E inserts with pin contacts are not intermatable with heavy|mate® HVE inserts with socket contacts due to

- two empty contact holes are closed at 3, 6 and 10 contact inserts.
- the 16 contacts HVE insert has a different contact arrangement.

Housings: (made of aluminium)

heavy|mate® E housings with an inside insulation (plastic foil) are used for the 16-contacts insert.

The inside barriers at the narrow sides preventing mounting of 660 V-inserts in 400 V housings are removed and the 16-contacts insert is now mountable.

No standard for this series, but:

Intermatable and exchangeable with other makes

- Contact insert to contact insert
- Contact insert to housing 6, 10, 16, 24 pin

Housings are designed according to
DIN EN 175 301-801

First-to-mate last-to-break protective ground contact



heavy|mate® HVE Characteristics contact inserts

| General Characteristics | Standard | Value | | | | | | |
|---|-----------------|---|-------|-------|---------------|------------|------------------|-------|
| Number of contacts | | 3 | 6 | 10 | 16 | 20 | 26 ³⁾ | 32 |
| Termination technique | | screw | | | | | | |
| Wire gauge | | 0.25 - 2.5 mm ² | | | | | | |
| Flammability | UL 94 | V-0 | | | | | | |
| Electrical Characteristics | | | | | | | | |
| Rated voltage | IEC 60664-1 | 660 V ¹⁾ (600 V UL / CSA ²⁾) | | | | | | |
| Pollution degree | IEC 60664-1 | 3 | | | | | | |
| Installation (overvoltage) category | IEC 60664-1 | III | | | | | | |
| Material group | IEC 60664-1 | III a | II | IIIa | ³⁾ | II | | |
| Rated impulse withstand voltage | IEC 60664-1 | 8 kV | | | | | | |
| Current carrying capacity | IEC 60512-5-2 | see derating curves | | | | | | |
| Contact resistance | IEC 60512-2-1 | ≤ 5 m Ω | | | | | | |
| Insulation resistance | IEC 60512-3-1 | ≥ 10 ¹⁰ Ω | | | | | | |
| Climatical Characteristics | | | | | | | | |
| Climatic category | IEC 60068-1 | 40/125/21 | | | | | | |
| Upper temperature | IEC 60512-11-9 | + 125°C | | | | | | |
| Lower temperature | IEC 60512-11-10 | - 40°C | | | | | | |
| Mechanical Characteristics | | | | | | | | |
| IP-degree of protection pin insert ⁴⁾ | IEC 60529 | unmated IP00 | | | | mated IP20 | | |
| IP-degree of protection socket insert ⁴⁾ | IEC 60529 | unmated IP20 | | | | mated IP20 | | |
| Weight pin insert | | 49 g | 63 g | 81 g | 107 g | 162 g | 189 g | 214 g |
| Weight socket insert | | 49 g | 63 g | 81 g | 107 g | 162 g | 189 g | 214 g |
| Mechanical operation | IEC 60512-9-1 | ≥ 500 mating cycles | | | | | | |
| Materials | | | | | | | | |
| Insert | | PC, GV | PA,GV | PC,GV | ³⁾ | PA,GV | | |
| Colour insert | | grey | black | grey | ³⁾ | black | | |
| Contacts | | Cu Zn (brass) | | | | | | |
| Contact plating | | Ag (silver) | | | | | | |

| Description | Part Number | Drawing | Figure |
|---|-------------------|---------|--------|
| Contact insert 3 + ⊕ + 2 (delayed mating contacts) | | | |
| Male insert with wire protection for screw termination | C146 10A003 102 3 | | |
| Female insert with wire protection for screw termination | C146 10B003 102 3 | | |

| Pin layout | | Assembly instruction | |
|-------------|--|------------------------|--|
| Male insert | Female insert | Panel cut out (insert) | |
| | | | |
| | <ul style="list-style-type: none"> ● Working contact ◐ Mating contact ○ Without contact | | |



| Description | Part Number | Drawing | Figure |
|---|-------------------|---------|--------|
| Contact insert 6 + ⊕ + 2 (delayed mating contacts) | | | |
| Male insert with wire protection for screw termination | C146 10A006 102 3 | | |
| Female insert with wire protection for screw termination | C146 10B006 102 3 | | |

| Pin layout | | Assembly instruction | |
|--|---------------|------------------------|--|
| Male insert | Female insert | Panel cut out (insert) | |
| | | | |
| <ul style="list-style-type: none"> ● Working contact ◉ Mating contact ○ Without contact | | | |



| Description | Part Number | Drawing | Figure |
|--|-------------------|---------|--------|
| Contact insert 10 + ⊕ + 2 (delayed mating contacts) | | | |
| Male insert with wire protection for screw termination | C146 10A010 102 3 | | |
| Female insert with wire protection for screw termination | C146 10B010 102 3 | | |

| Pin layout | | Assembly instruction | |
|-------------|--|------------------------|--|
| Male insert | Female insert | Panel cut out (insert) | |
| | | | |
| | <ul style="list-style-type: none"> ● Working contact ○ Mating contact ○ Without contact | | |



| Description | Part Number | Drawing | Figure |
|---|-------------------|---------|--------|
| Contact insert 16 + \oplus2 (delayed mating contacts) | | | |
| Male insert with wire protection for screw termination | C146 10A016 102 3 | | |
| Male insert without wire protection for screw termination | C146 10A016 002 3 | | |
| Female insert with wire protection for screw termination | C146 10B016 102 3 | | |
| Female insert without wire protection for screw termination | C146 10B016 002 3 | | |

Pin layout

Male insert

Female insert

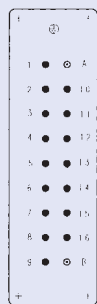
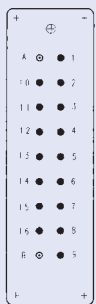

- Working contact
- Mating contact
- Without contact

Assembly instruction

Panel cut out (insert)

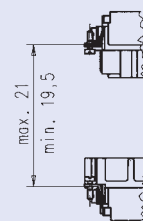
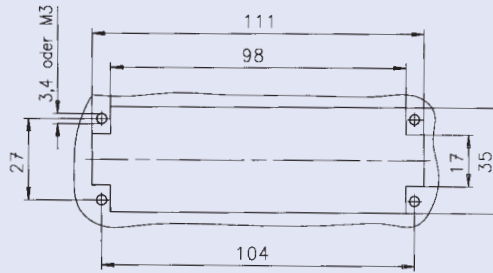

Derating curves

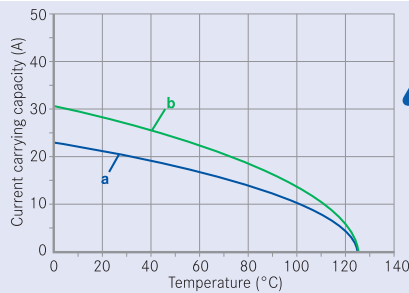

Notice restriction of wire

Curve a: 1.5 mm² screw contacts

Curve b: 2.5 mm² screw contacts



heavy | mate[®] K

- Power + signal as mixed arrangement
- Rated voltage up to 830 V
- Termination: screw, crimp



| Approvals, Testhouse | Characteristics | Approval-Number |
|--|-----------------|-----------------|
| UL  | In preparation | In preparation |
| CSA  | In preparation | In preparation |

heavy|mate® K Characteristics contact inserts 4/0 + 4 / 2

| General Characteristics | Standard | Value |
|-------------------------------------|-----------------|--|
| Number of contacts | | 4 / 0 (4 Power) 4 / 2 + PE (4 Power + 2 Signal) |
| Termination technique | | screw |
| Wire gauge | | 1.5 – 16 mm ² (AWG 16-6) |
| Flammability | UL94 | V-0 |
| Electrical Characteristics | | |
| Rated voltage | IEC 60664-1 | 830 V/400 V |
| Pollution degree | IEC 60664-1 | 3 |
| Installation (overvoltage) category | IEC 60664-1 | 3 |
| Material group | IEC 60664-1 | 3b |
| Rated impulse withstand voltage | IEC 60664-1 | 8.0 kV |
| Current carrying capacity | IEC 60512-5-2 | see derating curves |
| Contact resistance | IEC 60512-2-1 | ≤ 5 mΩ |
| Insulation resistance | IEC 60512-3-1 | ≥ 10 ¹⁰ Ω |
| Climatical Characteristics | | |
| Climatic category | IEC 60068-1 | 40/125/21 |
| Upper temperature | IEC 60512-11-9 | +125°C |
| Lower temperature | IEC 60512-11-10 | -40°C |
| Mechanical Characteristics | | |
| Mechanical operation | IEC 60512-9-1 | ≥500 mating cycles |
| Materials | | |
| Insert | | PC |
| Colour insert | | grey |
| Contacts | | Cu-alloy |
| Contact plating | | Ag (silver) |

Derating Curves

In preparation

| Description | Part Number | Drawing | Figure |
|---------------------------|--------------------|---------|--------|
| Contact insert 4/0 | | | |
| Male insert | C146 10A004 100 13 | | |
| Female insert | C146 10B004 100 13 | | |

Pin layout



| Description | Part Number | Drawing | Figure |
|------------------------------|--------------------|---------|--------|
| Contact insert 4+2+PE | | | |
| Male insert | C146 10A006 100 13 | | |
| Female insert | C146 10B006 100 13 | | |

Pin layout



heavy|mate® K Characteristics contact inserts 6 / 36 + PE

| General Characteristics | Standard | Value |
|-------------------------------------|-----------------|---|
| Number of contacts | | 6/36 + PE |
| Termination technique | | crimp |
| Wire gauge | | 1.5 – 6.0mm ² (AWG 16-10) 0.14 – 2.5mm ² (AWG 26-14) |
| Flammability | UL94 | V-0 |
| Electrical Characteristics | | |
| Rated voltage | IEC 60664-1 | 690 / 160V |
| Pollution degree | IEC 60664-1 | 3 |
| Installation (overvoltage) category | IEC 60664-1 | 3 |
| Material group | IEC 60664-1 | 3b |
| Rated impulse withstand voltage | IEC 60664-1 | 8.0 / 2.5 kV |
| Current carrying capacity | IEC 60512-5-2 | see derating curves |
| Contact resistance | IEC 60512-2-1 | ≤ 5 mΩ |
| Insulation resistance | IEC 60512-3-1 | ≥ 10 ¹⁰ Ω |
| Climatical Characteristics | | |
| Climatic category | IEC 60068-1 | 40 / 125 / 21 |
| Upper temperature | IEC 60512-11-9 | 125°C |
| Lower temperature | IEC 60512-11-10 | -40°C |
| Mechanical Characteristics | | |
| Mechanical operation | IEC 60512-9-1 | ≥500 mating cycles |
| Materials | | |
| Insert | | PC |
| Colour insert | | grey |
| Contacts | | Cu-alloy |
| Contact plating | | Ag (silver) /Au (gold) |

Derating Curves

In preparation

| Description | Part Number | Drawing | Figure |
|--|--------------------|---------|--------|
| Contact insert 6 / 36 + PE (Please order contacts separately) | | | |
| Male insert | C146 10A042 500 13 | | |
| Female insert | C146 10B042 500 13 | | |

Pin layout

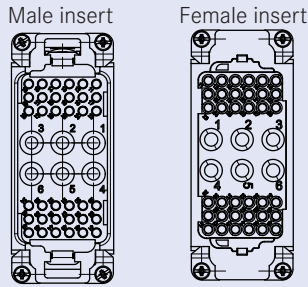

| Supplied as | for wire gauge | AWG | Pieces | Part Number | | Figure |
|--|-----------------------------|-------|--------|------------------|------------------|--------|
| | | | | Male contact | Female contact | |
| Turned 4 mm crimp contacts single contact | | | | | | |
| silver plating | 1.5 mm ² | 16 | 100 | VN01 040 0010 1C | VN02 040 0010 1C | |
| | 2.5 mm ² | 14 | 100 | VN01 040 0011 1C | VN02 040 0011 1C | |
| | 4 mm ² | 12 | 100 | VN01 040 0012 1C | VN02 040 0012 1C | |
| | 6 mm ² | 10 | 100 | VN01 040 0013 1C | VN02 040 0013 1C | |
| Turned 1.6 mm crimp contacts single contact | | | | | | |
| silver plating | 0.14 - 0.37 mm ² | 26-22 | 100 | VN01 016 0024 1C | VN02 016 0024 1C | |
| | 0.5 mm ² | 20 | 100 | VN01 016 0025 1C | VN02 016 0025 1C | |
| | 0.75 - 1.0 mm ² | 20-16 | 100 | VN01 016 0026 1C | VN02 016 0026 1C | |
| | 1.5 mm ² | 16-15 | 100 | VN01 016 0027 1C | VN02 016 0027 1C | |
| | 2.5 mm ² | 14 | 100 | VN01 016 0028 1C | VN02 016 0028 1C | |



heavy | mate[®] M

- Modular connector
- More module slots than heavy | mate[®] F and market standard
- Rated voltage 63 - 1000 V
- Rated current 5 A ... 250 A
- Termination: crimp



| Approvals, Testhouse | Characteristics | Approval-Number |
|--|--|-----------------|
| VDE  | Characteristics see rated voltage and rated current of each module | 56 79 ÜG |
| SEV  | | |
| UL  | | E 63093 |
| CSA  | | 48932 |

In general approvals refer to representative versions of the connector series. Extent and specification of tests upon request.

General information

- Modules inserts without crimp contacts, crimping tools see separate catalogue "Tools".
- Contacts must be ordered separately, processing instructions see catalogue "Tools".
- Connectors series heavy|mate® M may be engaged or disengaged when live but without electrical load. If these connectors are mated or unmated under load, the load shall be reduced to 10 % of rated current.

- We recommend using the high profile housings / hoods for the heavy|mate® M inserts.
- Empty modul spaces have to be filled with blind modules.
- Torque for PE connection 1.8 Nm



Advantages of the system

- High combination possibilities
- Possibility of inverse configuration
- Rated voltage up to 1000 V
- Low cost

First-to-mate last-to-break protective ground contact

Minimum wire size 0.5 mm²



Modules



Frames

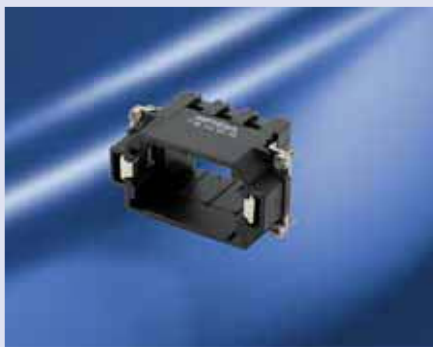

Range of housings



Requirements

- 3 x 400V; 50A; 6mm² wire gauge
- 8 x 250V; 8A; 1.5mm² wire gauge
- 5 x 400V; 15A; 4mm² wire gauge

Solution

1. Check how 16 contacts can be realized; see modules overview on page 118

Possible selection:

- a) 1 x 20 contacts
- b) 2 x 10 contacts
- c) 1 x 10 contacts+ 1 x 5 contacts
- d) 1 x 3 contacts + 1 x 5 contacts + 1 x 10 contacts

2. Check technical parameters / solution, see detail pages of the modules on page 126

Possible selection:

- a) not possible due to voltage
- b) not possible due to voltage
- c) not possible due to current
- d) POSSIBLE

3. Choose matching contact, see detail page of the modules on page 126

Possible selection:

- a) 3 contacts = C146 A03 001 E8 → contacts = VN01 036 0002 1C
- b) 5 contacts = C146 A05 001 E8 → contacts = VN01 025 0033 1C
- c) 10 contacts = C146 A10 001 E8 → contacts = VN01 016 0027 1XC

4. Choose matching frame, see frames on page 124

Solution: C146 P10 001 G8

5. Choose matching housing, see housings from page 162

Solution: C146 21R010 600 8

Schematic construction

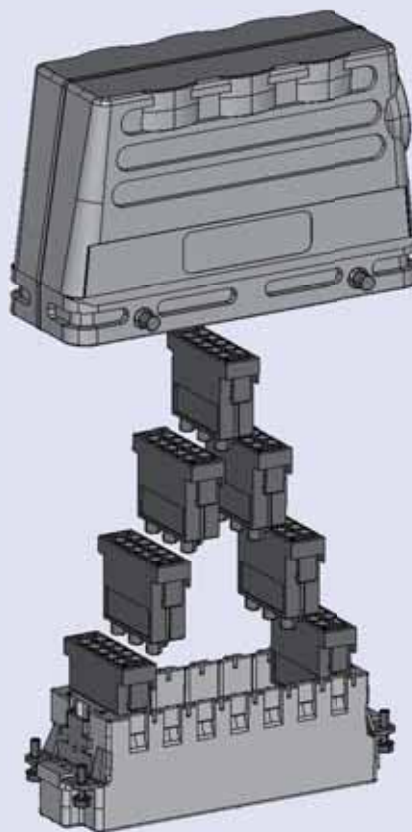







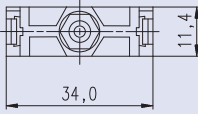

| Description | Part Number | Drawing | Figure |
|---|-----------------|---------|--------|
| 1 contact, Details see page 126 | | | |
| Pin Module | C146 A01 001 E8 | | |
| Socket Module | C146 B01 004 E1 | | |
| 2 contacts for turned contacts, Details see page 128 | | | |
| Pin Module | C146 A02 001 E8 | | |
| Socket Module | C146 B02 001 E8 | | |
| 2 contacts Powermodule, Details see page 130 | | | |
| Pin Module | C146 A02 801 E8 | | |
| Socket Module | C146 B02 801 E8 | | |

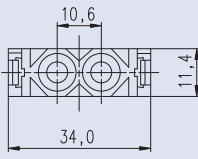

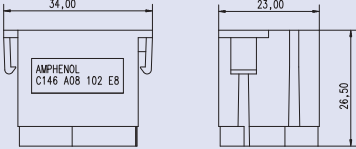

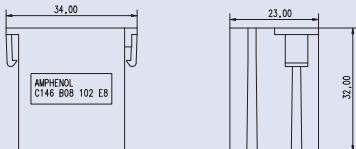
| Description | Part Number | Drawing | Figure |
|--|--|---|---|
| 3 contacts for turned contacts, 1000 V, Details see page 132 | | | |
| Pin Module | C146 A03 801 E8 |  |  |
| Socket Module | C146 B03 801 E8 |  |  |
| 3 contacts for turned contacts, 690 V, Details see page 134 | | | |
| Pin Module | C146 A03 001 E8 |  |  |
| Socket Module | C146 B03 001 E8 |  |  |
| 5 contacts for stamped contacts, 1000 V, Details see page 136 | | | |
| Pin Module | C146 D04 001 E8 (4 pol) C146 D05 001 E8 (4 + PE) C146 D05 801 E8 (5 pol) |  |  |
| Socket Module | C146 C04 001 E8 (4 pol) C146 C05 001 E8 (4 + PE) C146 C05 801 E8 (5 pol) |  |  |

| Description | Part Number | Drawing | Figure |
|--|-----------------|--|---|
| 5 contacts for turned contacts, 400 V, Details see page 138 | | | |
| Pin Module | C146 A05 001 E8 |  |  |
| Socket Module | C146 B05 001 E8 |  |  |
| 10 contacts for stamped contacts, 400 V, Details see page 140 | | | |
| Pin Module | C146 D10 001 E8 |  |  |
| Socket Module | C146 C10 001 G8 |  |  |
| 10 contacts for turned contacts, 400 V, Details see page 142 | | | |
| Pin Module | C146 A10 001 E8 |  |  |
| Socket Module | C146 B10 001 E8 |  |  |

| Description | Part Number | Drawing | Figure |
|--|-----------------|--|---|
| 20 contacts for stamped contacts, 100 V, Details see page 144 | | | |
| Pin Module | C146 A20 001 G8 |  |  |
| Socket Module | C146 B20 001 G8 |  |  |
| 3 contacts for coax contacts, Details see page 146 | | | |
| Pin Module | C146 A03 501 E8 |  |  |
| Socket Module | C146 B20 001 G8 |  |  |
| RJ module, 400 V, Details see page 148 | | | |
| Pin Module | C146 E12 001 E8 |  |  |
| Socket Module | C146 F12 001 G8 |  |  |

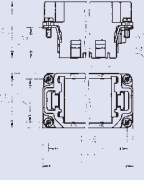
| Description | Part Number | Drawing | Figure |
|---|--|--|---|
| Pneumatic module, 1 or 2 connections, Details see page 150 | | | |
| Pin Module | C146 G01 014 G8 (2.5 mm) C146 G01 024 G8 (4.0 mm) C146 G02 014 G8 (2.5 mm) C146 G02 024 G8 (4.0 mm) |  |  |
| Socket Module | C146 H01 034 G8 (2.5 mm) C146 H01 044 G8 (4.0 mm) C146 H02 034 G8 (2.5 mm) C146 H02 044 G8 (4.0 mm) |  |  |
| Shielded module 2x4 contacts for bus signals, 50 V, Details see page 152 | | | |
| Pin Module | C146 A08 102 E8 C146 A05 100 G8 |  |  |
| Socket Module | C146 B08 102 E8 C146 B05 100 G8 |  |  |

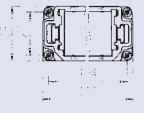
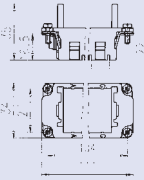
| Description | Part Number | Drawing | Figure |
|--------------------------------------|--|---|---|
| Frame for 2 modules Size 6 | | | |
| Frame for pin modules | C146 P06 001 G8 C146 P06 002 G8 (2 x PE) |  |  |
| Frame for socket modules | C146 S06 001 G8 C146 S06 002 G8 (2 x PE) |  |  |
| Frame for 3 modules Size 10 | | | |
| Frame for pin modules | C146 P10 001 G8 C146 P10 002 G8 (2 x PE) |  |  |
| Frame for socket modules | C146 S10 001 G8 C146 S10 002 G8 (2 x PE) |  |  |
| Frame for 5 modules Size 16 | | | |
| Frame for pin modules | C146 P16 001 G8 C146 P16 002 G8 (2 x PE) |  |  |
| Frame for socket modules | C146 S16 001 G8 C146 S16 002 G8 (2 x PE) |  |  |

| Description | Part Number | Drawing | Figure |
|--------------------------------------|--|---|---|
| Frame for 7 modules Size 24 | | | |
| Frame for pin modules | C146 P24 001 G8 C146 P24 002 G8 (2 x PE) |  |  |
| Frame for pin modules | C146 P24 101 G8 C146 P24 102 G8 (2 x PE) |  | |
| Frame for socket modules | C146 S24 001 G8 C146 S24 002 G8 (2 x PE) |  |  |
| Frame for socket modules | C146 S24 101 G8 C146 S24 102 G8 (2 x PE) |  | |

heavy|mate[®] M Characteristics 1 contact module

| General Characteristics | Standard | Value |
|-------------------------------------|-----------------|---|
| Number of contacts | | 1 |
| Termination technique | | crimp |
| Wire gauge | | 50 / 70 / 95 mm ² (AWG 1/00/000) |
| Flammability | UL94 | V-0 |
| Electrical Characteristics | | |
| Rated voltage | IEC 60664-1 | 1000 V |
| Pollution degree | IEC 60664-1 | 3 |
| Installation (overvoltage) category | IEC 60664-1 | 3 |
| Material group | IEC 60664-1 | 2 |
| Rated impulse withstand voltage | IEC 60664-1 | 8.0 kV |
| Current carrying capacity | IEC 60512-5-2 | see derating curves |
| Contact resistance | IEC 60512-2-1 | ≤ 1 mΩ |
| Insulation resistance | IEC 60512-3-1 | ≥ 10 ¹⁰ Ω |
| Climatical Characteristics | | |
| Climatic category | IEC 60068-1 | 40 / 125 / 21 |
| Upper temperature | IEC 60512-11-9 | 125°C |
| Lower temperature | IEC 60512-11-10 | -40°C |
| Mechanical Characteristics | | |
| IP-degree of protection | IEC 60529 | 20 |
| Mechanical operation | IEC 60512-9-1 | ≥ 500 mating cycles |
| Materials | | |
| Module | | PA 6.6 GF |
| Colour module | | black |
| Contacts | | Cu-alloy |
| Contact plating | | Ag (silver) |

Derating Curves

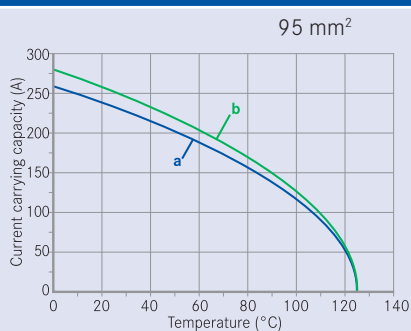

| Curve | Frame |
|-------|-----------|
| a | 3 Modules |
| b | 1 Modules |

heavy|mate® M 1 contact module + crimp contacts

| Description | Part Number | Drawing | Figure |
|--|-----------------|--|---|
| 1 contact module (Please order contacts separately) | | | |
| Pin module | C146 A01 001 E8 |  |  |
| Socket module | C146 B01 004 E8 |  |  |

| Supplied as | for wire gauge | AWG | Pieces | Part Number | | Figure |
|------------------------------------|--------------------|-----|--------|------------------|------------------|--|
| | | | | Male contact | Female contact | |
| Turned 10 mm crimp contacts | | | | | | |
| Single contact | 50 mm ² | 1 | 1 | N01 100 6001 001 | N02 100 6121 002 |  |
| | 70 mm ² | 00 | 1 | N01 100 6002 001 | N02 100 6122 002 | |
| | 95 mm ² | 000 | 1 | N01 100 6003 001 | N02 100 6123 002 | |

| Tools | | | | |
|---------------|--------------------|-----------------|---------------|------|
| Description | for wire gauge | Part Number | | |
| | | Contact locator | Crimping dies | Tool |
| Crimping dies | 50 mm ² | | TE 0500 103 | |
| | 70 mm ² | | TE 0500 201 | |
| | 95 mm ² | | TE 0500 301 | |

For use in pneumatic crimping tool EK12042 by Klauke or AHPW 400C by Neko .
Further tools see catalogue "Tools"

heavy|mate[®] M Characteristics 2 contacts Radsok module for turned contacts

| General Characteristics | Standard | Value |
|-------------------------------------|-----------------|--|
| Number of contacts | | 2 |
| Termination technique | | crimp |
| Wire gauge | | 16 / 25 / 35 mm ² (AWG 6/4/2) |
| Flammability | UL94 | V-0 |
| Electrical Characteristics | | |
| Rated voltage | IEC 60664-1 | 1000 V |
| Pollution degree | IEC 60664-1 | 3 |
| Installation (overvoltage) category | IEC 60664-1 | 3 |
| Material group | IEC 60664-1 | 2 |
| Rated impulse withstand voltage | IEC 60664-1 | 8.0 kV |
| Current carrying capacity | IEC 60512-5-2 | see derating curves |
| Contact resistance | IEC 60512-2-1 | ≤ 1 mΩ |
| Insulation resistance | IEC 60512-3-1 | ≥ 10 ¹⁰ Ω |
| Climatical Characteristics | | |
| Climatic category | IEC 60068-1 | 40 / 125 / 21 |
| Upper temperature | IEC 60512-11-9 | 125°C |
| Lower temperature | IEC 60512-11-10 | -40°C |
| Mechanical Characteristics | | |
| IP-degree of protection | IEC 60529 | 20 |
| Mechanical operation | IEC 60512-9-1 | ≥ 500 mating cycles |
| Materials | | |
| Module | | PA 6.6 GF |
| Colour module | | black |
| Contacts | | Cu-alloy |
| Contact plating | | Ag (silver) |

Derating Curves

16 mm² / 25 mm² / 35 mm²

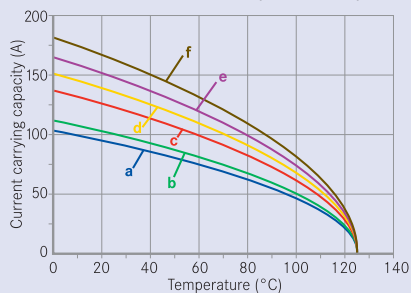

| Curve | Frame |
|-------|-------------------------------|
| a | 6 contacts 16 mm ² |
| b | 2 contacts 16 mm ² |
| c | 6 contacts 25 mm ² |
| d | 2 contacts 25 mm ² |
| e | 6 contacts 35 mm ² |
| f | 2 contacts 35 mm ² |

heavy|mate[®] M 2 contacts Radsok module + crimp contacts

| Description | Part Number | Drawing | Figure |
|---|-----------------|---------|--------|
| 2 contacts module for turned contacts (Please order contacts separately) | | | |
| Pin module | C146 A02 001 E8 | | |
| Socket module | C146 B02 001 E8 | | |

| Supplied as | for wire gauge | AWG | Pieces | Part Number | | Figure |
|---------------------------------------|--------------------|-----|--------|------------------|------------------|--------|
| | | | | Male contact | Female contact | |
| Turned 6 mm crimp contacts | | | | | | |
| Single contact | 16 mm ² | 6 | 1 | N01 060 0007 1 | N02 060 6117 001 | |
| | 25 mm ² | 4 | | N01 060 0004 1 | N02 060 6114 001 | |
| | 35 mm ² | 2 | | N01 060 0008 1 | N02 060 6118 001 | |
| Cable lug for earth connection | | | | | | |
| Single contact | 16 mm ² | 6 | 1 | N15 043 0003 003 | | |

| Tools | | | | | |
|-------------------------------------|--------------------|-----------------|---------------|---|------|
| Description | for wire gauge | Part Number | | | Tool |
| | | Contact locator | Crimping dies | | |
| Crimping dies | 16 mm ² | - | TE 0600 062 | - | |
| | 25 mm ² | - | TE 0600 042 | - | |
| | 35 mm ² | - | TE 0600 022 | - | |
| Further tools see catalogue "Tools" | | | | | |

heavy|mate[®] M Characteristics 2 contacts Powermodule

| General Characteristics | Standard | Value |
|-------------------------------------|-----------------|----------------------------|
| Number of contacts | | 2 |
| Termination technique | | crimp |
| Wire gauge | | 16 mm ² (AWG 6) |
| Flammability | UL94 | V-0 |
| Electrical Characteristics | | |
| Rated voltage | IEC 60664-1 | 1000 V |
| Pollution degree | IEC 60664-1 | 3 |
| Installation (overvoltage) category | IEC 60664-1 | 3 |
| Material group | IEC 60664-1 | 2 |
| Rated impulse withstand voltage | IEC 60664-1 | 8.0 kV |
| Current carrying capacity | IEC 60512-5-2 | see derating curves |
| Contact resistance | IEC 60512-2-1 | ≤ 1 mΩ |
| Insulation resistance | IEC 60512-3-1 | ≥ 10 ¹⁰ Ω |
| Climatical Characteristics | | |
| Climatic category | IEC 60068-1 | 40 / 125 / 21 |
| Upper temperature | IEC 60512-11-9 | 125 °C |
| Lower temperature | IEC 60512-11-10 | -40 °C |
| Mechanical Characteristics | | |
| IP-degree of protection | IEC 60512-9-1 | ≥ 500 Steckzyklen |
| Mechanical operation | IEC 60529 | 20 |
| Materials | | |
| Module | | PA 6.6 GF |
| Colour module | | black |
| Contacts | | Cu-alloy |
| Contact plating | | Ag (silver) |

Derating Curves

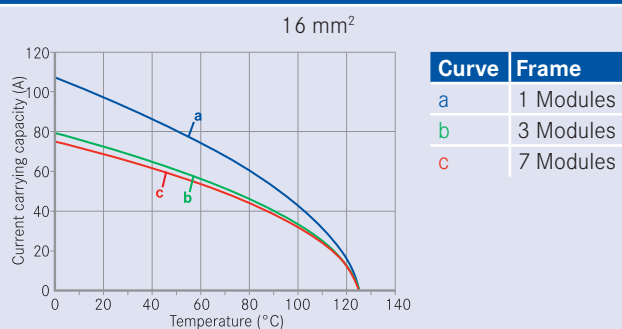

General requirements

- Due to reduced cross sections at PE contacts of frames, the PE contact has to be additionally protected against short circuits by using a protection circuit offering a sufficiently short breaking time (<0.25s).
- Parts to be used as connectors, not as plug devices (connector with breaking capacity). Do not mate under current or voltage!

heavy|mate® M 2 contacts Powermodule + crimp contacts

| Description | Part Number | Drawing | Figure |
|---|-----------------|---------|--------|
| 2 contacts module (Please order contacts separately) | | | |
| Pin module | C146 A02 801 E8 | | |
| Socket module | C146 B02 801 E8 | | |

| Supplied as | for wire gauge | AWG | Pieces | Part Number | | Figure |
|---------------------------------------|--------------------|-----|--------|-------------------|------------------|--------|
| | | | | Male contact | Female contact | |
| Turned 3.6 mm crimp contacts | | | | | | |
| Single contact | 16 mm ² | 6 | 100 | VN01 036 0021 1C | VN02 036 0021 1C | |
| Cable lug for earth connection | | | | | | |
| Single contact | 16 mm ² | 6 | 1 | N 15 043 0003 003 | | |

| Tools | | | | |
|-------------------------------------|--------------------|-----------------|---------------|---------------------------|
| Description | for wire gauge | Part Number | | |
| | | Contact locator | Crimping dies | Tool |
| Crimping dies | 16 mm ² | - | - | TE 0600 063 ¹⁾ |
| Removal tool for contacts | | - | - | FG 0300 146 3 |
| Removal tool for modules | | - | - | FG 1000 146 |
| Further tools see catalogue "Tools" | | | | |

| General Characteristics | Standard | Value |
|-------------------------------------|-----------------|---------------------------------------|
| Number of contacts | | 3 |
| Termination technique | | crimp |
| Wire gauge | | 1.5 - 10 mm ² (AWG 16 - 8) |
| Flammability | UL 94 | V-0 |
| Electrical Characteristics | | |
| Rated voltage | IEC 60664-1 | 1000 V ¹⁾ |
| Pollution degree | IEC 60664-1 | 3 |
| Installation (overvoltage) category | IEC 60664-1 | III |
| Material group | IEC 60664-1 | II |
| Rated impulse withstand voltage | IEC 60664-1 | 8.0 kV |
| Current carrying capacity | IEC 60512-5-2 | see derating curves |
| Contact resistance | IEC 60512-2-1 | ≤ 1 mΩ |
| Insulation resistance | IEC 60512-3-1 | ≥ 10 ¹⁰ Ω |
| Climatical Characteristics | | |
| Climatic category | IEC 60068-1 | 40 / 125 / 21 |
| Upper temperature | IEC 60512-11-9 | + 125 °C |
| Lower temperature | IEC 60512-11-10 | - 40 °C |
| Mechanical Characteristics | | |
| IP-degree of protection | IEC 60529 | 20 |
| Mechanical operation | IEC 60512-9-1 | ≥ 500 mating cycles |
| Materials | | |
| Module | | PA 6.6 GF |
| Colour module | | black |
| Contacts | | Cu-alloy |
| Contact plating | | Ag (silver) |

Derating Curves



| Curve | Frame |
|-------|-----------|
| a | 7 Modules |
| b | 3 Modules |
| c | 2 Modules |
| d | 1 Modules |



| Curve | Frame |
|-------|-----------|
| a | 7 Modules |
| b | 3 Modules |
| c | 2 Modules |
| d | 1 Modules |



| Curve | Frame |
|-------|-----------|
| a | 7 Modules |
| b | 3 Modules |
| c | 1 Modules |



| Curve | Frame |
|-------|-------------|
| a | 5-7 Modules |
| b | 3 Modules |
| c | 2 Modules |
| d | 1 Modules |



| Curve | Frame |
|-------|-------------|
| a | 3-7 Modules |
| b | 2 Modules |
| c | 1 Modules |

heavy|mate® M 3 contacts module + crimp contacts

| Description | Part Number | Drawing | Figure |
|---|-----------------|--|---|
| 3 contacts module (Please order contacts separately) | | | |
| Pin module | C146 A03 801 E8 |  |  |
| Socket module | C146 B03 801 E8 |  |  |

| Supplied as | for wire gauge | AWG | Pieces | Part Number | | Figure |
|---|----------------------|-----|--------|----------------------------------|----------------------------------|--|
| | | | | Male contact | Female contact | |
| Turned 3.6 mm crimp contacts (All contacts 2mm first-to-mate to other modules) | | | | | | |
| | 1.5 mm ² | 16 | 100 | VN01 036 0004 (1)C | VN02 036 0004 (1)C |  |
| | 2.5 mm ² | 14 | 100 | VN01 036 0005 (1)C | VN02 036 0005 (1)C | |
| | 4.0 mm ² | 12 | 100 | VN01 036 0001 (1)C | VN02 036 0001 (1)C | |
| | 6.0 mm ² | 10 | 100 | VN01 036 0002 (1)C ¹⁾ | VN02 036 0002 (1)C ¹⁾ | |
| | 10.0 mm ² | 8 | 100 | VN01 036 0003 (1)C ¹⁾ | VN02 036 0003 (1)C ¹⁾ | |

| Tools | | | | | |
|-------------------------------------|---------------------------|-------------------|---------------|---------------|--------------------|
| Description | for wire gauge | Part Number | | | Tool |
| | | Contact locator | Crimping dies | | |
| Removal tool for contacts | - | - | - | - | FG 0300 146 3 |
| Removal tool for modules | - | - | - | - | FG 1000 146 |
| Crimping tool for single contacts | 1.5 - 2.5 mm ² | TA 0010 146 000 2 | TA 0000 144 | | TA 0000 |
| | 4.0 mm ² | TA 0010 146 000 4 | TA 0000 124 | | |
| | 6.0 mm ² | TA 0010 146 000 4 | TA 0000 124 | | |
| 4-ondet crimping tool ²⁾ | 1.5 -10.0 mm ² | - | - | - | TB 0200 146 |
| Crimping tool for cable lugs | 6.0 mm ² | - | TA 0000 180 | | TA 0000 |
| | 10.0 mm ² | - | | | |
| Cable lugs for PE connection | | | | Pieces | Part Number |
| Cable lug | 6.0 mm ² | - | 20 | | N15 006 000 9Z |
| | 10.0 mm ² | - | 20 | | N15 010 000 7Z |
| Further tools see catalogue "Tools" | | | | | |

| General Characteristics | Standard | Value |
|-------------------------------------|-----------------|---------------------------------------|
| Number of contacts | | 3 |
| Termination technique | | crimp |
| Wire gauge | | 1.5 - 10 mm ² (AWG 16 - 8) |
| Flammability | UL 94 | V-0 |
| Electrical Characteristics | | |
| Rated voltage | IEC 60664-1 | 630 V |
| Pollution degree | IEC 60664-1 | 3 |
| Installation (overvoltage) category | IEC 60664-1 | III |
| Material group | IEC 60664-1 | II (PA) |
| Rated impulse withstand voltage | IEC 60664-1 | 8.0 kV |
| Current carrying capacity | IEC 60512-5-2 | see derating curves |
| Contact resistance | IEC 60512-2-1 | ≤ 1 mΩ |
| Insulation resistance | IEC 60512-3-1 | ≥ 10 ¹⁰ Ω |
| Climatical Characteristics | | |
| Climatic category | IEC 60068-1 | 40 / 125 / 21 |
| Upper temperature | IEC 60512-11-9 | + 125 °C |
| Lower temperature | IEC 60512-11-10 | - 40 °C |
| Mechanical Characteristics | | |
| Mechanical operation | IEC 60512-9-1 | ≥ 500 mating cycles |
| Materials | | |
| Module | | PA 6.6 GF |
| Colour module | | black |
| Contacts | | Cu-alloy |
| Contact plating | | Ag (silver) |

Derating Curves



| Curve | Frame |
|-------|-----------|
| a | 7 Modules |
| b | 3 Modules |
| c | 2 Modules |
| d | 1 Modules |



| Curve | Frame |
|-------|-----------|
| a | 7 Modules |
| b | 3 Modules |
| c | 2 Modules |
| d | 1 Modules |



| Curve | Frame |
|-------|-----------|
| a | 7 Modules |
| b | 3 Modules |
| c | 1 Modules |



| Curve | Frame |
|-------|-------------|
| a | 5-7 Modules |
| b | 3 Modules |
| c | 2 Modules |
| d | 1 Modules |



| Curve | Frame |
|-------|-------------|
| a | 3-7 Modules |
| b | 2 Modules |
| c | 1 Modules |

heavy|mate® M 3 contacts module + crimp contacts

| Description | Part Number | Drawing | Figure |
|---|-----------------|--|---|
| 3 contacts module (Please order contacts separately) | | | |
| Pin module | C146 A03 001 E8 |  |  |
| Socket module | C146 B03 001 E8 |  |  |

| Supplied as | for wire gauge | AWG | Pieces | Part Number | | Figure |
|--|----------------------|-----|--------|----------------------------------|----------------------------------|--|
| | | | | Male contact | Female contact | |
| Turned 3.6 mm crimp contacts single contact | | | | | | |
| silver plating | 1.5 mm ² | 16 | 100 | VN01 036 0004 (1)C | VN02 036 0004 (1)C |  |
| | 2.5 mm ² | 14 | 100 | VN01 036 0005 (1)C | VN02 036 0005 (1)C | |
| | 4.0 mm ² | 12 | 100 | VN01 036 0001 (1)C | VN02 036 0001 (1)C | |
| | 6.0 mm ² | 10 | 100 | VN01 036 0002 (1)C ¹⁾ | VN02 036 0002 (1)C ¹⁾ | |
| | 10.0 mm ² | 8 | 100 | VN01 036 0003 (1)C ¹⁾ | VN02 036 0003 (1)C ¹⁾ | |

| Tools | | | | | |
|--------------------------------------|---------------------------|-------------------|---------------|----------------|--------------------|
| Description | for wire gauge | Part Number | | | Tool |
| | | Contact locator | Crimping dies | | |
| Removal tool for contacts | - | - | - | - | FG 0300 146 3 |
| Removal tool for modules | - | - | - | - | FG 1000 146 |
| Crimping tool for single contacts | 1.5 - 2.5 mm ² | TA 0010 146 000 5 | TA 0000 144 | TA 0000 | TA 0000 |
| | 4.0 mm ² | TA 0010 146 000 4 | TA 0000 124 | | |
| | 6.0 mm ² | TA 0010 146 000 4 | TA 0000 124 | | |
| 4-indent crimping tool ²⁾ | 1.5 -10.0 mm ² | - | - | - | TB 0200 146 |
| Crimping tool for cable lugs | 6.0 mm ² | - | TA 0000 180 | TA 0000 | TA 0000 |
| | 10.0 mm ² | - | | | |
| Cable lugs for PE connection | | | | Pieces | Part Number |
| Cable lug | 6.0 mm ² | - | 20 | N15 006 000 9Z | N15 010 000 7Z |
| | 10.0 mm ² | - | 20 | | |
| Further tools see catalogue "Tools" | | | | | |

heavy|mate[®] M Characteristics 4 contacts, 4 + ⊕ , 5 contacts module for stamped contacts

| General Characteristics | Standard | Value |
|-------------------------------------|-----------------|---|
| Number of contacts | | 4 + ⊕ / 5 |
| Termination technique | | crimp |
| Wire gauge | | 0.5 - 4.0 mm ² (AWG 20 - 12) |
| Flammability | UL 94 | V-0 |
| Electrical Characteristics | | |
| Rated voltage | IEC 60664-1 | 1000 V ¹⁾ |
| Pollution degree | IEC 60664-1 | 3 |
| Installation (overvoltage) category | IEC 60664-1 | III |
| Material group | IEC 60664-1 | II |
| Rated impulse withstand voltage | IEC 60664-1 | 8.0 kV |
| Current carrying capacity | IEC 60512-5-2 | see derating curves |
| Contact resistance | IEC 60512-2-1 | ≤ 5 mΩ |
| Insulation resistance | IEC 60512-3-1 | ≥ 10 ¹⁰ Ω |
| Climatical Characteristics | | |
| Climatic category | IEC 60068-1 | 40 / 125 / 21 |
| Upper temperature | IEC 60512-11-9 | + 125 °C |
| Lower temperature | IEC 60512-11-10 | - 40 °C |
| Mechanical Characteristics | | |
| IP-degree of protection | IEC 60529 | 20 |
| Mechanical operation | IEC 60512-9-1 | ≥ 500 mating cycles |
| Materials | | |
| Module | | PA 6.6 GF |
| Colour module | | black |
| Male contacts | | CuZn (brass) |
| Female contacts | | CuSn (bronze) |
| Contact plating | | Ag (silver) |

Derating Curves

1.5 mm²

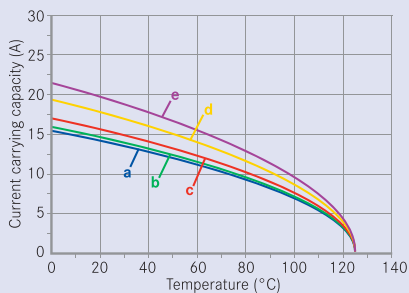

| Curve | Frame |
|-------|-----------|
| a | 7 Modules |
| b | 5 Modules |
| c | 3 Modules |
| d | 2 Modules |
| | 1 Modules |

2.5 mm²

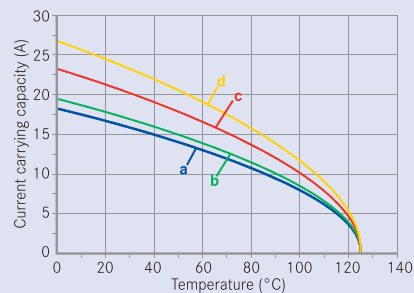

| Curve | Frame |
|-------|-------------|
| a | 7 Modules |
| b | 3-5 Modules |
| c | 2 Modules |
| d | 1 Modules |

4 mm²

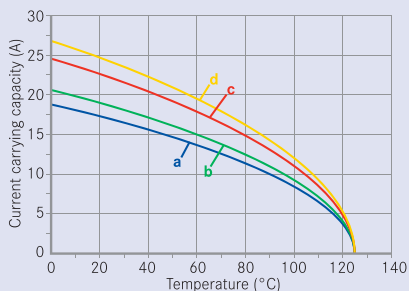

| Curve | Frame |
|-------|-------------|
| a | 7 Modules |
| b | 5 Modules |
| c | 3 Modules |
| d | 1+2 Modules |

heavy|mate® M 4 contacts, 4 + PE, 5 contacts module + crimp contacts

| Description | Part Number | Drawing | Figure |
|--|--|---------|--------|
| 4 contacts, 4 + PE, 5 contacts module, PE contact 2 mm first-to-mate (Please order contacts separately) | | | |
| Pin module | C146 D04 001 E8 (4 pol) C146 D05 001 E8 (4 +PE) C146 D05 801 E8 (5 pol) | | |
| Socket module | C146 C04 001 E8 (4 pol) C146 C05 001 E8 (4 + PE) C146 C05 801 E8 (5 pol) | | |

| Supplied as | for wire gauge | AWG | Pieces | Part Number | | Figure |
|-------------|----------------|-----|--------|--------------|----------------|--------|
| | | | | Male contact | Female contact | |

Stamped single contacts

| | | | | | | |
|----------------|---------------------------|---------|-----|---------------------|---------------------|--|
| silver plating | 0.5 - 1.5 mm ² | 20 - 16 | 100 | VN01 025 0001 (101) | VN02 025 0001 (101) | |
| | 1.5 - 2.5 mm ² | 16 - 14 | 100 | VN01 025 0010 (101) | VN02 025 0010 (101) | |
| | 2.5 - 4.0 mm ² | 12 | 100 | VN01 025 0043 (1) | VN02 025 0043 (1) | |
| gold plating | 0.5 - 1.5 mm ² | 20 - 16 | 100 | VN01 025 0001 (102) | VN02 025 0001 (102) | |
| | 1.5 - 2.5 mm ² | 16 - 14 | 100 | VN01 025 0010 (102) | VN02 025 0010 (102) | |

Stamped Contacts on reel for hand crimp tools

| | | | | | | |
|----------------|---------------------------|---------|------|-------------------|-------------------|--|
| silver plating | 0.5 - 1.5 mm ² | 20 - 16 | 2000 | TN01 025 0001 (1) | TN02 025 0001 (1) | |
| | 1.5 - 2.5 mm ² | 16 - 14 | 2000 | TN01 025 0010 (1) | TN02 025 0010 (1) | |
| gold plating | 0.5 - 1.5 mm ² | 20 - 16 | 2000 | TN01 025 0001 (2) | TN02 025 0001 (2) | |
| | 1.5 - 2.5 mm ² | 16 - 14 | 2000 | TN01 025 0010 (2) | TN02 025 0010 (2) | |

Contacts on reel for crimp machines contact feeding left hand side

| | | | | | | |
|----------------|---------------------------|---------|------|-------------------|-------------------|--|
| silver plating | 0.5 - 1.5 mm ² | 20 - 16 | 2000 | TN01 025 0001 (1) | TN02 025 0001 (1) | |
| | 1.5 - 2.5 mm ² | 16 - 14 | 2000 | TN01 025 0010 (1) | TN02 025 0010 (1) | |
| | 2.5 - 4 mm ² | 12 | 2000 | TN01 025 0043 (1) | TN02 025 0043 (1) | |

Tools

| Description | for wire gauge | Part Number | | |
|-----------------------------------|---------------------------|-------------------|---------------|---------------|
| | | Contact locator | Crimping dies | Tool |
| Removal tool for contacts | - | - | - | FG 0200 146 1 |
| Removal tool for modules | - | - | - | FG 1000 146 |
| Crimping tool for single contacts | 0.5 - 1.5 mm ² | TA 0004 146 000 1 | TA 0000 163 | TA 0000 |
| | 1.5 - 2.5 mm ² | TA 0005 146 000 3 | TA 0000 141 | |
| | 2.5 - 4.0 mm ² | TA 0003 146 000 1 | TA 0000 121 | |

Further tools see catalogue "Tools"

heavy|mate[®] M Characteristics 5 contacts module for turned contacts

| General Characteristics | Standard | Value |
|-------------------------------------|-----------------|---|
| Number of contacts | | 5 |
| Termination technique | | crimp |
| Wire gauge | | 0.5 - 4.0 mm ² (AWG 20 - 12) |
| Flammability | UL 94 | V-0 |
| Electrical Characteristics | | |
| Rated voltage | IEC 60664-1 | 400 V |
| Pollution degree | IEC 60664-1 | 3 |
| Installation (overvoltage) category | IEC 60664-1 | III |
| Material group | IEC 60664-1 | II |
| Rated impulse withstand voltage | IEC 60664-1 | 6.0 kV |
| Current carrying capacity | IEC 60512-5-2 | see derating curves |
| Contact resistance | IEC 60512-2-1 | ≤ 2 mΩ |
| Insulation resistance | IEC 60512-3-1 | ≥ 10 ¹⁰ Ω |
| Climatical Characteristics | | |
| Climatic category | IEC 60068-1 | 40 / 125 / 21 |
| Upper temperature | IEC 60512-11-9 | + 125 °C |
| Lower temperature | IEC 60512-11-10 | - 40 °C |
| Mechanical Characteristics | | |
| Mechanical operation | IEC 60512-9-1 | ≥ 500 mating cycles |
| Materials | | |
| Module | | PA 6.6 GF |
| Colour module | | black |
| Contacts | | Cu-alloy |
| Contact plating | | Ag (silver) |

Derating Curves

2.5 mm²

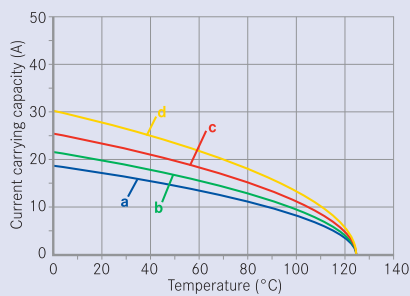



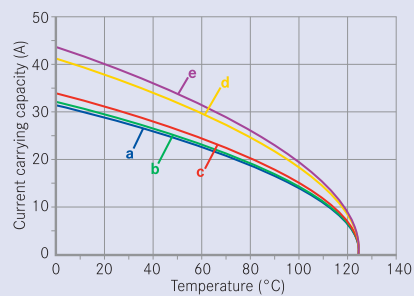

| Curve | Frame |
|-------|-------------|
| a | 7 Modules |
| b | 5 Modules |
| c | 3 Modules |
| d | 1+2 Modules |

4 mm²

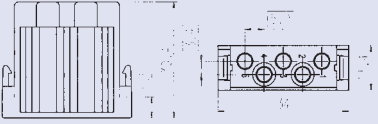

| Curve | Frame |
|-------|-----------|
| a | 7 Modules |
| b | 5 Modules |
| c | 3 Modules |
| d | 2 Modules |
| e | 1 Modules |

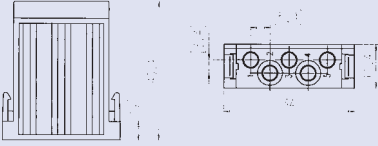
heavy|mate® M 5 contacts module + crimp contacts

| Description | Part Number | Drawing | Figure |
|---|-----------------|--|---|
| 5 contacts module (Please order contacts separately) | | | |
| Pin module | C146 A05 001 E8 |  |  |
| Socket module | C146 B05 001 E8 |  |  |

| Supplied as | for wire gauge | AWG | Pieces | Part Number | | Figure |
|--|----------------------------|-----|--------|--------------------|--------------------|--|
| | | | | Male contact | Female contact | |
| Turned 2.5 mm crimp contacts single contact | | | | | | |
| silver plating | 0.5 mm ² | 20 | 100 | VN01 025 0029 (1)C | VN02 025 0029 (1)C |  |
| | 0.75 - 1.0 mm ² | 18 | 100 | VN01 025 0030 (1)C | VN02 025 0030 (1)C | |
| | 1.5 mm ² | 16 | 100 | VN01 025 0031 (1)C | VN02 025 0031 (1)C | |
| | 2.5 mm ² | 14 | 100 | VN01 025 0032 (1)C | VN02 025 0032 (1)C | |
| | 4.0 mm ² | 12 | 100 | VN01 025 0033 (1)C | VN02 025 0033 (1)C | |

Tools



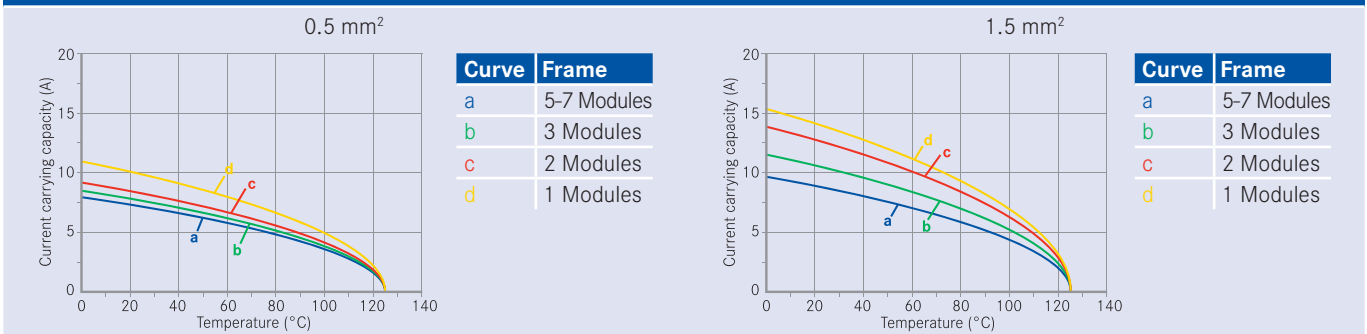

| Description | for wire gauge | Part Number | | |
|-------------------------------------|---------------------------|-------------------|---------------|---------------|
| | | Contact locator | Crimping dies | Tool |
| Removal tool for contacts | - | - | - | FG 0300 146 4 |
| Removal tool for modules | - | - | - | FG 1000 146 |
| Crimping tool for single contacts | 0.5 - 2.5 mm ² | TA 0010 146 000 2 | TA 0000 144 | TA 0000 |
| | 4.0 mm ² | TA 0010 146 000 3 | TA 0000 124 | |
| Further tools see catalogue "Tools" | | | | |

| General Characteristics | Standard | Value |
|-------------------------------------|-----------------|--|
| Number of contacts | | 10 |
| Termination technique | | crimp |
| Wire gauge | | 0.14 - 2.5 mm ² (AWG 26 - 14) |
| Flammability | UL 94 | V-0 |
| Electrical Characteristics | | |
| Rated voltage | IEC 60664-1 | 400 V |
| Pollution degree | IEC 60664-1 | 3 |
| Installation (overvoltage) category | IEC 60664-1 | III |
| Material group | IEC 60664-1 | II |
| Rated impulse withstand voltage | IEC 60664-1 | 6.0 KV |
| Current carrying capacity | IEC 60512-5-2 | see derating curves |
| Contact resistance | IEC 60512-2-1 | ≤ 5 mΩ |
| Insulation resistance | IEC 60512-3-1 | ≥ 10 ¹⁰ Ω |
| Climatical Characteristics | | |
| Climatic category | IEC 60068-1 | 40 / 125 / 21 |
| Upper temperature | IEC 60512-11-9 | + 125 °C |
| Lower temperature | IEC 60512-11-10 | - 40 °C |
| Mechanical Characteristics | | |
| Mechanical operation | IEC 60512-9-1 | ≥ 500 mating cycles |
| Materials | | |
| Module | | PA 6.6 GF |
| Colour module | | black |
| Male contacts | | CuZn (brass) |
| Female contacts | | CuSn (bronze) |
| Contact plating | | Ag (silver) |

Derating Curves



heavy|mate® M 10 contacts module + crimp contacts

| Description | Part Number | Drawing | Figure |
|--|-----------------|--|---|
| 10 contacts module (Please order contacts separately) | | | |
| Pin module | C146 D10 001 E8 |  |  |
| Socket module | C146 C10 001 G8 |  |  |

| Supplied as | for wire gauge | AWG | Pieces | Part Number | | Figure |
|-------------|----------------|-----|--------|--------------|----------------|--------|
| | | | | Male contact | Female contact | |

Stamped 1.6 mm single contact

| | | | | | | |
|----------------|----------------------------|---------|-----|-------------------|-------------------|--|
| silver plating | 0.14 - 0.5 mm ² | 26 - 20 | 100 | VN01 016 0003 (1) | VN02 016 0003 (1) |  |
| | 0.5 - 1.5 mm ² | 20 - 16 | 100 | VN01 016 0002 (1) | VN02 016 0002 (1) | |
| | 1.5 - 2.5 mm ² | 16 - 14 | 100 | VN01 016 0005 (1) | VN02 016 0005 (1) | |
| gold plating | 0.14 - 0.5 mm ² | 26 - 20 | 100 | VN01 016 0003 (2) | VN02 016 0003 (2) | |
| | 0.5 - 1.5 mm ² | 20 - 16 | 100 | VN01 016 0002 (2) | VN02 016 0002 (2) | |
| | 1.5 - 2.5 mm ² | 16 - 14 | 100 | VN01 016 0005 (2) | VN02 016 0005 (2) | |

Stamped Contacts on reel for hand crimp tools

| | | | | | | |
|--------------------------------|----------------------------|---------|-----|-------------------|-------------------|---|
| silver plating Standard | 0.14 - 0.5 mm ² | 26 - 20 | 200 | ZN01 016 0003 (1) | ZN02 016 0003 (1) |  |
| | 0.5 - 1.5 mm ² | 20 - 16 | 200 | ZN01 016 0002 (1) | ZN02 016 0002 (1) | |
| | 1.5 - 2.5 mm ² | 16 - 14 | 200 | ZN01 016 0005 (1) | ZN02 016 0005 (1) | |
| silver plating High current | 0.5 - 1.5 mm ² | 20 - 16 | 200 | ZN01 016 0015 (1) | ZN02 016 0015 (1) | |
| | 1.5 - 2.5 mm ² | 16 - 14 | 200 | ZN01 016 0016 (1) | ZN02 016 0016 (1) | |
| gold plating Standard | 0.14 - 0.5 mm ² | 26 - 20 | 200 | ZN01 016 0003 (2) | ZN02 016 0003 (2) | |
| | 0.5 - 1.5 mm ² | 20 - 16 | 200 | ZN01 016 0002 (2) | ZN02 016 0002 (2) | |
| | 1.5 - 2.5 mm ² | 16 - 14 | 200 | ZN01 016 0005 (2) | ZN02 016 0005 (2) | |

Stamped Contacts on reel for crimp machines contact feeding left hand side

| | | | | | | |
|--------------------------------|----------------------------|---------|------|-------------------|-------------------|---|
| silver plating Standard | 0.14 - 0.5 mm ² | 26 - 20 | 2000 | TN01 016 0003 (1) | TN02 016 0003 (1) |  |
| | 0.5 - 1.5 mm ² | 20 - 16 | 2000 | TN01 016 0002 (1) | TN02 016 0002 (1) | |
| | 1.5 - 2.5 mm ² | 16 - 14 | 2000 | TN01 016 0005 (1) | TN02 016 0005 (1) | |
| silver plating High current | 0.5 - 1.5 mm ² | 20 - 16 | 2000 | TN01 016 0015 (1) | TN02 016 0015 (1) | |
| | 1.5 - 2.5 mm ² | 18 - 14 | 2000 | TN01 016 0016 (1) | TN02 016 0016 (1) | |
| gold plating Standard | 0.14 - 0.5 mm ² | 26 - 20 | 2000 | TN01 016 0003 (2) | TN02 016 0003 (2) | |
| | 0.5 - 1.5 mm ² | 20 - 16 | 2000 | TN01 016 0002 (2) | TN02 016 0002 (2) | |
| | 1.5 - 2.5 mm ² | 16 - 14 | 2000 | TN01 016 0005 (2) | TN02 016 0005 (2) | |

Tools

| Description | for wire gauge | Part Number | | |
|------------------------------------|---|-------------------|---------------|--------------------------------|
| | | Contact locator | Crimping dies | Tool |
| Removal tool for contacts/ modules | - | - | - | FG 0300 146 1 / FG 1000 146 |
| Service crimping tool | 0.14 - 0.5 mm ² 0.5 - 1.5 mm ² | - | - | TA 0100 146 |
| Crimping tool for single contacts | 0.14 - 0.5 mm ² | TA 0001 146 000 1 | TA 0000 202 | TA 0000 |
| | 0.5 - 1.5 mm ² | TA 0002 146 000 1 | TA 0000 163 | |
| | 1.5 - 2.5 mm ² | TA 0007 146 000 3 | TA 0000 141 | |

Further tools see catalogue "Tools"





heavy|mate[®] M Characteristics 10 contacts module for turned contacts

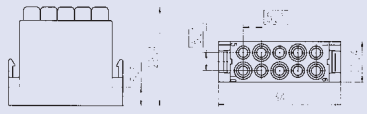

| General Characteristics | Standard | Value |
|-------------------------------------|-----------------|--|
| Number of contacts | | 10 |
| Termination technique | | crimp |
| Wire gauge | | 0.14 - 2.5 mm ² (AWG 26 - 14) |
| Flammability | UL 94 | V-0 |
| Electrical Characteristics | | |
| Rated voltage | IEC 60664-1 | 400 V |
| Pollution degree | IEC 60664-1 | 3 |
| Installation (overvoltage) category | IEC 60664-1 | III |
| Material group | IEC 60664-1 | II (PA) |
| Rated impulse withstand voltage | IEC 60664-1 | 6.0 kV |
| Current carrying capacity | IEC 60512-5-2 | siehe Derating Kurven |
| Contact resistance | IEC 60512-2-1 | ≤ 5 mΩ |
| Insulation resistance | IEC 60512-3-1 | ≥ 10 ¹⁰ Ω |
| Climatical Characteristics | | |
| Climatic category | IEC 60068-1 | 40 / 100 / 21 |
| Upper temperature | IEC 60512-11-9 | + 100 °C |
| Lower temperature | IEC 60512-11-10 | - 40 °C |
| Mechanical Characteristics | | |
| Mechanical operation | IEC 60512-9-1 | ≥ 500 Steckzyklen |
| Materials | | |
| Module | | PA 6.6 GF |
| Colour module | | black |
| Contacts | | CuZn (brass) |
| Contact plating | | Ag (silver) |

Derating Curves

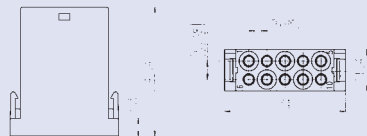

heavy|mate® M 10 contacts module + crimp contacts

| Description | Part Number | Drawing | Figure |
|--|-----------------|--|---|
| 10 contacts module (Please order contacts separately) | | | |
| Pin module | C146 A10 001 E8 |  |  |
| Socket module | C146 B10 001 E8 |  |  |

| Supplied as | for wire gauge | AWG | Pieces | Part Number | | Figure |
|--|----------------------------|---------|--------|---------------------|---------------------|---|
| | | | | Male contact | Female contact | |
| Turned 1.6 mm crimp contacts single contact | | | | | | |
| silver plating | 0.14 - 0.37mm ² | 26 - 22 | 100 | VN01 016 0024 (1)C | VN02 016 0024 (1)C |  |
| | 0.5 mm ² | 20 | 100 | VN01 016 0025 (1)C | VN02 016 0025 (1)C | |
| | 0.75 - 1.0 mm ² | 20 - 16 | 100 | VN01 016 0026 (1)C | VN02 016 0026 (1)C | |
| | 1.5 mm ² | 16 - 15 | 100 | VN01 016 0027 (1)C | VN02 016 0027 (1)C | |
| | 2.5 mm ² | 14 | 100 | VN01 016 0028 (1)C | VN02 016 0028 (1)C | |
| gold plating | 0.14 - 0.37mm ² | 26 - 22 | 100 | VN01 016 0024 (2)C | VN02 016 0024 (2)C | |
| | 0.5 mm ² | 20 | 100 | VN01 016 0025 (2)C | VN02 016 0025 (2)C | |
| | 0.75 - 1.0 mm ² | 20 - 16 | 100 | VN01 016 0026 (2)C | VN02 016 0026 (2)C | |
| | 1.5 mm ² | 16 - 15 | 100 | VN01 016 0027 (2)C | VN02 016 0027 (2)C | |
| | 2.5 mm ² | 14 | 100 | VN01 016 0028 (2)C | VN02 016 0028 (2)C | |
| FO contacts | | | | | | |
| single contact | 1.0 mm POF | - | 10 | VN01 016 0040 (8) X | VN02 016 0040 (8) X |  |

| Tools | | | | | |
|---|--|-------------------|---------------|---|---------------|
| Description | for wire gauge | Part Number | | | Tool |
| | | Contact locator | Crimping dies | | |
| Removal tool for contacts | - | - | - | - | FG 0300 146 1 |
| Removal tool for modules | - | - | - | - | FG 1000 146 |
| Crimping tool for single contacts | 0.14 - 1.0 mm ² 1.5 mm ² 2.5 mm ² | TA 0010 146 000 1 | TA 0000 184 | | TA 0000 |
| Crimpzange für LWL Kontakte ¹⁾ | 1.0 mm POF/FO | - | - | - | TB 0500 146 |

Further tools see catalogue "Tools"

| General Characteristics | Standard | Value |
|-------------------------------------|-----------------|--|
| Number of contacts | | 20 |
| Termination technique | | crimp |
| Wire gauge | | 0.09 - 0.5 mm ² (AWG 28 - 20) |
| Flammability | UL 94 | V-0 |
| Electrical Characteristics | | |
| Rated voltage | IEC 60664-1 | 63 V |
| Pollution degree | IEC 60664-1 | 3 |
| Installation (overvoltage) category | IEC 60664-1 | III |
| Material group | IEC 60664-1 | II (PA) |
| Rated impulse withstand voltage | IEC 60664-1 | 4.0 KV |
| Current carrying capacity | IEC 60512-5-2 | see derating curves |
| Contact resistance | IEC 60512-2-1 | ≤ 5 mΩ |
| Insulation resistance | IEC 60512-3-1 | ≥ 10 ¹⁰ Ω |
| Climatical Characteristics | | |
| Climatic category | IEC 60068-1 | 40 / 125 / 21 |
| Upper temperature | IEC 60512-11-9 | + 125 °C |
| Lower temperature | IEC 60512-11-10 | - 40 °C |
| Mechanical Characteristics | | |
| Mechanical operation | IEC 60512-9-1 | ≥ 500 mating cycles |
| Materials | | |
| Module | | PA 6.6 GF |
| Colour module | | black |
| Male contacts | | CuZn (brass) |
| Female contacts | | CuSn (bronze) |
| Contact plating | | Au (gold) |

Derating-Kurven

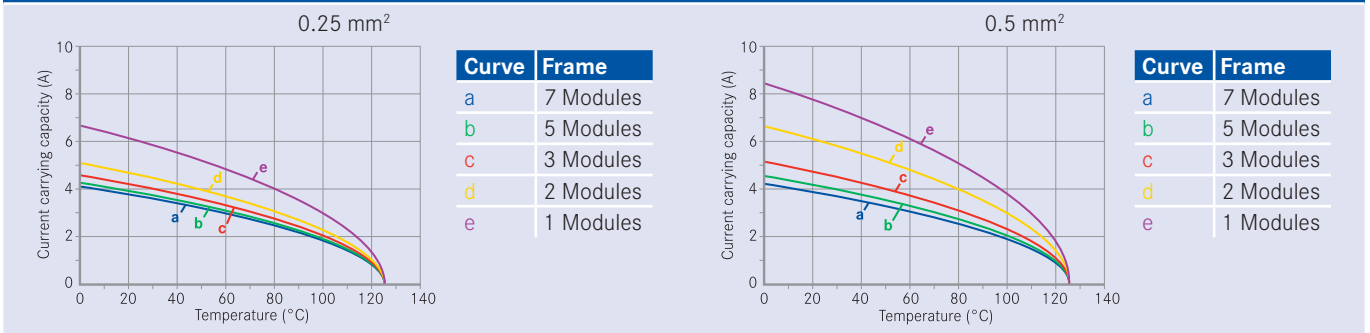



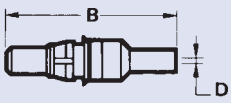
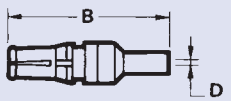
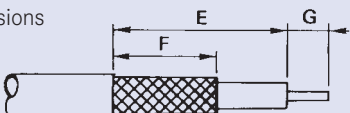

heavy|mate[®] M Characteristics 3 contacts module for coax contacts

| General Characteristics | Standard | Value |
|-------------------------------------|-----------------|---------------------|
| Number of contacts | | 3 |
| Termination technique | | crimp, solder |
| Flammability | UL 94 | V-0 |
| Electrical Characteristics | | |
| Rated voltage | IEC 60664-1 | 250 V |
| Pollution degree | IEC 60664-1 | 3 |
| Installation (overvoltage) category | IEC 60664-1 | III |
| Material group | IEC 60664-1 | II |
| Impedance | | 50 Ω |
| Working frequency | | 2 GHz |
| Climatical Characteristics | | |
| Climatic category | IEC 60068-1 | 40 / 125 / 21 |
| Upper temperature | IEC 60512-11-9 | + 125 °C |
| Lower temperature | IEC 60512-11-10 | - 40 °C |
| Mechanical Characteristics | | |
| Mechanical operation | IEC 60512-9-1 | ≥ 500 mating cycles |
| Materials | | |
| Module | | PA 6.6 GF |
| Colour module | | redbrown |
| Contact plating | | Au (gold) |

Contact dimensions

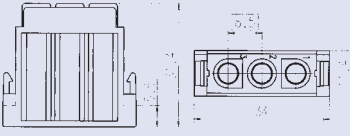
| | Part Number | B | D | E | F | G |
|---|---------------|------|-----|-----|-----|---|
| Male contact  | 17 DM 537 401 | 23.6 | 1.7 | 7.9 | 6.3 | 2 |
| Female contact  | 17 DM 537 421 | 23.6 | 1.7 | 7.9 | 6.3 | 2 |
| | 17 DM 537 405 | 26.3 | 3.2 | 9.5 | 7.9 | 2 |
| Stripping dimensions  | 17 DM 537 425 | 26.3 | 3.2 | 9.5 | 7.9 | 2 |

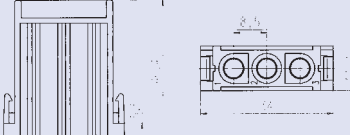
heavy|mate® M 3 contacts module for coax contacts + crimp contacts

| Description | Part Number | Drawing | Figure |
|---|-----------------|--|---|
| 3 contacts module for coax contacts (Please order contacts separately) | | | |
| Pin module | C146 A03 501 E8 |  |  |
| Socket module | C146 B03 501 E8 |  |  |

| Supplied as | for wire gauge | AWG | Pieces | Part Number | | Figure |
|--------------------------------------|------------------|-----|--------|---------------|----------------|--|
| | | | | Male contact | Female contact | |
| Single contacts ¹⁾ | | | | | | |
| | RG 174, 179, 316 | | 1 | 17 DM 537 401 | 17 DM 537 421 |  |
| | RG 58 | | 1 | 17 DM 537 405 | 17 DM 537 425 | |

| Tools | | | | | | |
|-------------------------------------|------------------|------------------|-------|-------|---------------|---------------|
| Description | for cable size | 6-hex-size in mm | | | Part Number | |
| | | | | | Crimping dies | Tool |
| Removal tool for contacts | - | - | - | - | - | FG 0300 146 3 |
| Removal tool for modules | - | - | - | - | - | FG 1000 146 |
| Crimping tool for single contacts | RG 58 | 5.4 | (6.5) | (1.7) | TA 0000 401 | TA 0000 |
| | RG 174, 179, 316 | 3.25 | (4.5) | (1.7) | TA 0000 402 | TA 0000 |
| Further tools see catalogue "Tools" | | | | | | |

Brief information

- For integration of standard RJ45 components
- Worldwide real-time access on machines and facilities
- Easy assembly through the use of standard RJ45 components
- One connector for power, signal and data transmission
- 4 additional power crimp contacts
- Time- and money saving through the use of similar active- and passive components
- Unitary transmission protocol in the office- and production environment.
- Meets CAT 5 for Ethernet acc. ISO/IEC 11801

| General Characteristics | Standard | Value module | Value RJ45 |
|---------------------------------|-----------------|---------------------------|---------------------|
| Number of contacts | | 4 | 8 |
| Termination technique | | crimp | mate |
| Wire gauge | | 0.14 - 2.5mm ² | |
| Flammability | UL 94 | V-0 | V - 0 |
| Electrical Characteristics | | | |
| Rated voltage | IEC 60664-1 | 400 V AC | 125 V AC |
| Rated impulse withstand voltage | IEC 60664-1 | 6 kV | 1.8 kV |
| Current carrying capacity | IEC 60512-5-2 | 13 A ¹⁾ | 1.5 A |
| Contact resistance | IEC 60512-2-1 | ≤ 5 mΩ | ≤ 20 mΩ |
| Insulation resistance | IEC 60512-3-1 | 10 ¹⁰ Ω | 5 ⁹ Ω |
| Climatical Characteristics | | | |
| Upper temperature | IEC 60512-11-9 | + 100 °C | + 80 °C |
| Lower temperature | IEC 60512-11-10 | | - 20 °C |
| Mechanical Characteristics | | | |
| Mechanical operation | IEC 60512-9-1 | ≥ 500 mating cycles | ≥ 500 mating cycles |
| Materials | | | |
| Module | | PA 6.6 GF | |
| Colour module | | black | black |
| Male contacts | | CuZn (brass) | CuSn (bronze) |
| Female contacts | | CuZn (brass) | CuSn (bronze) |
| Contact plating | | Ag (silver) | Au (gold) |

heavy|mate® M RJ module + crimp contacts

| Description | Part Number | Drawing | Figure |
|------------------|-----------------|---------|--------|
| RJ module | | | |
| Pin module | C146 E12 001 E8 | | |
| Socket module | C146 F12 001 G8 | | |

| Supplied as | for wire gauge | AWG | Pieces | Part Number | | Figure |
|--------------------------------------|-----------------------------|---------|--------|--------------------|--------------------|--------|
| | | | | Male contact | Female contact | |
| Turned 1.6 mm single contacts | | | | | | |
| silver plating | 0.14 - 0.37 mm ² | 26 - 22 | 100 | VN01 016 0024 (1)C | VN02 016 0024 (1)C | |
| | 0.5 mm ² | 20 | 100 | VN01 016 0025 (1)C | VN02 016 0025 (1)C | |
| | 0.75 - 1.0 mm ² | 20 - 16 | 100 | VN01 016 0026 (1)C | VN02 016 0026 (1)C | |
| | 1.5 mm ² | 16 - 15 | 100 | VN01 016 0027 (1)C | VN02 016 0027 (1)C | |
| | 2.5 mm ² | 14 | 100 | VN01 016 0028 (1)C | VN02 016 0028 (1)C | |
| gold plating | 0.14 - 0.37 mm ² | 26 - 22 | 100 | VN01 016 0024 (2)C | VN02 016 0024 (2)C | |
| | 0.5 mm ² | 20 | 100 | VN01 016 0025 (2)C | VN02 016 0025 (2)C | |
| | 0.75 - 1.0 mm ² | 20 - 16 | 100 | VN01 016 0026 (2)C | VN02 016 0026 (2)C | |
| | 1.5 mm ² | 16 - 15 | 100 | VN01 016 0027 (2)C | VN02 016 0027 (2)C | |
| | 2.5 mm ² | 14 | 100 | VN01 016 0028 (2)C | VN02 016 0028 (2)C | |

Brief information

- Power, signal and pneumatic within a single connector
- Very stable brass contacts
- Pneumatic socket contacts with barrier, closes when the connector is open
- Available with single or double connections
- Connection for 2.5 mm or 4 mm PTFE (Teflon)-tubes
- Tubes can be disassembled from the terminations

| General Characteristics | Standard | Value |
|----------------------------|----------|-----------------------------------|
| Number of contacts | | 1 / 2 |
| Termination technique | | tube termination |
| Wire gauge | | 2.5 mm / 4.0 mm |
| Flammability | UL 94 | V-0 |
| Technical Characteristics | | |
| Operating pressure | | 8 bar with PTFE tube |
| Operating path | | 4.0 mm |
| Locking | | locking on one side |
| Pneumatic tube | | only use PTFE tubes ¹⁾ |
| Climatical Characteristics | | |
| Upper temperature | | +100 °C |
| Lower temperature | | - 20 °C |
| Mechanical Characteristics | | |
| Mechanical operation | | 5000 mating cycles |
| Materials | | |
| Module | | PA 6.6 GF |
| Colour module | | black |
| Contacts | | Brass MS 58 |

| Description | Part Number | Drawing | Figure |
|-------------------------|--|--|---|
| Pneumatic module | | | |
| Pin module | C146 G01 014 G8 (2.5 mm) C146 G01 024 G8 (4.0 mm) |  |  |
| Socket module | C146 H01 034 G8 (2.5 mm) C146 H01 044 G8 (4.0 mm) |  |  |
| Pin module | C146 G02 014 G8 (2.5 mm) C146 G02 024 G8 (4.0 mm) |  |  |
| Socket module | C146 H02 034 G8 (2.5 mm) C146 H02 044 G8 (4.0 mm) |  |  |

heavy|mate[®] M Characteristics Shielded module

| General Characteristics | Standard | Value |
|-------------------------------------|-----------------|--|
| Number of contacts | | 2X4 |
| Termination technique | | crimp |
| Wire gauge | | 0.14 – 2.5 mm ² (AWG 26-14) |
| Flammability | UL94 | V-0 |
| Electrical Characteristics | | |
| Rated voltage | IEC 60664-1 | 50V |
| Pollution degree | IEC 60664-1 | 3 |
| Installation (overvoltage) category | IEC 60664-1 | 3 |
| Material group | IEC 60664-1 | 3b |
| Rated impulse withstand voltage | IEC 60664-1 | 0.8 kV |
| Current carrying capacity | IEC 60512-5-2 | 10A |
| Contact resistance | IEC 60512-2-1 | ≤ 5mΩ |
| Climatical Characteristics | | |
| Climatic category | IEC 60068-1 | 40 / 125 / 21 |
| Upper temperature | IEC 60512-11-9 | 125°C |
| Lower temperature | IEC 60512-11-10 | -40°C |
| Mechanical Characteristics | | |
| Mechanical operation | IEC 60512-9-1 | ≥ 500 mating cycles |
| Materials | | |
| Module | | PC |
| Colour module | | grey |
| Contacts | | Cu-alloy |
| Contact plating | | Au (gold) |

heavy|mate® M Shielded module + crimp contacts

| Description | Part Number | Drawing | Figure |
|---|-----------------|--|---|
| Contact insert 2x4 contacts (Please order contacts separately) | | | |
| Pin module | C146 A08 102 E8 |  |  |
| Male contact carriers 4 contacts | C146 A05 100 G8 |  |  |
| Socket module | C146 B08 102 E8 |  |  |
| Female contact carriers 4 contacts | C146 B05 100 G8 |  |  |

| Supplied as | for wire gauge | AWG | Pieces | Part Number | | Figure |
|------------------------------------|-----------------------------|-------|--------|------------------|------------------|---|
| | | | | Male contact | Female contact | |
| Turned 1.6mm crimp contacts | | | | | | |
| Single contacts | 0.14 – 0.37 mm ² | 26-22 | 100 | VN01 016 0024 2C | VN02 016 0024 2C |  |
| | 0.5 mm ² | 20 | 100 | VN01 016 0025 2C | VN02 016 0025 2C | |
| | 0.75 – 1.0 mm ² | 20-16 | 100 | VN01 016 0026 2C | VN02 016 0026 2C | |
| | 1.5 mm ² | 16-15 | 100 | VN01 016 0027 2C | VN02 016 0027 2C | |
| | 2.5 mm ² | 14 | 100 | VN01 016 0028 2C | VN02 016 0028 2C | |

| Tools | | | | |
|---------------------------|----------------|-----------------|---------------|----------------------|
| Description | for wire gauge | Part Number | | |
| | | Contact locator | Crimping dies | Tool |
| Crimping tool | - | - | - | TA 0000 oder TA 0500 |
| Crimping dies | - | - | - | TA 00000 184 |
| Contact locator | - | - | - | TA 0010 146 000 1 |
| Removal tool for contacts | - | - | - | FG 0300 146 1 |

Further tools see catalogue "Tools"

| Contact size | Part Number | Figure |
|----------------|---------------|--|
| 1.0 mm | 17D 438 SP |  |
| 1.6 mm | FG 0300 146 1 |  |
| 2.5 mm turned | FG 0300 146 4 |  |
| 2.5 mm stamped | FG 0200 146 1 |  |
| 3.6 mm | FG 0300 146 3 |  |

| Contact size | Part Number | Figure |
|--------------------------|---|--|
| Removal tool for modules | FG 1000 146 |  |
| Blank modules | C146 A00 001 E8 (pin) C146 B00 001 E8 (socket) |  |
| Module coupler | C146 10Z000 002 8 |  |
| Assembly angle | C146 10Z001 001 8 |  |
| Strain relief | C146 10Z002 001 8 |  |

The image shows a close-up of industrial machinery, likely a pump or valve assembly. The main components are painted a vibrant blue. In the upper center, there is a large, cylindrical stainless steel component. To its left, a circular pressure gauge with a white face and black markings is mounted. Several large, black handwheels for manual operation are visible. The machinery is connected to various pipes and fittings, some of which are also blue, while others are silver metal. The background is a plain, light-colored wall.

heavy | mate[®] Q

- Compact design
- Even in a metal housing
- Rated voltage up to 500 V
- Numbers of contacts: 5 + PE, 7 + PE



| Approvals, Testhouse | Characteristics | Approval-Number |
|--|-----------------|-----------------|
| UL  | In preparation | In preparation |
| CSA  | In preparation | In preparation |

heavy|mate® Q Characteristics contact inserts 5 + PE

| General Characteristics | Standard | Value |
|-------------------------------------|-----------------|--|
| Number of contacts | | 5 + PE |
| Termination technique | | crimp |
| Wire gauge | | 0.5 – 4.0 mm ² (AWG 20-12) |
| Flammability | UL94 | V-0 |
| Electrical Characteristics | | |
| Rated voltage | IEC 60664-1 | 400 V (conductor – conductor) 230 V (conductor – earth) |
| Pollution degree | IEC 60664-1 | 3 |
| Installation (overvoltage) category | IEC 60664-1 | 3 |
| Material group | IEC 60664-1 | 3b |
| Rated impulse withstand voltage | IEC 60664-1 | 6 kV |
| Current carrying capacity | IEC 60512-5-2 | see derating curves |
| Contact resistance | IEC 60512-2-1 | ≤ 5 mΩ |
| Insulation resistance | IEC 60512-3-1 | ≥ 10 ¹⁰ Ω |
| Climatical Characteristics | | |
| Climatic category | IEC 60068-1 | 40/125/21 |
| Upper temperature | IEC 60512-11-9 | +125°C |
| Lower temperature | IEC 60512-11-10 | -40°C |
| Mechanical Characteristics | | |
| Mechanical operation | IEC 60512-9-1 | ≥500 mating cycles |
| Materials | | |
| Insert | | PC |
| Colour insert | | grey |
| Contacts | | Cu-alloy |
| Contact plating | | Ag (silver) /Au (gold) |

Derating Curves

In preparation

| Description | Part Number | Drawing | Figure |
|-------------|-------------|---------|--------|
|-------------|-------------|---------|--------|

Contact insert 5 +PE (Please order contacts separately)

| | | | |
|---------------|--------------------|--|--|
| Male insert | C146 10A005 500 12 | | |
| Female insert | C146 10B005 500 12 | | |

Coding element

| | | | |
|----------------|---------------|--|--|
| Coding element | N17 045 000 1 | | |
|----------------|---------------|--|--|

Contact arrangement

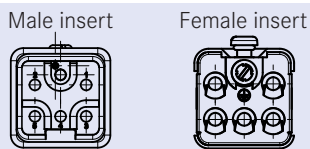

| Supplied as | for wire gauge | AWG | Pieces | Part Number | | Figure |
|-------------|----------------|-----|--------|--------------|----------------|--------|
| | | | | Male contact | Female contact | |

Turned 2.5 mm crimp contacts single contact

| | | | | | | |
|----------------|----------------------------|----|-----|------------------|------------------|--|
| silver plating | 0.5 mm ² | 20 | 100 | VN01 025 0035 1C | VN02 025 0035 1C | |
| | 0.75 - 1.0 mm ² | 18 | 100 | VN01 025 0036 1C | VN02 025 0036 1C | |
| | 1.5 mm ² | 16 | 100 | VN01 025 0037 1C | VN02 025 0037 1C | |
| | 2.5 mm ² | 14 | 100 | VN01 025 0038 1C | VN02 025 0038 1C | |
| | 4.0 mm ² | 12 | 100 | VN01 025 0039 1C | VN02 025 0039 1C | |
| gold plating | 0.5 mm ² | 20 | 100 | VN01 025 0035 2C | VN02 025 0035 2C | |
| | 0.75 - 1.0 mm ² | 18 | 100 | VN01 025 0036 2C | VN02 025 0036 2C | |
| | 1.5 mm ² | 16 | 100 | VN01 025 0037 2C | VN02 025 0037 2C | |
| | 2.5 mm ² | 14 | 100 | VN01 025 0038 2C | VN02 025 0038 2C | |
| | 4.0 mm ² | 12 | 100 | VN01 025 0039 2C | VN02 025 0039 2C | |

heavy|mate® Q Characteristics contact inserts 7 + PE

| General Characteristics | Standard | Value |
|-------------------------------------|-----------------|---------------------------------------|
| Number of contacts | | 7 + PE |
| Termination technique | | crimp |
| Wire gauge | | 0.14 – 2.5mm ² (AWG 26-14) |
| Flammability | UL94 | V-0 |
| Electrical Characteristics | | |
| Rated voltage | IEC 60664-1 | 400V |
| Pollution degree | IEC 60664-1 | 3 |
| Installation (overvoltage) category | IEC 60664-1 | 3 |
| Material group | IEC 60664-1 | 3b |
| Rated impulse withstand voltage | IEC 60664-1 | 6.0 kV |
| Current carrying capacity | IEC 60512-5-2 | see derating curves |
| Contact resistance | IEC 60512-2-1 | ≤ 5 mΩ |
| Insulation resistance | IEC 60512-3-1 | ≥ 10 ¹⁰ Ω |
| Climatical Characteristics | | |
| Climatic category | IEC 60068-1 | 40/125/21 |
| Upper temperature | IEC 60512-11-9 | +125°C |
| Lower temperature | IEC 60512-11-10 | -40°C |
| Mechanical Characteristics | | |
| Mechanical operation | IEC 60512-9-1 | ≥500 mating cycles |
| Materials | | |
| Insert | | PC |
| Colour insert | | grey |
| Contacts | | Cu-alloy |
| Contact plating | | Ag (silver) /Au (gold) |
| Derating Curves | | |
| In preparation | | |

| Description | Part Number | Drawing | Figure |
|-------------|-------------|---------|--------|
|-------------|-------------|---------|--------|

Contact insert 7 + PE (Please order contacts separately)

| | | | |
|---------------|--------------------|--|--|
| Male insert | C146 10A007 500 12 | | |
| Female insert | C146 10B007 500 12 | | |

Coding element

| | | | |
|---------------|---------------|--|--|
| Male insert | N17 059 000 1 | | |
| Female insert | N17 059 000 2 | | |

Contact arrangement

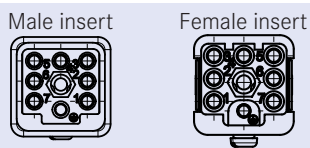

| Supplied as | for wire gauge | AWG | Pieces | Part Number | | Figure |
|-------------|----------------|-----|--------|--------------|----------------|--------|
| | | | | Male contact | Female contact | |

Turned 1.6 mm crimp contacts single contact

| | | | | | | |
|----------------|-----------------------------|-------|-----|------------------|------------------|--|
| silver plating | 0.14 - 0.37 mm ² | 26-22 | 100 | VN01 016 0024 1C | VN02 016 0024 1C | |
| | 0.5 mm ² | 20 | 100 | VN01 016 0025 1C | VN02 016 0025 1C | |
| | 0.75 - 1.0 mm ² | 20-16 | 100 | VN01 016 0026 1C | VN02 016 0026 1C | |
| | 1.5 mm ² | 16-15 | 100 | VN01 016 0027 1C | VN02 016 0027 1C | |
| | 2.5 mm ² | 14 | 100 | VN01 016 0028 1C | VN02 016 0028 1C | |
| gold plating | 0.14 - 0.37 mm ² | 26-22 | 100 | VN01 016 0024 2C | VN02 016 0024 2C | |
| | 0.5 mm ² | 20 | 100 | VN01 016 0025 2C | VN02 016 0025 2C | |
| | 0.75 - 1.0 mm ² | 20-16 | 100 | VN01 016 0026 2C | VN02 016 0026 2C | |
| | 1.5 mm ² | 16-15 | 100 | VN01 016 0027 2C | VN02 016 0027 2C | |
| | 2.5 mm ² | 14 | 100 | VN01 016 0028 2C | VN02 016 0028 2C | |



heavy | mate[®] Housings

Available Types

- Standard-Housings IP65
- Housings in IP67 and IP68
- EMC-Housings
- Corrosion resistant Housings





General information

- The connectors of our heavy|mate® series are designed for use in machine tools, general electric installations and applications as well as for industrial control and other electrical equipment. Other applications than the above mentioned are in the responsibility of the user.
- For cable to cable connections a suitable cable clamp has to be used.
- The indicated dimensions with the panel cut-outs represent reference values and are in the concrete application with products to be co-ordinated.
- The sealing area of the housing has to be level and free of burrs.
- Housings in accordance with DIN EN 175 301 - 801 (DIN 43 652) .

Range of housings

Size A3/4



Size A10



Size A16



Size A32



Size E6



Size E10



Size E16



Size E24











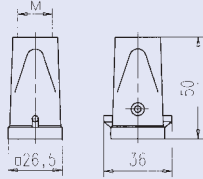

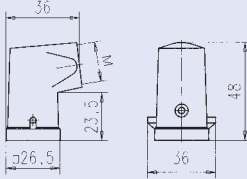

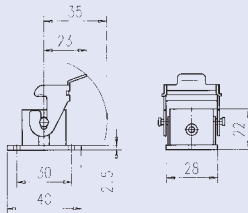

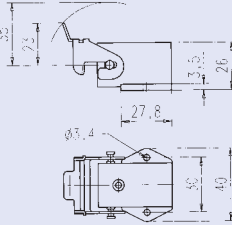
Size E48

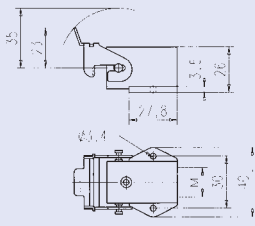

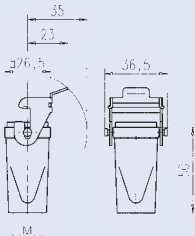
heavy|mate® Housings standard Characteristics

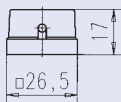









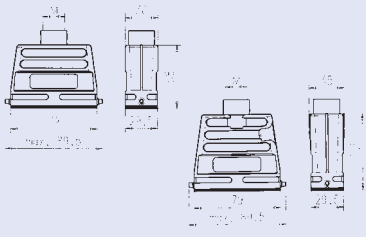
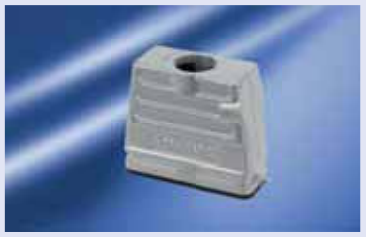
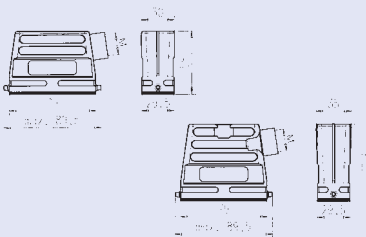

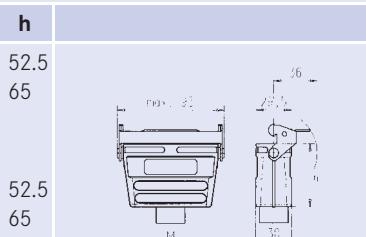

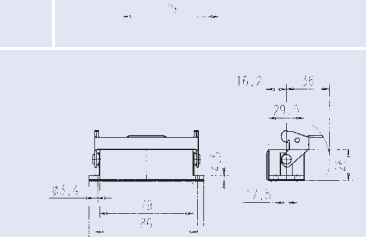
| General Characteristics | Standard | Value |
|--|---------------------------------|-------------------------------------|
| Protection class housing | | IP 65 |
| Protection class spring cover locked spring loaded | | IP 65 IP 54 |
| Locking system | DIN EN 175 301-801 (DIN 43 652) | 1 locking lever 2 locking levers |
| Climatical Characteristics | | |
| Climatic category | IEC 60068-1 | 40 / 125 / 21 |
| Temperature range | IEC 60068-1 | - 40 °C / + 125 °C |
| Upper temperature | IEC 60512-11-9 | + 125 °C |
| Lower temperature | IEC 60512-11-10 | - 40 °C |
| Mechanical Characteristics | | |
| Mechanical operation | IEC 60512-9-1 | ≥ 500 mating cycles |
| Materials | | |
| Housings | DIN EN 175 301-801 (DIN 43 652) | Aluminium die cast alloy |
| Thermoplastic housing | | PA |
| Metal housing D 7 | | Zinc die cast alloy |
| Protective cover | | PA |
| Rubber gasket | | NBR |
| Locking lever | | steel / zinc coated |
| Surface EMV housings | | special surface |

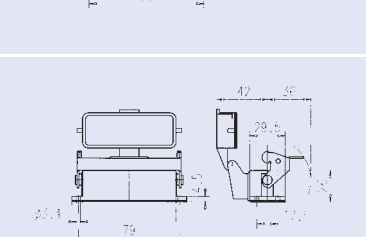
| Description | M | Part Number | Drawing | Figure |
|---|----|-------------------|--|---|
| Hoods | | | | |
| Hood top entry | 20 | C146 10R003 600 4 |  |  |
| Hood side entry | 20 | C146 10R003 500 4 |  |  |
| Housings | | | | |
| Housing bulkhead mounting with gasket | - | C146 10F003 000 4 |  |  |
| Housing bulkhead end mounting with gasket | - | C146 10F003 004 4 |  |  |
| Housing single side entry with gland bushing | 20 | C146 10N003 500 4 |  |  |
| Hood cable to cable coupling | 20 | C146 10R003 804 4 |  |  |
| Protective cover (only in connection with male insert) | | | | |
| Cover for housings | - | C146 10Z003 100 4 |  |  |

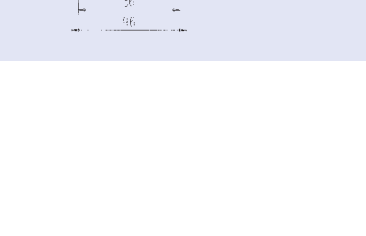
| Description | M | Part Number | Drawing | Figure |
|---|----|-------------------|--|---|
| Hoods | | | | |
| Hood top entry | 20 | C146 30R003 600 4 |  |  |
| Hood side entry | 20 | C146 30R003 500 4 |  |  |
| Housings | | | | |
| Housing bulkhead mounting with gasket | - | C146 30F003 000 4 |  |  |
| Housing bulkhead end mounting with gasket | - | C146 30F003 004 4 |  |  |
| Housing single side entry with gland bushing | 20 | C146 30N003 500 4 |  |  |
| Hood cable to cable coupling | 20 | C146 30R003 804 4 |  |  |
| Protective cover (only in connection with male insert) | | | | |
| Cover for housings | - | C146 30Z003 100 4 |  |  |

heavy|mate® Housings standard Size A10

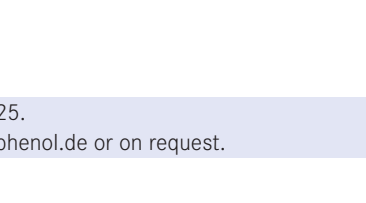
| Description | M | Part Number | Drawing | Figure |
|---|----------|--|---------------------------------|--------|
| Housings | | | | |
| Housing single side entry | 25 | C146 10N015 500 2 | <p>1 closed if single entry</p> | |
| Housing double side entry | 25 | C146 10N015 600 2 | | |
| Housing with spring cover single side entry | 25 | C146 10N015 806 2 | <p>1 closed if single entry</p> | |
| Housing with spring cover double side entry | 20 25 | C146 10N015 607 2 C146 10N015 606 2 | | |
| Protective cover | | | | |
| Cover for housings | - | C146 10Z015 100 2 | | |
| Panel cut out | | | | |
| | | | | |

| Description | M | Part Number | Drawing | Figure | |
|--|----|-------------------|--|---|---|
| Hoods | | | | | |
| Hood top entry low profile | 20 | C146 21R016 650 4 |  |  | |
| | 25 | C146 21R016 600 4 | | | |
| Hood top entry high profile | 20 | C146 21R025 650 2 |  |  | |
| | 25 | C146 21R025 600 2 | | | |
| Hood side entry low profile | 20 | C146 21R016 550 4 |  |  | |
| | 25 | C146 21R016 500 4 | | | |
| Hood side entry high profile | 20 | C146 21R025 550 2 |  |  | |
| | 25 | C146 21R025 500 2 | | | |
| Housings | | | h | | |
| Hood coupling application low profile | 20 | C146 21R016 854 4 |  | 52.5 65 |  |
| | 25 | C146 21R016 804 4 | | | |
| Hood coupling application high profile | 20 | C146 21R025 854 2 |  | 52.5 65 |  |
| | 25 | C146 21R025 804 2 | | | |
| Housing bulkhead mounting with gasket | - | C146 10F025 000 2 |  | |  |
| Housing bulkhead mounting with spring cover with gasket | - | C146 10F025 003 2 |  | |  |

heavy|mate® Housings standard Size A16

| Description | M | Part Number | Drawing | Figure |
|---|----------|--|---------------------------------|--------|
| Housings | | | | |
| Housing single side entry | 25 | C146 10N025 500 2 | <p>1 closed if single entry</p> | |
| Housing double side entry | 20 25 | C146 10N025 601 2 C146 10N025 600 2 | | |
| Housing with spring cover single side entry | 25 | C146 10N025 806 2 | <p>1 closed if single entry</p> | |
| Housing with spring cover double side entry | 20 25 | C146 10N025 607 2 C146 10N025 606 2 | | |
| Protective cover | | | | |
| Cover for housings | - | C146 10Z025 100 2 | | |

Panel cut out









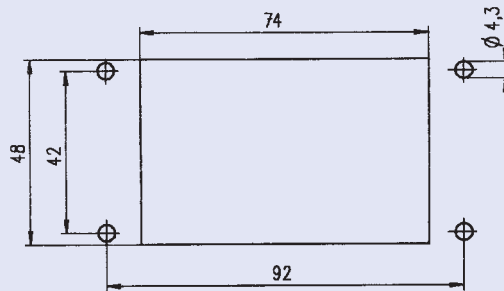



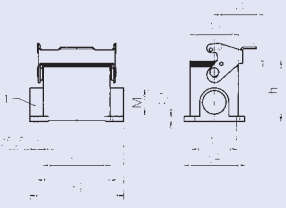

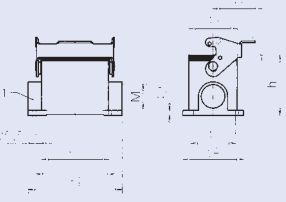
| Description | M | Part Number | Drawing | Figure |
|---------------------------|----------|--|---------|--------|
| Hoods | | | | |
| Hood top entry | 25 32 | C146 21R032 650 4 C146 21R032 600 4 | | |
| Hood side entry | 25 32 | C146 21R032 550 4 C146 21R032 500 4 | | |
| Hood coupling application | 25 32 | C146 21R032 852 4 C146 21R032 802 4 | | |
| Hood top entry | 25 32 | C146 21R032 652 4 C146 21R032 602 4 | | |
| Hood side entry | 25 32 | C146 21R032 552 4 C146 21R032 502 4 | | |

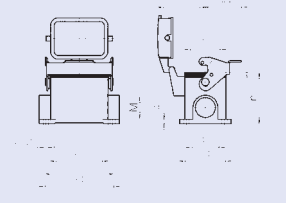
| Description | M | Part Number | Drawing | Figure |
|---------------------------------------|----------|--|---------|--------|
| Housings | | | | |
| Housing bulkhead mounting with gasket | - | C146 10F032 000 4 | | |
| Housing single side entry | 25 32 | C146 10N032 550 4 C146 10N032 500 4 | | |
| Housing double side entry | 25 32 | C146 10N032 650 4 C146 10N032 600 4 | | |

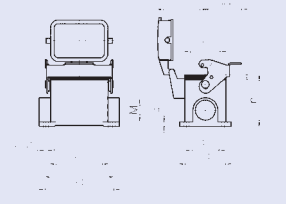
Panel cut out

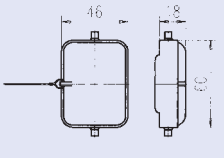

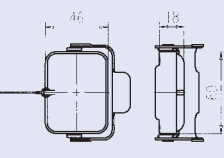
| Description | M | Part Number | Drawing | Figure | |
|---|----|-------------------|----------|--------|--|
| Hoods | | | | | |
| Hood top entry low profile | 16 | C146 21R006 656 1 | | | |
| | 20 | C146 21R006 606 1 | | | |
| Hood top entry high profile | 25 | C146 21R006 656 8 | | | |
| | 32 | C146 21R006 606 8 | | | |
| Hood side entry low profile | 20 | C146 21R006 506 1 | | | |
| | 25 | C146 21R006 507 1 | | | |
| Hood side entry high profile | 25 | C146 21R006 556 8 | | | |
| | 32 | C146 21R006 506 8 | | | |
| Housings | | | h | | |
| Hood coupling application low profile | 20 | C146 21R006 804 1 | 52 | | |
| Hood coupling application high profile | 25 | C146 21R006 854 8 | 70 | | |
| Housing bulkhead mounting with gasket | - | C146 10F006 000 1 | | | |
| Housing bulkhead mounting with thermoplastic spring cover with gasket | - | C146 10F006 003 1 | | | |
| Housing bulkhead mounting with metal spring cover with gasket | - | C146 30F006 003 1 | | | |

| Description | M | Part Number | Drawing | Figure |
|---|----------|--|---|---|
| Housings | | | | |
| Housing single side entry low profile | 20 | C146 10N006 803 1 |  <p>1 closed if single entry</p> |  |
| Housing single side entry high profile | 32 | C146 10N006 802 2 | | |
| Housing double side entry low profile | 20 | C146 10N006 603 1 |  |  |
| Housing double side entry high profile | 25 32 | C146 10N006 603 2 C146 10N006 602 2 | | |
| Housing with spring cover single side entry low profile | 20 25 | C146 10N006 807 1 C146 10N006 806 1 |  <p>1 closed if single entry</p> |  |
| Housing with spring cover single side entry high profile | 25 32 | C146 10N006 807 2 C146 10N006 806 2 | | |
| Housing with spring cover double side entry low profile | 20 | C146 10N006 607 1 |  |  |
| Housing with spring cover double side entry high profile | 25 32 | C146 10N006 607 2 C146 10N006 606 2 | | |
| Protective cover | | | | |
| Cover for housings | - | C146 10Z006 100 1 |  |  |
| Cover for hoods | - | C146 10Z006 200 1 |  |  |

Panel cut out

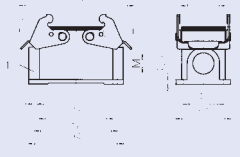
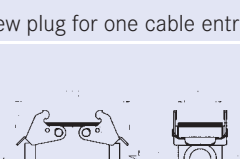
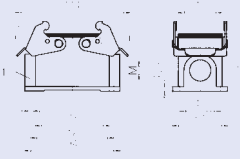
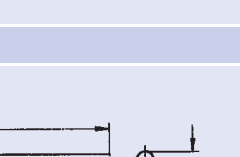

| Description | M | Part Number | Drawing | Figure |
|--|----|-------------------|----------|--------|
| Hoods | | | | |
| Hood top entry low profile | 20 | C146 21R010 650 1 | | |
| | 25 | C146 21R010 600 1 | | |
| Hood top entry high profile | 25 | C146 21R010 650 8 | | |
| | 32 | C146 21R010 600 8 | | |
| Hood side entry low profile | 20 | C146 21R010 550 1 | | |
| | 25 | C146 21R010 500 1 | | |
| Hood side entry high profile | 25 | C146 21R010 550 8 | | |
| | 32 | C146 21R010 500 8 | | |
| Housings | | | h | |
| Hood coupling application low profile | 20 | C146 21R010 852 1 | | |
| | 25 | C146 21R010 802 1 | | |
| Hood coupling application high profile | 25 | C146 21R010 852 8 | | |
| | 32 | C146 21R010 802 8 | | |
| Housing bulkhead mounting with gasket | - | C146 10F010 000 1 | | |
| Right-angled housing with gasket | - | C146 10F010 090 1 | | |

| Description | M | Part Number | Drawing | Drawing |
|--|----|-------------------|--------------------------------|--|
| Housings | | | h | |
| Housing single side entry low profile | 20 | C146 10N010 501 1 | 57 |  |
| | 25 | C146 10N010 500 1 | 57 | |
| Housing single side entry high profile | 25 | C146 10N010 501 2 | 74 |  |
| | 32 | C146 10N010 500 2 | 74 | |
| | | | Screw plug for one cable entry | |
| Housing double side entry low profile | 20 | C146 10N010 601 1 | 57 |  |
| | 25 | C146 10N010 601 2 | 74 | |
| Housing double side entry high profile | 32 | C146 10N010 600 2 | 74 |  |
| | | | | |





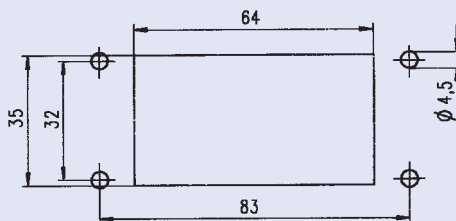



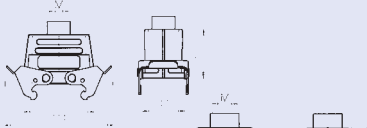

Panel cut out

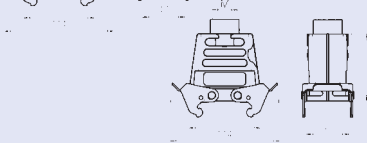

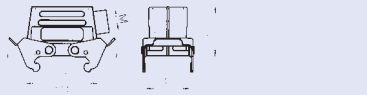
| Description | M | Part Number | Drawing | Figure |
|---|----|-------------------|----------|--------|
| Hoods | | | | |
| Hood top entry low profile | 20 | C146 21R010 656 1 | | |
| | 25 | C146 21R010 606 1 | | |
| | 32 | C146 21R010 607 1 | | |
| Hood top entry high profile | 25 | C146 21R010 656 8 | | |
| | 32 | C146 21R010 606 8 | | |
| | 40 | C146 21R010 607 8 | | |
| Hood side entry low profile | 20 | C146 21R010 556 1 | | |
| | 25 | C146 21R010 506 1 | | |
| Hood side entry high profile | 25 | C146 21R010 556 8 | | |
| | 32 | C146 21R010 506 8 | | |
| Housings | | | h | |
| Hood coupling application low profile | 20 | C146 21R010 854 1 | | |
| | 25 | C146 21R010 804 1 | | |
| | 32 | C146 21R010 805 1 | | |
| Hood coupling application high profile | 25 | C146 21R010 854 8 | | |
| | 32 | C146 21R010 804 8 | | |
| | 40 | C146 21R010 805 8 | | |
| Housing bulkhead mounting with gasket | - | C146 10F010 001 1 | | |
| Housing bulkhead mounting with thermoplastic spring cover with gasket | - | C146 10F010 003 1 | | |
| Housing bulkhead mounting with metal spring cover with gasket | - | C146 30F010 003 1 | | |

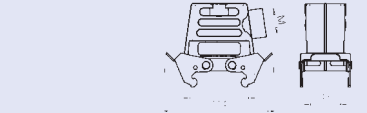
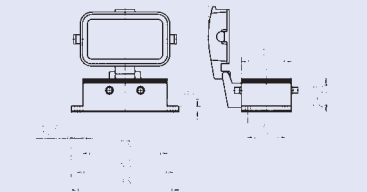
| Description | M | Part Number | Drawing | Figure |
|---|----------|--|--|---|
| Housings | | | | |
| Housing single side entry low profile | 20 | C146 10N010 803 1 | 57  |  |
| Housing single side entry high profile | 25 32 | C146 10N010 803 2 C146 10N010 802 2 | 74 74 1 closed if single entry | |
| Housing double side entry low profile | 20 | C146 10N010 603 1 | 57  |  |
| Housing double side entry high profile | 25 | C146 10N010 603 2 | 74  | |
| Housing with spring cover single side entry low profile | 20 | C146 10N010 807 1 | 57  |  |
| Housing with spring cover single side entry high profile | 25 32 | C146 10N010 807 2 C146 10N010 806 2 | 74 74 1 closed if single entry | |
| Housing with spring cover double side entry low profile | 20 | C146 10N010 607 1 | 57  |  |
| Housing with spring cover double side entry high profile | 25 32 | C146 10N010 607 2 C146 10N010 606 2 | 74 74 | |

| Description | M | Part Number | Drawing | Figure |
|---|----------|--|---|--|
| Hoods | | | | |
| Hood top entry low profile | 20 | C146 21R010 652 1 |  |  |
| Hood top entry high profile | 25 32 | C146 21R010 652 8 C146 21R010 602 8 |  |  |
| Hood side entry low profile | 20 | C146 21R010 552 1 |  |  |
| Hood side entry high profile | 25 32 | C146 21R010 552 8 C146 21R010 502 8 |  | |
| Housings | | | | |
| Housing with spring cover with gasket | - | C146 10F010 002 1 |  |  |

| Description | M | Part Number | Drawing | Figure |
|---|----|-------------------|--------------------------|---|
| Housings | | | h | |
| Housing single side entry low profile | 20 | C146 10N010 509 1 | 57 |  |
| Housing single side entry high profile | 32 | C146 10N010 508 2 | 74 | |
| | | | 1 closed if single entry | |
| Housing double side entry low profile | 20 | C146 10N010 609 1 | 57 |  |
| Housing double side entry high profile | 25 | C146 10N010 609 2 | 74 | |
| Housing with spring cover single side entry low profile | 20 | C146 10N010 805 1 | 57 |  |
| Housing with spring cover single side entry high profile | 32 | C146 10N010 804 2 | 74 | |
| | | | 1 closed if single entry | |
| Housing with spring cover double side entry low profile | 20 | C146 10N010 605 1 | 57 |  |
| Housing with spring cover double side entry high profile | 32 | C146 10N010 604 2 | 74 | |

| Description | M | Part Number | Drawing | Figure |
|---|----|-------------------|---------|--------|
| Hoods | | | | |
| Hood 2 top entry high profile | 25 | C146 10R010 902 8 | | |
| Protective cover (only in connection with male insert) | | | | |
| Cover for housings | - | C146 10Z010 100 1 | | |
| Cover for hoods | - | C146 10Z010 200 1 | | |
| Further special housings on request. | | | | |

| Description | M | Part Number | Drawing | Figure |
|--|----------|--|--------------------------|--------|
| Hoods | | | | |
| Hood top entry low profile | 25 | C146 21R016 650 1 | | |
| | 32 | C146 21R016 600 1 | | |
| Hood top entry high profile | 32 | C146 21R016 600 8 | | |
| | 40 | C146 21R016 601 8 | | |
| Hood side entry low profile | 25 | C146 21R016 550 1 | | |
| | 32 | C146 21R016 500 1 | | |
| Hood side entry high profile | 32 | C146 21R016 500 8 | | |
| | 40 | C146 21R016 501 8 | | |
| Housings | | | h | |
| Hood coupling application low profile | 25 | C146 21R016 852 1 | | |
| | 32 | C146 21R016 802 1 | | |
| Hood coupling application high profile | 32 | C146 21R016 802 8 | | |
| | 40 | C146 21R016 803 8 | | |
| Housing bulkhead mounting with gasket | - | C146 10F016 000 1 | | |
| Housing single side entry low profile | 25 | C146 10N016 500 1 | | |
| Housing single side entry high profile | 32 | C146 10N016 500 2 | | |
| | | | 1 closed if single entry | |
| Housing double side entry low profile | 25 | C146 10N016 600 1 | | |
| Housing double side entry high profile | 25 32 | C146 10N016 601 2 C146 10N016 600 2 | | |

Panel cut out



| Description | M | Part Number | Drawing | Figure |
|---|----|-------------------|--|---|
| Hoods | | | | |
| Hood top entry low profile | 25 | C146 21R016 656 1 |  |  |
| | 32 | C146 21R016 606 1 | | |
| Hood top entry high profile | 32 | C146 21R016 606 8 |  | |
| | 40 | C146 21R016 607 8 | | |
| Hood side entry low profile | 25 | C146 21R016 556 1 |  |  |
| | 32 | C146 21R016 506 1 | | |
| Hood side entry high profile | 32 | C146 21R016 506 8 |  | |
| | 40 | C146 21R016 507 8 | | |
| Housings | | | h | |
| Hood coupling application low profile | 25 | C146 21R016 854 1 |  |  |
| | 32 | C146 21R016 804 1 | | |
| Hood coupling application high profile | 32 | C146 21R016 804 8 |  |  |
| | 40 | C146 21R016 805 8 | | |
| Housing bulkhead mounting with gasket | - | C146 10F016 001 1 |  |  |
| Housing bulkhead mounting with thermoplastic spring cover with gasket | - | C146 10F016 003 1 |  |  |
| Housing bulkhead mounting with metal spring cover with gasket | - | C146 30F016 003 1 |  |  |

| Description | M | Part Number | Drawing | Figure |
|---|----------|--|----------|---|
| Housings | | | | |
| Housing single side entry low profile | 25 | C146 10N016 802 1 | 64 |  |
| Housing single side entry high profile | 32 | C146 10N016 802 2 | 77 | |
| Housing double side entry low profile | 25 | C146 10N016 602 1 | 64 |  |
| Housing double side entry high profile | 25 32 | C146 10N016 603 2 C146 10N016 602 2 | 77 77 | |
| Housing with spring cover single side entry low profile | 25 | C146 10N016 806 1 | 64 |  |
| Housing with spring cover single side entry high profile | 32 | C146 10N016 806 2 | 77 | |
| Housing with spring cover double side entry low profile | 25 | C146 10N016 606 1 | 64 |  |
| Housing with spring cover double side entry high profile | 25 32 | C146 10N016 607 2 C146 10N016 606 2 | 77 77 | |

1 closed if single entry

1 closed if single entry

| Description | M | Part Number | Drawing | Figure |
|--|----|-------------------|---|--|
| Hoods | | | | |
| Hood top entry low profile | 25 | C146 21R016 652 1 |  |  |
| | 32 | C146 21R016 602 1 | | |
| Hood top entry high profile | 32 | C146 21R016 602 8 |  | |
| | 40 | C146 21R016 603 8 | | |
| Hood side entry low profile | 25 | C146 21R016 552 1 |  |  |
| | 32 | C146 21R016 502 1 | | |
| Hood side entry high profile | 32 | C146 21R016 502 8 |  | |
| | 40 | C146 21R016 503 8 | | |
| Housings | | | | |
| Housing bulkhead mounting with spring cover with gasket | - | C146 10F016 002 1 |  |  |

| Description | M | Part Number | Drawing | Figure |
|---|----|-------------------|--------------------------|---|
| Housings | | | h | |
| Housing single side entry low profile | 25 | C146 10N016 508 1 | 64 |  |
| Housing single side entry high profile | 32 | C146 10N016 508 2 | 77 | |
| | | | 1 closed if single entry | |
| Housing double side entry low profile | 25 | C146 10N016 608 1 | 64 |  |
| Housing double side entry high profile | 32 | C146 10N016 608 2 | 77 | |
| Housing with spring cover single side entry low profile | 25 | C146 10N016 804 1 | 64 |  |
| Housing with spring cover single side entry high profile | 32 | C146 10N016 804 2 | 77 | |
| | | | 1 closed if single entry | |
| Housing with spring cover double side entry low profile | 25 | C146 10N016 604 1 | 64 |  |
| Housing with spring cover double side entry high profile | 32 | C146 10N016 604 2 | 77 | |

| Description | M | Part Number | Drawing | Figure |
|---|----------|--|---------|--------|
| Hoods | | | | |
| Hood 2 top entry high profile | 25 32 | C146 10R016 910 8 C146 10R016 902 8 | | |
| Protective cover (only in connection with male insert) | | | | |
| Cover for housings | - | C146 10Z016 200 1 | | |
| Cover for hoods | - | C146 10Z016 100 1 | | |
| Further special housings on request. | | | | |







| Description | M | Part Number | Drawing | Figure |
|--|----|-------------------|--------------------------|--------|
| Hoods | | | | |
| Hood top entry low profile | 25 | C146 21R024 650 1 | | |
| | 32 | C146 21R024 600 1 | | |
| Hood top entry high profile | 32 | C146 21R024 600 8 | | |
| | 40 | C146 21R024 601 8 | | |
| Hood side entry low profile | 25 | C146 21R024 550 1 | | |
| | 32 | C146 21R024 500 1 | | |
| Hood side entry high profile | 32 | C146 21R024 500 8 | | |
| | 40 | C146 21R024 501 8 | | |
| Housings | | | h | |
| Hood coupling application low profile | 25 | C146 21R024 852 1 | | |
| | 32 | C146 21R024 802 1 | | |
| Hood coupling application high profile | 32 | C146 21R024 802 8 | | |
| | 40 | C146 21R024 803 8 | | |
| Housing bulkhead mounting with gasket | - | C146 10F024 000 1 | | |
| Housing single side entry low profile | 25 | C146 10N024 500 1 | | |
| Housing single side entry high profile | 32 | C146 10N024 500 2 | | |
| | | | 1 closed if single entry | |
| Housing double side entry low profile | 25 | C146 10N024 600 1 | | |
| Housing double side entry high profile | 25 | C146 10N024 601 2 | | |
| | 32 | C146 10N024 600 2 | | |

Panel cut out

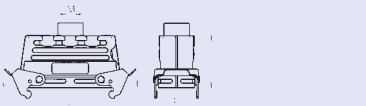

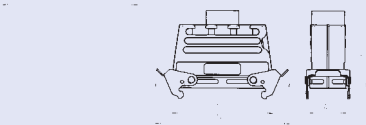
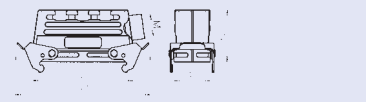
| Description | M | Part Number | Drawing | Figure |
|---|----|-------------------|--|---|
| Hoods | | | | |
| Hood top entry low profile | 25 | C146 21R024 656 1 |  |  |
| | 32 | C146 21R024 606 1 | | |
| Hood top entry high profile | 32 | C146 21R024 606 8 |  |  |
| | 40 | C146 21R024 607 8 | | |
| Hood side entry low profile | 25 | C146 21R024 556 1 |  |  |
| | 32 | C146 21R024 506 1 | | |
| Hood side entry high profile | 32 | C146 21R024 506 8 |  |  |
| | 40 | C146 21R024 507 8 | | |
| Housings | | | h | |
| Hood coupling application low profile | 25 | C146 21R024 854 1 |  |  |
| | 32 | C146 21R024 804 1 | | |
| Hood coupling application high profile | 32 | C146 21R024 804 8 |  |  |
| | 40 | C146 21R024 805 8 | | |
| Housing bulkhead mounting with gasket | - | C146 10F024 001 1 |  |  |
| Housing bulkhead mounting with thermoplastic spring cover with gasket | - | C146 10F024 003 1 |  |  |
| Housing bulkhead mounting with metal spring cover with gasket | - | C146 30F024 003 1 |  |  |

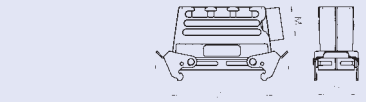
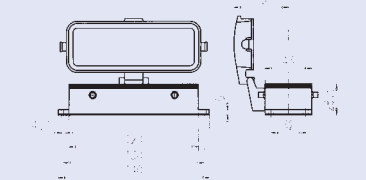
| Description | M | Part Number | Drawing | Figure |
|---|----|--|--------------------------|---|
| Hoods | | | h | |
| Housing single side entry low profile | 25 | C146 10N024 802 1 | 64 |  |
| Housing single side entry high profile | 32 | C146 10N024 802 2 | 80 | |
| | | | 1 closed if single entry | |
| Housing double side entry low profile | 25 | C146 10N024 602 1 | 64 |  |
| Housing double side entry high profile | 32 | C146 10N024 602 2 | 80 | |
| Housing with spring cover single side entry low profile | 25 | C146 10N024 806 1 | 64 |  |
| Housing with spring cover single side entry high profile | 32 | C146 10N024 806 2 | 80 | |
| | | | 1 closed if single entry | |
| Housing with spring cover double side entry low profile | 25 | C146 10N024 606 1 | 64 |  |
| Housing with spring cover double side entry high profile | 32 | C146 10N024 607 2 C146 10N024 606 2 | 80 80 | |

| Description | M | Part Number | Drawing | Figure |
|--|----|-------------------|---|--|
| Hoods | | | | |
| Hood top entry low profile | 25 | C146 21R024 652 1 |  |  |
| | 32 | C146 21R024 602 1 | | |
| Hood top entry high profile | 32 | C146 21R024 602 8 |  | |
| | 40 | C146 21R024 603 8 | | |
| Hood side entry low profile | 25 | C146 21R024 552 1 |  |  |
| | 32 | C146 21R024 502 1 | | |
| Hood side entry high profile | 32 | C146 21R024 502 8 |  | |
| | 40 | C146 21R024 503 8 | | |
| Housings | | | | |
| Housing bulkhead mounting with spring cover with gasket | - | C146 10F024 002 1 |  |  |

| Description | M | Part Number | Drawing | Figure |
|---|----|-------------------|--------------------------|---|
| Housings | | | | |
| Housing single side entry low profile | 25 | C146 10N024 508 1 | 64 |  |
| Housing single side entry high profile | 32 | C146 10N024 508 2 | 80 | |
| | | | 1 closed if single entry | |
| Housing double side entry low profile | 25 | C146 10N024 608 1 | 64 |  |
| Housing double side entry high profile | 32 | C146 10N024 608 2 | 80 | |
| | | | 1 closed if single entry | |
| Housing with spring cover single side entry low profile | 25 | C146 10N024 804 1 | 64 |  |
| Housing with spring cover single side entry high profile | 32 | C146 10N024 804 2 | 80 | |
| | | | 1 closed if single entry | |
| Housing with spring cover double side entry low profile | 25 | C146 10N024 604 1 | 64 |  |
| Housing with spring cover double side entry high profile | 32 | C146 10N024 604 2 | 80 | |
| | | | 1 closed if single entry | |

| Description | M | Part Number | Drawing | Figure |
|---|----------|--|---|--|
| Hoods | | | | |
| Hood 2 top entry high profile | 32 40 | C146 10R024 903 8 C146 10R024 908 8 |  |  |
| Protective cover (only in connection with male insert) | | | | |
| Cover for housings | - | C146 10Z024 200 1 |  |  |
| Cover for hoods | - | C146 10Z024 100 1 |  |  |
| Further special housings on request. | | | | |

| Description | M | Part Number | Drawing | Figure |
|------------------------------------|----------|--|--|---|
| Hoods | | | | |
| Hood top entry low profile | 40 50 | C146 21R048 607 1 C146 21R048 608 1 |  |  |
| Hood top entry high profile | | | | |
| Hood side entry low profile | 40 50 | C146 21R048 507 1 C146 21R048 508 1 |  |  |
| Hood side entry high profile | | | | |

| Description | M | Part Number | Drawing | Figure |
|---|----|-------------------|--|---|
| Hoods | | | | |
| Housing bulkhead mounting with gasket | - | C146 10F048 001 1 |  |  |
| Housing bulkhead mounting with spring cover with gasket | - | C146 10F048 003 1 |  |  |
| Housing single side entry | 40 | C146 10N048 803 1 |  |  |
| Housing with spring cover | 40 | C146 10N048 807 1 |  |  |

Panel cut out



| Description | M | Part Number | Drawing | Figure |
|---|----|-------------------|---------------------------------|--------|
| Hoods | | | | |
| Hood top entry low profile | 25 | C146 10R024 650 3 | | |
| | 32 | C146 10R024 600 3 | | |
| Hood side entry low profile | 25 | C146 10R024 550 3 | | |
| | 32 | C146 10R024 500 3 | | |
| Housings | | | | |
| Hood coupling application low profile | 25 | C146 10R024 852 3 | | |
| | 32 | C146 10R024 802 3 | | |
| Housing bulkhead mounting with gasket | - | C146 10F024 000 3 | | |
| Housing single side entry low profile | 25 | C146 10N024 500 3 | <p>1 closed if single entry</p> | |
| Housing double side entry low profile | 25 | C146 10N024 600 3 | | |

Panel cut out



heavy|mate® Housings IP 67 Characteristics

| General Characteristics | Standard | Value |
|----------------------------|-----------------|--------------------------|
| Protection class housing | | IP 67 |
| Locking system | | 2 locking levers |
| Climatical Characteristics | | |
| Climatic category | IEC 60068-1 | 40 / 125 / 21 |
| Temperature range | IEC 60068-1 | - 40 °C / + 125 °C |
| Upper temperature | IEC 60512-11-9 | + 125 °C |
| Lower temperature | IEC 60512-11-10 | - 40 °C |
| Mechanical Characteristics | | |
| Mechanical operation | IEC 60512-9-1 | ≥ 500 mating cycles |
| Materials | | |
| Housings | | Aluminium die cast alloy |
| Colour housings | | grey |
| Rubber gasket | | CR |
| Locking lever | | steel / zinc coated |
| Surface | | powder coating |







heavy|mate® Housings IP 67 Size E6

| Description | M | Part Number | Drawing | Figure | |
|--|----|-------------------|-----------|-----------|--|
| Hoods | | | | | |
| Hood top entry | 25 | C146 67R006 607 1 | | | |
| Hood side entry | 25 | C146 67R006 507 1 | | | |
| Housings | | | L1 | L2 | |
| Housing bulkhead mounting | | C146 67F006 000 8 | 70 | 80 | |
| | | | | | |
| Panel cut out | | | | | |
| <p style="text-align: center;">Version A + B</p> | | | | | |

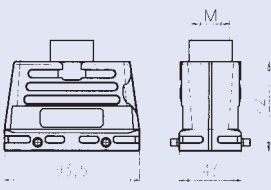

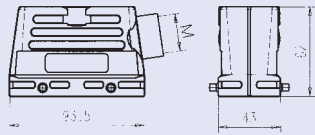

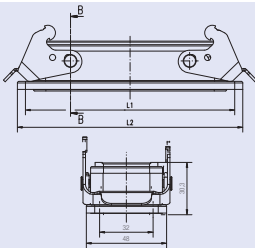

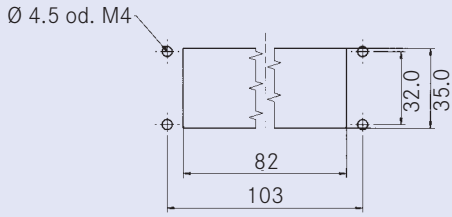
heavy|mate® Housings IP 67 Size E10

| Description | M | Part Number | Drawing | Figure |
|---------------------------|----|-------------------|-----------|-----------|
| Hoods | | | | |
| Hood top entry | 25 | C146 67R010 600 1 | | |
| Hood side entry | 25 | C146 67R010 500 1 | | |
| Housings | | | L1 | L2 |
| Housing bulkhead mounting | | C146 67F010 000 8 | 83 | 93 |
| | | | | |
| Panel cut out | | | | |
| <p>Version A + B</p> | | | | |

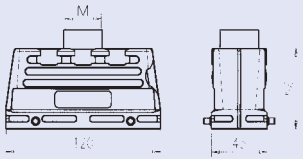
heavy|mate® Housings IP 67 Size E16

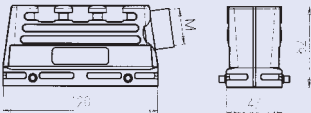
| Description | M | Part Number | Drawing | Figure | |
|--|-------------------|-------------------|--|---|--|
| Hoods | | | | | |
| Hood top entry | 32 | C146 67R016 600 8 |  |  | |
| Hood side entry | 32 | C146 67R016 500 8 |  |  | |
| Housings | | | L1 | L2 | |
| Housing bulkhead mounting | C146 67F016 000 8 | 103 | 113 |  |  |
| Panel cut out | | | | | |
|  <p>Version A + B</p> | | | | | |

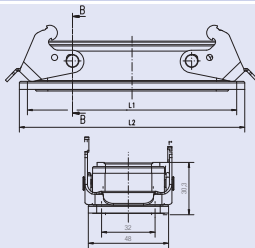
heavy|mate® Housings IP 67 Size E24

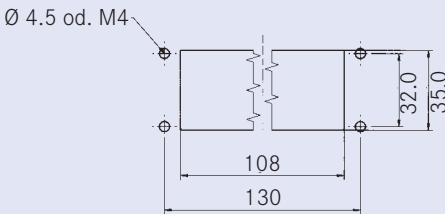
| Description | M | Part Number | Drawing | Figure |
|--|----|-------------------|---|--|
| Hoods | | | | |
| Hood top entry | 40 | C146 67R024 601 8 |  |  |
| Hood side entry | 40 | C146 67R024 501 8 |  |  |
| Housings | | | L1 | L2 |
| Housing bulkhead mounting | | C146 67F024 000 8 | 130 | 140 |
| | | |  |  |
| Panel cut out | | | | |
|  <p>Version A + B</p> | | | | |

heavy|mate® Housings IP 68 Characteristics

| General Characteristics | Standard | Value |
|----------------------------|-----------------|--------------------------|
| Protection class housing | | IP 68 / IP69K |
| Locking system | | screw M6 |
| Climatical Characteristics | | |
| Climatic category | IEC 60068-1 | 40 / 125 / 21 |
| Temperature range | IEC 60068-1 | - 40 °C / + 125 °C |
| Upper temperature | IEC 60512-11-9 | + 125 °C |
| Lower temperature | IEC 60512-11-10 | - 40 °C |
| Mechanical Characteristics | | |
| Mechanical operation | IEC 60512-9-1 | ≥ 500 mating cycles |
| Materials | | |
| Housings | | Aluminium die cast alloy |
| Colour housings | | black, RAL 9005 |
| Rubber gasket | | NBR |
| Locking lever | | stainless steel |
| Surface | | powder coating |

| Description | M | Part Number | Drawing | Figure |
|---------------------------|----|-------------------|---------|---|
| Hoods | | | | |
| Hood top entry | 32 | C146 68R006 600 8 | |  |
| Hood side entry | 32 | C146 68R006 500 8 | |  |
| Housings | | | | |
| Housing bulkhead mounting | | C146 68F006 001 1 | |  |
| Housing | 32 | C146 68N006 500 2 | |  |

Panel cut out

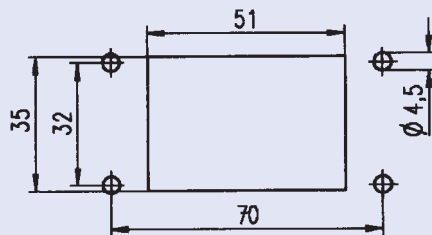

heavy|mate® Housings IP 68 Size 10

| Description | M | Part Number | Drawing | Figure |
|---------------------------|----|-------------------|---------|---|
| Hoods | | | | |
| Hood top entry | 32 | C146 68R010 600 8 | |  |
| Hood side entry | 32 | C146 68R010 500 8 | |  |
| Housings | | | | |
| Housing bulkhead mounting | | C146 68F010 001 1 | |  |
| Housing | 32 | C146 68N010 500 2 | |  |

Panel cut out



heavy|mate® Housings IP 68 Size 16

| Description | M | Part Number | Drawing | Figure |
|---------------------------|----|-------------------|---------|---|
| Hoods | | | | |
| Hood top entry | 40 | C146 68R016 601 8 | |  |
| Hood side entry | 40 | C146 68R016 501 8 | |  |
| Housings | | | | |
| Housing bulkhead mounting | | C146 68F016 001 1 | |  |
| Housing | 32 | C146 68N016 501 2 | |  |

Panel cut out



| Description | M | Part Number | Drawing | Figure |
|---------------------------|----|-------------------|---------|---|
| Hoods | | | | |
| Hood top entry | 40 | C146 68R024 601 8 | |  |
| Hood side entry | 40 | C146 68R024 501 8 | |  |
| Housings | | | | |
| Housing bulkhead mounting | | C146 68F024 001 1 | |  |
| Housing | 32 | C146 68N024 501 2 | |  |

Panel cut out

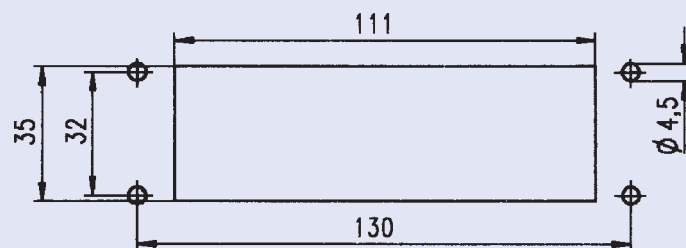

General information

- conductive surface
- standard locking levers
- same housing dimensions like standard housings
- two housing sizes
- with or without ground strap
- high attenuation
- protection class IP 65
- mating cycles > 500



Concept



Range of housings in two housing sizes

Version A
Standard flange without ground strap



Version B
Standard flange with ground strap



Version C
Centering flange with ground strap



heavy|mate® Housings EMC Characteristics

| General Characteristics | Standard | Value |
|----------------------------|-----------------|----------------------------|
| Protection class housing | | IP 65 |
| Locking system | | 2 locking levers |
| Climatical Characteristics | | |
| Climatic category | IEC 60068-1 | 40 / 125 / 21 |
| Temperature range | IEC 60068-1 | - 40 °C / + 125 °C |
| Upper temperature | IEC 60512-11-9 | + 125 °C |
| Lower temperature | IEC 60512-11-10 | - 40 °C |
| Mechanical Characteristics | | |
| Mechanical operation | IEC 60512-9-1 | ≥ 500 mating cycles |
| Materials | | |
| Housings | | Aluminium die cast alloy |
| Colour housings | | grey, RAL 9005 |
| Rubber gasket | | EPDM |
| Locking lever | | steel / zinc coated |
| Surface | | conducting special surface |

| Description | M | Part Number | Drawing | Figure |
|--|----|-------------------|---------|--------|
| Hoods | | | | |
| Hood top entry low profile | 20 | C146 11R006 606 1 | | |
| | 25 | C146 11R006 607 1 | | |
| Hood top entry high profile | 25 | C146 11R006 656 8 | | |
| | 32 | C146 11R006 606 8 | | |
| Hood side entry low profile | 16 | C146 11R006 556 1 | | |
| | 20 | C146 11R006 506 1 | | |
| | 25 | C146 11R006 507 1 | | |
| Hood side entry high profile | 25 | C146 11R006 556 8 | | |
| | 32 | C146 11R006 506 8 | | |
| Housings | | | | |
| Housing bulkhead mounting Version A Standard flange without ground strap | | C146 11F006 901 8 | | |
| Housing bulkhead mounting Version B Standard flange with ground strap | | C146 11F006 902 8 | | |
| Housing bulkhead mounting Version C Centering flange with ground strap | | C146 11F006 001 8 | | |

Panel cut out



Version A + B



Version C

| Description | M | Part Number | Drawing | Figure |
|--|----------------|---|---------|--------|
| Hoods | | | | |
| Hood top entry low profile | 20 25 32 | C146 11R010 650 1 C146 11R010 600 1 C146 11R010 601 1 | | |
| Hood top entry high profile | 25 32 40 | C146 11R010 650 8 C146 11R010 600 8 C146 11R010 601 8 | | |
| Hood side entry low profile | 20 25 | C146 11R010 550 1 C146 11R010 500 1 | | |
| Hood side entry high profile | 25 32 | C146 11R010 550 8 C146 11R010 500 8 | | |
| Housings | | | | |
| Housing bulkhead mounting Version A Standard flange without ground strap | | C146 11F010 901 8 | | |
| Housing bulkhead mounting Version B Standard flange with ground strap | | C146 11F010 902 8 | | |
| Housing bulkhead mounting Version C Centering flange with ground strap | | C146 11F010 000 8 | | |
| Panel cut out | | | | |
| <p>Version A + B</p> | | <p>Version C</p> | | |

| Description | M | Part Number | Drawing | Figure |
|--|----|-------------------|---------|--------|
| Hoods | | | | |
| Hood top entry low profile | 25 | C146 11R016 650 1 | | |
| | 32 | C146 11R016 600 1 | | |
| Hood top entry high profile | 25 | C146 11R016 650 8 | | |
| | 32 | C146 11R016 600 8 | | |
| | 40 | C146 11R016 601 8 | | |
| Hood side entry low profile | 25 | C146 11R016 500 1 | | |
| | 32 | C146 11R016 501 1 | | |
| Hood side entry high profile | 25 | C146 11R016 550 8 | | |
| | 32 | C146 11R016 500 8 | | |
| | 40 | C146 11R016 501 8 | | |
| Housings | | | | |
| Housing bulkhead mounting Version A Standard flange without ground strap | | C146 11F016 901 8 | | |
| Housing bulkhead mounting Version B Standard flange with ground strap | | C146 11F016 902 8 | | |
| Housing bulkhead mounting Version C Centering flange with ground strap | | C146 11F016 000 8 | | |

Panel cut out



Version A + B



Version C

| Description | M | Part Number | Drawing | Figure |
|--|----|-------------------|---------|--------|
| Hoods | | | | |
| Hood top entry low profile | 25 | C146 11R024 650 1 | | |
| | 32 | C146 11R024 600 1 | | |
| Hood top entry high profile | 25 | C146 11R024 650 8 | | |
| | 32 | C146 11R024 600 8 | | |
| | 40 | C146 11R024 601 8 | | |
| Hood side entry low profile | 25 | C146 11R024 550 1 | | |
| | 32 | C146 11R024 500 1 | | |
| Hood side entry high profile | 25 | C146 11R024 550 8 | | |
| | 32 | C146 11R024 500 8 | | |
| | 40 | C146 11R024 501 8 | | |
| Housings | | | | |
| Housing bulkhead mounting Version A Standard flange without ground strap | | C146 11F024 901 8 | | |
| Housing bulkhead mounting Version B Standard flange with ground strap | | C146 11F024 902 8 | | |
| Housing bulkhead mounting Version C Centering flange with ground strap | | C146 11F024 000 8 | | |

Panel cut out



Version A + B



Version C

heavy|mate® Housings corrosion resistant Characteristics + Notes

| General Characteristics | Standard | Value |
|----------------------------|---------------------|----------------------------|
| Protection class housing | | IP 65 |
| Locking system | | 2 locking levers |
| Salt mist resistance | IEC 60512-11-6:2002 | >500h |
| Climatical Characteristics | | |
| Climatic category | IEC 60068-1 | 40 / 125 / 21 |
| Temperature range | IEC 60068-1 | - 40 °C / + 125 °C |
| Upper temperature | IEC 60512-11-9 | + 125 °C |
| Lower temperature | IEC 60512-11-10 | - 40 °C |
| Mechanical Characteristics | | |
| Mechanical operation | IEC 60512-9-1 | ≥ 500 mating cycles |
| Materials | | |
| Housings | | Aluminium die cast alloy |
| Colour housings | | grey, RAL 9005 |
| Rubber gasket | | NBR |
| Locking lever | | steel / special coated |
| Surface | | conducting special surface |

Wichtige Hinweise

500h salt mist resistance can be achieved when using a plastic cable gland.

When a metal cable gland is required, we recommend to use additionally our special studs on the hoods to achieve this value.

Order codes are:

[N16 025 0112 5X](#) Metal stud M25 corrosion resistant

[N16 032 0112 5X](#) Metal stud M32 corrosion resistant

[N16 040 0112 5X](#) Metal stud M40 corrosion resistant





heavy|mate® Housings corrosion resistant Size E10

| Description | M | Part Number | Drawing | Figure |
|---------------------------|----|-------------------|---------|--------|
| Hoods | | | | |
| Hood top entry | 25 | C146 50R010 600 1 | | |
| Hood side entry | 25 | C146 50R010 500 1 | | |
| Housings | | | | |
| Housing bulkhead mounting | | C146 50F010 000 1 | | |
| Panel cut out | | | | |
| | | | | |

heavy|mate® Housings corrosion resistant Size E16

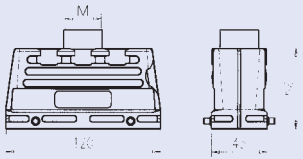
| Description | M | Part Number | Drawing | Figure |
|---------------------------|----|-------------------|---------|--------|
| Hoods | | | | |
| Hood top entry | 32 | C146 50R016 600 8 | | |
| Hood side entry | 32 | C146 50R016 500 8 | | |
| Housings | | | | |
| Housing bulkhead mounting | | C146 50F016 000 1 | | |
| Panel cut out | | | | |
| | | | | |

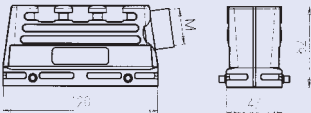
heavy|mate® Housings corrosion resistant Size E24

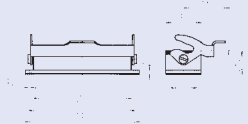
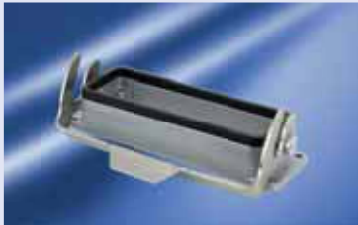
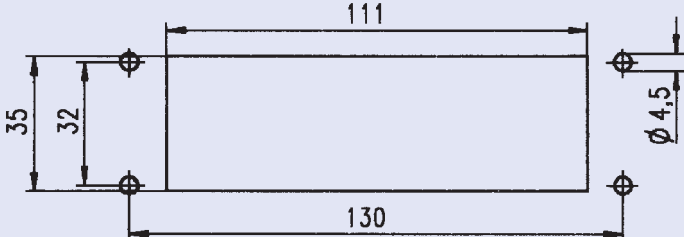
| Description | M | Part Number | Drawing | Figure |
|--|----|-------------------|---|--|
| Hoods | | | | |
| Hood top entry | 40 | C146 50R024 601 8 |  |  |
| Hood side entry | 40 | C146 50R024 501 8 |  |  |
| Housings | | | | |
| Housing bulkhead mounting | | C146 50F024 000 1 |  |  |
| Panel cut out | | | | |
|  | | | | |

heavy | mate[®] Accessories



- gland bushings
- EMC gland bushings
- Cable seals with cable clamp
- Key pin
- Guide pin / bush
- D-Sub adaptors
- Foam rubber sealing
- Label for CSA regulation

Assembly instructions for metric clamp

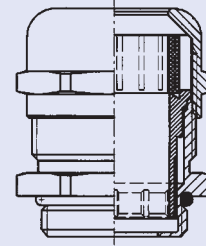
- The cable jacket should be removed as far as the underside of the cable clamping; the wire netting is then to be cut down a little further and subsequently must be formed into a circular rim. The protective jacket can remain attached to the cable provided that it passes through the lower opening of the clamp.
- On assembly, while screwing the cable clamp, the circular rim has to be pushed through and pressed on the fins commutator on the base of the underside and settle into a depression. By doing this the EMC security will remain.

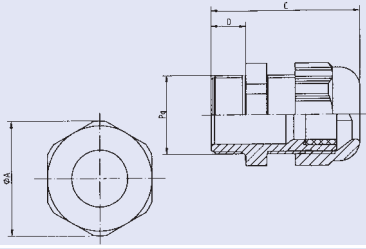

| Description | M | Part Number | Drawing | Figure |
|---|----|-----------------|---------|--------|
| Gland bushing IP 65¹⁾ | | | | |
| Thermoplast clamp with variable inner diameter 10 Pieces | 20 | VN16 200 0114 X | | |
| Metal with variable inner diameter 10 Pieces | 20 | VN16 200 0114 X | | |
| | 25 | VN16 250 0114 X | | |
| | 32 | VN16 320 0114 X | | |
| | 40 | VN16 400 0114 X | | |
| | 50 | VN16 500 0114 X | | |
| Cable clamp without gasket 5 Pieces | 16 | VN16 160 0102 V | | |
| | 20 | VN16 200 0102 V | | |
| | 25 | VN16 250 0102 V | | |
| | 32 | VN16 320 0102 V | | |
| Cable clamp without gasket 5 Pieces | 20 | VN16 200 0103 V | | |
| | 25 | VN16 250 0103 V | | |
| | 32 | VN16 320 0103 V | | |

| Description | Clamping range ø in mm | A in mm | M | Part Number | Drawing | Figure |
|---|---------------------------|---------|----|---------------------|--|---|
| Gland bushing IP 67 (Material PA / - 20 °C + 80 °C) | | | | | | |
| Gland bushing with vibration protection 10 Pieces | 4 - 10 | 20 | 16 | VN16 160 0127 X |  |  |
| | 6 - 12 | 24 | 20 | VN16 200 0127 X | | |
| | 9 - 16 | 28 | 25 | VN16 250 0127 X | | |
| | 10 - 21 | 36 | 32 | VN16 320 0127 X | | |
| | 16 - 28 | 46 | 40 | VN16 400 0127 X | | |
| Plugs brass nickel-plated with recess and o-ring 10 Pieces | | | 20 | VN16 020 0113 (1) X | |  |
| | | | 25 | VN16 025 0113 (1) X | | |
| | | | 32 | VN16 032 0113 (1) X | | |
| | | | 40 | VN16 040 0113 (1) X | | |

| Description | Clamping range F in mm | M | Part Number | Drawing | Figure |
|--|------------------------|----|-----------------|---------|---|
| EMV gland bushing IP 68 (Material CuZn / PA / - 30 °C + 120 °C) | | | | | |
| Gland bushing EMV 10 Pieces | 5.5 - 10 | 16 | VN16 160 0126 X | |  |
| | 8 - 13 | 20 | VN16 200 0126 X | | |
| | 11 - 18 | 25 | VN16 250 0126 X | | |
| | 15 - 21 | 32 | VN16 320 0126 X | | |
| | 19 - 27 | 40 | VN16 400 0126 X | | |

| Description | L | Part Number | Drawing | Figure |
|---|----|---------------------|---------|--------|
| Key pin with lock washer 10 Pieces | | VN17 050 0004 (1) | | |
| Key pin with lock washer 100 Pieces | | VN17 050 0004 (101) | | |
| Guide pin 10 Pieces | | VN13 040 0009 (1) X | | |
| Guide socket 10 Pieces | | VN13 040 0008 (1) X | | |
| Locking screw for contact inserts heavy mate ® D 15, D 25, A 10, A 16 20 Pieces | 23 | VN03 030 0021 | | |
| Locking screw for contact inserts heavy mate ® D 40, D 64, E, M, H 20 Pieces | 20 | VN03 030 0020 | | |
| Locking set 10 Pieces | | VN03 030 3000 X | | |

Polarization system with key pin

For housings with one contact insert

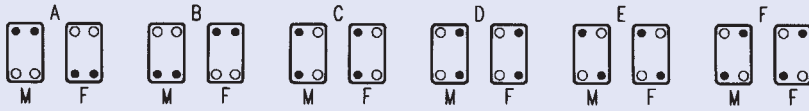

For housings with two contact inserts

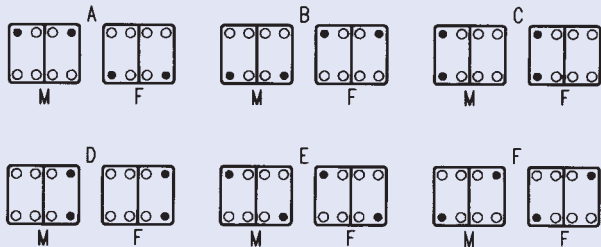

Descriptions

- Key pin
- Locking screw
- M Male insert
- F Female insert

Polarization system with guide pin and guide socket

For housings with one contact insert

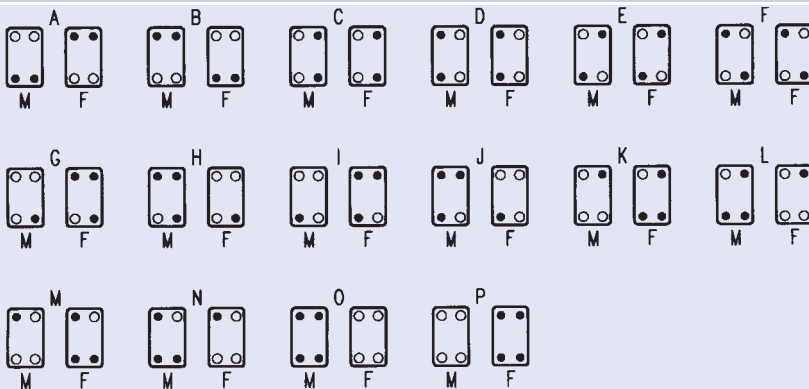



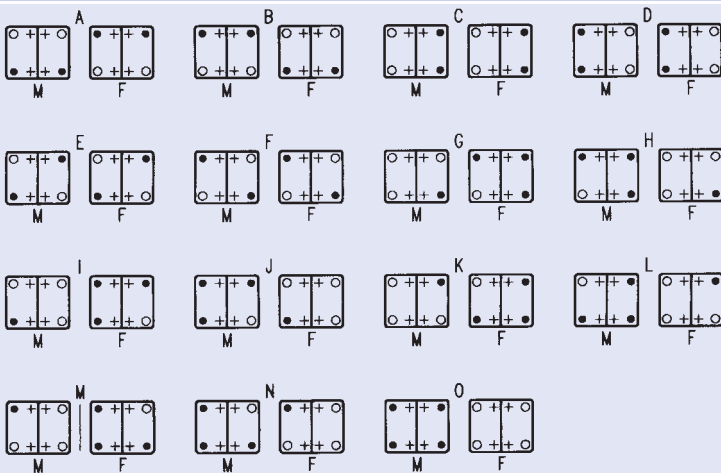



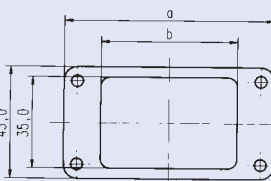

For housings with two contact inserts

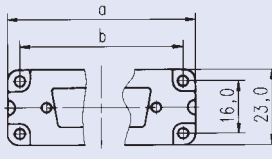

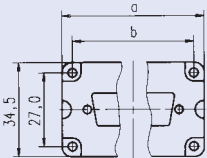

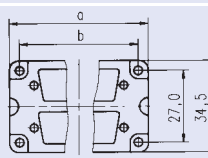







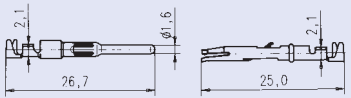
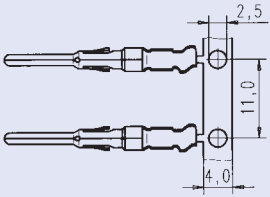

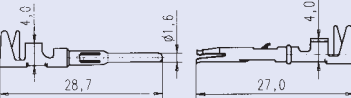
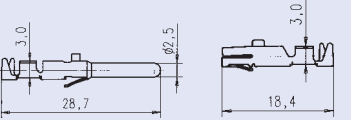

Descriptions

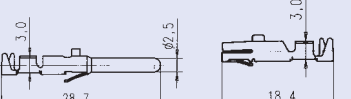
- Guide pin
- Guide socket
- + Locking screw
- M Male insert
- F Female insert

| Description | Size | Part Number | a | b | D-Sub | Drawing | Figure |
|----------------------------------|----------------|-----------------|------|------|-------|--|---|
| Foam rubber sealing 2 mm | 6 | N06 080 0003 1 | 80 | 70 | |  |  |
| | 10 | N06 080 0003 2 | 93 | 83 | | | |
| | 16 | N06 080 0003 3 | 113 | 103 | | | |
| | 24 | N06 080 0003 4 | 140 | 130 | | | |
| Adaptor for D-Sub set metal | 15 | C146 N32 015 G2 | 57 | 49,5 | 15 |  <p>2 x adaptor 4 x M3 x 6,5 8 x M3 x 14</p> |  |
| | 25 | C146 N32 025 G2 | 57 | 49,5 | 25 | | |
| Adaptor for D-Sub set single-row | 6 | C146 N32 009 G1 | 51,5 | 44 | 9 |  <p>2 x adaptor 4 x M3 x 6,5 8 x M3 x 14</p> |  |
| | 6 | C146 N32 015 G1 | 51,5 | 44 | 15 | | |
| | 10 | C146 N32 025 G1 | 64,5 | 57 | 25 | | |
| | 16 | C146 N32 037 G1 | 85 | 77,5 | 37 | | |
| | 16 | C146 N32 050 G1 | 85 | 77,5 | 50 | | |
| Adaptor for D-Sub set double-row | 6 | C146 N33 009 G1 | 51,5 | 44 | 9 |  <p>2 x adaptor 4 x M3 x 6,5 8 x M3 x 14</p> |  |
| | 6 | C146 N33 015 G1 | 51,5 | 44 | 15 | | |
| | 10 | C146 N33 025 G1 | 64,5 | 57 | 25 | | |
| | 16 | C146 N33 037 G1 | 85 | 77,5 | 37 | | |
| | 16 | C146 N33 050 G1 | 85 | 77,5 | 50 | | |
| Label for CSA application | N07 045 0001 L | | | | |  | |



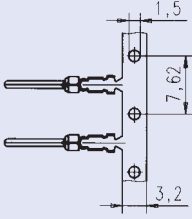

heavy | mate[®] Information

- Drawings contacts
- Safety classification
- Technical information

| Series | Drawing single contact | Drawing contacts on reel | Figure | |
|------------------|---|--|---|---|
| heavy mate® D, M | .N01 016 0003 1 .N02 016 0003 1  |  |  | |
| | .N01 016 0002 1 .N02 016 0002 1 .N01 016 0015 1 ¹⁾ .N02 016 0015 1 ¹⁾  | | |  |
| | .N01 016 0005 1 .N02 016 0005 1 .N01 016 0016 1 ¹⁾ .N02 016 0016 1 ¹⁾  | | | |
| heavy mate® E, M | .N01 025 0001 1 .N02 025 0001 1  |  |  | |
| | .N01 025 0010 1 .N02 025 0010 1  | | |  |
| | .N01 025 0043 1 .N02 025 0043 1  | | | |
| heavy mate® M | .N01 010 0130 2 .N02 010 0130 2  |  |  | |
| | .N01 010 0131 2 .N02 010 0131 2  | | |  |

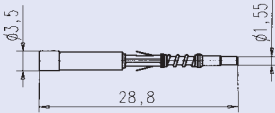
heavy|mate® Information Drawings turned contacts

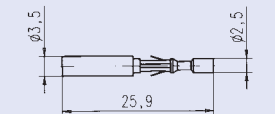
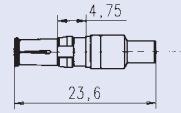
| Series | Part Number | Wire gauge | A | B | Drawing | Figure | |
|--|--------------------|-------------|------|------|-------------------|--------|--|
| heavy mate® D, DD, M 100 Pieces | VN01 016 0024 (1)C | 0,14 - 0,37 | 0,9 | 2,6 | .N01 016 002X | | |
| | VN01 016 0025 (1)C | 0,5 | 1,1 | 2,6 | | | |
| | VN01 016 0026 (1)C | 0,75 - 1,0 | 1,45 | 2,6 | | | |
| | VN01 016 0027 (1)C | 1,5 | 1,75 | 3,0 | | | |
| | VN01 016 0028 (1)C | 2,5 | 2,25 | 3,2 | | | |
| | VN02 016 0024 (1)C | 0,14 - 0,37 | 0,9 | 2,6 | .N02 016 002X | | |
| | VN02 016 0025 (1)C | 0,5 | 1,1 | 2,6 | | | |
| | VN02 016 0026 (1)C | 0,75 - 1,0 | 1,45 | 2,6 | | | |
| | VN02 016 0027 (1)C | 1,5 | 1,75 | 3,0 | | | |
| | VN02 016 0028 (1)C | 2,5 | 2,25 | 3,2 | | | |
| heavy mate® E, EE 100 Pieces | VN01 025 0035 (1)C | 0,5 | 1,1 | 2,6 | .N01 025 003X | | |
| | VN01 025 0036 (1)C | 0,75 - 1,0 | 1,45 | 2,6 | | | |
| | VN01 025 0037 (1)C | 1,5 | 1,75 | 3,0 | | | |
| | VN01 025 0038 (1)C | 2,5 | 2,3 | 3,2 | | | |
| | VN01 025 0039 (1)C | 4,0 | 2,9 | 4,0 | | | |
| | VN02 025 0035 (1)C | 0,5 | 1,1 | 2,6 | .N02 025 003X | | |
| | VN02 025 0036 (1)C | 0,75 - 1,0 | 1,45 | 2,6 | | | |
| | VN02 025 0037 (1)C | 1,5 | 1,75 | 3,0 | | | |
| | VN02 025 0038 (1)C | 2,5 | 2,3 | 3,2 | | | |
| | VN02 025 0039 (1)C | 4,0 | 2,9 | 4,0 | | | |
| heavy mate® M 100 Pieces | VN01 025 0029 (1)C | 0,5 | 1,1 | 2,6 | .N01 025 00XX | | |
| | VN01 025 0030 (1)C | 0,75 - 1,0 | 1,45 | 2,6 | | | |
| | VN01 025 0031 (1)C | 1,5 | 1,75 | 3,0 | | | |
| | VN01 025 0032 (1)C | 2,5 | 2,25 | 3,45 | | | |
| | VN01 025 0033 (1)C | 4,0 | 2,85 | 3,9 | | | |
| | VN02 025 0029 (1)C | 0,5 | 1,1 | 2,6 | .N02 025 00XX | | |
| | VN02 025 0030 (1)C | 0,75 - 1,0 | 1,45 | 2,6 | | | |
| | VN02 025 0031 (1)C | 1,5 | 1,75 | 3,0 | | | |
| | VN02 025 0032 (1)C | 2,5 | 2,25 | 3,45 | | | |
| | VN02 025 0033 (1)C | 4,0 | 2,85 | 3,9 | | | |
| | VN01 036 0004 (1)C | 1,5 | 1,75 | 3,0 | .N01 036 000X | | |
| | VN01 036 0005 (1)C | 2,5 | 2,25 | 3,45 | | | |
| | VN01 036 0001 (1)C | 4,0 | 2,85 | 3,9 | | | |
| | VN01 036 0002 (1)C | 6,0 | 3,55 | 4,9 | | | |
| | VN01 036 0003 (1)C | 10,0 | 4,4 | 5,9 | | | |
| | VN02 036 0004 (1)C | 1,5 | 1,75 | 3,0 | .N02 036 000X | | |
| VN02 036 0005 (1)C | 2,5 | 2,25 | 3,45 | | | | |
| VN02 036 0001 (1)C | 4,0 | 2,85 | 3,9 | | | | |
| VN02 036 0002 (1)C | 6,0 | 3,55 | 4,9 | | | | |
| VN02 036 0003 (1)C | 10,0 | 4,4 | 5,9 | | | | |

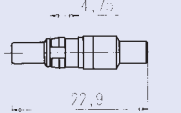
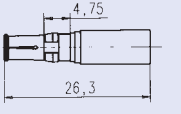
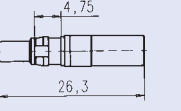
| Series | Part Number | Drawing single contact | Figure |
|---------------------|----------------|---|--|
| heavy mate® M, FO | N01 016 0040 8 |  |  |
| | N02 016 0040 8 |  | |
| heavy mate® M, Coax | 17 DM 537 421 |  |  |
| | 17 DM 537 401 |  | |
| | 17 DM 537 425 |  | |
| | 17 DM 537 405 |  | |

| Style | enclosed | unenclosed | earthing contact | cable clamp | finger safety mated |
|-------------------------------------|----------|------------|------------------|-------------|---------------------|
| Hood with pin insert | ● | | ● | | ● |
| Pin insert | | ● | ● | | |
| Hood with socket insert | ● | | ● | | ● |
| Socket insert | | ● | ● | | |
| Coupling housing with pin insert | ● | | ● | | ● |
| Coupling housing with socket insert | ● | | ● | | ● |
| Housing with pin insert | ● | | ● | | ● |
| Housing with socket insert | ● | | ● | | ● |

If not otherwise stated the contact inserts have to be mounted in metallic conductive housings resp. on bars or mounting boards to complete the protective earth grounding.

| finger safety unmated | hand back safety mated | connetor with breaking capacity ¹⁾ | rewirable | Cable clamp | | Style |
|--------------------------|---------------------------|--|-----------|--------------------|-----------------------|-------------------------------------|
| | | | | with ²⁾ | without ³⁾ | |
| | ● | ● | ● | ● | ● | Hood with pin insert |
| | | ● | ● | 4) | ● | Pin insert |
| ● | ● | ● | ● | ● | ● | Hood with socket insert |
| | | ● | ● | 4) | ● | Socket insert |
| | | ● | ● | ● | ● | Coupling housing with pin insert |
| ● | ● | ● | ● | ● | ● | Coupling housing with socket insert |
| | ● | ● | ● | ● | ● | Housing with pin insert |
| ● | ● | ● | ● | ● | ● | Housing with socket insert |



General technical information

- The Safty of connectors/connectors with braking capacity (CBC) depends on the right selection of products, the correct installation and a proper assembly.
- Decisions for the application of connectors are the requirements of the equipment specifications. This is especially the case for the definition of the rated voltage and the related clearances and creepage distances.
- All rated data for the connectors listed in this catalogue is based on overvoltage category III and pollution degree 3 (machine tool application).
- All technical data is specified for connectors, which are not under load when mated or disconnected. If in special cases connectors can be used in the sense of plug and socket devices (connector with breaking capacity), this is mentioned in the brief information of the particular section.
- Correct mounting will protect against electrical shock when mating the connectors.
- It connectors are mounted in non conductive housings both protective earthing terminals shall be mounted.
- A detailed connector glossary can be found at the end of this catalogue.
- All mentioned excerpts of standards are for general information only. For specific cases the valid original standards have to be consulted.
- Test methods acc. IEC 60512 camply with test methods acc. DIN EN 60512 or DIN IEC 60512. IEC 60664-1 complies with DIN VDE 0110-1

Termination methods: Screw connection

Screw clamps are designed acc. to EN 60999-1/VDE 0609. Chart 1 below shows the screw size depending on wire size and the required clamping and testing torque.

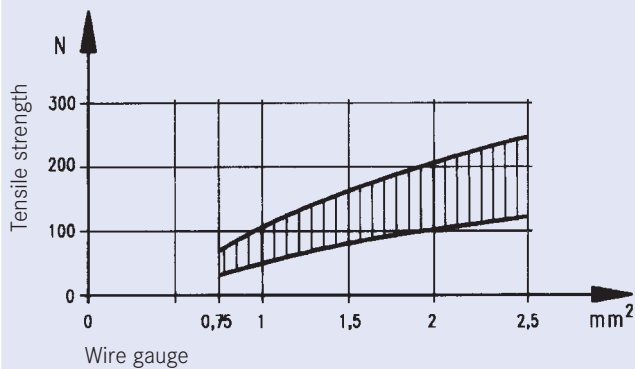

Chart 1

| | | | | | | |
|-----------------------------------|-------|-----|-----|-------|-----|-----|
| Wire size (mm²) | 1 | 1.5 | 2.5 | 4 | 6 | 10 |
| Screw size | M 2.6 | M 3 | M 3 | M 3.5 | M 4 | M 4 |
| Test torque (Ncm) | 40 | 50 | 50 | 80 | 120 | 120 |

Diagram 1 below shows the range of tensile strength for a screw connection with a clamp screw M3, fastened with a torque of 50 Ncm, depending on the wire size.

Diagram 1



Crimp connection **Chart 2: Tensile strength for crimp connetions**

A crimp connection is a non-detachable electrical connection between a wire and a crimp contact produced with the crimp technology. Precise crimping dies are matched to the crimp barrel and the wire size and a defined deformation results in a reliable electrical connection. There are open barrels (stamped contacts) and closed crimp barrels (turned contacts).

The main advantages of crimp connections are:

- Efficient termination of contacts.
- Reproduceable electrical and mechanical figures by a constant crimp quality.

(A detailed description of the crimp technology can be found in our catalogue "tools").

The requirements for crimp connections are defined in DIN EN 60352-2.

An important point for the quality of a crimp connection is the achieved tensile strength of the termination. Measuring the tensile strength is a practicable means for quality control purposes. Chart 2 below shows the required minimum tensile strength for open and closed barrels according to the wire size.

| Wire size | | Tensile strength |
|-----------------|-------------------|------------------|
| mm ² | AWG ¹⁾ | N |
| 0.05 | 30 | 6 |
| 0.08 | 28 | 11 |
| 0.12 | 26 | 15 |
| 0.14 | | 18 |
| 0.22 | 24 | 28 |
| 0.25 | | 32 |
| 0.32 | 22 | 40 |
| 0.5 | 20 | 60 |
| 0.75 | | 85 |
| 0.82 | 18 | 90 |
| 1.0 | | 108 |
| 1.3 | 16 | 135 |
| 1.5 | | 150 |
| 2.1 | 14 | 200 |
| 2.5 | | 230 |
| 3.3 | 12 | 275 |
| 4.0 | | 310 |
| 5.3 | 10 | 355 |
| 6.0 | | 360 |
| 8.4 | 8 | 370 |
| 10.0 | | 380 |

Cross reference AWG - mm²

The chart below allows a cross reference between American Wire Gauge (AWG) and metric wire sizes (mm²).

Chart 3

| AWG | Wire composition | Leiter-Ø | Wire size | AWG | Wire composition | Leiter-Ø | Wire size | |
|-----|------------------|----------|----------------------|-----|------------------|-----------|----------------------|----------------------|
| 30 | 1 x 0.25 | 0.25 mm | 0.05 mm ² | 20 | 1 x 0.81 | 0.81 mm | 0.52 mm ² | |
| | 7 x 0.10 | 0.36 mm | 0.06 mm ² | | 7 x 0.32 | 0.97 mm | 0.56 mm ² | |
| 28 | 1 x 0.32 | 0.32 mm | 0.08 mm ² | 18 | 19 x 0.20 | 1.02 mm | 0.62 mm ² | |
| | 7 x 0.13 | 0.38 mm | 0.09 mm ² | | 1 x 1.02 | 1.02 mm | 0.79 mm ² | |
| 26 | 1 x 0.40 | 0.40 mm | 0.13 mm ² | 16 | 19 x 0.25 | 1.27 mm | 0.96 mm ² | |
| | 7 x 0.16 | 0.48 mm | 0.14 mm ² | | 19 x 0.29 | 1.44 mm | 1.23 mm ² | |
| | 19 x 0.10 | 0.51 mm | 0.15 mm ² | | 14 | 19 x 0.36 | 1.80 mm | 1.95 mm ² |
| 24 | 1 x 0.51 | 0.51 mm | 0.21 mm ² | 12 | 19 x 0.46 | 2.29 mm | 3.09 mm ² | |
| | 7 x 0.20 | 0.61 mm | 0.23 mm ² | | 10 | 37 x 0.40 | 3.10 mm | 4.60 mm ² |
| | 19 x 0.13 | 0.64 mm | 0.24 mm ² | | | 8 | 133 x 0.29 | 4.0 mm |
| 22 | 1 x 0.64 | 0.64 mm | 0.33 mm ² | 6 | 133 x 0.36 | 5.5 mm | 13.5 mm ² | |
| | 7 x 0.25 | 0.76 mm | 0.36 mm ² | | | | | |
| | 19 x 0.16 | 0.81 mm | 0.38 mm ² | | | | | |

It has to be noted that wires of the same AWG number but with different composition have slightly different mm².

Chart 4: Composition and Dimensions of Copper Wires

| Wire Size | Wire Composition | Wire diameter |
|----------------------|------------------|---------------|
| 0.09 mm ² | 12 x 0.10 | 0.48 mm |
| 0.14 mm ² | 18 x 0.10 | 0.50 mm |
| 0.25 mm ² | 14 x 0.15 | 0.70 mm |
| 0.34 mm ² | 7 x 0.25 | 0.78 mm |
| 0.5 mm ² | 16 x 0.20 | 1.0 mm |
| 0.75 mm ² | 24 x 0.20 | 1.2 mm |
| 1.0 mm ² | 32 x 0.20 | 1.4 mm |
| 1.5 mm ² | 30 x 0.25 | 1.6 mm |
| 2.5 mm ² | 35 x 0.30 | 2.2 mm |
| 4.0 mm ² | 56 x 0.30 | 2.8 mm |
| 6.0 mm ² | 19 x 0.64 | 3.4 mm |
| 10 mm ² | 19 x 0.80 | 4.3 mm |

Current carrying capacity

The current carrying capacity of a connector is shown by a derating curve. The curve shows the currents that the connector can carry continuously and simultaneously through all its contacts. The curve is determined by testing following the standard DIN EN 60512. The upper temperature is limited by the contact and insulation material used. The sum of the ambient temperature and the temperature created by the current flow may not exceed the upper temperature. This means that the current carrying capacity has no fixed value but decreases with increasing ambient temperatures.

As a general example it can be said that a given connector which can carry 16A through all its contacts at 40°C ambient temperature can carry less, e.g. 12A, at an ambient temperature of 80°C. On the other hand it is often the case that not all contacts carry the whole rated current, which means that some single contacts may carry a higher current than that according to the derating curve. These currents have to be defined by testing.

Diagram 3: Typical derating curve

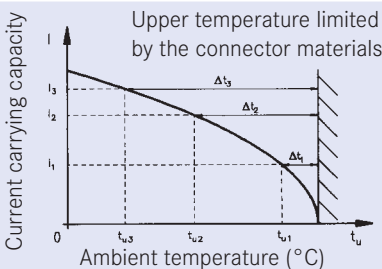
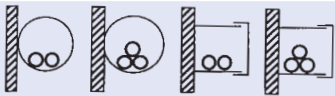
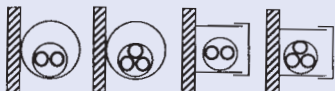



Chart 5: Current carrying capacity of copper wires in (A)

| Installation type | Wire size (mm ²) | 0.25 | 0.34 | 0.5 | 0.75 | 1 | 1.5 | 2.5 | 4 | 6 | 10 |
|--|------------------------------|------|------|-----|------|------|------|------|----|----|----|
|  B1 Wires in conduits and installation channels | | - | - | - | 7.6 | 10.4 | 13.5 | 18.3 | 25 | 32 | 44 |
|  B2 Cables and conductors in conduits or installation channels | | - | - | - | - | 9.6 | 12 | 16.5 | 23 | 29 | 40 |
|  C Cables and conductors along walls | | 4.0 | 5.0 | 7.1 | 9.1 | 11.7 | 15.2 | 21 | 28 | 36 | 50 |
|  E Cables and conductors on plank | | 4.0 | 5.0 | 7.1 | 9.1 | 11.5 | 16.1 | 22 | 30 | 37 | 52 |

Description according to DIN EN 60204 for PVC insulated copper wires with a working temperature of +40C. For other requirements,

such as for other temperatures, mountings, or wires corresponding correction factors are used (see next page).

Reduction values

The values in chart 5 are based on an ambient temperature of 40 °C. For other ambient temperatures the values have to be adjusted using the correction values of chart 6 below.

For installations with many cables and conductors under load the current carrying capacity is reduced according to the two following charts 7 and 8.

Chart 6

| Ambient temperature (°C) | Correction value |
|--------------------------|------------------|
| 30 | 1.15 |
| 35 | 1.03 |
| 40 | 1.00 |
| 45 | 0.91 |
| 50 | 0.82 |
| 55 | 0.71 |
| 60 | 0.58 |

Chart 7: Reduction values for accumulated conductors

| Installation type | Number of cables and conductors / pairs under load | | | |
|---|--|------|------|------|
| | 2 | 4 | 6 | 9 |
| Threephase cable and conductor | | | | |
| B1 and B2 | 0.80 | 0.85 | 0.87 | 0.86 |
| C | 0.65 | 0.75 | 0.78 | 0.76 |
| E-one row | 0.57 | 0.72 | 0.75 | 0.72 |
| E-multi row | 0.50 | 0.70 | 0.73 | 0.88 |
| DC conductor (pair), independent of installation type | 1.0 | 0.76 | 0.64 | 0.43 |

Chart 8: Reduction values for multicore cable and conductors up to 10mm²

| Number of conductors (pairs) under load | AC (conductor > 1 mm²) | DC (Pairs 0,2 to 0,75 mm²) |
|---|------------------------|----------------------------|
| 5 | 0.75 | 0.52 |
| 7 | 0.65 | 0.45 |
| 10 | 0.55 | 0.39 |
| 24 | 0.40 | 0.27 |

Conductors of control circuits generally do not need a reduction.

Impulse current carrying capacity

A surge can happen to a connector and its contacts by an impulse current, e.g. through a short circuit in the system or by switching operations. The short-timed high current heat cannot be transferred outside fast enough so the contacts are stressed by the high temperature which in the worst case can lead to a local weld.

The robust design of our connectors prevents most damage by impulse currents.

The diagram 4 below can be used as a guideline.

Chart 4: Impulse current carrying capacity of single contacts

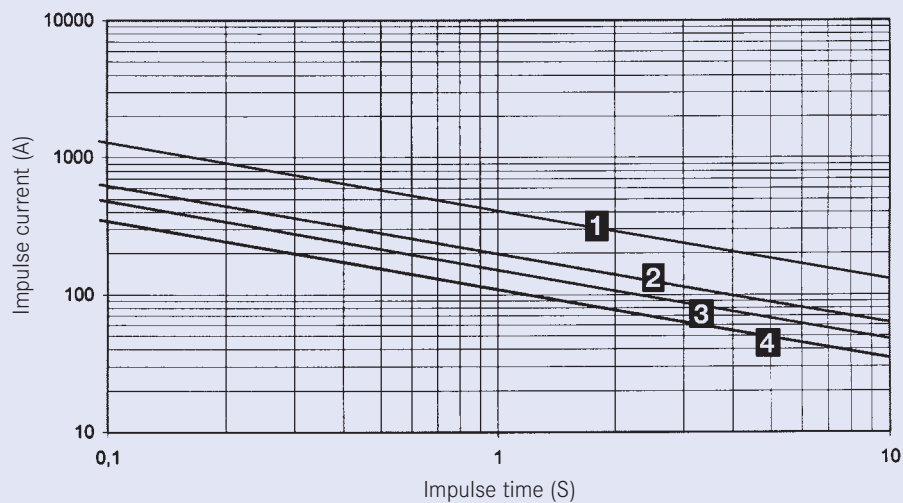

| Curve No. | Connector style | Curve No. | Connector style |
|-----------|--|-----------|--|
| 1 | heavy mate® E or A with screw contact | 3 | heavy mate® S with stamped crimp contact |
| 2 | heavy mate® E with stamped crimp contact | 4 | heavy mate® D with stamped crimp contact |

Voltage grading of connectors

General

Clearances and creepage distances are the base for voltage grading of connectors. Valuation and dimensioning of clearances and creepage distances have changed since the introduction of insulation coordination.

Insulation coordination comprises the selection of the electrical insulation performances of the equipment, taking into account the expected use and its environment.

The following standards apply for this:

IEC 60664-1/10.92
Insulation coordination for equipment within low-voltage systems

DIN VDE 0110-1/4.97
Isolationskoordination für elektrische Betriebsmittel in Niederspannungsanlagen

Clearances

The clearance is the shortest distance in air between two conductive parts. An important point for the dimensioning of clearances is the determination of the overvoltage category. The above standard specifies the possible overvoltages into the four following categories:

Overvoltage category I

Equipment intended for the use in appliances or parts of installations in which no overvoltage can occur. Examples are low-voltage equipments.

Overvoltage category II

Equipment intended for the use in installations or parts of it in which lightning overvoltages do not need to be considered, but switching overvoltages generated by the equipment do need to be considered. Examples are household appliances.

Overvoltage category III

Equipment intended for the use in installations or parts of it in which lightning overvoltages do not need to be considered, however switching overvoltages generated by the equipment, and for cases where the reliability and the availability of the equipment or its dependent circuits are subject to special requirements. Examples are protecting means, switches and sockets.

Overvoltage category IV

Equipment intended for the use in installations or parts of it in which lightning overvoltage has to be considered. Examples are electricity meters, overcurrent protection switches.

Once the overvoltage category has been defined the rated impulse withstand voltage can be selected for the equipment based on the nominal voltage of the supply system and the overvoltage category using chart 9 below:

Chart 9

| Nominal voltage of the supply system in V (based on IEC 60038) | Rated impulse voltage in kV for overvoltage category | | | |
|--|--|-----|-----|-----|
| | IV | III | II | I |
| Three phase systems | IV | III | II | I |
| 230/400 277/480 | 6 | 4 | 2,5 | 1,5 |
| 400/690 | 8 | 6 | 4 | 2,5 |
| 1000 | 12 | 8 | 6 | 4 |

After the rated impulse withstand voltage has been selected the pollution degree must be defined taking the expected pollution around the equipment into account.

The following four degrees of pollution are established:

Pollution degree 1

No pollution or only dry, non-conductive pollution occurs. The pollution has no influence.

Pollution degree 2

Only non-conductive pollution occurs except occasionally a temporary conductivity caused by condensation is to be expected.

Pollution degree 3

Conductive pollution occurs or dry non-conductive pollution occurs which becomes conductive due to condensation which is to be expected.

Pollution degree 4

The pollution generates persistent conductivity caused by conductive dust or by rain or snow.



It has to be noted that for a connector or plug and socket device with a degree of protection of min. IP 54 the parts inside the enclosure may be dimensioned for a lower pollution degree. This also applies to mated connectors which enclosure is ensured through the connector housing and which may only be disengaged for test and maintenance purposes.

When impulse withstand voltage and the pollution degree are defined the minimum clearances can be selected from chart 10.

Chart 10

| Impulse withstand voltage in kV | Minimum clearances in air in mm up to 2000 m above sea level | | | | | | | |
|---------------------------------|--|------|-----|-----|----------------------------|------|------|------|
| | Case A (non homogeneous field) | | | | Case B (homogeneous field) | | | |
| | Pollution degree | | | | Pollution degree | | | |
| | 1 | 2 | 3 | 4 | 1 | 2 | 3 | 4 |
| 0.33 | 0.01 | 0.2 | 0.8 | 1.6 | 0.01 | 0.2 | 0.8 | 1.6 |
| 0.40 | 0.02 | | | | 0.02 | | | |
| 0.50 | 0.04 | | | | 0.04 | | | |
| 0.60 | 0.06 | | | | 0.06 | | | |
| 0.80 | 0.10 | | | | 0.1 | | | |
| 1.0 | 0.15 | | | | 0.15 | | | |
| 1.2 | 0.25 | 0.25 | | | 0.2 | | | |
| 1.5 | 0.5 | | | | 0.3 | | | |
| 2.0 | 1.0 | 1.0 | 1.0 | | 0.45 | 0.45 | | |
| 2.5 | 1.5 | 1.5 | | | 0.6 | 0.6 | | |
| 3.0 | 2 | 2 | 2 | 2 | 0.8 | 0.8 | | |
| 4.0 | 3 | 3 | 3 | 3 | 1.2 | 1,2 | | |
| 5.0 | 4 | 4 | 4 | 4 | 1.5 | 1.5 | 1.5 | |
| 6.0 | 5.5 | 5.5 | 5.5 | 5.5 | 2 | 2 | 2 | |
| 8.0 | 8 | 8 | 8 | 8 | 3 | 3 | 3 | 3 |
| 10 | 11 | 11 | 11 | 11 | 3.5 | 3.5 | 3.5 | 3.5 |
| 12 | 14 | 14 | 14 | 14 | 4.5 | 4.5 | 4.5 | 4.5 |
| 15 | 18 | 18 | 18 | 18 | 5.5 | 5.5 | 5.5 | 5.5 |
| 20 | 25 | 25 | 25 | 25 | 8 | 8 | 8 | 8 |
| 25 | 33 | 33 | 33 | 33 | 10 | 10 | 10 | 10 |
| 30 | 40 | 40 | 40 | 40 | 12.5 | 12.5 | 12.5 | 12,5 |
| 40 | 60 | 60 | 60 | 60 | 17 | 17 | 17 | 17 |
| 50 | 75 | 75 | 75 | 75 | 22 | 22 | 22 | 22 |
| 60 | 90 | 90 | 90 | 90 | 27 | 27 | 27 | 27 |
| 80 | 130 | 130 | 130 | 130 | 35 | 35 | 35 | 35 |
| 100 | 170 | 170 | 170 | 170 | 45 | 45 | 45 | 45 |

When defining the minimum clearances for connectors generally the values of the inhomogeneous field can be chosen or the required clearance has to be defined by a voltage test.

Creepage distances

The creepage distance is the shortest distance along the surface of the insulating material between two conductive parts. For the dimensioning of the creepage distance the following factors are taken into account: the rated voltage, the pollution degree and the tracking formation of the insulating material.

The materials are separated into four groups according to their CTI values (Comparative Tracking Index):

- Material group I 600 ≤ CTI
- Material group II 400 ≤ CTI < 600
- Material group IIIa 175 ≤ CTI < 400
- Material group IIIb 100 ≤ CTI < 175

The minimum creepage distances can be selected from chart 11 .

Chart 11

| U-eff Rated vol- tage U in V | Min. creepage distance in mm | | | | | | | | | | | | | | | | | | |
|---------------------------------------|------------------------------|-------|-------|--------------------|------|------|----|--------------------|------|------|----|--------------------|------|------|----|--------------------|------|--|--|
| | Printed circuits | | | Other devices | | | | | | | | | | | | | | | |
| | Pollution degree | | | Pollution degree 1 | | | | Pollution degree 2 | | | | Pollution degree 3 | | | | Pollution degree 4 | | | |
| | 1 | | 2 | 1 | | 2 | | 3 | | 3 | | 4 | | 4 | | 4 | | | |
| | 2) | | 3) | 2) | | I | II | IIIa | IIIb | I | II | IIIa | IIIb | I | II | IIIa | IIIb | | |
| 10 | 0.025 | 0.04 | 0.08 | 0.4 | 0.4 | 0.4 | | 1 | 1 | 1 | | 1.6 | 1.6 | 1.6 | | | | | |
| 12.5 | 0.025 | 0.04 | 0.09 | 0.42 | 0.42 | 0.42 | | 1.05 | 1.05 | 1.05 | | 1.6 | 1.6 | 1.6 | | | | | |
| 16 | 0.025 | 0.04 | 0.1 | 0.45 | 0.45 | 0.45 | | 1.1 | 1.1 | 1,1 | | 1.6 | 1.6 | 1.6 | | | | | |
| 20 | 0,025 | 0.04 | 0.11 | 0.48 | 0.48 | 0.48 | | 1.2 | 1.2 | 1.2 | | 1.6 | 1.6 | 1,6 | | | | | |
| 25 | 0,025 | 0.04 | 0.125 | 0.5 | 0.5 | 0.5 | | 1.25 | 1.25 | 1.25 | | 1.7 | 1.7 | 1.7 | | | | | |
| 32 | 0.025 | 0.04 | 0.14 | 0.53 | 0.53 | 0.53 | | 1.3 | 1.3 | 1.3 | | 1.8 | 1.8 | 1.8 | | | | | |
| 40 | 0.025 | 0.04 | 0.16 | 0.56 | 0.8 | 1.1 | | 1.4 | 1.6 | 1.8 | | 1.9 | 2.4 | 3 | | | | | |
| 50 | 0.025 | 0.04 | 0.18 | 0.6 | 0.85 | 1.2 | | 1.5 | 1.7 | 1.9 | | 2 | 2.5 | 3.2 | | | | | |
| 63 | 0.04 | 0.063 | 0.2 | 0.63 | 0.9 | 1.25 | | 1,6 | 1.8 | 2 | | 2.1 | 2.6 | 3.4 | | | | | |
| 80 | 0.063 | 0.1 | 0.22 | 0.67 | 0.95 | 1.3 | | 1.7 | 1.9 | 2.1 | | 2.2 | 2.8 | 3.6 | | | | | |
| 100 | 0.1 | 0.16 | 0.25 | 0.71 | 1 | 1.4 | | 1.8 | 2 | 2.2 | | 2.4 | 3.0 | 3.8 | | | | | |
| 125 | 0.16 | 0.25 | 0.28 | 0.75 | 1.05 | 1.5 | | 1.9 | 2.1 | 2.4 | | 2.5 | 3.2 | 4 | | | | | |
| 160 | 0.25 | 0.4 | 0.32 | 0.8 | 1.1 | 1.6 | | 2 | 2.2 | 2.5 | | 3.2 | 4 | 5 | | | | | |
| 200 | 0.4 | 0.63 | 0.42 | 1 | 1.4 | 2 | | 2.5 | 2.8 | 3.2 | | 4 | 5 | 6.3 | | | | | |
| 250 | 0.56 | 1 | 0.56 | 1.25 | 1.8 | 2.5 | | 3.2 | 3.6 | 4 | | 5 | 6.3 | 8 | | | | | |
| 320 | 0.75 | 1.6 | 0.75 | 1.6 | 2.2 | 3.2 | | 4 | 4.5 | 5 | | 6.3 | 8 | 10 | | | | | |
| 400 | 1 | 2 | 1 | 2 | 2.8 | 4 | | 5 | 5.6 | 6.3 | | 8 | 10 | 12.5 | | | | | |
| 500 | 1.3 | 2.5 | 1.3 | 2.5 | 3.6 | 5 | | 6.3 | 7.1 | 8.0 | | 10 | 12.5 | 16 | | | | | |
| 630 | 1.8 | 3.2 | 1.8 | 3.2 | 4.5 | 6.3 | | 8 | 9 | 10 | | 12.5 | 16 | 20 | | | | | |
| 800 | 2.4 | 4 | 2.4 | 4 | 5.6 | 8 | | 10 | 11 | 12.5 | | 16 | 20 | 25 | | | | | |
| 1000 | 3.2 | 5 | 3.2 | 5 | 7.1 | 10 | | 12.5 | 14 | 16 | | 20 | 25 | 32 | | | | | |
| 1250 | | | 4.2 | 6.3 | 9 | 12.5 | | 16 | 18 | 20 | | 25 | 32 | 40 | | | | | |
| 1600 | | | 5.6 | 8 | 11 | 16 | | 20 | 22 | 25 | | 32 | 40 | 50 | | | | | |
| 2000 | | | 7.5 | 10 | 14 | 20 | | 25 | 28 | 32 | | 40 | 50 | 63 | | | | | |
| 2500 | | | 10 | 12.5 | 18 | 25 | | 32 | 36 | 40 | | 50 | 63 | 80 | | | | | |
| 3200 | | | 12.5 | 16 | 22 | 32 | | 40 | 45 | 50 | | 63 | 80 | 100 | | | | | |
| 4000 | | | 16 | 20 | 28 | 40 | | 50 | 56 | 63 | | 80 | 100 | 125 | | | | | |
| 5000 | | | 20 | 25 | 36 | 50 | | 63 | 71 | 80 | | 100 | 125 | 160 | | | | | |
| 6300 | | | 25 | 32 | 45 | 63 | | 80 | 90 | 100 | | 125 | 160 | 200 | | | | | |
| 8000 | | | 32 | 40 | 56 | 80 | | 100 | 110 | 125 | | 160 | 200 | 250 | | | | | |
| 10000 | | | 40 | 50 | 71 | 100 | | 125 | 140 | 160 | | 200 | 250 | 320 | | | | | |

Connectors in this catalogue are allocated to fixed rated voltages which apply to the machine building industry. In case of other applications the above chart can be used to determine other rated voltages.

Degree of protection

Electrical connector devices have to be protected for safety reasons from outside influences like dust, foreign objects, direct contact, moisture and water. This protection is provided on industrial connectors by the housing latching devices and sealed cable entries. The degree of protection depends on the type of intended use. The standard IEC 60529 and/or DIN EN 60529 has specified the degree of protection and divided them into several classes.

The degree of protection is indicated in the following way: IP 65
 Code letters (Internat. Protection) _____
 1st charact. numeral (degree of protection against access to hazardous parts and against solid foreign objects)
 2nd charact. numeral (degree of protection against ingress of water)
 The following charts 12 an13 give an overview about all protection degrees.

| Chart 12 | | | Chart 13 | | |
|----------------------|---|--|----------------------|---|--|
| 1st charact. numeral | Brief description | Definition | 2nd charact. numeral | Brief description | Definition |
| 0 | Non-protected | – | 0 | Non-protected | – |
| 1 | Protected against access to hazardous parts with the back of a hand. Protected against solid foreign objects of $\geq 50\text{mm } \varnothing$. | The probe, sphere of $50\text{mm } \varnothing$, shall not fully penetrate and shall have adequate clearance from hazardous parts. | 1 | Protected against vertically falling water drops | Vertically falling drops shall have no harmful effects. |
| 2 | Protected against access to hazardous parts with a finger. Protected against solid foreign objects of $\geq 12,5\text{mm } \varnothing$. | The jointed test finger of $12\text{mm } \varnothing$, 80mm length, shall have adequate clearance from hazardous parts. The probe, sphere of $12,5\text{mm } \varnothing$, shall not fully penetrate. | 2 | Protected against vertically falling water drops when enclosure tilted up to 15° | Vertically falling drops shall have no harmful effects when the enclosure is tilted at any angle up to 15° . |
| 3 | Protected against access to hazardous parts with a tool. Protected against solid foreign objects of $\geq 2,5\text{mm } \varnothing$. | The probe of $2,5\text{mm } \varnothing$ shall not penetrate at all. | 3 | Protected against spraying water | Water sprayed at any angle up to 60° shall have no harmful effects. |
| 4 | Protected against access to hazardous parts with a wire. Protected against solid foreign objects of $\geq 1\text{mm } \varnothing$. | The probe of $1\text{mm } \varnothing$ shall not penetrate at all. | 4 | Protected against splashing water | Water splashed against the enclosure from any direction shall have no harmful effects. |
| 5 | Protected against access to hazardous parts with a wire. Dust-protected. | The probe of $1\text{mm } \varnothing$ shall not penetrate. Intrusion of dust is not totally prevented, but dust shall not penetrate in a quantity to interfere with satisfactory operation of the device or to impair safety. | 5 | Protected against water jets | Water projected in jets against the enclosure from any direction shall have no harmful effects. |
| 6 | Protected against access to hazardous parts with a wire. Dust-tight. | The probe of $1\text{mm } \varnothing$ shall not penetrate. No intrusion of dust. | 6 | Protected against powerful water jets | Water projected in powerful jets against the enclosure from any direction shall have no harmful effects. |
| | | | 7 | Protected against the effects of temporary immersion in water | Intrusion of water in quantities causing harmful effects shall not be possible when the enclosure is temporarily immersed in water for 30 min. in 1m depth. |
| | | | 8 | Protected against the effects of continuous immersion in water | Intrusion of water in quantities causing harmful effects shall not be possible when the enclosure is continuously immersed in water under conditions which shall be agreed between manufacturer and user but which are more severe than for numeral 7. |
| | | | 9K ¹⁾ | Protected against water during high pressure/steam jet cleaning | Water projected in powerful jets with high pressure and heat against the enclosure from any direction shall have no harmful effects. |

Cable

For the termination of all Amphenol-industrial connectors we recommend the use of commercially available high flexible cable acc. to VDE or other local specifications. Our connectors are designed to fit these cables especially as far as number of conductors and cable diameters are concerned.

When selecting cables care must be taken that the cables do not affect (solvent) the connector or preserve an existing fire resistance.

Sealing

The sealing of the cable entries of all Amphenol-industrial connectors is with gland bushings. All sealings are made from Neoprene which has a good resistance against grease, oil and gasoline.

Selection of gland bushings

Beside glands with a fixed inside diameter which equals the number, there are also glands with variable inside diameters available (so-called onion glands). The inside diameter of these glands can be adjusted to the outside cable diameter by cutting out the smaller rings.

The selection of the appropriate gland bushing depends on the cable diameter (cable composition) can be made using the following diagram 5 (see page XXX).

Diagram 5

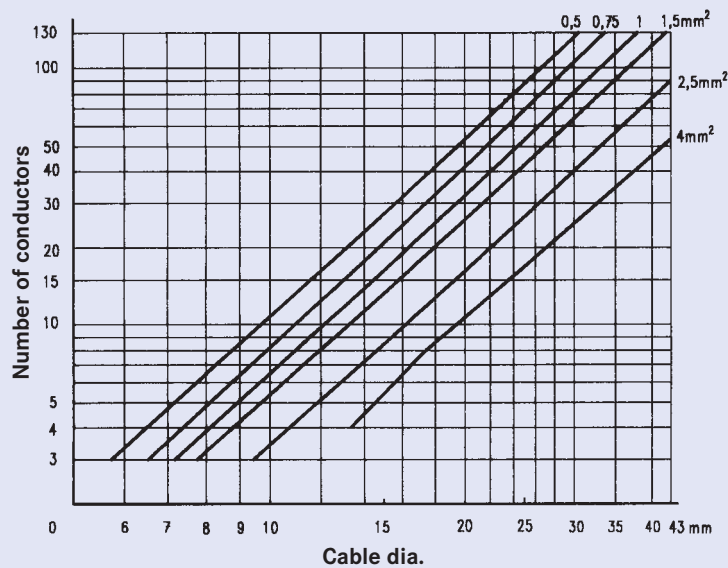

| | |
|---|--|
| <p>American Wire Gauge (AWG)</p> <p>System of numerical designations for wire sizes, based on specified ranges of cross-sectional areas.</p> <p>Starts with 4/0 (000) at the largest size, going to 3/0, 2/0, 1/0, 1, 2, and up to 40 and beyond for the smallest size. A step of one AWG number corresponds to a reduction of cross-sectional area of appr. 20 %.</p> | <p>Contact</p> <p>The conductive element in a connector which mates with a corresponding element to provide an electrical path.</p> |
| <p>Attenuation</p> <p>A reduction of power. Occurs naturally when waves travel through lines, wave guides, or media such as air or water. Is produced additionally by imperfections in electrical or optical connections (attenuation in fibre optics), e. g. contact resistance, mismatch, etc.</p> | <p>Contact resistance</p> <p>The electrical resistance of a mated set of contacts under specified conditions. Tested according to tests 2a, 2b, 2c, of IEC 60 512 -2/ DIN EN 60 512-2.</p> |
| <p>Bulkhead connector</p> <p>Connector designed to be inserted into a panel cutout from the rear of the panel, thus forming part of the barrier between two spaces. Back-mounted.</p> | <p>Contact size</p> <p>The designation used to differentiate one contact from another. It may be denoted by one of the following numbering systems:</p> <ul style="list-style-type: none"> • numbering system: assigned numbers used to denote the size of the contact and its related conductor accommodation (e. g. in AWG units), • current rating system: the related current-carrying capacity is used to denote the size of the contact, • cross-sectional area system: reference is made to the cross-sectional area of the maximum conductor accommodation to denote the size of the contact, e. g. in mm². |
| <p>Clearance</p> <p>The shortest distance in air between two conductive parts, see IEC 60664.</p> | <p>Creepage distance</p> <p>The shortest distance along the surface of the insulating material between two conductive parts. The longer the distance, the less the risk of arc damage or tracking. Minimum creepage distances are specified according to the rated voltage and the applicable pollution degree and Comparative Tracking Index.</p> |
| <p>Climatic stability</p> <p>General term describing the behavior of components under various climatic conditions, e. g. high and low temperatures, tropical climate, high humidity, moist heat, fungus, atmospheric conditions (industrial atmosphere), reduced air pressure, etc. Climatic conditions for test purposes are explained in IEC 60068, DIN 46 040.</p> | <p>Crimped connection</p> <p>A solderless connection made by crimping. IEC 60352-2 / DIN IEC 60352 Part 2.</p> |
| <p>Connector</p> <p>A component which terminates conductors for the purpose of providing connection and disconnection to a suitable mating component which shall not be engaged or disengaged when live. Depending on the fastening to a cabinet, panel, rack etc. or a cable, they are classified as fixed or free connectors. A connector comprises one or more contacts and a housing which may have a separate connector insert and a separate outer housing or shell.</p> | <p>Derating curve</p> <p>The method for determining derating is specified in IEC 60 512-3. Here the combination of ambient temperature (Tu) and the current (I) leading to the same maximum allowable temperature (Tb) at the hottest point of the connector are plotted.</p> |
| <p>Connector housing</p> <p>The part of a connector into which the insert and the contacts are assembled. It may function as part of the locking mechanism.</p> | <p>DIN</p> <p>Deutsches Institut für Normung. A German standards organization.</p> |
| <p>Connector insert</p> <p>An insulating element designed to support and position contacts in a connector housing.</p> | <p>Electromagnetic interference (EMI)</p> <p>General term describing the undesirable effects of the immission or emission of radio frequency fields.</p> <p>In connectors electromagnetic interference is prevented by shielding. Shielded connectors normally provide means to connect the screens of attached cables.</p> |
| <p>Connector life</p> <p>The number of mating cycles prior to abrasion of the conductive contact surface and which does not result in a significant rise of the contact resistance. Tests according to test 9a of ICE 60512-5 / DIN EN 60512 Part 5.</p> | <p>Funnel entry (restricted entry C146 D series)</p> <p>Flared or widened entrance to a conductor barrel permitting easier insertion of the conductor.</p> |

| | |
|---|---|
| <p>Insertion or withdrawal force</p> <p>The force required to fully insert or withdraw a set of mated connectors without the effect of coupling, locking or similar devices. The insertion force is usually greater than the withdrawal force.</p> | <p>Material group</p> <p>Classification of insulation materials according to their CTI values (CTI = Comparative Tracking Index)</p> |
| <p>Insulation grip</p> <p>The area of a crimp contact that has been reshaped around the insulation of the conductor by compression during the crimping operation.</p> | <p>Overvoltage category</p> <p>A numeral defining a transient overvoltage condition. Overvoltage categories I, II, III and IV are used.</p> |
| <p>Insulation resistance</p> <p>The resistance of the insulation between two conductive elements, in particular, the resistance between two contacts or between a contact and a metallic housing or shield. Tested according to test 3a of IEC 60512-2 / DIN IEC 60512 Part 2.</p> | <p>Connector with braking capacity (CBC)</p> <p>A component which may be engaged or disengaged in normal use, when live or under load. Note: In the sense of this document the term - live- is used if contacts are under voltage not necessarily with a current flowing across the contacts. The term - load - is used if a current is flowing across the contacts.</p> |
| <p>Intermateable</p> <p>Two connectors are intermateable when they are capable of being connected electrically and mechanically but without regard to their performance and intermountability.</p> | <p>Rated current</p> <p>A current value assigned by the manufacturer which the connector or PSD can carry continuously (without interruption) and simultaneously through all its contacts wired with the largest conductor preferably at an ambient temperature of 40 °C without the upper temperature being exceeded.</p> |
| <p>Locator</p> <p>In a crimping tool the device used for positioning a crimp contact or terminal end.</p> | <p>Shield, shielding</p> <p>Shielding of internal or external electric fields by means of a plane with a uniform electric potential, formed by metal shells or metallic layers on the inside or outside of plastic shells. The shield is normally connected to the shielding braid of the cable and/or chassis ground.</p> |
| <p>Locking lever</p> <p>A mechanical locking device operated by actuating a lever, designed to hold two mated connectors together. Typically the lever can only be fully locked if the two connectors are correctly mated.</p> | <p>Terminal block</p> <p>An assembly of terminals in a housing or body of insulating material to facilitate interconnection between multiple conductors. Also called terminal strip or barrier blocks if the terminals are separated by an insulation barrier.</p> |
| <p>Mating cycle</p> <p>One mating cycle comprises one insertion and one withdrawal operation. Term used in the definition of connector life.</p> | <p>Wire range</p> <p>The range of wire cross sections which is compatible with the dimensions the terminals of the contact (wire barrel). The wire range is expressed in mm² or in AWG numbers.</p> |

| Stamped crimp contacts series C146, stripping length | | | | | | |
|--|-----------------|---------|--------------------------------------|----------------------------|--|------------------------------------|
| Termination crimp [mm ²] | Wire gauge | | Insulation diameter of the wire [mm] | Min. stripping length [mm] | Contact Part Number | Series |
| | mm ² | AWG | | | | |
| 0.09 - 0.25 | 0.09 - 0.25 | 28 - 24 | 0.7 - 1.6 | 2.3 + 0.4 | N01 010 0130 (2) N02 010 0130 (2) | heavy mate® M heavy mate® M |
| 0.14 - 0.5 | 0.14 | 26 | 1.0 - 2.0 | 3.0 + 0.5 | N01 016 0003 N02 016 0003 | heavy mate® D/M |
| | 0.25 | 24-22 | | | | heavy mate® D/M |
| | 0.5 | 20 | | | | |
| 0.25 - 0.5 | 0.25 | 24-22 | 1.6 - 2.0 | 2.3 + 0.4 | N01 010 0131 (2) N02 010 0131 (2) | heavy mate® M |
| | 0.5 | 20 | | | | heavy mate® M |
| 0.5 - 1.5 | 0.5 | 20 | 1.8 - 2.8 | 3.5 + 1.0 | N01 016 0002 N02 016 0002 N01 016 0015 N02 016 0015 N01 025 0001 N02 025 0001 N01 025 0007 | heavy mate® D/M |
| | 0.75 | 20 - 18 | | | | heavy mate® D/M |
| | 1.0 | 18 - 16 | | | | heavy mate® D |
| | 1.5 | 16 - 15 | | | | heavy mate® D |
| | | | | | | heavy mate® E/M |
| 1.5 - 2.5 | 1.5 | 16 - 15 | 2.5 - 3.5 | 3.5 + 1.0 | N01 016 0005 N02 016 0005 N01 016 0016 N02 016 0016 N01 025 0010 N02 025 0010 N01 025 0008 | heavy mate® D/M |
| | 2.5 | 14 | | | | heavy mate® D/M |
| | | | | | | heavy mate® D |
| | | | | | | heavy mate® D |
| | | | | | | heavy mate® E/M |
| | | | | | | heavy mate® E/M/S |
| | | | | | | heavy mate® S |
| 2.5 - 4.0 | 2.5 | 14 | 3.3 - 4.2 | 3.5 + 1.0 | N01 025 0043 N02 025 0043 | heavy mate® M |
| | 4.0 | 12 | | | | heavy mate® M |

heavy | mate® Information Stripping length

| Turned crimp contacts series heavy mate®, stripping length | | | | | | |
|--|---------------------------------------|------------------------------|-------------------------|---------------------------------------|------------------------------|-----------------|
| Termination crimp [mm2] | Min. stripping length + Tolerance[mm] | Contact Part Number | Series | Min. stripping length + Tolerance[mm] | Contact Part Number | Series |
| | | | | | | |
| 0.14 - 0.37 | 8 + 1 | N01 016 0024 N02 016 0024 | heavy mate® D/DD/M | | | heavy mate® M |
| 0.5 | 8 + 1 | N01 016 0025 N02 016 0025 | heavy mate® D/DD/M | 7 + 1 | N01 025 0029 N02 025 0029 | heavy mate® M |
| 0.75 - 1.0 | 8 + 1 | N01 016 0026 N02 016 0026 | heavy mate® D/DD/M | 7 + 1 | N01 025 0030 N02 025 0030 | heavy mate® M |
| 1.5 | 8 + 1 | N01 016 0027 N02 016 0027 | heavy mate® D/DD/M | 7 + 1 | N01 025 0031 N02 025 0031 | heavy mate® M |
| 2.5 | 6 + 1 | N01 016 0028 N02 016 0028 | heavy mate® D/DD/M | 7 + 1 | N01 025 0032 N02 025 0032 | heavy mate® M |
| 4.0 | | | | 7 + 1 | N01 025 0033 N02 025 0033 | heavy mate® M |
| | | 2,5 (Contact without clip) | | 3,6 (Contact with clip) | | |
| 0.5 | 7 + 1 | N01 025 0035 N02 025 0035 | heavy mate® E/EE | | | |
| 0.75 - 1.0 | 7 + 1 | N01 025 0036 N02 025 0036 | heavy mate® E/EE | | | |
| 1.5 | 7 + 1 | N01 025 0037 N02 025 0037 | heavy mate® E/EE | 10 + 1 | N01 036 0004 N02 036 0004 | heavy mate® M |
| 2.5 | 7 + 1 | N01 025 0038 N02 025 0038 | heavy mate® E/EE | 10 + 1 | N01 036 0005 N02 036 0005 | heavy mate® M |
| 4.0 | 7 + 1 | N01 025 0039 N02 025 0039 | heavy mate® E/EE | 10 + 1 | N01 036 0001 N02 036 0001 | heavy mate® M |
| 6.0 | | | | 10 + 1 | N01 036 0002 N02 036 0002 | heavy mate® M |
| 10.0 | | | | 10 + 1 | N01 036 0003 N02 036 0003 | heavy mate® M |

Time saving through the introduction of stamped contacts

Wiring costs of different contacts

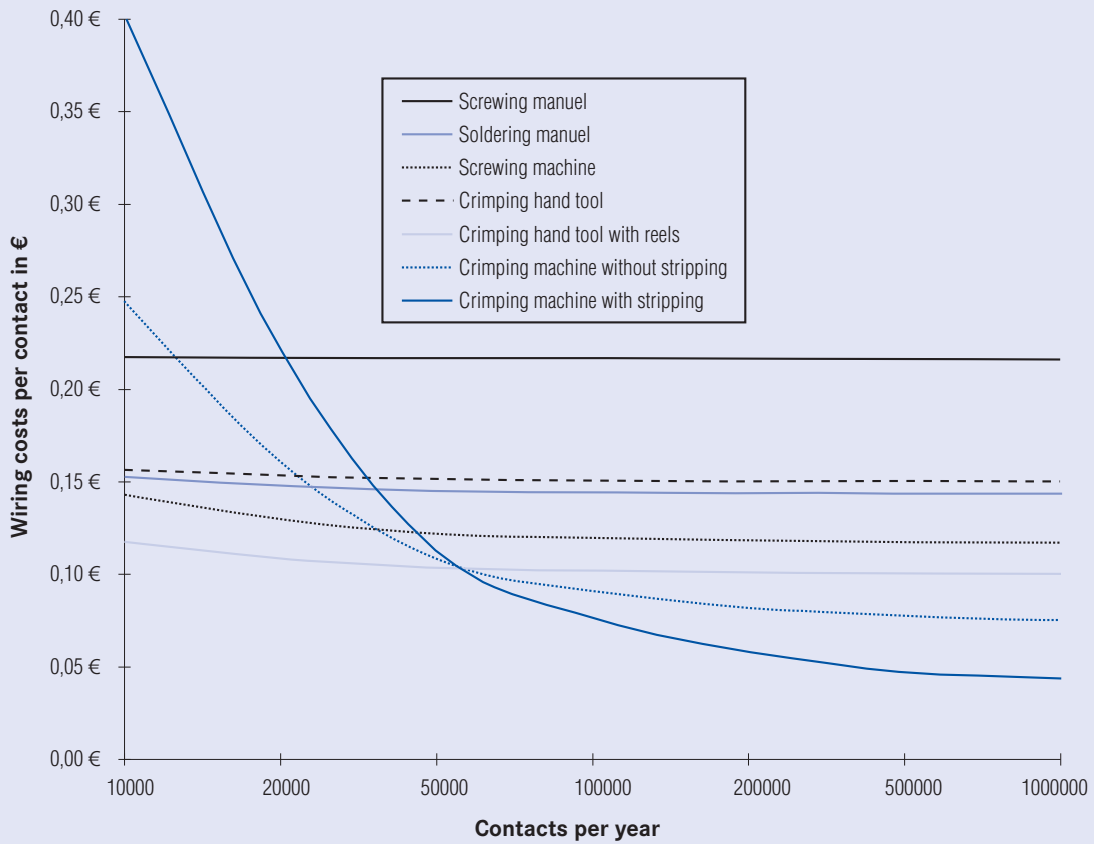

Break Even at about 60.000 contacts per year

| | |
|-------------------------|---------|
| General conditions | |
| Maturity (Depreciation) | 5 years |
| Interest | 8 % |
| Maintenance | 5 % |
| Hourly wages | 20 € |

Non binding declarations are based on experienced values.

heavy|mate[®] Summary of Part Numbers

| Part Number | Page | Part Number | Page | Part Number | Page | Part Number | Page |
|--------------------|---------------|--------------------|--------|--------------------|----------|-------------------|------|
| 17D 438 SP | 145, 154 | C146 10A024 400 1 | 54 | C146 10B016 002 3 | 105 | C146 10F024 003 1 | 190 |
| 17 DM 537 401 | 146, 147, 234 | C146 10A024 500 1 | 55, 56 | C146 10B016 002 4 | 20, 21 | C146 10F025 000 2 | 170 |
| 17 DM 537 405 | 146, 147, 234 | C146 10A024 505 1 | 56 | C146 10B016 004 4 | 21 | C146 10F025 003 2 | 170 |
| 17 DM 537 421 | 146, 147, 234 | C146 10A024 810 1 | 73 | C146 10B016 102 1 | 52 | C146 10F032 000 4 | 173 |
| 17 DM 537 425 | 146, 147, 234 | C146 10A025 000 2 | 29, 31 | C146 10B016 102 3 | 105, 106 | C146 10F048 001 1 | 196 |
| C146 10A003 002 4 | 18 | C146 10A025 005 2 | 31 | C146 10B016 102 4 | 20, 21 | C146 10F048 003 1 | 196 |
| C146 10A003 102 3 | 102 | C146 10A025 060 2 | 29 | C146 10B016 104 3 | 106 | C146 10N003 500 4 | 166 |
| C146 10A003 500 15 | 78, 83 | C146 10A025 500 2 | 29, 31 | C146 10B016 104 4 | 21 | C146 10N006 602 2 | 175 |
| C146 10A004 002 4 | 18 | C146 10A025 505 2 | 31 | C146 10B016 400 1 | 52 | C146 10N006 603 1 | 175 |
| C146 10A004 100 13 | 111 | C146 10A032 500 10 | 66 | C146 10B016 500 1 | 53 | C146 10N006 603 2 | 175 |
| C146 10A005 500 12 | 159 | C146 10A040 000 2 | 30 | C146 10B016 810 1 | 73 | C146 10N006 606 2 | 175 |
| C146 10A006 000 1 | 48 | C146 10A040 060 2 | 30 | C146 10B017 500 15 | 79, 91 | C146 10N006 607 1 | 175 |
| C146 10A006 002 1 | 48 | C146 10A040 500 2 | 30 | C146 10B018 500 10 | 65 | C146 10N006 607 2 | 175 |
| C146 10A006 100 13 | 111 | C146 10A042 000 9 | 41 | C146 10B020 500 15 | 79, 93 | C146 10N006 802 2 | 175 |
| C146 10A006 102 1 | 48 | C146 10A042 500 13 | 113 | C146 10B024 000 1 | 54, 56 | C146 10N006 803 1 | 175 |
| C146 10A006 102 3 | 103 | C146 10A046 500 10 | 66 | C146 10B024 000 9 | 41 | C146 10N006 806 1 | 175 |
| C146 10A006 102 5 | 97 | C146 10A064 000 2 | 32, 33 | C146 10B024 002 1 | 54, 56 | C146 10N006 806 2 | 175 |
| C146 10A006 400 1 | 48 | C146 10A064 005 2 | 33 | C146 10B024 005 1 | 56 | C146 10N006 807 1 | 175 |
| C146 10A006 500 1 | 49 | C146 10A064 060 2 | 32 | C146 10B024 102 1 | 54, 56 | C146 10N006 807 2 | 175 |
| C146 10A006 500 15 | 78, 85 | C146 10A064 500 2 | 32, 33 | C146 10B024 400 1 | 54 | C146 10N010 500 1 | 177 |
| C146 10A006 810 1 | 72 | C146 10A064 505 2 | 33 | C146 10B024 500 1 | 55, 56 | C146 10N010 500 2 | 177 |
| C146 10A007 000 2 | 27 | C146 10A072 000 9 | 41 | C146 10B024 505 1 | 56 | C146 10N010 501 1 | 177 |
| C146 10A007 500 2 | 27 | C146 10A108 000 9 | 42 | C146 10B024 810 1 | 73 | C146 10N010 501 2 | 177 |
| C146 10A007 500 12 | 161 | C146 10A108 005 9 | 42 | C146 10B025 000 2 | 29, 31 | C146 10N010 508 2 | 181 |
| C146 10A008 000 2 | 27 | C146 10B003 002 4 | 18 | C146 10B025 005 2 | 31 | C146 10N010 509 1 | 181 |
| C146 10A008 500 2 | 27 | C146 10B003 102 3 | 102 | C146 10B025 060 2 | 29 | C146 10N010 600 2 | 177 |
| C146 10A008 500 15 | 78, 87 | C146 10B003 500 15 | 78, 83 | C146 10B025 500 2 | 29, 31 | C146 10N010 601 1 | 177 |
| C146 10A010 000 1 | 50 | C146 10B004 002 4 | 18 | C146 10B025 505 2 | 31 | C146 10N010 601 2 | 177 |
| C146 10A010 002 1 | 50 | C146 10B004 100 13 | 111 | C146 10B032 500 10 | 66 | C146 10N010 603 1 | 179 |
| C146 10A010 002 4 | 19 | C146 10B005 500 12 | 159 | C146 10B040 000 2 | 30 | C146 10N010 603 2 | 179 |
| C146 10A010 102 1 | 50 | C146 10B006 000 1 | 48 | C146 10B040 060 2 | 30 | C146 10N010 604 2 | 181 |
| C146 10A010 102 3 | 104 | C146 10B006 002 1 | 48 | C146 10B040 500 2 | 30 | C146 10N010 605 1 | 181 |
| C146 10A010 102 4 | 19 | C146 10B006 100 13 | 111 | C146 10B042 000 9 | 41 | C146 10N010 606 2 | 179 |
| C146 10A010 400 1 | 50 | C146 10B006 102 1 | 48 | C146 10B042 500 13 | 113 | C146 10N010 607 1 | 179 |
| C146 10A010 500 1 | 51 | C146 10B006 102 3 | 103 | C146 10B046 500 10 | 66 | C146 10N010 607 2 | 179 |
| C146 10A010 500 10 | 65 | C146 10B006 102 5 | 97 | C146 10B064 000 2 | 32, 33 | C146 10N010 609 1 | 181 |
| C146 10A010 810 1 | 72 | C146 10B006 400 1 | 48 | C146 10B064 005 2 | 33 | C146 10N010 609 2 | 181 |
| C146 10A012 500 15 | 79, 89 | C146 10B006 500 1 | 49 | C146 10B064 060 2 | 32 | C146 10N010 802 2 | 179 |
| C146 10A015 000 2 | 28 | C146 10B006 500 15 | 78, 85 | C146 10B064 500 2 | 32, 33 | C146 10N010 803 1 | 179 |
| C146 10A015 060 2 | 28 | C146 10B006 810 1 | 72 | C146 10B064 505 2 | 33 | C146 10N010 803 2 | 179 |
| C146 10A015 500 2 | 28 | C146 10B007 000 2 | 27 | C146 10B072 000 9 | 41 | C146 10N010 804 2 | 181 |
| C146 10A016 000 1 | 52 | C146 10B007 500 2 | 27 | C146 10B108 000 9 | 42 | C146 10N010 805 1 | 181 |
| C146 10A016 002 1 | 52 | C146 10B007 500 12 | 161 | C146 10B108 005 9 | 42 | C146 10N010 806 2 | 179 |
| C146 10A016 002 3 | 105 | C146 10B008 000 2 | 27 | C146 10F003 000 4 | 166 | C146 10N010 807 1 | 179 |
| C146 10A016 002 4 | 20, 21 | C146 10B008 500 2 | 27 | C146 10F003 004 4 | 166 | C146 10N010 807 2 | 179 |
| C146 10A016 004 4 | 21 | C146 10B008 500 15 | 78, 87 | C146 10F006 000 1 | 174 | C146 10N015 500 2 | 169 |
| C146 10A016 102 1 | 52 | C146 10B010 000 1 | 50 | C146 10F006 003 1 | 174 | C146 10N015 600 2 | 169 |
| C146 10A016 102 3 | 105, 106 | C146 10B010 002 1 | 50 | C146 10F010 000 1 | 176 | C146 10N015 606 2 | 169 |
| C146 10A016 102 4 | 20, 21 | C146 10B010 002 4 | 19 | C146 10F010 001 1 | 178 | C146 10N015 607 2 | 169 |
| C146 10A016 104 3 | 106 | C146 10B010 102 1 | 50 | C146 10F010 002 1 | 180 | C146 10N015 806 2 | 169 |
| C146 10A016 104 4 | 21 | C146 10B010 102 3 | 104 | C146 10F010 003 1 | 178 | C146 10N016 500 1 | 183 |
| C146 10A016 400 1 | 52 | C146 10B010 102 4 | 19 | C146 10F010 090 1 | 176 | C146 10N016 500 2 | 183 |
| C146 10A016 500 1 | 53 | C146 10B010 400 1 | 50 | C146 10F015 000 2 | 168 | C146 10N016 508 1 | 187 |
| C146 10A016 810 1 | 73 | C146 10B010 500 1 | 51 | C146 10F015 003 2 | 168 | C146 10N016 508 2 | 187 |
| C146 10A017 500 15 | 79, 91 | C146 10B010 500 10 | 65 | C146 10F016 000 1 | 183 | C146 10N016 600 1 | 183 |
| C146 10A018 500 10 | 65 | C146 10B010 810 1 | 72 | C146 10F016 001 1 | 184 | C146 10N016 600 2 | 183 |
| C146 10A020 500 15 | 79, 93 | C146 10B012 500 15 | 79, 89 | C146 10F016 002 1 | 186 | C146 10N016 601 2 | 183 |
| C146 10A024 000 1 | 54, 56 | C146 10B015 000 2 | 28 | C146 10F016 003 1 | 184 | C146 10N016 602 1 | 185 |
| C146 10A024 000 9 | 41 | C146 10B015 060 2 | 28 | C146 10F024 000 1 | 189 | C146 10N016 602 2 | 185 |
| C146 10A024 002 1 | 54, 56 | C146 10B015 500 2 | 28 | C146 10F024 000 3 | 197 | C146 10N016 603 2 | 185 |
| C146 10A024 005 1 | 56 | C146 10B016 000 1 | 52 | C146 10F024 001 1 | 190 | C146 10N016 604 1 | 187 |
| C146 10A024 102 1 | 54, 56 | C146 10B016 002 1 | 52 | C146 10F024 002 1 | 192 | C146 10N016 604 2 | 187 |

heavy|mate® Summary of Part Numbers

| Part Number | Page | Part Number | Page | Part Number | Page | Part Number | Page |
|--------------------|------|--------------------|------|-------------------|------|-------------------|------|
| C146 10N016 606 1 | 185 | C146 10R024 650 3 | 197 | C146 11R016 650 8 | 214 | C146 21R015 550 2 | 168 |
| C146 10N016 606 2 | 185 | C146 10R024 802 3 | 197 | C146 11R024 500 1 | 215 | C146 21R015 600 2 | 168 |
| C146 10N016 607 2 | 185 | C146 10R024 852 3 | 197 | C146 11R024 500 8 | 215 | C146 21R015 650 2 | 168 |
| C146 10N016 608 1 | 187 | C146 10R024 903 8 | 194 | C146 11R024 501 8 | 215 | C146 21R015 804 2 | 168 |
| C146 10N016 608 2 | 187 | C146 10R024 908 8 | 194 | C146 11R024 550 1 | 215 | C146 21R015 854 2 | 168 |
| C146 10N016 802 1 | 185 | C146 10S006 000 15 | 80 | C146 11R024 550 8 | 215 | C146 21R016 500 1 | 183 |
| C146 10N016 802 2 | 185 | C146 10S010 000 15 | 80 | C146 11R024 600 1 | 215 | C146 21R016 500 4 | 170 |
| C146 10N016 804 1 | 187 | C146 10S016 000 15 | 80 | C146 11R024 600 8 | 215 | C146 21R016 500 8 | 183 |
| C146 10N016 804 2 | 187 | C146 10S024 000 15 | 81 | C146 11R024 601 8 | 215 | C146 21R016 501 8 | 183 |
| C146 10N016 806 1 | 185 | C146 10Z000 002 8 | 155 | C146 11R024 650 1 | 215 | C146 21R016 502 1 | 186 |
| C146 10N016 806 2 | 185 | C146 10Z001 001 8 | 155 | C146 11R024 650 8 | 215 | C146 21R016 502 8 | 186 |
| C146 10N024 500 1 | 189 | C146 10Z002 001 8 | 155 | C146 21R006 506 1 | 174 | C146 21R016 503 8 | 186 |
| C146 10N024 500 2 | 189 | C146 10Z003 100 4 | 166 | C146 21R006 506 8 | 174 | C146 21R016 506 1 | 184 |
| C146 10N024 500 3 | 197 | C146 10Z006 100 1 | 175 | C146 21R006 507 1 | 174 | C146 21R016 506 8 | 184 |
| C146 10N024 508 1 | 193 | C146 10Z006 200 1 | 175 | C146 21R006 556 8 | 174 | C146 21R016 507 8 | 184 |
| C146 10N024 508 2 | 193 | C146 10Z010 100 1 | 182 | C146 21R006 606 1 | 174 | C146 21R016 550 1 | 183 |
| C146 10N024 600 1 | 189 | C146 10Z010 200 1 | 182 | C146 21R006 606 8 | 174 | C146 21R016 550 4 | 170 |
| C146 10N024 600 2 | 189 | C146 10Z015 100 2 | 169 | C146 21R006 656 1 | 174 | C146 21R016 552 1 | 186 |
| C146 10N024 600 3 | 197 | C146 10Z016 100 1 | 188 | C146 21R006 656 8 | 174 | C146 21R016 556 1 | 184 |
| C146 10N024 601 2 | 189 | C146 10Z016 200 1 | 188 | C146 21R006 804 1 | 174 | C146 21R016 600 1 | 183 |
| C146 10N024 602 1 | 191 | C146 10Z024 100 1 | 194 | C146 21R006 854 8 | 174 | C146 21R016 600 4 | 170 |
| C146 10N024 602 2 | 191 | C146 10Z024 200 1 | 194 | C146 21R010 500 1 | 176 | C146 21R016 600 8 | 183 |
| C146 10N024 604 1 | 193 | C146 10Z025 100 2 | 171 | C146 21R010 500 4 | 168 | C146 21R016 601 8 | 183 |
| C146 10N024 604 2 | 193 | C146 11F006 001 8 | 212 | C146 21R010 500 8 | 176 | C146 21R016 602 1 | 186 |
| C146 10N024 605 2 | 193 | C146 11F006 901 8 | 212 | C146 21R010 502 8 | 180 | C146 21R016 602 8 | 186 |
| C146 10N024 606 1 | 191 | C146 11F006 902 8 | 212 | C146 21R010 506 1 | 178 | C146 21R016 603 8 | 186 |
| C146 10N024 606 2 | 191 | C146 11F010 000 8 | 213 | C146 21R010 506 8 | 178 | C146 21R016 606 1 | 184 |
| C146 10N024 607 2 | 191 | C146 11F010 901 8 | 213 | C146 21R010 550 1 | 176 | C146 21R016 606 8 | 184 |
| C146 10N024 608 1 | 193 | C146 11F010 902 8 | 213 | C146 21R010 550 4 | 168 | C146 21R016 607 8 | 184 |
| C146 10N024 608 2 | 193 | C146 11F016 000 8 | 214 | C146 21R010 550 8 | 176 | C146 21R016 650 1 | 183 |
| C146 10N024 802 1 | 191 | C146 11F016 901 8 | 214 | C146 21R010 552 1 | 180 | C146 21R016 650 4 | 170 |
| C146 10N024 802 2 | 191 | C146 11F016 902 8 | 214 | C146 21R010 552 8 | 180 | C146 21R016 652 1 | 186 |
| C146 10N024 804 1 | 193 | C146 11F024 000 8 | 215 | C146 21R010 556 1 | 178 | C146 21R016 656 1 | 184 |
| C146 10N024 804 2 | 193 | C146 11F024 901 8 | 215 | C146 21R010 556 8 | 178 | C146 21R016 802 1 | 183 |
| C146 10N024 806 1 | 191 | C146 11F024 902 8 | 215 | C146 21R010 600 1 | 176 | C146 21R016 802 8 | 183 |
| C146 10N024 806 2 | 191 | C146 11R006 506 1 | 212 | C146 21R010 600 4 | 168 | C146 21R016 803 8 | 183 |
| C146 10N024 808 1 | 193 | C146 11R006 506 8 | 212 | C146 21R010 600 8 | 176 | C146 21R016 804 1 | 184 |
| C146 10N025 500 2 | 171 | C146 11R006 507 1 | 212 | C146 21R010 602 8 | 180 | C146 21R016 804 4 | 170 |
| C146 10N025 600 2 | 171 | C146 11R006 556 1 | 212 | C146 21R010 606 1 | 178 | C146 21R016 804 8 | 184 |
| C146 10N025 601 2 | 171 | C146 11R006 556 8 | 212 | C146 21R010 606 8 | 178 | C146 21R016 805 8 | 184 |
| C146 10N025 606 2 | 171 | C146 11R006 606 1 | 212 | C146 21R010 607 1 | 178 | C146 21R016 852 1 | 183 |
| C146 10N025 607 2 | 171 | C146 11R006 606 8 | 212 | C146 21R010 607 8 | 178 | C146 21R016 854 1 | 184 |
| C146 10N025 806 2 | 171 | C146 11R006 607 1 | 212 | C146 21R010 650 1 | 176 | C146 21R016 854 4 | 170 |
| C146 10N032 500 4 | 173 | C146 11R006 656 8 | 212 | C146 21R010 650 4 | 168 | C146 21R024 500 1 | 189 |
| C146 10N032 550 4 | 173 | C146 11R010 500 1 | 213 | C146 21R010 650 8 | 176 | C146 21R024 500 8 | 189 |
| C146 10N032 600 4 | 173 | C146 11R010 500 8 | 213 | C146 21R010 652 1 | 180 | C146 21R024 501 8 | 189 |
| C146 10N032 650 4 | 173 | C146 11R010 550 1 | 213 | C146 21R010 652 8 | 180 | C146 21R024 502 1 | 192 |
| C146 10N048 803 1 | 196 | C146 11R010 550 8 | 213 | C146 21R010 656 1 | 178 | C146 21R024 502 8 | 192 |
| C146 10N048 807 1 | 196 | C146 11R010 600 1 | 213 | C146 21R010 656 8 | 178 | C146 21R024 503 8 | 192 |
| C146 10P006 000 15 | 80 | C146 11R010 600 8 | 213 | C146 21R010 802 1 | 176 | C146 21R024 506 1 | 190 |
| C146 10P010 000 15 | 80 | C146 11R010 601 1 | 213 | C146 21R010 802 8 | 176 | C146 21R024 506 8 | 190 |
| C146 10P016 000 15 | 80 | C146 11R010 601 8 | 213 | C146 21R010 804 1 | 178 | C146 21R024 507 8 | 190 |
| C146 10P024 000 15 | 81 | C146 11R010 650 1 | 213 | C146 21R010 804 4 | 168 | C146 21R024 550 1 | 189 |
| C146 10R003 500 4 | 166 | C146 11R010 650 8 | 213 | C146 21R010 804 8 | 178 | C146 21R024 552 1 | 192 |
| C146 10R003 600 4 | 166 | C146 11R016 500 1 | 214 | C146 21R010 805 1 | 178 | C146 21R024 556 1 | 190 |
| C146 10R003 804 4 | 166 | C146 11R016 500 8 | 214 | C146 21R010 805 8 | 178 | C146 21R024 600 1 | 189 |
| C146 10R010 902 8 | 182 | C146 11R016 501 8 | 214 | C146 21R010 852 1 | 176 | C146 21R024 600 8 | 189 |
| C146 10R016 902 8 | 188 | C146 11R016 550 8 | 214 | C146 21R010 852 8 | 176 | C146 21R024 601 8 | 189 |
| C146 10R016 910 8 | 188 | C146 11R016 600 1 | 214 | C146 21R010 854 1 | 178 | C146 21R024 602 1 | 192 |
| C146 10R024 500 3 | 197 | C146 11R016 600 8 | 214 | C146 21R010 854 4 | 168 | C146 21R024 602 8 | 192 |
| C146 10R024 550 3 | 197 | C146 11R016 601 8 | 214 | C146 21R010 854 8 | 178 | C146 21R024 603 8 | 192 |
| C146 10R024 600 3 | 197 | C146 11R016 650 1 | 214 | C146 21R015 500 2 | 168 | C146 21R024 606 1 | 190 |

heavy|mate[®] Summary of Part Numbers

| Part Number | Page | Part Number | Page | Part Number | Page | Part Number | Page |
|-------------------|------|-------------------|----------|-------------------|-----------------------------------|----------------------|-------------------------|
| C146 21R024 606 8 | 190 | C146 67R010 500 1 | 201 | C146 H01 034 G8 | 151, 122 | N02 060 6118 001 | 129 |
| C146 21R024 607 8 | 190 | C146 67R010 600 1 | 201 | C146 H01 044 G8 | 151, 122 | N02 100 6121 002 | 127 |
| C146 21R024 650 1 | 189 | C146 67R016 500 8 | 202 | C146 H02 034 G8 | 151, 122 | N02 100 6122 002 | 127 |
| C146 21R024 652 1 | 192 | C146 67R016 600 8 | 202 | C146 H02 044 G8 | 151, 122 | N02 100 6123 002 | 127 |
| C146 21R024 656 1 | 190 | C146 67R024 501 8 | 203 | C146 N32 009 G1 | 228 | N06 080 0003 1 | 228 |
| C146 21R024 802 1 | 189 | C146 67R024 601 8 | 203 | C146 N32 015 G1 | 228 | N06 080 0003 2 | 228 |
| C146 21R024 802 8 | 189 | C146 68F006 001 1 | 206 | C146 N32 015 G2 | 228 | N06 080 0003 3 | 228 |
| C146 21R024 803 8 | 189 | C146 68F010 001 1 | 207 | C146 N32 025 G1 | 228 | N06 080 0003 4 | 228 |
| C146 21R024 804 1 | 190 | C146 68F016 001 1 | 208 | C146 N32 025 G2 | 228 | N07 045 0001 L | 228 |
| C146 21R024 804 8 | 190 | C146 68F024 001 1 | 209 | C146 N32 037 G1 | 228 | N15 006 000 9Z | 133, 135 |
| C146 21R024 805 8 | 190 | C146 68N006 500 2 | 206 | C146 N32 050 G1 | 228 | N15 010 000 7Z | 133, 135 |
| C146 21R024 852 1 | 189 | C146 68N010 500 2 | 207 | C146 N33 009 G1 | 228 | N15 043 0003 003 | 129, 131 |
| C146 21R024 854 1 | 190 | C146 68N016 501 2 | 208 | C146 N33 015 G1 | 228 | N16 025 0112 5X | 217 |
| C146 21R025 500 2 | 170 | C146 68N024 501 2 | 209 | C146 N33 025 G1 | 228 | N16 032 0112 5X | 217 |
| C146 21R025 550 2 | 170 | C146 68R006 500 8 | 206 | C146 N33 037 G1 | 228 | N16 040 0112 5X | 217 |
| C146 21R025 600 2 | 170 | C146 68R006 600 8 | 206 | C146 N33 050 G1 | 228 | N17 045 000 1 | 159 |
| C146 21R025 650 2 | 170 | C146 68R010 500 8 | 207 | C146 P06 001 G8 | 124 | N17 059 000 1 | 161 |
| C146 21R025 804 2 | 170 | C146 68R010 600 8 | 207 | C146 P06 002 G8 | 124 | N17 059 000 2 | 161 |
| C146 21R025 854 2 | 170 | C146 68R016 501 8 | 208 | C146 P10 001 G8 | 124 | TA 0000 | 36, 60, 61, 67, |
| C146 21R032 500 4 | 172 | C146 68R016 601 8 | 208 | C146 P10 002 G8 | 124 | | 85, 87, 93, 133, 135, |
| C146 21R032 502 4 | 172 | C146 68R024 501 8 | 209 | C146 P16 001 G8 | 124 | | 137, 139, 141, 143, 147 |
| C146 21R032 550 4 | 172 | C146 68R024 601 8 | 209 | C146 P16 002 G8 | 124 | TA 0000 121 | 137 |
| C146 21R032 552 4 | 172 | C146 A00 001 E8 | 155 | C146 P24 001 G8 | 125 | TA 0000 124 | 61, 67, 85, 87, |
| C146 21R032 600 4 | 172 | C146 A01 001 E8 | 118, 127 | C146 P24 002 G8 | 125 | | 93, 133, 135, 139 |
| C146 21R032 602 4 | 172 | C146 A02 001 E8 | 118, 129 | C146 P24 101 G8 | 125 | TA 0000 141 | 36, 60, 137, 141 |
| C146 21R032 650 4 | 172 | C146 A02 801 E8 | 118, 131 | C146 P24 102 G8 | 125 | TA 0000 144 | 61, 67, 85, 87, |
| C146 21R032 652 4 | 172 | C146 A03 001 E8 | 119, 135 | C146 S06 001 G8 | 124 | | 93, 133, 135, 139 |
| C146 21R032 802 4 | 172 | C146 A03 501 E8 | 121, 147 | C146 S06 002 G8 | 124 | TA 0000 163 | 36, 60, 137, 141 |
| C146 21R032 852 4 | 172 | C146 A03 801 E8 | 119, 133 | C146 S10 001 G8 | 124 | TA 0000 180 | 133, 135 |
| C146 21R048 507 1 | 195 | C146 A05 001 E8 | 120, 139 | C146 S10 002 G8 | 124 | TA 0000 184 | 143, 153 |
| C146 21R048 508 1 | 195 | C146 A05 100 G8 | 122, 153 | C146 S16 001 G8 | 124 | TA 0000 202 | 36, 141 |
| C146 21R048 607 1 | 195 | C146 A08 102 E8 | 122, 153 | C146 S16 002 G8 | 124 | TA 0000 401 | 147 |
| C146 21R048 608 1 | 195 | C146 A10 001 E8 | 120, 143 | C146 S24 001 G8 | 125 | TA 0000 402 | 147 |
| C146 30F003 000 4 | 167 | C146 A20 001 G8 | 121, 145 | C146 S24 002 G8 | 125 | TA 0000 oder TA 0500 | 153 |
| C146 30F003 004 4 | 167 | C146 B00 001 E8 | 155 | C146 S24 101 G8 | 125 | TA 0001 146 000 1 | 36, 141 |
| C146 30F006 003 1 | 174 | C146 B01 004 E1 | 118 | C146 S24 102 G8 | 125 | TA 0002 146 000 1 | 36, 141 |
| C146 30F010 003 1 | 178 | C146 B01 004 E8 | 127 | FG 0200 146 1 | 60, 137, 154 | TA 0003 146 000 1 | 137 |
| C146 30F016 003 1 | 184 | C146 B02 001 E8 | 118, 129 | FG 0300 146 1 | 36, 37, 43, | TA 0004 146 000 1 | 60, 137 |
| C146 30F024 003 1 | 190 | C146 B02 801 E8 | 118, 131 | | 89, 91, 143, 141, 153, 154 | TA 0005 146 000 3 | 60, 137 |
| C146 30N003 500 4 | 167 | C146 B03 001 E8 | 119, 135 | FG 1000 146 | 141 | TA 0007 146 000 3 | 36, 141 |
| C146 30R003 500 4 | 167 | C146 B03 501 E8 | 147 | FG 0300 146 3 | 131, 133, | TA 0010 146 000 1 | 143, 153 |
| C146 30R003 600 4 | 167 | C146 B03 801 E8 | 119, 133 | | 135, 147, 154 | TA 0010 146 000 2 | 133, 139 |
| C146 30R003 804 4 | 167 | C146 B05 001 E8 | 120, 139 | FG 0300 146 4 | 139, 154 | TA 0010 146 000 3 | 139 |
| C146 30Z003 100 4 | 167 | C146 B05 100 G8 | 122, 153 | FG 0300 146 7 | 61, 67, | TA 0010 146 000 4 | 133, 135 |
| C146 50F006 000 1 | 218 | C146 B08 102 E8 | 122, 153 | | 85, 87, 93 | TA 0010 146 000 5 | 135 |
| C146 50F010 000 1 | 219 | C146 B10 001 E8 | 120, 143 | FG 1000 146 | 131, 133, 135, | TA 0010 146 000 6 | 61 |
| C146 50F016 000 1 | 220 | C146 B20 001 G8 | 121 | | 137, 139, 141, 143, 145, 147, 155 | TA 0010 146 000 6 | 67, 85, |
| C146 50F024 000 1 | 221 | C146 B20 001 G8 | 145 | .N01 016 0002 (1) | 34 | | 87, 93 |
| C146 50R006 507 1 | 218 | C146 C04 001 E8 | 119, 137 | .N01 016 0003 (1) | 34 | TA 0010 146 000 7 | 61, 67, |
| C146 50R006 607 1 | 218 | C146 C05 001 E8 | 119, 137 | .N01 016 0005 (1) | 34 | | 85, 87, 93 |
| C146 50R010 500 1 | 219 | C146 C05 801 E8 | 119, 137 | N01 016 0040 8 | 234 | TA 0100 146 | 36, 37, 43, |
| C146 50R010 600 1 | 219 | C146 C10 001 G8 | 120, 141 | N01 025 0001 (1) | 58 | | 89, 91, 141 |
| C146 50R016 500 8 | 220 | C146 D04 001 E8 | 119, 137 | N01 025 0010 (1) | 58 | TA 0200 146 | 145 |
| C146 50R016 600 8 | 220 | C146 D05 001 E8 | 119, 137 | N01 060 0004 1 | 129 | TA 0500 | 36, 61, 67, |
| C146 50R024 501 8 | 221 | C146 D05 801 E8 | 119, 137 | N01 060 0007 1 | 129 | | 85, 87, 93 |
| C146 50R024 601 8 | 221 | C146 D10 001 E8 | 120, 141 | N01 060 0008 1 | 129 | TB 0200 146 | 133, 135 |
| C146 67F006 000 8 | 200 | C146 E12 001 E8 | 121, 149 | N01 100 6001 001 | 127 | TB 0500 146 | 143 |
| C146 67F010 000 8 | 201 | C146 F12 001 G8 | 121, 149 | N01 100 6002 001 | 127 | TB 0600 146 | 60, 61, 67, |
| C146 67F016 000 8 | 202 | C146 G01 014 G8 | 122, 151 | N01 100 6003 001 | 127 | | 85, 87, 93 |
| C146 67F024 000 8 | 203 | C146 G01 024 G8 | 151, 122 | N02 016 0040 8 | 234 | TE 0500 103 | 127 |
| C146 67R006 507 1 | 200 | C146 G02 014 G8 | 151, 122 | N02 060 6114 001 | 129 | TE 0500 201 | 127 |
| C146 67R006 607 1 | 200 | C146 G02 024 G8 | 151, 122 | N02 060 6117 001 | 129 | TE 0500 301 | 127 |

heavy|mate® Summary of Part Numbers

| Part Number | Page | Part Number | Page | Part Number | Page | Part Number | Page |
|----------------------------|----------|-----------------------|-----------|-----------------------|----------|----------------------|---------|
| TE 0600 022 | 129 | VN01 016 0027 (1)C | 37, 43, | VN01 040 0010 1C | 83, 113 | VN02 025 0037 (1)C | 61, 67, |
| TE 0600 042 | 129 | 89, 91, 143, 149, 233 | | VN01 040 0011 1C | 83, 113 | 85, 87, 93, 159, 233 | |
| TE 0600 062 | 129 | VN01 016 0027 1C | 113, 161 | VN01 040 0012 1C | 83, 113 | VN02 025 0037 (2)C | 61, 67, |
| TE 0600 063 | 131 | VN01 016 0027 (2)C | 37, 43, | VN01 040 0013 1C | 83, 113 | 85, 87, 93, 159 | |
| TN01 010 0130 (2) | 145 | 89, 91, 143, 149 | | VN02 010 0130 (2) | 145 | VN02 025 0038 (1)C | 61, 67, |
| TN01 010 0131 (2) | 145 | VN01 016 0027 2C | 153, 161 | VN02 010 0131 (2) | 145 | 85, 87, 93, 159, 233 | |
| TN01 016 0002 (1) | 36, 141 | VN01 016 0028 (1)C | 37, 43, | VN02 016 0002 (1) | 36, 141 | VN02 025 0038 (2)C | 61, 67, |
| TN01 016 0002 (2) | 36, 141 | 89, 91, 143, 149, 233 | | VN02 016 0002 (2) | 36, 141 | 85, 87, 93, 159 | |
| TN01 016 0003 (1) | 36, 141 | VN01 016 0028 1C | 113, 161 | VN02 016 0003 (1) | 36, 141 | VN02 025 0039 (1)C | 61, 67, |
| TN01 016 0003 (2) | 36, 141 | VN01 016 0028 (2)C | 37, 43, | VN02 016 0003 (2) | 36, 141 | 85, 87, 93, 159, 233 | |
| TN01 016 0005 (1) | 36, 141 | 89, 91, 143, 149 | | VN02 016 0005 (1) | 36, 141 | VN02 025 0039 (2)C | 61, 67, |
| TN01 016 0005 (2) | 36, 141 | VN01 016 0028 2C | 153, 161 | VN02 016 0005 (2) | 36, 141 | 85, 87, 93, 159 | |
| TN01 016 0015 (1) | 36, 141 | VN01 016 0040 (8) X | 143 | VN02 016 0015 (1) | 36 | VN02 025 0043 (1) | 137 |
| TN01 016 0016 (1) | 36, 141 | VN01 025 0001 (101) | 60, 137 | VN02 016 0016 (1) | 36 | VN02 036 0001 (1)C | 133, |
| TN01 025 0001 (1) | 60, 137 | VN01 025 0001 (102) | 60, 137 | VN02 016 0024 (1)C | 37, 43, | 135, 233 | |
| TN01 025 0001 (2) | 137 | VN01 025 0010 (101) | 60, 137 | 89, 91, 143, 149, 233 | | VN02 036 0002 (1)C | 133, |
| TN01 025 0010 (1) | 60, 137 | VN01 025 0010 (102) | 60, 137 | VN02 016 0024 1C | 113, 161 | 135, 233 | |
| TN01 025 0010 (2) | 137 | VN01 025 0029 (1)C | 139, 233 | VN02 016 0024 (2)C | 37, 43, | VN02 036 0003 (1)C | 133, |
| TN01 025 0043 (1) | 137 | VN01 025 0030 (1)C | 139, 233 | 89, 91, 143, 149 | | 135, 233 | |
| TN02 010 0130 (2) | 145 | VN01 025 0031 (1)C | 139, 233 | VN02 016 0024 2C | 153, 161 | VN02 036 0004 (1)C | 133, |
| TN02 010 0131 (2) | 145 | VN01 025 0032 (1)C | 139, 233 | VN02 016 0025 (1)C | 37, 43, | 135, 233 | |
| TN02 016 0002 (1) | 36, 141 | VN01 025 0033 (1)C | 139, 233 | 89, 91, 143, 149, 233 | | VN02 036 0005 (1)C | 133, |
| TN02 016 0002 (2) | 36, 141 | VN01 025 0035 (1)C | 61, 67, | VN02 016 0025 1C | 113, 161 | 135, 233 | |
| TN02 016 0003 (1) | 36, 141 | 85, 87, 93, 233 | | VN02 016 0025 (2)C | 37, 43, | VN02 036 0021 1C | 131 |
| TN02 016 0003 (2) | 36, 141 | VN01 025 0035 1C | 159 | 89, 91, 143, 149 | | VN02 040 0010 1C | 83, 113 |
| TN02 016 0005 (1) | 36, 141 | VN01 025 0035 (2)C | 61, 67, | VN02 016 0025 2C | 153, 161 | VN02 040 0011 1C | 83, 113 |
| TN02 016 0005 (2) | 36, 141 | 85, 87, 93 | | VN02 016 0026 (1)C | 37, 43, | VN02 040 0012 1C | 83, 113 |
| TN02 016 0015 (1) | 36, 141 | VN01 025 0035 2C | 159 | 89, 91, 143, 149, 233 | | VN02 040 0013 1C | 83, 113 |
| TN02 016 0016 (1) | 36, 141 | VN01 025 0036 (1)C | 61, 67, | VN02 016 0026 1C | 113, 161 | VN03 030 0020 | 226 |
| TN02 025 0001 (1) | 60, 137 | 85, 87, 93, 233 | | VN02 016 0026 (2)C | 37, 43, | VN03 030 0021 | 226 |
| TN02 025 0001 (2) | 137 | VN01 025 0036 1C | 159 | 89, 91, 143, 149 | | VN03 030 3000 X | 226 |
| TN02 025 0001 (2) | 137 | VN01 025 0036 (2)C | 61, 67, | VN02 016 0026 2C | 153, 161 | VN13 040 0008 (1) X | 226 |
| TN02 025 0010 (1) | 60, 137 | 85, 87, 93 | | VN02 016 0027 (1)C | 37, 43, | VN13 040 0009 (1) X | 226 |
| TN02 025 0010 (2) | 137 | VN01 025 0036 2C | 159 | 89, 91, 143, 149, 233 | | VN16 020 0113 (1) X | 225 |
| TN02 025 0043 (1) | 137 | VN01 025 0037 (1)C | 61, 67, | VN02 016 0027 1C | 113, 161 | VN16 025 0113 (1) X | 225 |
| VN01 010 0130 (2) | 145 | 85, 87, 93, 233 | | VN02 016 0027 (2)C | 37, 43, | VN16 032 0113 (1) X | 225 |
| VN01 010 0131 (2) | 145 | VN01 025 0037 1C | 159 | 89, 91, 143, 149 | | VN16 040 0113 (1) X | 225 |
| VN01 016 0002 (1) | 36, 141 | VN01 025 0037 (2)C | 61, 67, | VN02 016 0027 2C | 153, 161 | VN16 160 0102 V | 224 |
| VN01 016 0002 (2) | 36, 141 | 85, 87, 93 | | VN02 016 0028 (1)C | 37, 43, | VN16 160 0126 X | 225 |
| VN01 016 0003 (1) | 36, 141 | VN01 025 0037 2C | 159 | 89, 91, 143, 149, 233 | | VN16 160 0127 X | 225 |
| VN01 016 0003 (2) | 36, 141 | VN01 025 0038 (1)C | 61, 67, | VN02 016 0028 1C | 113, 161 | VN16 200 0102 V | 224 |
| VN01 016 0005 (1) | 36, 141 | 85, 87, 93, 233 | | VN02 016 0028 (2)C | 37, 43, | VN16 200 0103 V | 224 |
| VN01 016 0005 (2) | 36, 141 | VN01 025 0038 1C | 61, 67, | 89, 91, 143, 149 | | VN16 200 0114 X | 224 |
| VN01 016 0015 (1) | 36 | 85, 87, 93 | | VN02 016 0028 2C | 153, 161 | VN16 200 0114 X | 224 |
| VN01 016 0016 (1) | 36 | VN01 025 0038 2C | 159 | VN02 016 0040 (8) X | 143 | VN16 200 0126 X | 225 |
| VN01 016 0024 (1)C | 37, 43, | VN01 025 0039 (1)C | 61, 67, | VN02 025 0001 (101) | 60, 137 | VN16 200 0127 X | 225 |
| 89, 91, 143, 149, 233 | | 85, 87, 93, 233 | | VN02 025 0001 (102) | 60, 137 | VN16 250 0102 V | 224 |
| VN01 016 0024 1C | 113, 161 | VN01 025 0039 1C | 159 | VN02 025 0010 (101) | 60, 137 | VN16 250 0103 V | 224 |
| VN01 016 0024 (2)C | 37, 43, | VN01 025 0039 (2)C | 61, 67, | VN02 025 0010 (102) | 60, 137 | VN16 250 0114 X | 224 |
| 89, 91, 143, 149 | | 85, 87, 93 | | VN02 025 0029 (1)C | 139, 233 | VN16 250 0126 X | 225 |
| VN01 016 0024 2C | 153, 161 | VN01 025 0039 2C | 159 | VN02 025 0030 (1)C | 139, 233 | VN16 250 0127 X | 225 |
| VN01 016 0025 (1)C | 37, 43, | VN01 025 0043 (1) | 137 | VN02 025 0031 (1)C | 139, 233 | VN16 320 0102 V | 224 |
| 89, 91, 143, 149, 233 | | VN01 036 0001 (1)C | 133, 135, | VN02 025 0032 (1)C | 139, 233 | VN16 320 0103 V | 224 |
| VN01 016 0025 1C | 113, 161 | 233 | | VN02 025 0033 (1)C | 139, 233 | VN16 320 0114 X | 224 |
| VN01 016 0025 (2)C | 37, 43, | VN01 036 0002 (1)C | 135, 233 | VN02 025 0035 (1)C | 61, 67, | VN16 320 0126 X | 225 |
| 89, 91, 143, 149, 153, 161 | | VN01 036 0003 (1)C | 133, 135, | 85, 87, 93, 159, 233 | | VN16 320 0127 X | 225 |
| VN01 016 0026 (1)C | 37, 43, | 233 | | VN02 025 0035 (2)C | 61, 67, | VN16 400 0114 X | 224 |
| 89, 91, 143, 149, 233 | | VN01 036 0004 (1)C | 133, 135, | 85, 87, 93, 159 | | VN16 400 0126 X | 225 |
| VN01 016 0026 1C | 113, 161 | 233 | | VN02 025 0036 (1)C | 61, 67, | VN16 400 0127 X | 225 |
| VN01 016 0026 (2)C | 37, 43, | VN01 036 0005 (1)C | 133, 135, | 85, 87, 93, 159, 233 | | VN16 500 0114 X | 224 |
| 89, 91, 143, 149 | | 233 | | VN02 025 0036 (2)C | 61, 67, | VN17 050 0004 (1) | 226 |
| VN01 016 0026 2C | 153, 161 | VN01 036 0021 1C | 131 | 85, 87, 93, 159 | | VN17 050 0004 (101) | 226 |

heavy|mate[®] Summary of Part Numbers

| Part Number | Page |
|-------------------|---------|
| ZN01 010 0130 (2) | 145 |
| ZN01 010 0131 (2) | 145 |
| ZN01 016 0002 (1) | 36, 141 |
| ZN01 016 0002 (2) | 36, 141 |
| ZN01 016 0003 (1) | 36, 141 |
| ZN01 016 0003 (2) | 36, 141 |
| ZN01 016 0005 (1) | 36, 141 |
| ZN01 016 0005 (2) | 36, 141 |
| ZN01 016 0015 (1) | 36, 141 |
| ZN01 016 0016 (1) | 36, 141 |
| ZN01 025 0001 (1) | 60 |
| ZN01 025 0001 (2) | 60 |
| ZN01 025 0010 (1) | 60 |
| ZN01 025 0010 (2) | 60 |
| ZN02 010 0130 (2) | 145 |
| ZN02 010 0131 (2) | 145 |
| ZN02 016 0002 (1) | 36, 141 |
| ZN02 016 0002 (2) | 36, 141 |
| ZN02 016 0003 (1) | 36, 141 |
| ZN02 016 0003 (2) | 36, 141 |
| ZN02 016 0005 (1) | 36, 141 |
| ZN02 016 0005 (2) | 36, 141 |
| ZN02 016 0015 (1) | 36, 141 |
| ZN02 016 0016 (1) | 36, 141 |
| ZN02 025 0001 (1) | 60 |
| ZN02 025 0001 (2) | 60 |
| ZN02 025 0010 (1) | 60 |
| ZN02 025 0010 (2) | 60 |

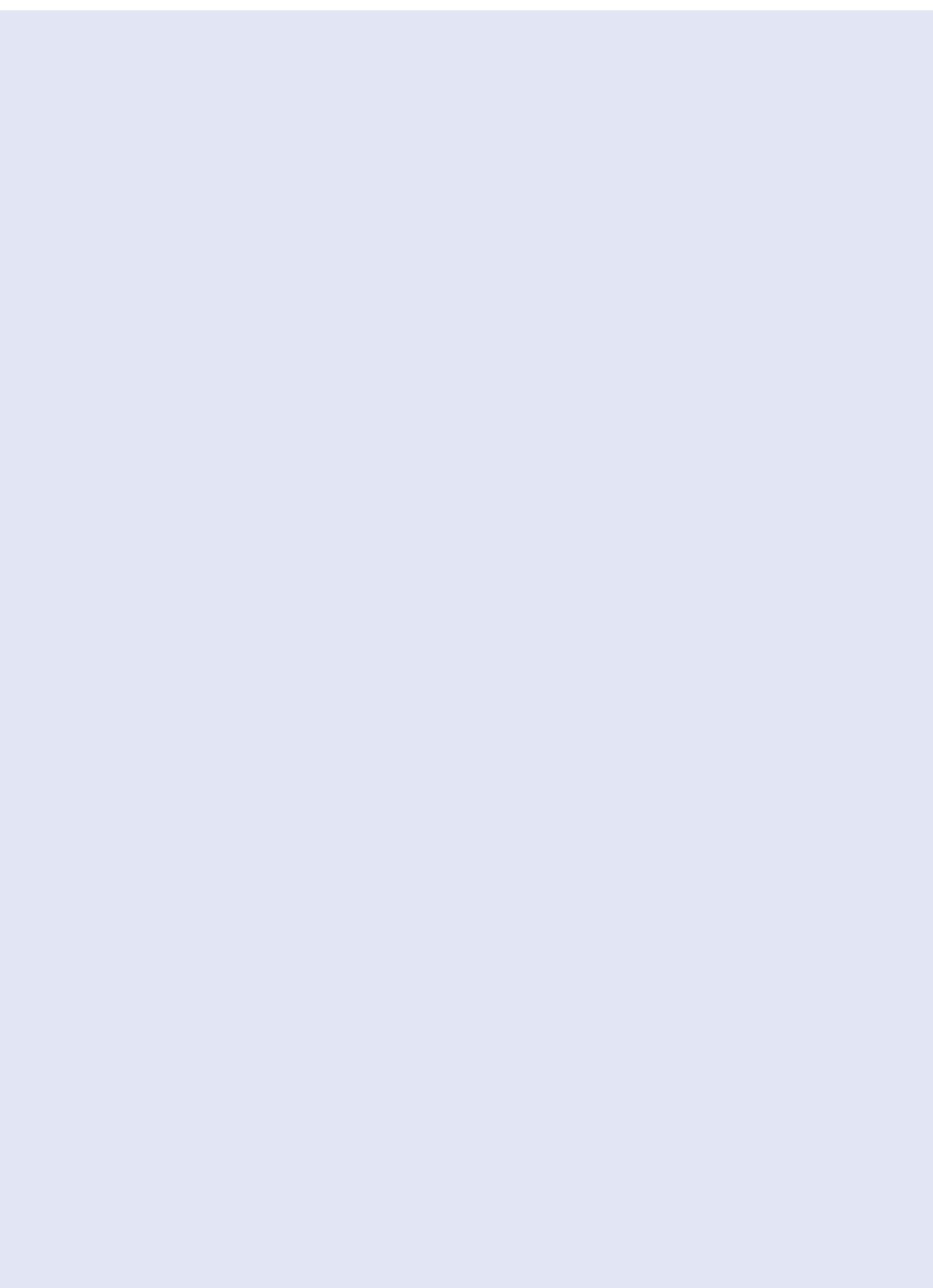

International

Argentina

Amphenol Argentina
Av. Callao 930
2nd Floor Office B "Plaza"
C1023 AAP Buenos Aires
Phone +54 11 4815 68 86
www.amphenol.com.ar

Australia

Amphenol Australia Pty. Ltd.
2 Fiveways Blvd
Keysborough
Victoria 31 73
Phone +61 3 8796 88 88
www.amphenol.com.au

Brazil

Amphenol do Brasil Ltda.
Rua Diogo Moreira 132, 20th Floor
CEP 05423-101 Sao Paulo SP
Phone +55 11 3815 10 03
www.amphenol.com.br

China

Amphenol-Tuchel Electronics
China Branch
20 Taishan Road
Changzhou 213022
Phone +86 0519 511 03 01
www.amphenol.info

France

Amphenol Socapex S.A.S.
948, Promenade de l'Arve, BP 29
Thyez Cedex, 74311
Phone +33 4 5089 28 00
www.amphenol-socapex.com

Germany

Amphenol-Tuchel Electronics GmbH
August-Haeusser-Str. 10
74080 Heilbronn
Phone +49 7131 929 0
www.amphenol.de

India

Amphenol Interconnect India Pvt Ltd
105, Bhosari Industrial Area
Pune - 411 026
Phone +91 20 2712 04 81
www.amphenol-in.com

Italy

Amphenol-Tuchel Italy
Via Barbaiana n. 5
20020 Lainate (MI)
Phone +39 02 9325 41
www.amphenol.info

Korea

Amphenol DaeShin Elect and
Precision Co.,Ltd
558 Songnae-Dong, Sosa-Gu
Bucheon-City, Kyunggi-Do
Korea 422-130
Phone +82 32 6103 800
www.amphenol.co.kr

Mexico

Amphenol Mexico
Prolongacion Reforma 61 - 6 B2
Col. Paseo de las Lomas
C.P. 01330 Mexico D.F.
Phone +52 55 5258 99 84
www.amphenolmexico.com

Singapore

Asia Pacific Sales Operations
72 Bendemeer Rd, No.03-32/33
Hiap Huat House, Luzerne, 339941
Singapore
Phone +65 6294 2128
www.amphenol.com

South Africa

Amphenol International Ltd
Chislehurst
30 Impala Road
2196 Chislehurst
Sandton, 2146
Phone +27 11 7839 517
www.amphenol.co.za

Spain

Amphenol Espana
Edificio Burgosal, Oficina 55
C/Comunidad de Madrid, 35 bis
Las Rozas (Madrid), 28230
Phone +34 91 6407 302
www.amphenol.com

Taiwan

Amphenol East Asia Limited-Taiwan
5F, No. 361, Fusing 1st Rd
Gueishan Township,
Taoyuan County 333
Phone +886 3 2647 200
www.amphenol.com

Amphenol LTW Technology Co., Ltd.
9F, No. 657-12, Zhongzheng Road
Xinzhuang Dist., New Taipei City
242 Taiwan
Phone +886 2 2908 5626
sales@ltw-tech.com
www.amphenolltw.com

Turkey

Amphenol Turkey
Sun Plaza Kat: 15
Maslak Mah. Bilim Sok.No:15
34398 Sisli - Istanbul
Phone: +90 2123 679 220
www.amphenol.com.tr

United Kingdom

Amphenol Limited
Thanet Way, Whitstable
Kent, CT53JF
Phone +44 1227 773 200
www.amphenol.co.uk

USA

Amphenol-Tuchel Electronics
6900 Haggerty Road
Suite 200
Canton, Michigan 48187
Phone +1 7344 516 400
www.amphenol.info

Amphenol Corporation
Corporate Headquarters
358 Hall Avenue
Wallingford, CT 06492
Phone +1 877 2674 366
Phone +1 203 2658 900
www.amphenol.com

More Amphenol companies can be
found here: www.amphenol.com



Important Notice

All technical data have been measured in a laboratory environment and can be different during practical usage of the product. Any product information is for descriptive usage only and not legally binding; particularly the information does not constitute or provide any legal guaranties ("Beschaffensgarantie" or "Haltbarkeitsgarantie").

We reserve the right to change the design due to improvement in quality, development or production requirements. This catalogue must not be used in any form or manner without our prior approval in writing (Copyright Law, Fair Trading Law, Civil Code).

Your engineering sales representative:

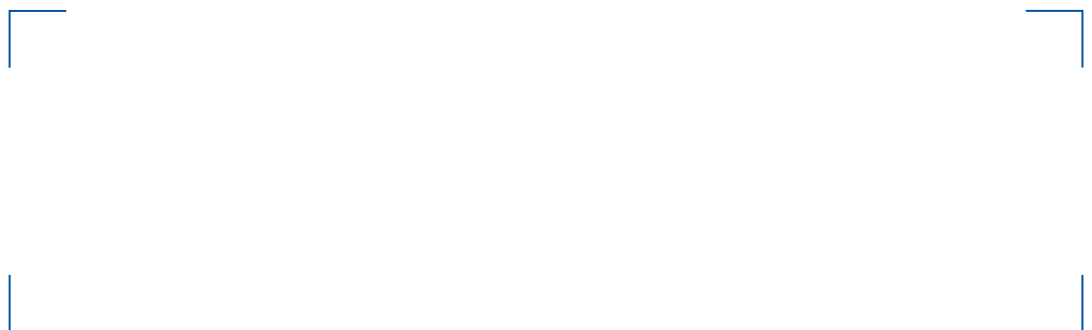



Компания «ЭлектроПласт» предлагает заключение долгосрочных отношений при поставках импортных электронных компонентов на взаимовыгодных условиях!

Наши преимущества:

- Оперативные поставки широкого спектра электронных компонентов отечественного и импортного производства напрямую от производителей и с крупнейших мировых складов;
- Поставка более 17-ти миллионов наименований электронных компонентов;
- Поставка сложных, дефицитных, либо снятых с производства позиций;
- Оперативные сроки поставки под заказ (от 5 рабочих дней);
- Экспресс доставка в любую точку России;
- Техническая поддержка проекта, помощь в подборе аналогов, поставка прототипов;
- Система менеджмента качества сертифицирована по Международному стандарту ISO 9001;
- Лицензия ФСБ на осуществление работ с использованием сведений, составляющих государственную тайну;
- Поставка специализированных компонентов (Xilinx, Altera, Analog Devices, Intersil, Interpoint, Microsemi, Aeroflex, Peregrine, Syfer, Eurofarad, Texas Instrument, Miteq, Cobham, E2V, MA-COM, Hittite, Mini-Circuits, General Dynamics и др.);

Помимо этого, одним из направлений компании «ЭлектроПласт» является направление «Источники питания». Мы предлагаем Вам помощь Конструкторского отдела:

- Подбор оптимального решения, техническое обоснование при выборе компонента;
- Подбор аналогов;
- Консультации по применению компонента;
- Поставка образцов и прототипов;
- Техническая поддержка проекта;
- Защита от снятия компонента с производства.



Как с нами связаться

Телефон: 8 (812) 309 58 32 (многоканальный)

Факс: 8 (812) 320-02-42

Электронная почта: org@eplast1.ru

Адрес: 198099, г. Санкт-Петербург, ул. Калинина, дом 2, корпус 4, литера А.