

# Sine Wave and EMC Output Filter for Motor Drives with a Voltage dc Link



- ▮ Smoothing of PWM drive output voltage
- ▮ Efficient motor protection
- ▮ Reduction of common-mode interferences on motor cables
- ▮ Improvement of EMC environment
- ▮ Elimination of motor bearing damages
- ▮ Possibility to use very long unshielded motor cables
- ▮ Improvement of system reliability



### Performance indicators

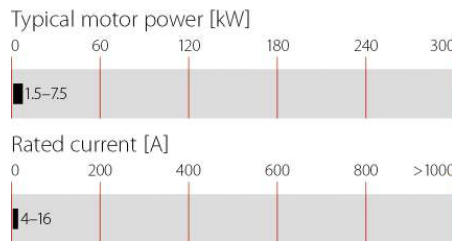

## Technical specifications

<b>Current in +/- control loop</b>	1 to 2 A approx.
<b>dc link voltage</b>	850 VDC max.
<b>Design corresponding to</b>	UL 1283, CSA 22.2 No. 8 1986, IEC/EN 60939
<b>Flammability corresponding to</b>	UL 94 V-2 or better
<b>High potential test voltage</b>	P → E 2500 VDC for 2 sec P → P 1100 VDC for 2 sec
<b>Motor cable length</b>	1000 m max.
<b>Motor frequency</b>	0 to 200 Hz
<b>MTBF @ 40°C/400V (Mil-HB-217F)</b>	>100,000 hours
<b>Nominal operating voltage</b>	3x 500/288 VAC
<b>Overload capability</b>	1.4x rated current for 1 minute, every 15 minutes
<b>Protection category</b>	IP20
<b>Rated currents</b>	4 to 16 A @ 40 °C
<b>Residual ripple voltage</b>	<5%
<b>Switching frequency</b>	6 to 20 kHz
<b>Temperature range (operation and storage)</b>	-25 °C to +100 °C (25/100/21)
<b>Voltage drop</b>	≤10 V @ 50 Hz

### Approvals

### ROHS



### Features and benefits

- ▮ Conversion of the PWM output signal (differential and common-mode voltage components) of motor drives into a smooth sine wave with low residual ripple
- ▮ Elimination of premature motor damage caused by high dv/dt, overvoltages, motor overheating, eddy current losses or bearing damage
- ▮ Elimination of interference propagation towards components or conductors in the vicinity
- ▮ Provision of all benefits of traditional LC sine wave filters, plus:
- ▮ Allows the use of extremely long unshielded motor cables without causing radiation problems (EN 55014, MDS clamp)
- ▮ Restricts pulse currents to ground and hence limits leakage currents in the PE
- ▮ Reduces the required EMI suppression efforts on the line side
- ▮ Allows the use of lower rated drives with long motor cables due to lower losses in the IGBTs and in the motor cable

### Typical applications

- ▮ Motor drive applications with extremely long motor cables
- ▮ Motor drive applications with unshielded motor cables
- ▮ Chemical and petro-chemical applications
- ▮ Semi-conductor manufacturing
- ▮ Mission critical applications
- ▮ Applications with multiple motors in parallel
- ▮ Retrofit of motor drives into existing installations with old wiring and motors

## Filter selection table

Filter	Rated current @ 40 °C	Typical motor power rating*	Typical power loss**	Input connections	Output connections	Weight
	[A]	[kW]	[W]			[kg]
<b>FN 530-4-99</b>	4	1.5	15	-29	-99	11.5
<b>FN 530-8-99</b>	8	3.0	33	-29	-99	15
<b>FN 530-12-99</b>	12	5.5	50	-29	-99	18.5
<b>FN 530-16-99</b>	16	7.5	37	-33	-99	21

\* General purpose four-pole (1500 r/min) AC induction motor rated 400 V/50 Hz.

\*\* Exact value depends upon the motor cable type and length, switching frequency, motor frequency and further stray parameters within the system.

## Typical block schematic

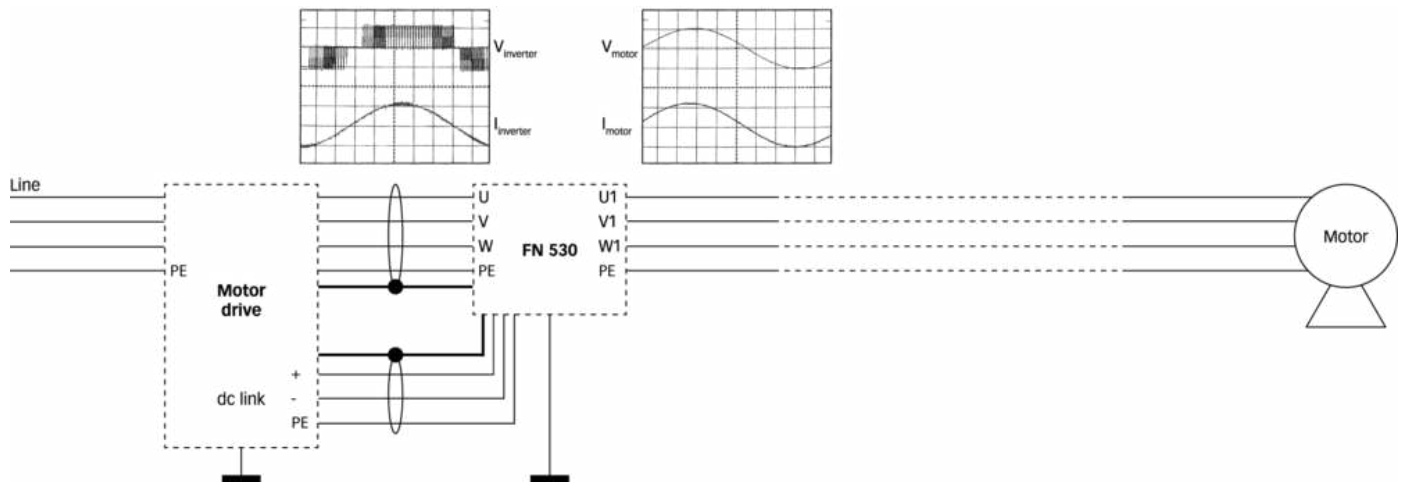

## Connection to the dc link

For best results, the connection to the dc link of the motor drive is required with this series of filters.

If only one connection to the dc link is brought out of the drive («+» or «-») then the dc link cable connections from the filter (identified by «DC+» and «DC-») must be connected together to the «+» or «-» motor drive connection.

The operation of the sine wave interference filter is not seriously affected as a result. The «+» and «-» connections on the motor drive must never be connected together. Otherwise a short-circuit will result.

The PWM switching frequency must lie within the range from 6 to 20kHz in order to ensure satisfactory operation of the filter. A lower switching frequency or a pure square wave is unsuitable and will result in the motor drive switching off with the error message «overcurrent or short to earth.»

For additional information please refer to the Schaffner application note "Sine Wave Filter Solutions for Motor Drives Applications" available on the homepage [www.schaffner.com/downloads](http://www.schaffner.com/downloads)

### Mechanical data

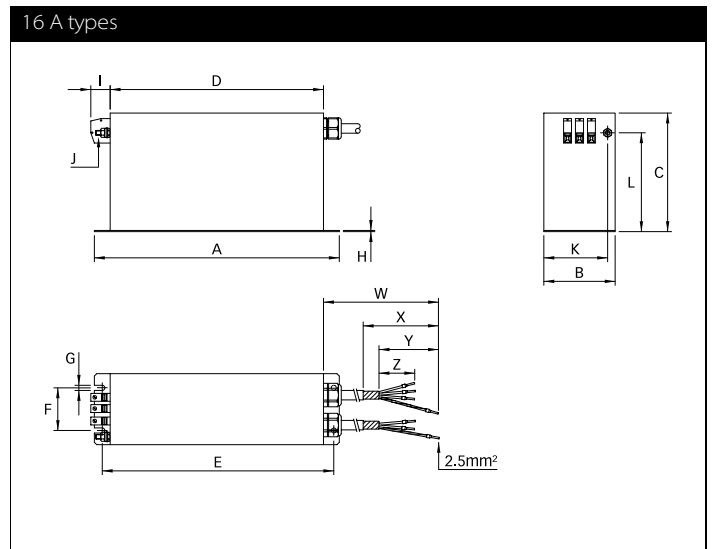
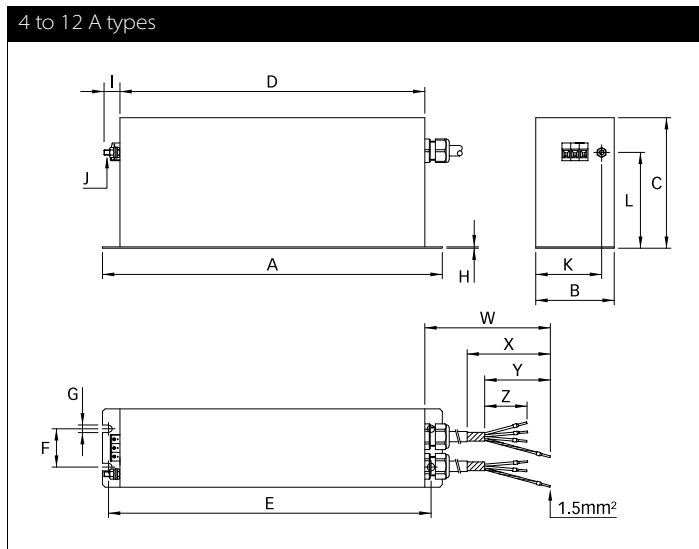

### Dimensions

	<b>4 A</b>	<b>8 A</b>	<b>12 A</b>	<b>16 A</b>
<b>A</b>	390	390	390	350
<b>B</b>	90	90	90	140
<b>C</b>	150	180	215	230
<b>D</b>	350	350	350	310
<b>E</b>	373	370	370	330
<b>F</b>	44	44	44	95
<b>G</b>	6.5	8.7	8.7	8.7
<b>H</b>	1.5	1.5	1.5	2.3
<b>I</b>	19	19	19	25
<b>J</b>	M6	M6	M6	M6
<b>K</b>	75	75	75	107.5
<b>L</b>	107	137	172	181
<b>W</b>	720 +15/-0	720 +15/-0	720 +15/-0	720 +15/-0
<b>X</b>	120	120	120	120
<b>Y</b>	100	100	100	100
<b>Z</b>	70	70	70	70

All dimensions in mm; 1 inch = 25.4 mm  
Tolerances according: ISO 2768-m / EN 22768-m

### Filter input connector cross sections

	<b>-29</b>	<b>-33</b>
<b>Solid wire</b>	 6 mm <sup>2</sup>	 16 mm <sup>2</sup>
<b>Flex wire</b>	4 mm <sup>2</sup>	10 mm <sup>2</sup>
<b>AWG type wire</b>	AWG 10	AWG 6
<b>Recommended torque</b>	0.6-0.8 Nm	1.5-1.8 Nm

Please visit [www.schaffner.com](http://www.schaffner.com) to find more details on filter connectors.



## Headquarters, global innovation and development center

### Switzerland

#### Schaffner Group

Nordstrasse 11  
4542 Luterbach  
T +41 32 6816 626  
F +41 32 6816 630  
[info@schaffner.com](mailto:info@schaffner.com)  
<http://www.schaffner.com>



## Sales and application centers

### China

#### Schaffner EMC Ltd. Shanghai

T20-3, No 565 Chuangye Road  
Pudong New Area  
201201 Shanghai  
T +86 21 3813 9500  
F +86 21 3813 9501 / 02  
[cschina@schaffner.com](mailto:cschina@schaffner.com)  
<http://www.schaffner.com.cn/>

### Finland

#### Schaffner Oy

Sauvonrinne 19 H  
08500 Lohja  
T +358 19 35 72 71  
[finlandsales@schaffner.com](mailto:finlandsales@schaffner.com)

### France

#### Schaffner EMC S.A.S.

112, Quai de Bezons  
Boîte postale 133  
95103 Argenteuil  
T +33 1 34 34 30 60  
F +33 1 39 47 02 28  
[francesales@schaffner.com](mailto:francesales@schaffner.com)

### Germany

#### Schaffner Deutschland GmbH

Schoemperlenstrasse 12B  
76185 Karlsruhe  
T +49 721 56910  
F +49 721 569110  
[germanysales@schaffner.com](mailto:germanysales@schaffner.com)

### Italy

#### Schaffner EMC S.r.l.

Via Galileo Galilei 47  
20092 Cinisello Balsamo (MI)  
T +39 02 66 04 30 45/47  
F +39 02 61 23 943  
[italysales@schaffner.com](mailto:italysales@schaffner.com)

### Japan

#### Schaffner EMC K.K.

1-32-12, Kamiyama, Setagaya-ku  
7F Mitsui-seimei Sangenjaya Bldg.  
154-0011 Tokyo  
T +81 3 5712 3650  
F +81 3 5712 3651  
[japansales@schaffner.com](mailto:japansales@schaffner.com)  
<http://www.schaffner.jp>

### Singapore

#### Schaffner EMC Pte Ltd.

Blk 3015A Ubi Road 1  
05-09 Kampong Ubi Industrial Estate  
408705 Singapore  
T +65 6377 3283  
F +65 6377 3281  
[singaporesales@schaffner.com](mailto:singaporesales@schaffner.com)

### Spain

#### Schaffner EMC España

Calle Caléndula 93  
Miniparc III, Edificio E  
El Soto de la Moraleja  
Alcobendas  
28109 Madrid  
T +34 618 176 133  
[spainsales@schaffner.com](mailto:spainsales@schaffner.com)

### Sweden

#### Schaffner EMC AB

Turebergstorg 1, 6  
19147 Sollentuna  
T +46 8 5792 1121 / 22  
F +46 8 92 96 90  
[swedensales@schaffner.com](mailto:swedensales@schaffner.com)

### Switzerland

#### Schaffner EMV AG

Nordstrasse 11  
4542 Luterbach  
T +41 32 6816 626  
F +41 32 6816 641  
[sales@schaffner.ch](mailto:sales@schaffner.ch)

### Taiwan R.O.C.

#### Schaffner EMV Ltd.

6 Floor, No. 413  
Rui Guang Road  
114 Neihu District Taipei City  
T +886 2 87525050  
F +886 2 87518086  
[taiwansales@schaffner.com](mailto:taiwansales@schaffner.com)

### Thailand

#### Schaffner EMC Co. Ltd.

Northern Region Industrial Estate  
67 Moo 4 Tambon Ban Klang  
Amphur Muang P.O. Box 14  
51000 Lamphun  
T +66 53 58 11 04  
F +66 53 58 10 19  
[thailandsales@schaffner.com](mailto:thailandsales@schaffner.com)

### UK

#### Schaffner Ltd.

5 Ashville Way  
Molly Millars Lane  
Wokingham  
RG41 2PL Berkshire  
T +44 118 9770070  
F +44 118 9792969  
[uksales@schaffner.com](mailto:uksales@schaffner.com)  
<http://www.schaffner.uk.com>

### USA

#### Schaffner EMC Inc.

52 Mayfield Avenue  
08837 Edison, New Jersey  
T +1 800 367 5566  
T +1 732 225 9533  
F +1 732 225 4789  
[usasales@schaffner.com](mailto:usasales@schaffner.com)  
<http://www.schaffner.com/us>

#### Schaffner MTC LLC

6722 Thirlane Road  
24019 Roanoke, Virginia  
T +1 276 228 7943  
F +1 276 228 7953  
<http://www.schaffner-mtc.com>

#### Schaffner Trencos LLC

2550 Brookpark Road  
44134 Cleveland, Ohio  
T +1 216 741 5282  
F +1 216 741 4860  
[www.schaffner-trencos.com](http://www.schaffner-trencos.com)

To find your local partner within Schaffner's global network: [www.schaffner.com](http://www.schaffner.com)

© 2014 Schaffner Group

The content of this document has been carefully checked and understood. However, neither Schaffner nor its subsidiaries assume any liability whatsoever for any errors or inaccuracies of this document and the consequences thereof. Published specifications are subject to change without notice. Product suitability for any area of application must ultimately be determined by the customer. In all cases, products must never be operated outside their published specifications. Schaffner does not guarantee the availability of all published products. This disclaimer shall be governed by substantive Swiss law and resulting disputes shall be settled by the courts at the place of business of Schaffner Holding AG. Latest publications and a complete disclaimer can be downloaded from the Schaffner website. All trademarks recognized.



Компания «ЭлектроПласт» предлагает заключение долгосрочных отношений при поставках импортных электронных компонентов на взаимовыгодных условиях!

Наши преимущества:

- Оперативные поставки широкого спектра электронных компонентов отечественного и импортного производства напрямую от производителей и с крупнейших мировых складов;
- Поставка более 17-ти миллионов наименований электронных компонентов;
- Поставка сложных, дефицитных, либо снятых с производства позиций;
- Оперативные сроки поставки под заказ (от 5 рабочих дней);
- Экспресс доставка в любую точку России;
- Техническая поддержка проекта, помощь в подборе аналогов, поставка прототипов;
- Система менеджмента качества сертифицирована по Международному стандарту ISO 9001;
- Лицензия ФСБ на осуществление работ с использованием сведений, составляющих государственную тайну;
- Поставка специализированных компонентов (Xilinx, Altera, Analog Devices, Intersil, Interpoint, Microsemi, Aeroflex, Peregrine, Syfer, Eurofarad, Texas Instrument, Miteq, Cobham, E2V, MA-COM, Hittite, Mini-Circuits, General Dynamics и др.);

Помимо этого, одним из направлений компании «ЭлектроПласт» является направление «Источники питания». Мы предлагаем Вам помощь Конструкторского отдела:

- Подбор оптимального решения, техническое обоснование при выборе компонента;
- Подбор аналогов;
- Консультации по применению компонента;
- Поставка образцов и прототипов;
- Техническая поддержка проекта;
- Защита от снятия компонента с производства.



#### Как с нами связаться

**Телефон:** 8 (812) 309 58 32 (многоканальный)

**Факс:** 8 (812) 320-02-42

**Электронная почта:** [org@eplast1.ru](mailto:org@eplast1.ru)

**Адрес:** 198099, г. Санкт-Петербург, ул. Калинина, дом 2, корпус 4, литера А.