

Data Sheet

AS01508MS-SP11-WP-R

PUI Audio’s **Mobile Series** line of speakers and receivers is designed for cutting-edge applications such as smart watches and pendants, Wi-Fi enabled security devices and action cameras, mobile radios and smart phones, as well as IoT devices. Each **Mobile Series** product features an IP67-rated face for protection against dust and water ingress.

The eight ohm 15mm x 11mm **AS01508MS-SP11-WP-R** speaker is designed for high fidelity audio reproduction in the thinnest size possible—only 3.5mm thick! Solder pads allow for lead wire attachment.

Features:

- PEEK diaphragm for flat frequency response
- 89 dB output (2V @ 10cm)
- High-energy neodymium motor
- Only 3.5 mm thick
- Dustproof and waterproof IP67-rated face

Specifications

Parameters	Values	Units
Rated Input Power	0.7	Watts
Max Input Power	1	Watts
Impedance	8 ± 15%	Ohms
Sensitivity (SPL @ 2V/10cm) Average 0.8, 1.0, 1.5, 2.0 kHz	89 ± 3	dB
Resonant Frequency (free air)	600 ± 20%	Hz
Frequency Range	600 ~ 20,000	Hz
Frame Material	PBT	-
Magnet Material	NdFeB	-
Weight	1.5	Grams
Environmental Protection Rating	IP67	-

Specifications (continued)

Buzz, Rattle, etc.	Should not be audible with 2.37V sine wave from 300 Hz to 3.4 kHz	-
Polarity	When positive voltage is applied to the positive terminal, the diaphragm will move outward	-
Storage Temperature	-40 ~ +80	°C
Operating Temperature	-20 ~ +70	°C

Measurement Method (measured with 2V, Temperature: 15 ~ 35°C, Relative Humidity: 25%~70%)

Standard test condition of speaker

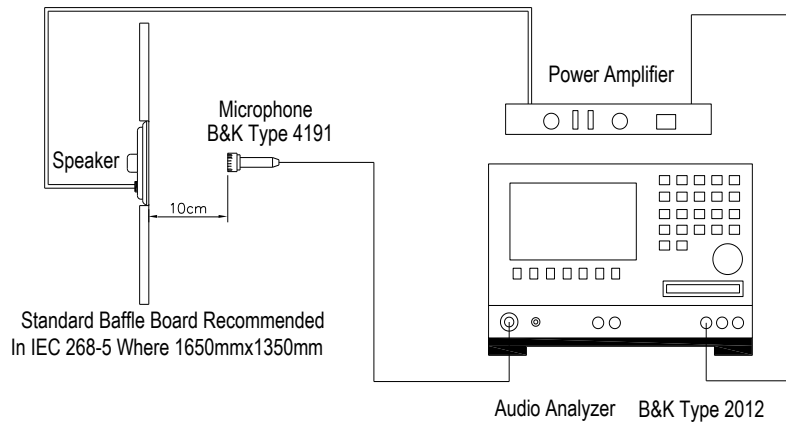

Frequency Response (measured with 2V @ 10cm in 10cc enclosure)

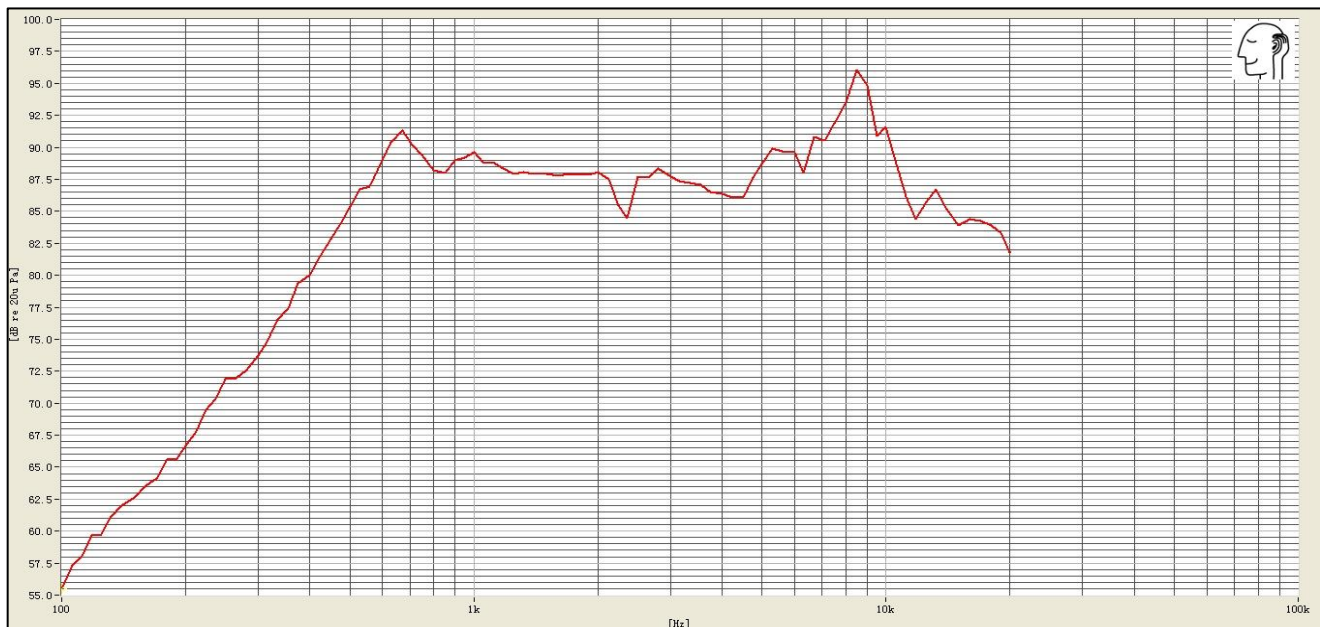

Impedance Response (Measured with speaker in a 10cc enclosure)

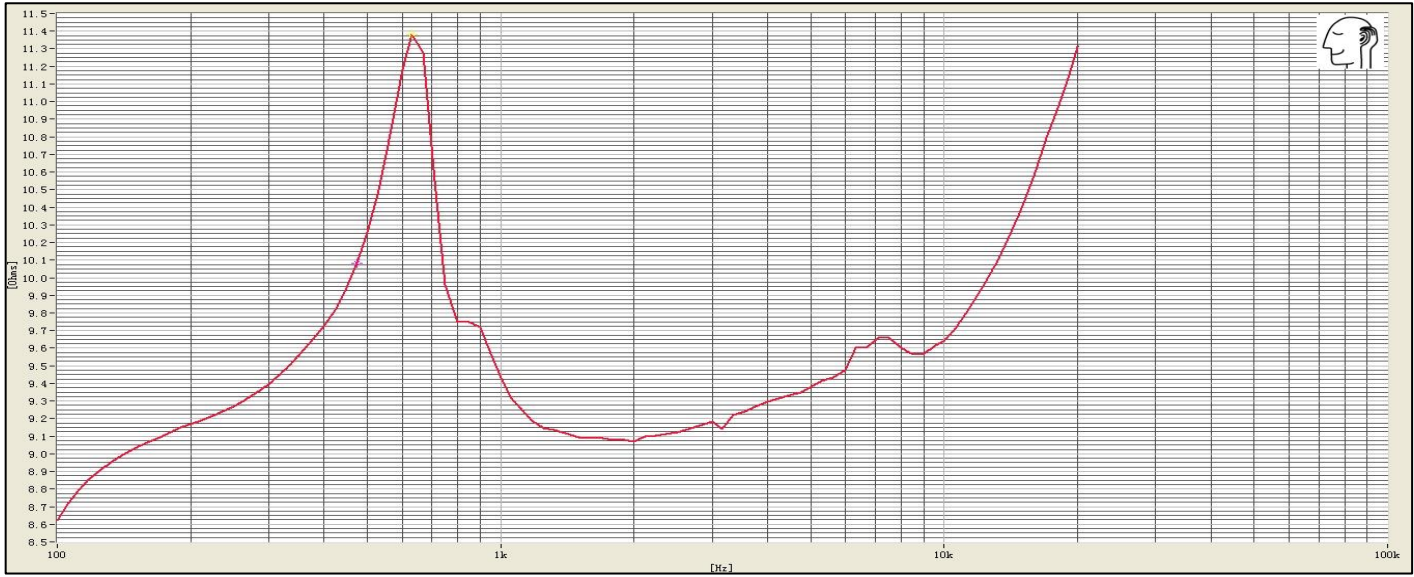

Reliability Testing

Type of Test	Test Specifications
High Temperature Test	96 hours at +80°C ± 3°C followed by three hours in normal room temperature
Low Temperature Test	96 hours at -40°C ± 3°C followed by three hours in normal room temperature
Humidity Test	96 hours at +40°C ± 3°C with relative humidity at 90%~95% followed by 6 hours in normal room temperature
Temperature Cycle Testing	The part shall be subjected to 12 cycles using the following procedure: Low temperature: -40°C±3°C High temperature: +80°C±3°C Cycle: 2 hours at High, 5 minutes High to Low, 2 hours at Low, 5 minutes Low to High
Vibration Test	10 to 55 to 10 Hz sine sweep, per minute @ 1.5mm amplitude 2 hours in each axis X, Y, and Z
Drop Test	Mount speaker to 100g fixture, drop fixture 1.5 meters, twice per side and twice for each corner
Load Test	White noise is applied at the speakers rated power for 96 hours at room temperature with speaker in 1cc enclosure

After each test, the speaker's SPL shall be ±3 dB of the original SPL

Dimensions (Right contact is positive on the far right drawing below)

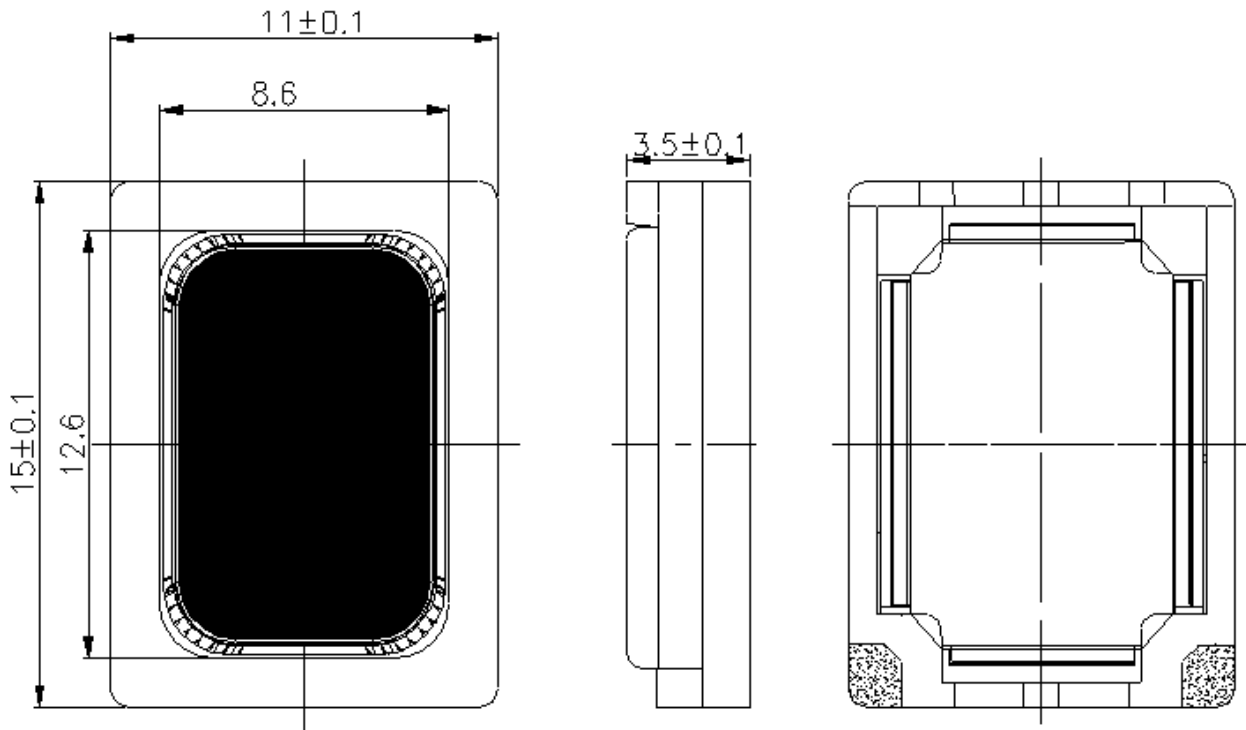

Packaging

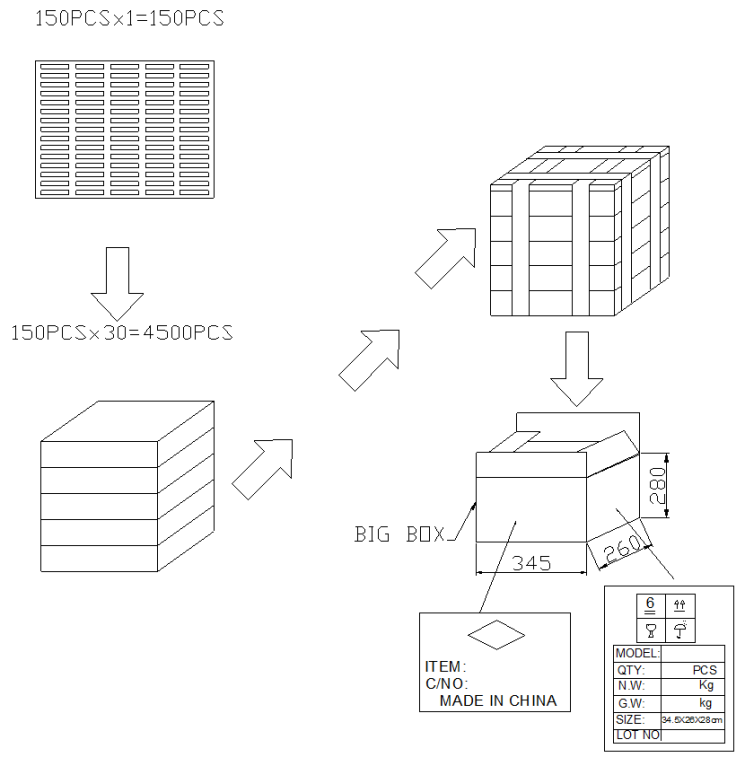

Specifications Revisions

Revision	Description	Date
-	Released from Engineering	11/20/2017

Note:

1. Unless otherwise specified:
 - A. All dimensions are in millimeters.
 - B. Default tolerances are $\pm 0.5\text{mm}$ and angles are $\pm 3^\circ$.
2. Specifications subject to change or withdrawal without notice.
3. This part is RoHS 2011/65/EU Compliant.



Компания «ЭлектроПласт» предлагает заключение долгосрочных отношений при поставках импортных электронных компонентов на взаимовыгодных условиях!

Наши преимущества:

- Оперативные поставки широкого спектра электронных компонентов отечественного и импортного производства напрямую от производителей и с крупнейших мировых складов;
- Поставка более 17-ти миллионов наименований электронных компонентов;
- Поставка сложных, дефицитных, либо снятых с производства позиций;
- Оперативные сроки поставки под заказ (от 5 рабочих дней);
- Экспресс доставка в любую точку России;
- Техническая поддержка проекта, помощь в подборе аналогов, поставка прототипов;
- Система менеджмента качества сертифицирована по Международному стандарту ISO 9001;
- Лицензия ФСБ на осуществление работ с использованием сведений, составляющих государственную тайну;
- Поставка специализированных компонентов (Xilinx, Altera, Analog Devices, Intersil, Interpoint, Microsemi, Aeroflex, Peregrine, Syfer, Eurofarad, Texas Instrument, Miteq, Cobham, E2V, MA-COM, Hittite, Mini-Circuits, General Dynamics и др.);

Помимо этого, одним из направлений компании «ЭлектроПласт» является направление «Источники питания». Мы предлагаем Вам помощь Конструкторского отдела:

- Подбор оптимального решения, техническое обоснование при выборе компонента;
- Подбор аналогов;
- Консультации по применению компонента;
- Поставка образцов и прототипов;
- Техническая поддержка проекта;
- Защита от снятия компонента с производства.



Как с нами связаться

Телефон: 8 (812) 309 58 32 (многоканальный)

Факс: 8 (812) 320-02-42

Электронная почта: org@eplast1.ru

Адрес: 198099, г. Санкт-Петербург, ул. Калинина, дом 2, корпус 4, литера А.