

# FP1 107R

## High frequency, high current power inductors



### Product features

- High current carrying capacity
- Low core loss, magnetically shielded
- Tight tolerance DCR for sensing circuits
- Magnetically shielded
- Inductance range from 70 nH to 510 nH
- Current range from 42 A to 140 A
- Frequency range up to 2 MHz
- 11 mm x 7.2 mm and 11.2 mm x 8.0 mm footprint surface mount package in 6.5 mm, 7.2 and 7.5 mm heights
- Ferrite core material
- Moisture sensitivity level (MSL): 1

### Applications

- Multi-phase and Vcore regulators
- Voltage Regulator Modules (VRMs)
  - Server and desktop
  - Central processing unit (CPU)
  - Graphics processing unit (GPU)
  - Application specific integrated circuit (ASIC)
  - High power density
- Data networking and storage systems
- Graphics cards and battery power systems
- Point-of-load modules
- DCR Sensing circuits

### Environmental compliance and general specifications

- Storage temperature range (Component): -40 °C to +125 °C
- Operating temperature range: -40 °C to +125 °C (ambient plus self-temperature rise)
- Solder reflow temperature: J-STD-020 (latest revision) compliant



Product Specifications

Part number <sup>9</sup>	OCL <sup>1</sup> (nH) ±10%	FLL <sup>2</sup> (nH) minimum	I <sub>rms</sub> <sup>3</sup> (A)	I <sub>sat</sub> 1 <sup>4</sup> (A)	I <sub>sat</sub> 2 <sup>5</sup> (A)	I <sub>sat</sub> 3 <sup>6</sup> (A)	I <sub>sat</sub> 4 <sup>7</sup> (A)	DCR (mΩ) @ +20°C	K-factor <sup>8</sup>
<b>R1 version</b>									
FP1107R1-R07-R	70	50	55	140	na	na	123	0.29 ±8%	361.1
FP1107R1-R12-R	120	86	55	90	na	na	72	0.29 ±8%	361.1
FP1107R1-R15-R	150	108	55	70	na	na	56	0.29 ±8%	361.1
FP1107R1-R23-R	230	166	55	45	na	na	36	0.29 ±8%	361.1
FP1107R1-R30-R	300	217	55	35	na	na	28	0.29 ±8%	361.1
FP1107R1-R40-R	400	288	55	25	na	na	20	0.29 ±8%	361.1
FP1107R1-R51-R	510	364	55	18	na	na	14.5	0.29 ±8%	361.1
<b>R2 version</b>									
FP1107R2-R07-R	70	50	42	140	na	na	123	0.47 ±6.4%	363.3
FP1107R2-R12-R	120	86	42	90	na	na	72	0.47 ±6.4%	363.3
FP1107R2-R15-R	150	108	42	70	na	na	56	0.47 ±6.4%	363.3
FP1107R2-R23-R	230	166	42	45	na	na	36	0.47 ±6.4%	363.3
FP1107R2-R30-R	300	217	42	35	na	na	28	0.47 ±6.4%	363.3
FP1107R2-R40-R	400	288	42	25	na	na	20	0.47 ±6.4%	363.3
FP1107R2-R51-R	510	364	42	18	na	na	14.5	0.47 ±6.4%	363.3
<b>R4 version</b>									
FP1107R4-R180-R	180	130	50	62	55	53	50	0.29 ±5%	361
<b>R5 version</b>									
FP1107R5-R070-R	70	50	55	140	na	na	123	0.29 ±5%	361.1
FP1107R5-R120-R	120	86	55	90	na	na	72	0.29 ±5%	361.1
FP1107R5-R150-R	150	108	55	70	na	na	56	0.29 ±5%	361.1
FP1107R5-R230-R	230	166	55	45	na	na	36	0.29 ±5%	361.1
FP1107R5-R300-R	300	217	55	35	na	na	28	0.29 ±5%	361.1
FP1107R5-R400-R	400	288	55	25	na	na	20	0.29 ±5%	361.1
FP1107R5-R510-R	510	364	55	18	na	na	14.5	0.29 ±5%	361.1

1. Open circuit inductance (OCL) Test parameters: 100 kHz, 0.1 Vrms, 0.0 Adc, +25 °C

2. Full load inductance (FLL) Test parameters: 100 kHz, 0.1 Vrms, Isat1, +25 °C

3. I<sub>rms</sub>: DC current for an approximate temperature rise of 40 °C without core loss. Derating is necessary for AC currents. PCB layout, trace thickness and width, air-flow, and proximity of other heat generating components will affect the temperature rise. It is recommended that the temperature of the part not exceed +125 °C under worst case operating conditions verified in the end application.

4. I<sub>sat</sub>1: Peak current for approximately 20% rolloff @ +25 °C

5. I<sub>sat</sub>2: Peak current for approximately 20% rolloff @ +85 °C

6. I<sub>sat</sub>3: Peak current for approximately 20% rolloff @ +100 °C

7. I<sub>sat</sub>4: Peak current for approximately 20% rolloff @ +125 °C

8. K-factor: Used to determine Bp-p for core loss (see graph). Bp-p = K \* L \* ΔI \* 10<sup>3</sup>. Bp-p:(Gauss), K: (K-factor from table), L: (Inductance in nH), Symbol I (Peak to peak ripple current in Amps).

9. Part Number Definition: FP1107Rx-Rxxx-R

FP1107R= Product code and size

x= Version indicator

-Rxxx= Inductance value in μH, R= decimal point

-R suffix = RoHS compliant

**Dimensions (mm)**

**FP1107R1, R2, R5**

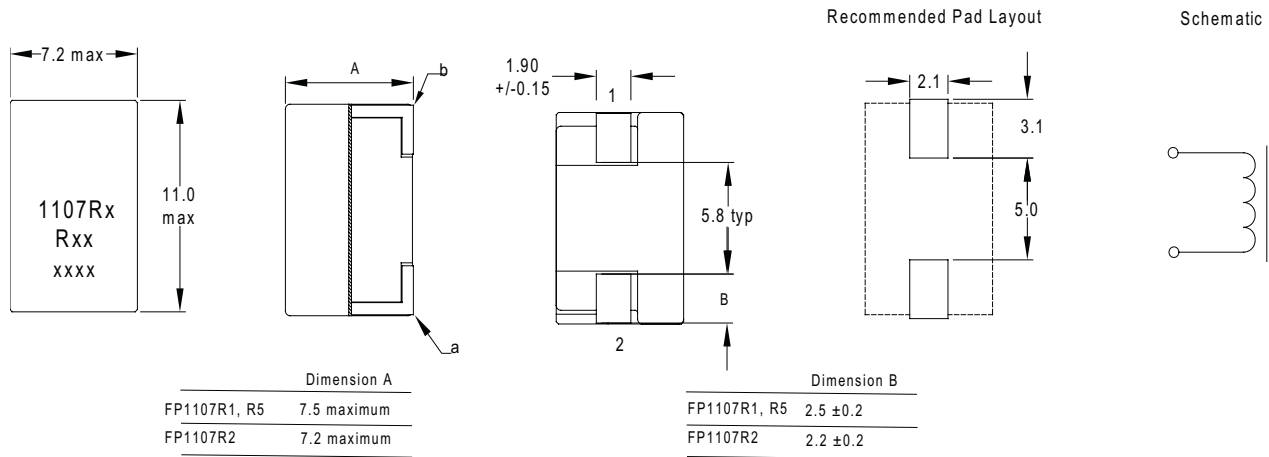

Part marking: 1107Rx (x = Version indicator), Rxxx = Inductance value in uH (R= decimal point)  
xxxx= lot code  
Tolerances are ±0.15 millimeters unless stated otherwise  
All soldering surfaces to be coplanar within 0.1016 millimeters  
Pad layout tolerances are ±0.1 millimeters unless stated otherwise  
DCR measured from point "a" to point "b"  
Traces or vias underneath the inductor is not recommended

**FP1107R4**

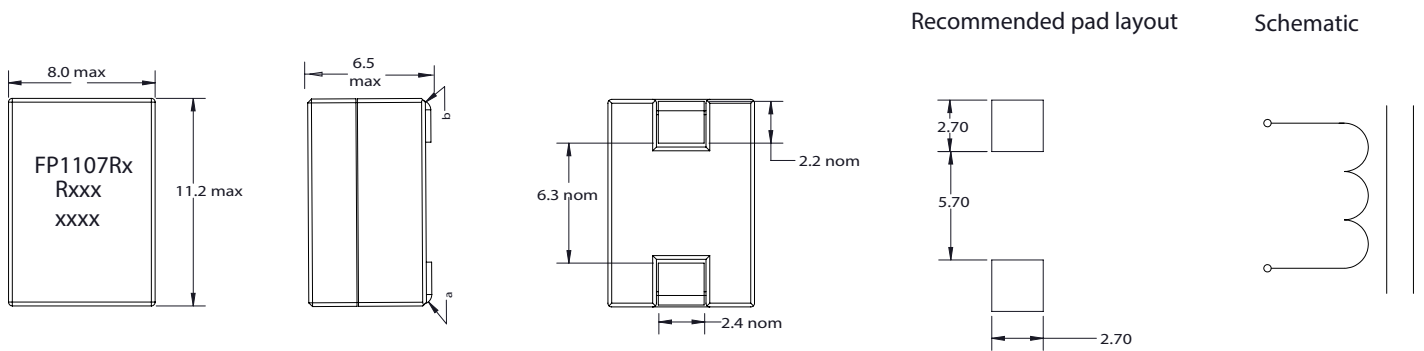

Part marking: FP1107Rx (x = Version indicator), Rxxx = Inductance value in uH (R= decimal point)  
xxxx= lot code  
Tolerances are ±0.15 millimeters unless stated otherwise  
All soldering surfaces to be coplanar within 0.1 millimeters  
Pad layout tolerances are ±0.1 millimeters unless stated otherwise  
DCR measured from point "a" to point "b"  
Traces or vias underneath the inductor is not recommended

**Packaging information (mm)**

**FP1107R1, R2** Supplied in tape and reel packaging , 640 parts per 13" diameter reel  
**FP1107R5** Supplied in tape and reel packaging , 600 parts per 13" diameter reel

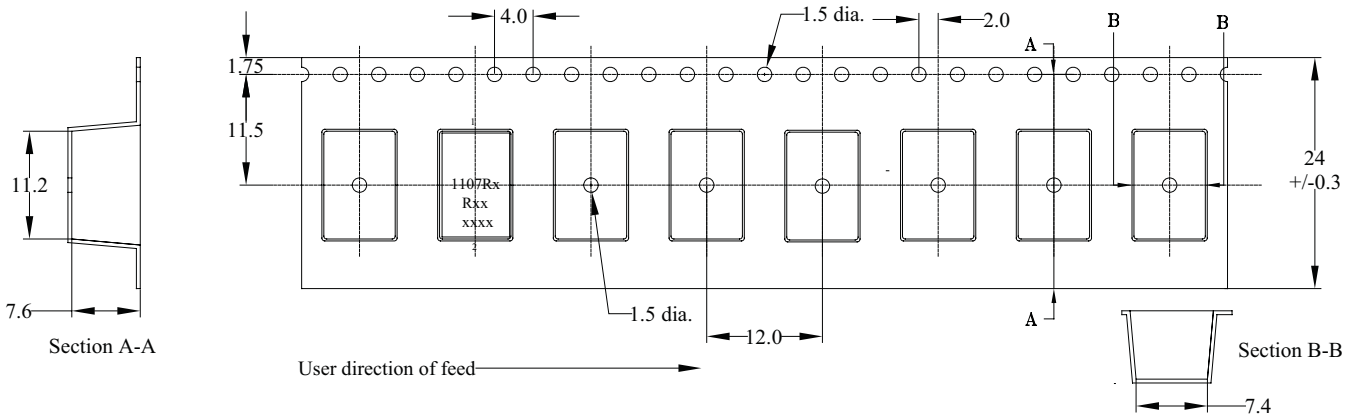

**Packaging information (mm)**

**FP1107R4** Supplied in tape and reel packaging , 750 parts per 13" diameter reel

<b>W±0.3</b>	<b>24.00</b>
<b>F±0.1</b>	<b>11.50</b>
<b>E1 ±0.1</b>	<b>1.75</b>
<b>P0±0.1</b>	<b>4.00</b>
<b>P1±0.1</b>	<b>12.00</b>
<b>P2±0.1</b>	<b>2.00</b>
<b>D0 <sup>0.1</sup>/<sub>0.0</sub></b>	<b>1.50</b>
<b>D1 <sup>0.1</sup>/<sub>0.0</sub></b>	<b>1.50</b>
<b>A0±0.1</b>	<b>8.3</b>
<b>A1±0.1</b>	
<b>B0±0.1</b>	<b>11.5</b>
<b>B1±0.1</b>	
<b>K0±0.1</b>	<b>6.7</b>
<b>T±0.05</b>	<b>0.4</b>

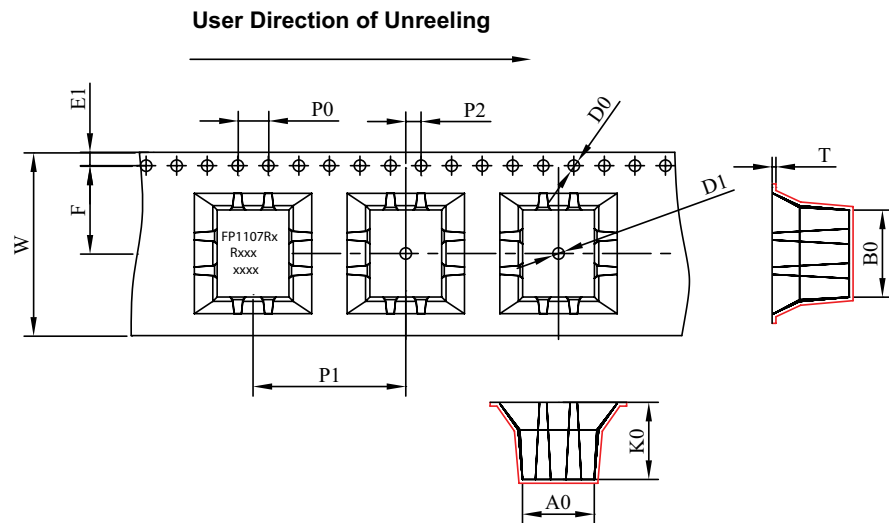

Temperature rise vs. total loss

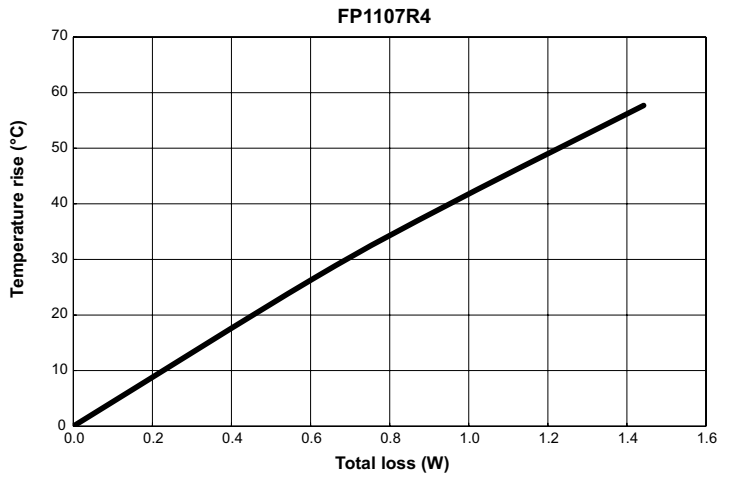
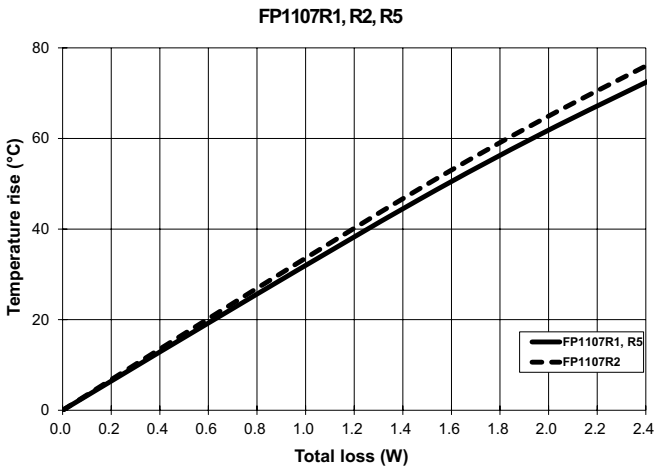

Core loss vs.  $B_{p-p}$

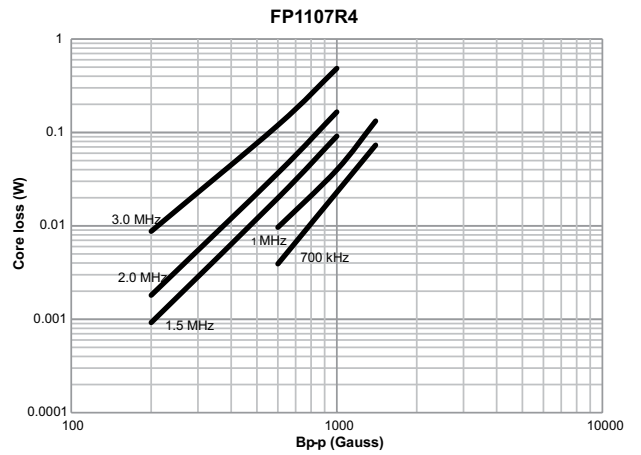
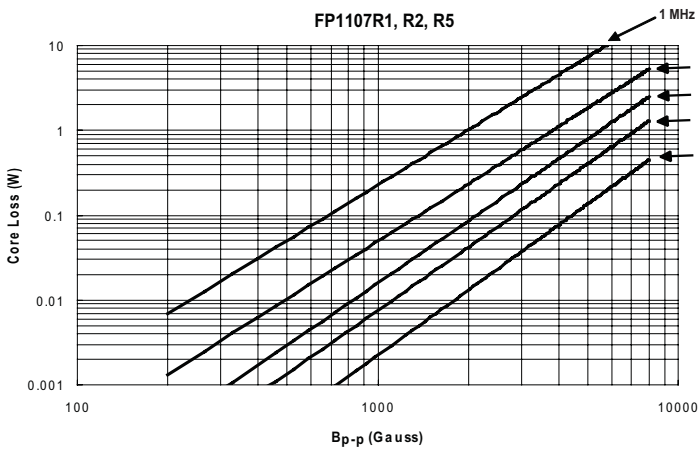

Inductance characteristics

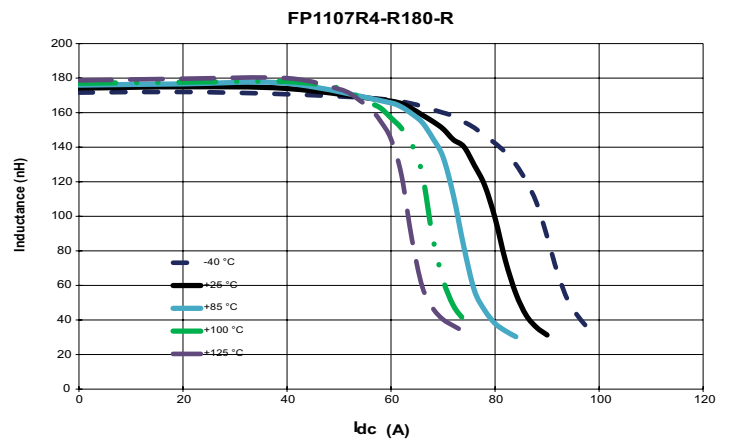
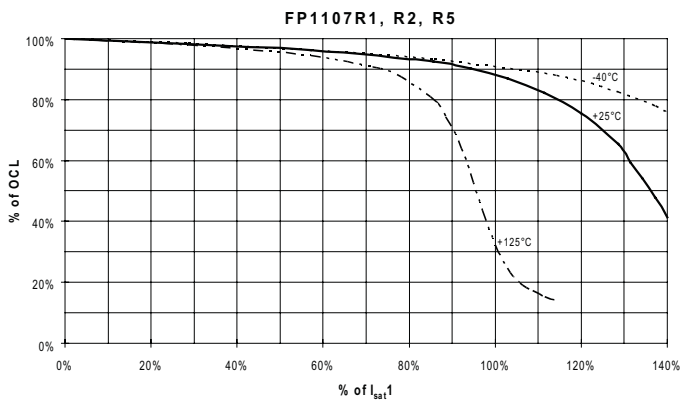

**Solder reflow profile**

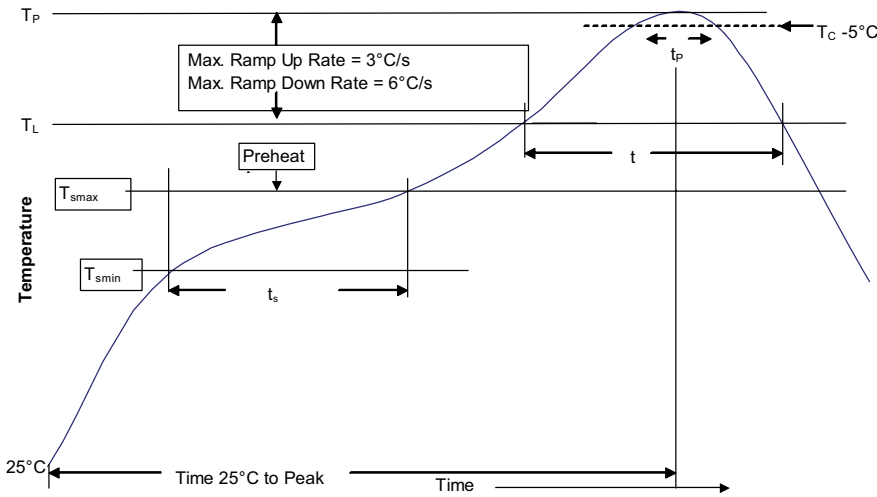

**Table 1 - Standard SnPb solder (T<sub>C</sub>)**

Package thickness	Volume mm <sup>3</sup> <350	Volume mm <sup>3</sup> ≥350
<2.5 mm	235 °C	220 °C
≥2.5 mm	220 °C	220 °C

**Table 2 - Lead (Pb) free solder (T<sub>C</sub>)**

Package thickness	Volume mm <sup>3</sup> <350	Volume mm <sup>3</sup> 350 - 2000	Volume mm <sup>3</sup> >2000
<1.6 mm	260 °C	260 °C	260 °C
1.6 – 2.5 mm	260 °C	250 °C	245 °C
>2.5 mm	250 °C	245 °C	245 °C

**Reference J-STD-020**

Profile feature	Standard SnPb solder	Lead (Pb) free solder
Preheat and soak		
• Temperature min. (T <sub>smin</sub> )	100 °C	150 °C
• Temperature max. (T <sub>smax</sub> )	150 °C	200 °C
• Time (T <sub>smin</sub> to T <sub>smax</sub> ) (t <sub>s</sub> )	60-120 seconds	60-120 seconds
Ramp up rate T <sub>L</sub> to T <sub>p</sub>	3 °C/ second max.	3 °C/ second max.
Liquidous temperature (T <sub>L</sub> )	183 °C	217 °C
Time (t <sub>L</sub> ) maintained above T <sub>L</sub>	60-150 seconds	60-150 seconds
Peak package body temperature (T <sub>p</sub> )*	Table 1	Table 2
Time (t <sub>p</sub> )* within 5 °C of the specified classification temperature (T <sub>C</sub> )	20 seconds*	30 seconds*
Ramp-down rate (T <sub>p</sub> to T <sub>L</sub> )	6 °C/ second max.	6 °C/ second max.
Time 25 °C to peak temperature	6 minutes max.	8 minutes max.

\* Tolerance for peak profile temperature (T<sub>p</sub>) is defined as a supplier minimum and a user maximum.

Life Support Policy: Eaton does not authorize the use of any of its products for use in life support devices or systems without the express written approval of an officer of the Company. Life support systems are devices which support or sustain life, and whose failure to perform, when properly used in accordance with instructions for use provided in the labeling, can be reasonably expected to result in significant injury to the user.

Eaton reserves the right, without notice, to change design or construction of any products and to discontinue or limit distribution of any products. Eaton also reserves the right to change or update, without notice, any technical information contained in this bulletin.

**Eaton**  
Electronics Division  
1000 Eaton Boulevard  
Cleveland, OH 44122  
United States  
Eaton.com/electronics

© 2020 Eaton  
All Rights Reserved  
Printed in USA  
Publication No. 4342  
June 2020

Eaton is a registered trademark.

All other trademarks are property of their respective owners.

Follow us on social media to get the latest product and support information.





Компания «ЭлектроПласт» предлагает заключение долгосрочных отношений при поставках импортных электронных компонентов на взаимовыгодных условиях!

Наши преимущества:

- Оперативные поставки широкого спектра электронных компонентов отечественного и импортного производства напрямую от производителей и с крупнейших мировых складов;
- Поставка более 17-ти миллионов наименований электронных компонентов;
- Поставка сложных, дефицитных, либо снятых с производства позиций;
- Оперативные сроки поставки под заказ (от 5 рабочих дней);
- Экспресс доставка в любую точку России;
- Техническая поддержка проекта, помощь в подборе аналогов, поставка прототипов;
- Система менеджмента качества сертифицирована по Международному стандарту ISO 9001;
- Лицензия ФСБ на осуществление работ с использованием сведений, составляющих государственную тайну;
- Поставка специализированных компонентов (Xilinx, Altera, Analog Devices, Intersil, Interpoint, Microsemi, Aeroflex, Peregrine, Syfer, Eurofarad, Texas Instrument, Miteq, Cobham, E2V, MA-COM, Hittite, Mini-Circuits, General Dynamics и др.);

Помимо этого, одним из направлений компании «ЭлектроПласт» является направление «Источники питания». Мы предлагаем Вам помощь Конструкторского отдела:

- Подбор оптимального решения, техническое обоснование при выборе компонента;
- Подбор аналогов;
- Консультации по применению компонента;
- Поставка образцов и прототипов;
- Техническая поддержка проекта;
- Защита от снятия компонента с производства.



#### Как с нами связаться

**Телефон:** 8 (812) 309 58 32 (многоканальный)

**Факс:** 8 (812) 320-02-42

**Электронная почта:** [org@eplast1.ru](mailto:org@eplast1.ru)

**Адрес:** 198099, г. Санкт-Петербург, ул. Калинина, дом 2, корпус 4, литера А.