

Mini-Com® Stainless Steel Faceplates

PANDUIT®

SPECIFICATION SHEET

specifications

Stainless steel faceplates with labels shall be available in 2, 4, and 6-port single gang and various double gang configurations. Each faceplate shall accept copper, fiber, and AV modules that snap in and out without the use of tools. Faceplates shall have flush profile, and optional built in label pocket for easy identification. Stainless steel material shall be attached to a high impact ABS backing to provide a durable faceplate with brushed stainless steel finish.



technical information

Material:	304 grade stainless steel with satin finish is mounted on ABS backing and is suitable for hospital and laboratory environments; easy to clean
Mounting options:	Screw holes spaced for single and double gang openings; compatible with Panduit wall board adapters
Packaging:	Supplied with two or four 1" long, #6-32 slotted head screws; faceplates packaged one per bag, ten per box; labeled faceplates include label kit

key features and benefits

Durable	Impact resistant material supports installations in high traffic
Modular	Accepts all Mini-Com® Modules which snap in and out for easy moves, adds, and changes
Various port densities	Provides design flexibility
Flush mounting	Provides superior aesthetics
Label version available	Can be clearly identified with optional labels for port identification
Sloped recessed	Allows proper bend radius

applications

Mini-Com® Stainless Steel Faceplates are ideal for use in hospitals, laboratories, schools, and office environments. The faceplates are compatible with most standard single and double gang electrical boxes, wall board

adapters, and raceway mounting brackets. These durable stainless steel faceplates are available with or without labels. Printable labels are available for compliance to the ANSI/TIA-606B labeling standard.

Single Gang Sloped Recessed Faceplates with Labels

2-port:	CFPSL2S
4-port:	CFPSL4S

Single Gang Faceplates with Labels*

2-port:	CFPL2SY
4-port:	CFPL4SY
6-port:	CFPL6SY

Label Options for Single Gang Faceplates

Laser/ink jet:	C195X040Y1J
PanTher™ LS8E:	C196X040Y1C

Double Gang Faceplates with Labels

4-port:	CFPL4S-2GY
6-port:	CFPL6S-2GY
8-port:	CFPL8S-2GY
10-port:	CFPL10S-2GY

Label Options for Double Gang Faceplates

Laser/ink jet:	C288X040Y1J
PanTher™ LS8E:	C288X040Y1C

Single Gang Faceplates without Labels*

2-port:	CFP2SY
4-port:	CFP4SY
6-port:	CFP6SY

Label Options for Single Gang Faceplates

Laser/ink jet	
2 or 4-port:	C061X030FJJ
6-port:	C188X030FJJ
PanTher™ LS8E	
2 or 4-port:	C061X030FJC
6-port:	C188X030FJC

Double Gang Faceplates without Labels

4-port:	CFP4S-2GY
8-port:	CFP8S-2GY
10-port:	CFP10S-2GY

Label Options for Double Gang Faceplates

Laser/ink jet	
4-port:	C061X030FJJ
8-port:	C125X030FJJ
10-port:	C315X030FJJ
PanTher™ LS8E	
4-port:	C061X030FJC
8-port:	C125X030FJC
10-port:	C315X030FJC

Wall Board Adapters

Single gang:	MWBA1
Double gang	MWBA-2G

*Four and six-port, single gang faceplates must be installed on a 1.9" wide (or wider) electrical back box.

Mini-Com® Stainless Steel Faceplates

2, 4, and 6-port single gang faceplate with label

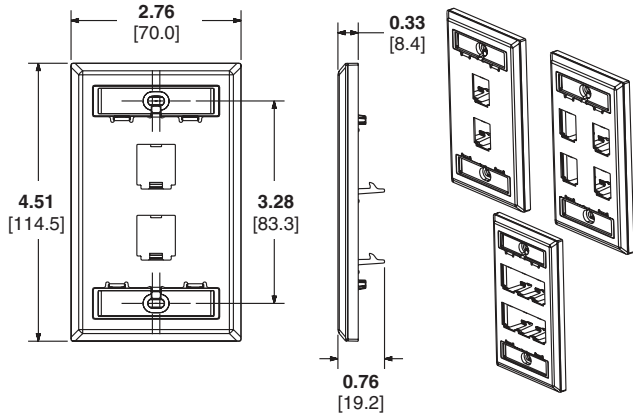

4, 8, and 10-port double gang faceplate with label

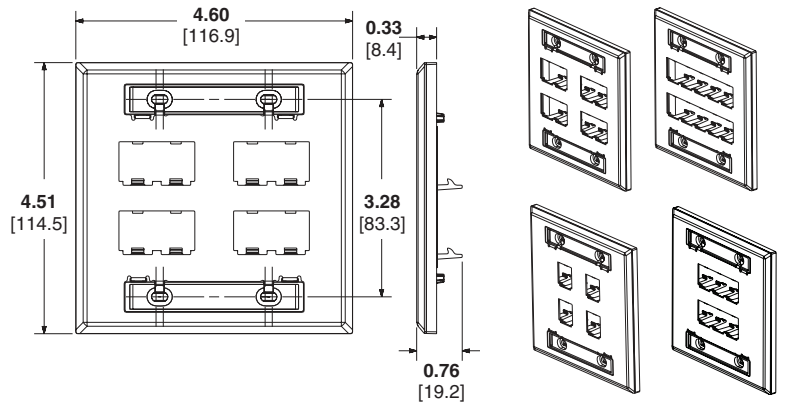

2, 4, and 6-port single gang faceplates

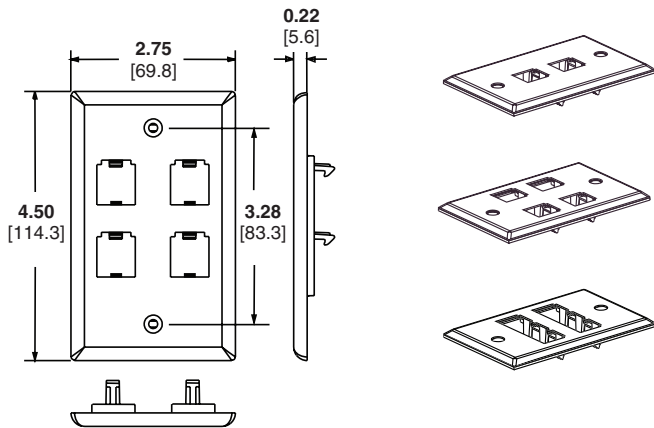

4, 8, and 10-port double gang faceplates

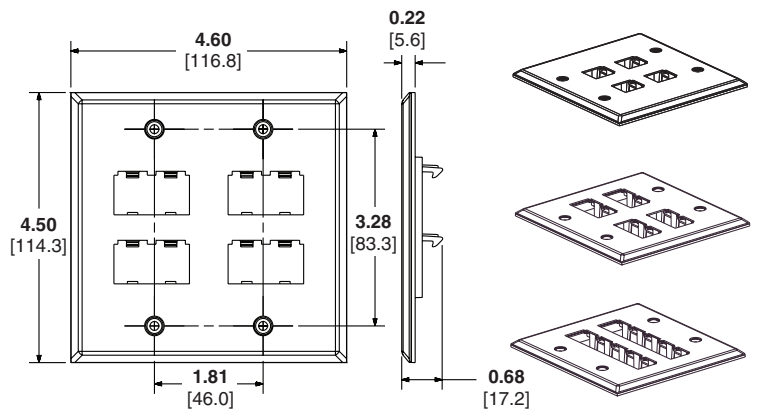

Dimensions are in inches. [Dimensions in brackets are metric.]

Mini-Com® Stainless Steel Faceplates

2-port sloped recessed single gang faceplate with label

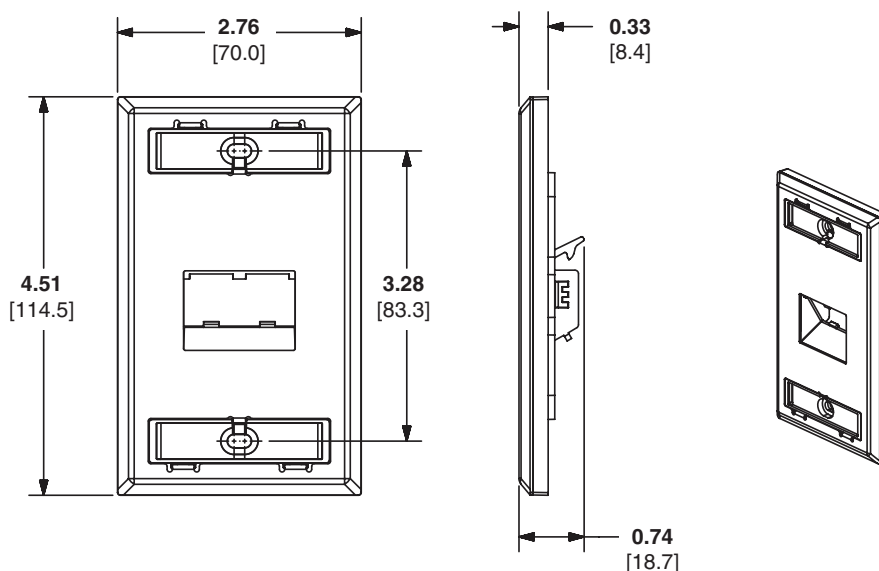

4-port sloped recessed single gang faceplate with label

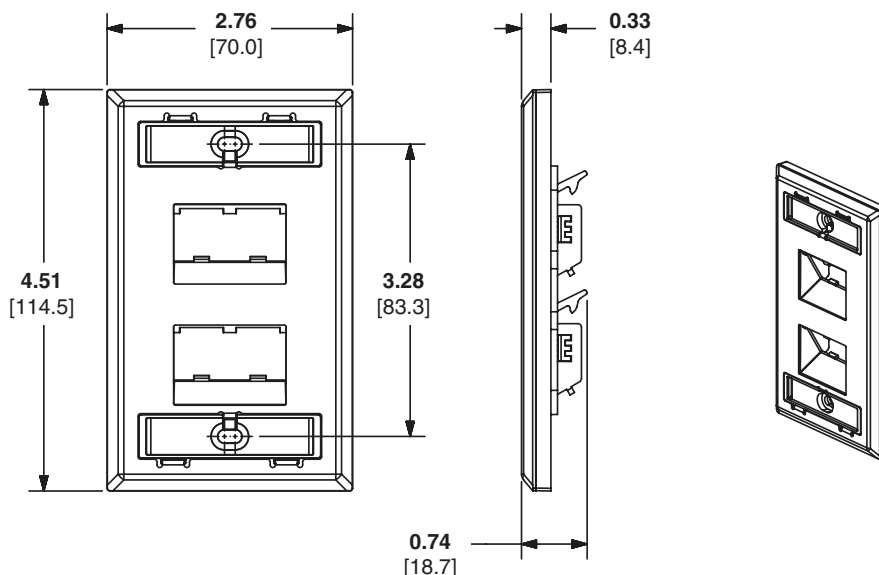

Dimensions are in inches. [Dimensions in brackets are metric.]

WORLDWIDE SUBSIDIARIES AND SALES OFFICES

PANDUIT CANADA
Markham, Ontario
cs-cdn@panduit.com
Phone: 800.777.3300

PANDUIT EUROPE LTD.
London, UK
cs-emea@panduit.com
Phone: 44.20.8601.7200

PANDUIT SINGAPORE PTE. LTD.
Republic of Singapore
cs-ap@panduit.com
Phone: 65.6305.7575

PANDUIT JAPAN
Tokyo, Japan
cs-japan@panduit.com
Phone: 81.3.6863.6000

PANDUIT LATIN AMERICA
Guadalajara, Mexico
cs-la@panduit.com
Phone: 52.33.3777.6000

PANDUIT AUSTRALIA PTY. LTD.
Victoria, Australia
cs-aus@panduit.com
Phone: 61.3.9794.9020

For a copy of Panduit product warranties, log on to www.panduit.com/warranty

For more information

Visit us at www.panduit.com

Contact Customer Service by email: cs@panduit.com
or by phone: 800.777.3300

PANDUIT®

©2014 Panduit Corp.
ALL RIGHTS RESERVED.
OTSP45--WW-ENG
Replaces WW-OTSP16
9/2014



Компания «ЭлектроПласт» предлагает заключение долгосрочных отношений при поставках импортных электронных компонентов на взаимовыгодных условиях!

Наши преимущества:

- Оперативные поставки широкого спектра электронных компонентов отечественного и импортного производства напрямую от производителей и с крупнейших мировых складов;
- Поставка более 17-ти миллионов наименований электронных компонентов;
- Поставка сложных, дефицитных, либо снятых с производства позиций;
- Оперативные сроки поставки под заказ (от 5 рабочих дней);
- Экспресс доставка в любую точку России;
- Техническая поддержка проекта, помощь в подборе аналогов, поставка прототипов;
- Система менеджмента качества сертифицирована по Международному стандарту ISO 9001;
- Лицензия ФСБ на осуществление работ с использованием сведений, составляющих государственную тайну;
- Поставка специализированных компонентов (Xilinx, Altera, Analog Devices, Intersil, Interpoint, Microsemi, Aeroflex, Peregrine, Syfer, Eurofarad, Texas Instrument, Miteq, Cobham, E2V, MA-COM, Hittite, Mini-Circuits, General Dynamics и др.);

Помимо этого, одним из направлений компании «ЭлектроПласт» является направление «Источники питания». Мы предлагаем Вам помощь Конструкторского отдела:

- Подбор оптимального решения, техническое обоснование при выборе компонента;
- Подбор аналогов;
- Консультации по применению компонента;
- Поставка образцов и прототипов;
- Техническая поддержка проекта;
- Защита от снятия компонента с производства.



Как с нами связаться

Телефон: 8 (812) 309 58 32 (многоканальный)

Факс: 8 (812) 320-02-42

Электронная почта: org@eplast1.ru

Адрес: 198099, г. Санкт-Петербург, ул. Калинина, дом 2, корпус 4, литера А.