

Specification

LC/UPC Receptacle XFP

Optical Transceiver Module

10 Gigabit Ethernet
10GBASE-ZR



Ordering Information

T A S - X x U L 5 - Q A 6



Operating Case Temperature

Model Name	Voltage	Category	Device type	Interface	Temperature	Distance
TAS-X1UL5-QA6	3.3V	With DDMI	1550 nm EML	AC-AC / TTL	0°C ~ +70°C	80 km
TAS-X5UL5-QA6					-5°C ~ +70°C	

Features

- **STM64 or 10GBase ZR/ZW application**
- **Supports Data rate 9.95 ~ 11.3 Gbps**
- **Up to 80km transmission distance over SMF**
- **1550nm EML Laser transmitter**
- **1550nm receiver with APD-TIA**
- **2-wire interface for integrated digital diagnostic Monitoring**
- **Operation case temperature 0~70°C and -5~70°C for commercial**
- **Single +3.3V power supply**
- **XFP MAS package with LC/UPC receptacle optical interface**
- **RoHS-10 compliance**

Pin Assignment and Pin Description

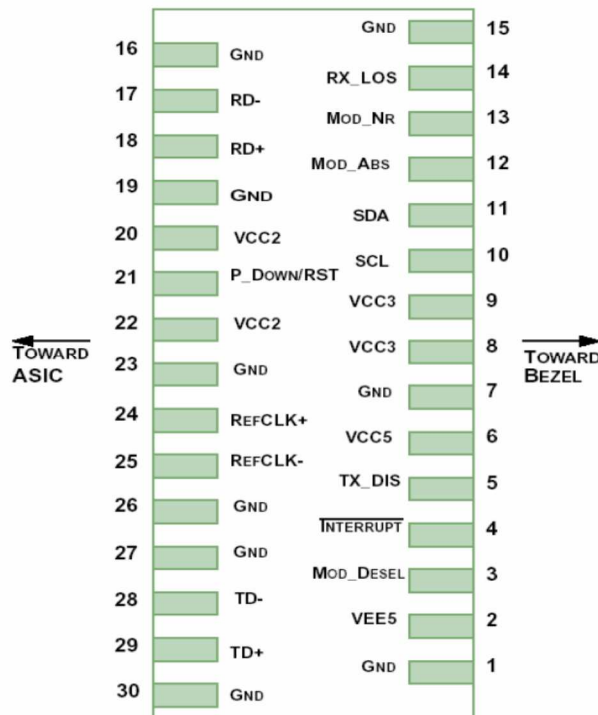

Pin Definitions

PIN	Logic	Symbol	Name/Description	Note
1		GND	Ground	1
2		VEE5	Optional -5.2V power supply, not in use	3
3	LVTLL-I	Mod_DeSel	Module Deselect; when held low allows module to respond 2-wire serial interface	
4	LVTLL-O	Interrupt	Indicates presence of an important condition which can be read over the 2-wire serial interface	2
5	LVTLL-I	TX_DIS	Transmitter Disable; turn off transmitter laser output	
6		VCC5	+5V power supply, not in use	3
7		GND	Ground	1
8		VCC3	+3.3V power supply	
9		VCC3	+3.3V power supply	
10	LVTTL-I/O	SCL	2-wire serial interface clock	2
11	LVTTL-I/O	SDA	2-wire serial interface data	2
12	LVTTL-O	Mod_Abs	Indicates module is not present. ground in the module	2

13	LVTTL-O	Mod_NR	Module not ready, indicating module operational fault	2
14	LVTTL-O	RX_LOS	Receiver loss of signal indicator	2
15		GND	Ground	1
16		GND	Ground	1
17	CML-O	RD-	Receiver Inverted Data Output	
18	CML-O	RD+	Receiver Non-Inverted Data Output	
19		GND	Ground	1
20		VCC2	+1.8V power supply, not in use	3
21	LVTTL-I	P_Down/RST	Power down; when high, requires the module to limit power consumption to 1.5w or below ,2-wire serial interface must be functional in the low power mode	
			Reset; the falling edge initiates a complete reset of the module including the 2-wire Serial interface, equivalent to a power cycle	
22		VCC2	+1.8V power supply, not in use	3
23		GND	Ground	1
24	PECL-I	RefCLK+	Reference clock non-inverted input, ac coupled on the host board, not in use	3
25	PECL-I	RefCLK-	Reference clock inverted input, ac coupled on the host board, not in use	3
26		GND	Ground	1
27		GND	Ground	1
28	CML-I	TD-	Transmitter inverted data input	
29	CML-I	TD+	Transmitter non-inverted data input	
30		GND	Ground	1

Notes:

1. Module ground pins GND are isolated from the module case and chassis ground within the module.
2. Shall be pulled up with 4.7K-10Kohms to a voltage between 3.15V and 3.45V on the host board.
3. Not connected internally.

Absolute Maximum Ratings

It has to be noted that the operation in excess of any individual absolute maximum ratings might cause permanent damage to this module.

Parameters	Symbol	Min.	Max.	Unit
Power Supply Voltage	V _{CC}	3.15	3.45	V
Power Dissipation			2.5	W
Storage Temperature	T _c	-40	85	°C
Operating Case Temperature	T _c	0	70	°C
		-5	70	

Optical Characteristics

The following optical characteristics are defined over the Recommended Operating Environment unless otherwise specified.

Parameter	Symbol	Min.	Typ.	Max	Unit	Notes
Operating Reach, SMF				80	Km	
Transmitter						
Center Wavelength	λ_t	1530	1550	1570	nm	
Spectral Width (-20dB)				1	nm	
Side Mode Suppression Ratio (SMSR)		30			dB	
Average Optical Power	P_{avg}	0		4	dBm	
Transmitter and dispersion penalty (max)	TDP			2	dB	3
Optical Return Loss Tolerance		-12			dB	
Average launch power of Off transmitter	P_{off}			-45	dBm	
Extinction Ratio	ER	9			dB	
Transmitter Mask (PRBS2 ³¹ -1@9.95G)		Compliant With ITU-T				
Receiver						
Center Wavelength	λ_r	1270	1550	1610	nm	
Sensitivity (PRBS2 ³¹ -1@9.95G, BER<10 ⁻¹²)				-24	dBm	
Overload (PRBS2 ³¹ -1@9.95G, BER<10 ⁻¹²)		-7			dBm	
Los Assert	LosA	-40			dBm	
Los Dessert	LosD			-25	dBm	
Los Hysteresis	LosH	0.5			dB	

Note:

1. Average optical power shall be measured using the methods specified in TIA/EIA-455-95.
2. Receiver sensitivity is informative. Stressed receiver sensitivity shall be measured with conformance test signal for BER = 1×10^{-12} .
3. Path penalty is intended as the power penalty of the interface between back-to-back and the maximum applied dispersion.

Electrical Characteristics

The following electrical characteristics are defined over the Recommended Operating Environment unless otherwise specified.

Parameter	Symbol	Min.	Typical	Max	Unit	Notes
Data Rate		9.953	9.953	11.3	Gbps	
Data Input Swing Differential/TX		120		820	mV	
Data Output Swing Differential/RX		380		850	mV	
Date Differential Impedance		90	100	110	Ω	
Output High		2.4		V _{cc}	V	
Output Low		0		0.4	V	
Input High		2		V _{cc} +0.3	V	
Input Low		0		0.8	V	
LOS Assert Time	T _{LOSA}			100	us	
LOS De-assert Time	T _{LOSD}			100	us	

Typical Interface Circuit

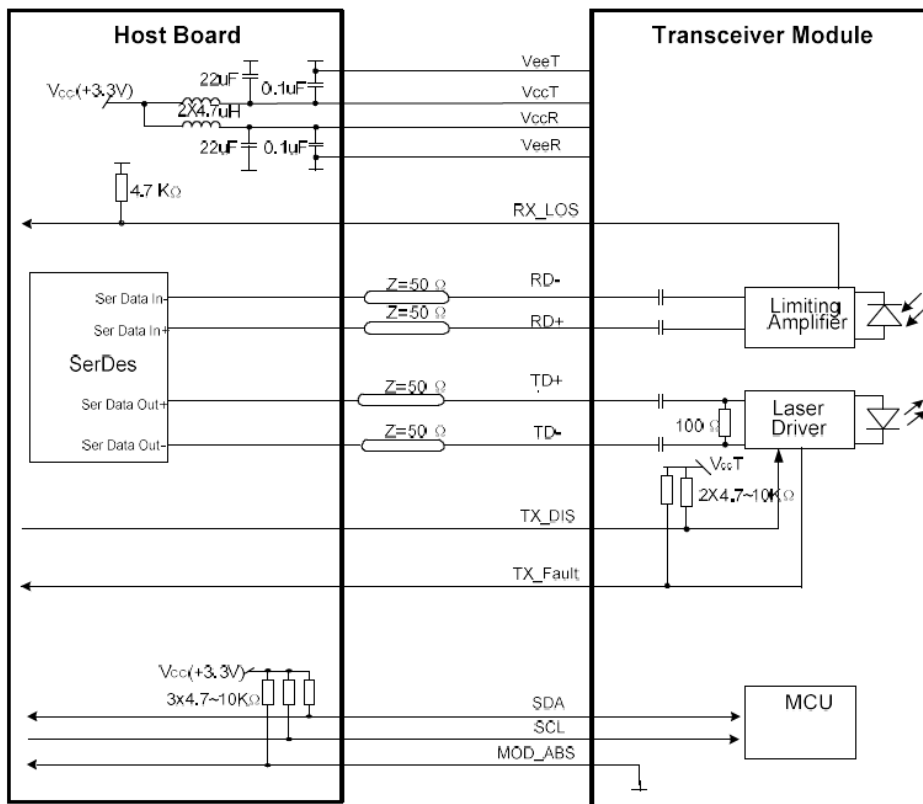

EEPROM Memory Map

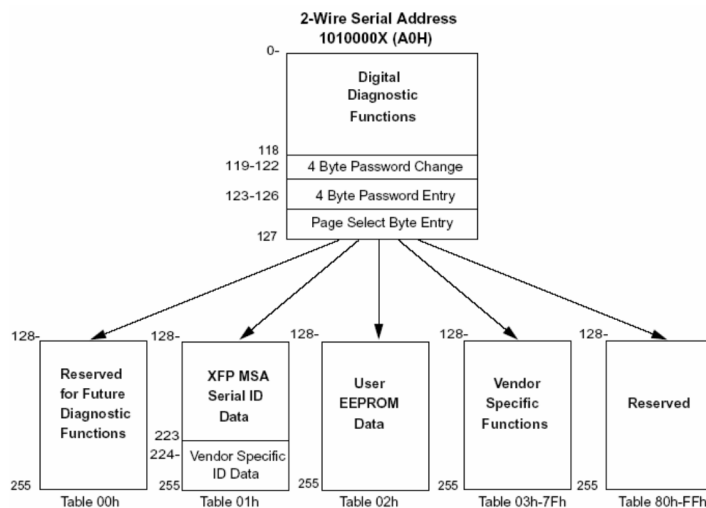

Mechanical Dimensions

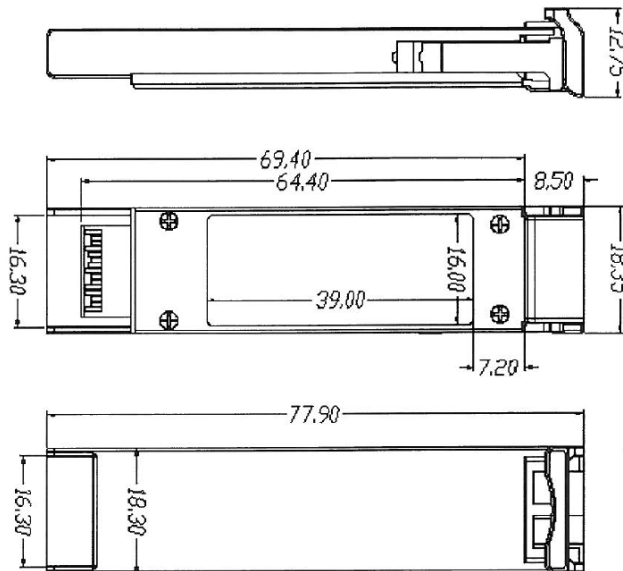

ESD

This transceiver is specified as ESD threshold 2kV for all electrical input pins, tested per MIL-STD-883, Method 3015.4 /JESD22-A114-A (HBM). However, normal ESD precautions are still required during the handling of this module. This transceiver is shipped in ESD protective packaging. It should be removed from the packaging and handled only in an ESD protected environment.

LASER Safety

This is a Class 1 Laser Product according to IEC/EN60825-1:2014 (Third Edition).. This product complies with 21 CFR 1040.10 and 1040.11 except for deviations pursuant to Laser Notice No. 50, dated (June 24, 2007)

Revision History

Date	Version	Description
03/12/2018	1.0	Initial release



Компания «ЭлектроПласт» предлагает заключение долгосрочных отношений при поставках импортных электронных компонентов на взаимовыгодных условиях!

Наши преимущества:

- Оперативные поставки широкого спектра электронных компонентов отечественного и импортного производства напрямую от производителей и с крупнейших мировых складов;
- Поставка более 17-ти миллионов наименований электронных компонентов;
- Поставка сложных, дефицитных, либо снятых с производства позиций;
- Оперативные сроки поставки под заказ (от 5 рабочих дней);
- Экспресс доставка в любую точку России;
- Техническая поддержка проекта, помощь в подборе аналогов, поставка прототипов;
- Система менеджмента качества сертифицирована по Международному стандарту ISO 9001;
- Лицензия ФСБ на осуществление работ с использованием сведений, составляющих государственную тайну;
- Поставка специализированных компонентов (Xilinx, Altera, Analog Devices, Intersil, Interpoint, Microsemi, Aeroflex, Peregrine, Syfer, Eurofarad, Texas Instrument, Miteq, Cobham, E2V, MA-COM, Hittite, Mini-Circuits, General Dynamics и др.);

Помимо этого, одним из направлений компании «ЭлектроПласт» является направление «Источники питания». Мы предлагаем Вам помощь Конструкторского отдела:

- Подбор оптимального решения, техническое обоснование при выборе компонента;
- Подбор аналогов;
- Консультации по применению компонента;
- Поставка образцов и прототипов;
- Техническая поддержка проекта;
- Защита от снятия компонента с производства.



Как с нами связаться

Телефон: 8 (812) 309 58 32 (многоканальный)

Факс: 8 (812) 320-02-42

Электронная почта: org@eplast1.ru

Адрес: 198099, г. Санкт-Петербург, ул. Калинина, дом 2, корпус 4, литера А.