



THREE FLANGE DUAL PRIMARY 5.0VA PC BOARD POWER TRANSFORMER

REV. Status

REVISION - 10/22/99 TS
REVISION A CHANGED F SEE PG. 2 11/22/99 TS
REVISION B CHANGED HI-POT, SAFETY AND SCHEMATIC. 05/21/01 MP
REVISION C REV'D HI-POT 09/20/04 MP
REVISION D ADDED RoHS & UPDATED LABEL 01/26/06 MP
REVISION E CHG TUV FILE # WAS 810/89 (EN60950 & VDE 0551). CLARIFIED PIN OUTS 04/19/07 YS
REVISION F UPDATED SAFETY 11/15/07 YS
REVISION G UPDATED SAFETY 10/19/12 MP
REVISION H SAFETY NOTES ADDED 03/20/13 MP

A. Electrical Specifications (@ 25 °C)

1. Maximum Power; 5.0VA
2. Primary Voltage and Frequency; 115/230VAC 50/60Hz
3. Secondary RMS Rating: See Table A
4. Voltage Regulation; 20% TYP @ full load to no load
5. Temperature Rise(normal op. cond.); 30°C TYP (45°C MAX)
6. A 10% Input Voltage change will proportionally affect transformer sec voltage. The max. allowed wdg temp under abnormal condition is 155°C
7. Insulation Resistance:
100MΩ MIN @ 500VDC, Pri to Sec, Pri to Core, Sec to Core
8. Dielectric Withstand: 3750Vrms 1 minute @ Pri to Sec
1500Vrms 1 minute @ Pri to Core, Sec to Core

B. Marking; includes input and output ratings (per sheet 2)

C. Safety:

Conforms to construction requirement of:
UL5085-1, -2; CSA No. 66.1, 66.2
(from Datecode 1244 and onwards).
UL506, UL1411
UL1446 (CLASS 130(B))
EN61558-1, -2-6

Safety certificate file reference:
UL E138028, E79781, E92957
CSA 175561
TUV (P.S.) 4478013415698



Non short-circuit proof safety isolating transformer.
Intended for mounting on PCBs and for building into end use-equipment. Fuse rating
Not intended for series/parallel connection with other transformers. (See tabulation)
Mounting hardware may reduce spacing in end use application.

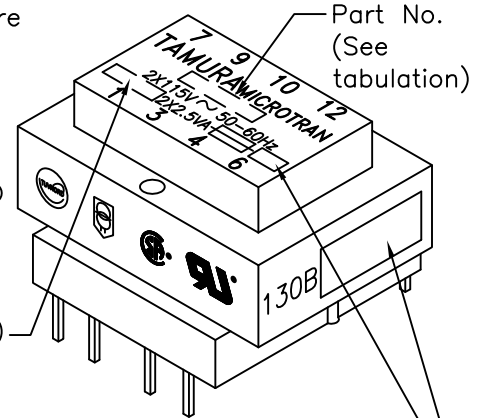

D. Mechanical Specifications;

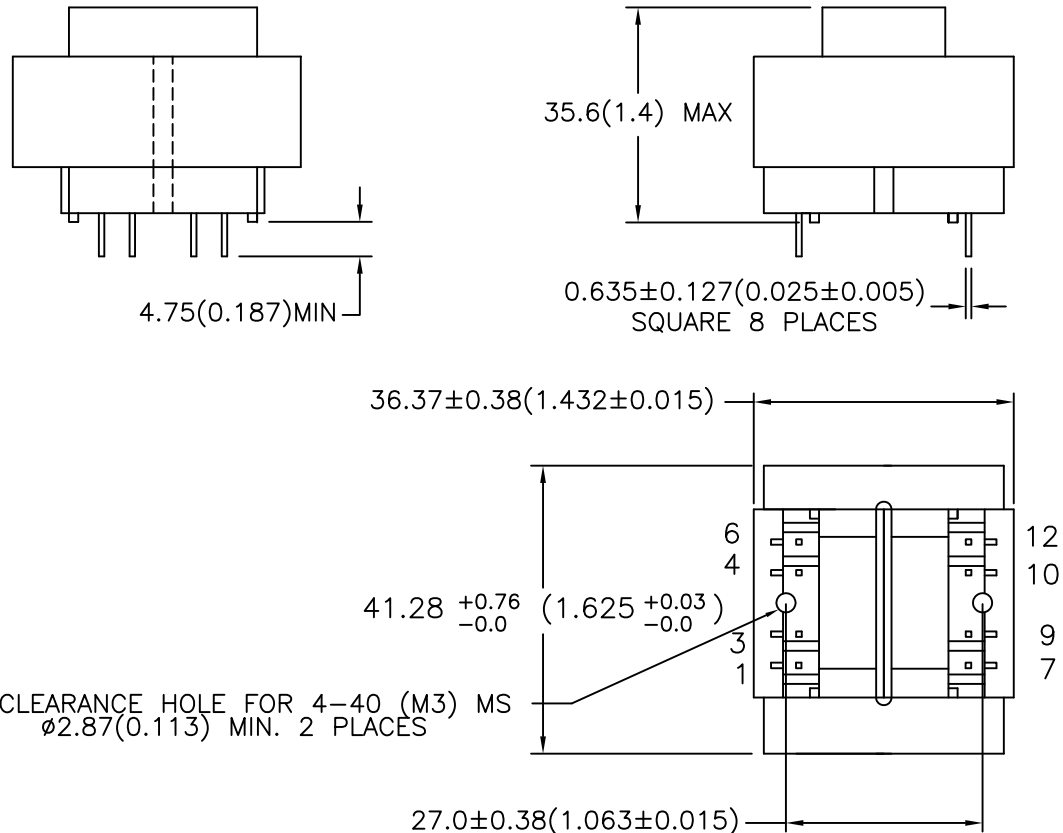

CLEARANCE HOLE FOR 4-40 (M3) MS
ø2.87(0.113) MIN. 2 PLACES

TOLERANCES (mm)	
≤ 4	± 0.2
4 ≤ 20	± 0.3
20 ≤ 50	± 0.4

PREPARED BY:

Mathi Pitchai

NOTE: BOARD WASHING IS NOT RECOMMENDED FOR THESE PARTS

ENGINEER:
Mathi Pitchai
SAFETY ENGINEER
B. Oconnel
APPROVED:
Peter Brune

DWG CONTROL NO. P-A1-12225 ACAD\MXFMR\A1122251.DWG	REV H	POWER TRANSFORMER
TAMURA CORPORATION OF AMERICA 43352 BUSINESS PARK DRIVE, TEMECULA, CA. 92590-6624 (951) 699-1270 FAX 9516769482		

PL5.0-XX-130B

MODEL SPECIFICATION

DIM: mm(In) SCL: 1/1 SH: 1 OF 2

PROPRIETARY NOTICE: THIS DRAWING PRINT OR DOCUMENT AND SUBJECT MATTER DISCLOSED HEREIN ARE PROPRIETARY ITEMS TO WHICH TAMURA RETAINS THE EXCLUSIVE RIGHT OF DISSEMINATION, REPRODUCTION, MANUFACTURE AND SALE. THIS DRAWING, PRINT OR DOCUMENT IS SUBMITTED IN CONFIDENCE FOR CONSIDERATION BY THE RECIPIENT ALONE UNLESS PERMISSION FOR FURTHER DISCLOSURE IS EXPRESSLY GRANTED IN WRITING.



MODEL NUMBER

PL5.0-XX-130B

E. Mounting Footprint;

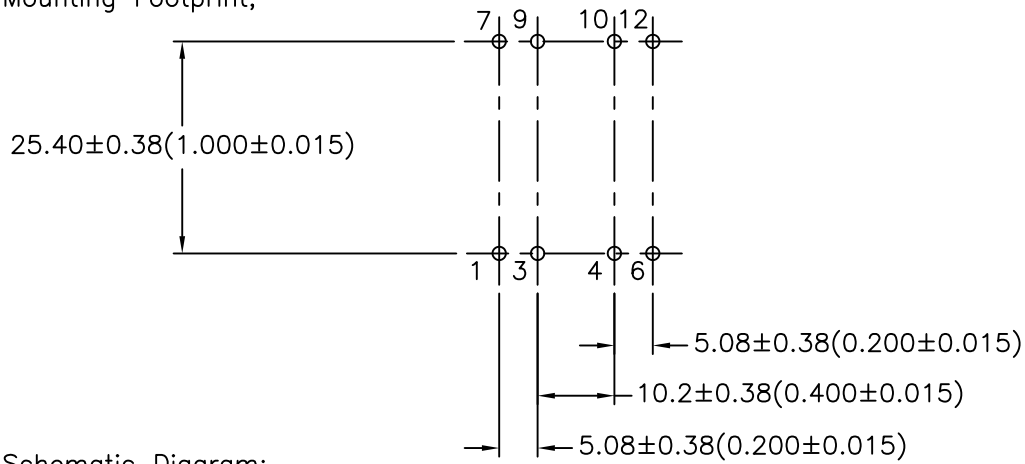

F. Schematic Diagram:

PRIMARY INPUT CONNECTIONS

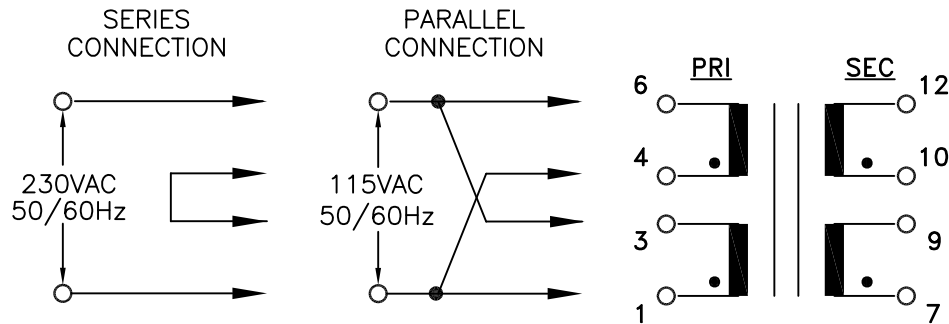

SECONDARY OUTPUT CONNECTIONS

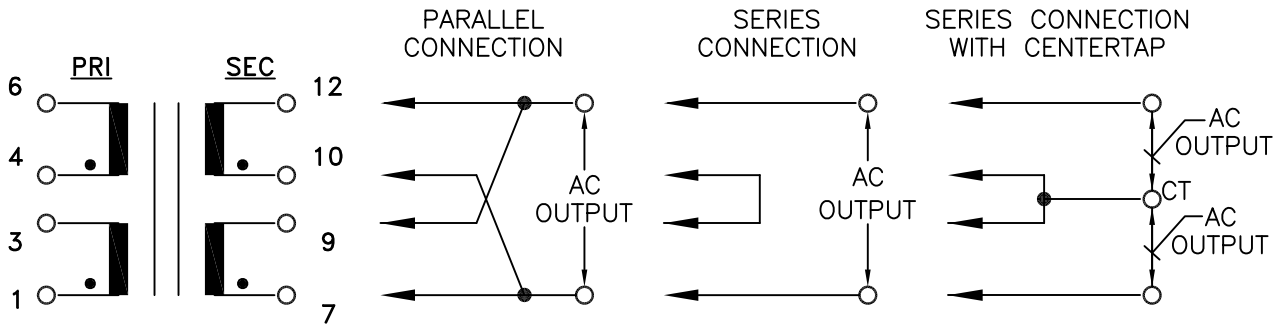

G. Table A

T= Time lag

PART NO.	PARALLEL		SERIES		SERIES WITH CT		OUTPUT	SECONDARY FUSE REQ'D EACH WINDING
	AC VOLTS	RMS AMPS	AC VOLTS	RMS AMPS	AC VOLTS	RMS AMPS		
PL5.0-10-130B	5.0	1.00	10.0	0.50	5.0-CT-5.0	0.50	2X5.0V	T 0.50A
PL5.0-12-130B	6.3	0.80	12.6	0.40	6.3-CT-6.3	0.40	2X6.3V	T 0.40A
PL5.0-16-130B	8.0	0.62	16.0	0.31	8.0-CT-8.0	0.31	2X8.0V	T 0.315A
PL5.0-20-130B	10.0	0.50	20.0	0.25	10.0-CT-10.0	0.25	2X10.0V	T 0.25A
PL5.0-24-130B	12.0	0.42	24.0	0.21	12.0-CT-12.0	0.21	2X12.0V	T 0.25A
PL5.0-28-130B	14.0	0.36	28.0	0.18	14.0-CT-14.0	0.18	2X14.0V	T 0.20A
PL5.0-36-130B	18.0	0.28	36.0	0.14	18.0-CT-18.0	0.14	2X18.0V	T 0.16A

PREPARED BY:
Mathi Pitchai

ENGINEER:
Mathi Pitchai

SAFETY ENGINEER
B. Oconnel

APPROVED:
Peter Brune

DWG CONTROL NO. REV
P-A1-12225 H
ACAD\MXFMR\A1122252.DWG

POWER TRANSFORMER

TAMURA CORPORATION OF AMERICA
43352 BUSINESS PARK DRIVE, TEMECULA, CA. 92590-6624
(951) 699-1270 FAX 9516769482

PL5.0-XX-130B

MODEL SPECIFICATION

DIM: mm(In) SCL: 1/1 SH: 2 OF 2

PROPRIETARY NOTICE: THIS DRAWING PRINT OR DOCUMENT AND SUBJECT MATTER DISCLOSED HEREIN ARE PROPRIETARY ITEMS TO WHICH TAMURA RETAINS THE EXCLUSIVE RIGHT OF DISSEMINATION, REPRODUCTION, MANUFACTURE AND SALE. THIS DRAWING, PRINT OR DOCUMENT IS SUBMITTED IN CONFIDENCE FOR CONSIDERATION BY THE RECIPIENT ALONE UNLESS PERMISSION FOR FURTHER DISCLOSURE IS EXPRESSLY GRANTED IN WRITING.



Компания «ЭлектроПласт» предлагает заключение долгосрочных отношений при поставках импортных электронных компонентов на взаимовыгодных условиях!

Наши преимущества:

- Оперативные поставки широкого спектра электронных компонентов отечественного и импортного производства напрямую от производителей и с крупнейших мировых складов;
- Поставка более 17-ти миллионов наименований электронных компонентов;
- Поставка сложных, дефицитных, либо снятых с производства позиций;
- Оперативные сроки поставки под заказ (от 5 рабочих дней);
- Экспресс доставка в любую точку России;
- Техническая поддержка проекта, помощь в подборе аналогов, поставка прототипов;
- Система менеджмента качества сертифицирована по Международному стандарту ISO 9001;
- Лицензия ФСБ на осуществление работ с использованием сведений, составляющих государственную тайну;
- Поставка специализированных компонентов (Xilinx, Altera, Analog Devices, Intersil, Interpoint, Microsemi, Aeroflex, Peregrine, Syfer, Eurofarad, Texas Instrument, Miteq, Cobham, E2V, MA-COM, Hittite, Mini-Circuits, General Dynamics и др.);

Помимо этого, одним из направлений компании «ЭлектроПласт» является направление «Источники питания». Мы предлагаем Вам помощь Конструкторского отдела:

- Подбор оптимального решения, техническое обоснование при выборе компонента;
- Подбор аналогов;
- Консультации по применению компонента;
- Поставка образцов и прототипов;
- Техническая поддержка проекта;
- Защита от снятия компонента с производства.



Как с нами связаться

Телефон: 8 (812) 309 58 32 (многоканальный)

Факс: 8 (812) 320-02-42

Электронная почта: org@eplast1.ru

Адрес: 198099, г. Санкт-Петербург, ул. Калинина, дом 2, корпус 4, литера А.