



# 8D Power Series



# 8D Power Series



## SOURIAU

The extreme environments interconnect specialist «from deep sea to deep space»

The company designs, manufactures and markets high performance interconnect solutions for severe environments from industrial broadline and universal ranges to complex system with integrated functions: filtering, high speed data transmission, hermetic seal, separation mechanism, remote handling, underwater mating, ...



Industrial



Aeronautical



Equipment & System

The dedicated end markets for SOURIAU's products are aeronautical, defense-space and industrial.



Railway  
Geophysics  
Manufacturing environment  
Instrumentation  
Automation & process  
Motosport



Civil & military aircraft  
Helicopter  
Weapon delivery system  
Avionics



Military marine  
Communications  
Satellites  
Launcher & missile

SOURIAU was established in 1917 and has been created by successive acquisitions of the industrial, aeronautical, defense and space activities of SOURIAU, JUPITER and BURNDY.

The Group's products are engineered and manufactured in the USA and Dominican Republic, Europe and Morocco, Japan and India, and sold by a worldwide sales and marketing organization, and in addition to SOURIAU's offices, a large network of licensed distributors and agents.

SOURIAU complies with most of national and international Quality Assurance Standards, production unit with ISO 14001

**Quality Certificate  
Management System**

**ISO 9001**

**Environment Certificate  
Management System**

**ISO 14001**

**Quality Certificate  
Management System**

**Aeronautic Industry : EN 9100**

# 8D Power Series



## Presentation

8D power series is a range extension of standard aeromil product line to address high power supply in harsh environment for civil and military aeronautics market.

Thanks to its unique contact design (socket with a braid) these products can be used wherever very high power supply is required in environment where vibration and temperature are high.

Typical applications can be motor of electro hydraulic or electro mechanical actuators (located on Aircraft wings and tail or in the thrust reverser actuation system).

8D range features 6 different layouts in 4 shell sizes (composite or aluminum) with contacts from size 8 to size 4 enabling current rating up to 80 Amps.

## Contents

|   |    |
|---|----|
| • Company profile .....                 | 2  |
| • Presentation .....                    | 3  |
| • Technical features and benefits ..... | 4  |
| • Ordering information .....            | 6  |
| • Layouts .....                         | 7  |
| • Dimensions .....                      | 8  |
| • Contacts and sealing boot .....       | 9  |
| • Tooling .....                         | 10 |

# 8D Power Series



## Technical features and benefits

### A unique contact design with a braid socket

- Enabling 20 contact points for a size 4 contact vs 2 or 3 for a standard socket,
- Allowing 20 % more intensity as compared to standard socket,
- Excellent vibration withstanding,
- Insure excellent crimping (crimping bucket can be heat treated to insure good plasticity without affecting the active part elasticity insured by the braid - added after heat treatment).

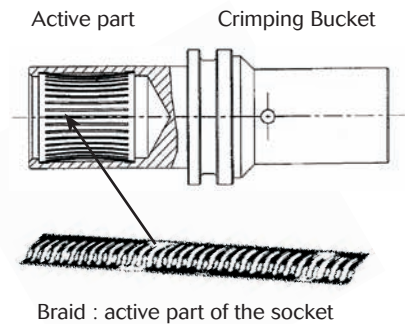

20 contact points on the pin for a #4 contact

Cut of a contact mated pair



### A versatile individual sealing on the cable

- Sealing on the cable done thanks to a sealing boot,
- Same connector can accommodate a wide range of cable diameter.

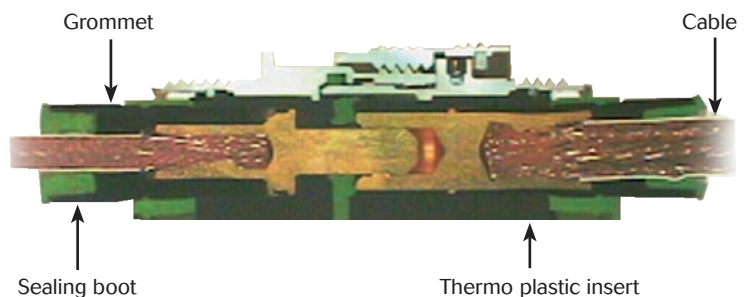

Longitudinal cut of a connector

### A contact technology integrated in well proven standard aeromil connectors

- Up to 260°C service temperature,
- Up to 60G vibration withstanding.





# 8D Power Series



## Description

- Quick screw coupling connector with removable crimp contact.
- Designed to be used in severe environments, fluid resistance, high shock and vibration.
- Shell available in, aluminium, composite, Stainless steel, Titanium & Bronze.
- Six layouts with different current rating.
- Consult us for power hermetic version.

## Applications

- Power supply in harsh environment: Electro Hydraulic actuator on Aircraft wings, Electro Mechanical actuator for Aircraft Thrust Reverser...

## Technical features

### Mechanical

- **Shell:** Aluminum alloy, Composite, Bronze, Stainless steel, Titanium.
- **Plating:**
  - Olive green cadmium (W/J),
  - Nickel (F/M/TF/S),
  - Without plating (X for composite, TT for titanium and JVS for Bronze),
  - Passivated (K).
- **Grommet and seal:** Silicon elastomer.
- **Insulator:** Thermoset.
- **Contact body:** Copper Alloy.
- **Contact retention:**
  - #4 = 200N
  - #8 = 111N.
- **Shock:** 300g during 3ms.
- **Endurance:** 500 mating / unmating operations.
- **Vibration:** As per MIL DTL 38999.

### Electrical

- **Dielectric withstanding:**  
Test voltage rating (Vrms).

| Service | Sea level | at 21 000 m |
|---------|-----------|-------------|
| M       | 1 300     | 800         |
| I       | 1 800     | 1 000       |

- **Insulation Resistance:**  
5000 M $\Omega$  under 500 Vdc.
- **Max current rating per contact:**
  - #4 = 80A
  - #8 = 45A.
- **Contact resistance:**
  - #4 = 2m $\Omega$
  - #8 = 3M $\Omega$ .
- **Shielding:** As per MIL DTL 38999.
- **Electrical continuity:**
  - W = 2.5 m $\Omega$ ,
  - F = 1m $\Omega$ ,
  - J, M = 3 m $\Omega$ ,
  - JVS = 5 m $\Omega$ .

### Environmental

- **Temperature range:**
  - W, J, X, JVS = - 65°C +175°C,
  - F, M, K, S, TT, TF = - 65°C +200°C.
- **Sealing:** As per MIL DTL 38999.
- **Damp Heat:** As per MIL DTL 38999.
- **Salt Spray:**
  - W, TT, TF, K, JVS = 500 hours,
  - F, S = 48 hours,
  - J,M,X = 2000 hours.
- **Fire resistance:**  
As per EN 2591 - c 17 method A.
- **Resistance to fluid:**  
As per MIL DTL 38999.

# 8D Power Series



## Ordering information

|   |    |   |   |    |   |    |   |   |     |
|---|----|---|---|----|---|----|---|---|-----|
| Basic Series  | 8D | 0 | - | 11 | W | 80 | P | N | 251 |
| <b>Style:</b>   |    |   |   |    |   |    |   |   |     |
| 0: Square flange receptacle   |    |   |   |    |   |    |   |   |     |
| 5: Plug with RFI shielding  |    |   |   |    |   |    |   |   |     |
| 7: Jam nut receptacle   |    |   |   |    |   |    |   |   |     |
| <b>Type:</b> Crimp contact  |    |   |   |    |   |    |   |   |     |
| <b>Shell size:</b> 11 - 17 - 21 - 25  |    |   |   |    |   |    |   |   |     |
| <b>Plating (according shell material - see below):</b>                            |    |   |   |    |   |    |   |   |     |
| <b>Aluminum shell:</b>  |    |   |   |    |   |    |   |   |     |
| W: Olive green cadmium  |    |   |   |    |   |    |   |   |     |
| F: Nickel   |    |   |   |    |   |    |   |   |     |
| <b>Composite shell:</b>   |    |   |   |    |   |    |   |   |     |
| J: Olive green cadmium  |    |   |   |    |   |    |   |   |     |
| M: Nickel   |    |   |   |    |   |    |   |   |     |
| X: Without plating  |    |   |   |    |   |    |   |   |     |
| <b>Stainless steel shell:</b>   |    |   |   |    |   |    |   |   |     |
| K: Corrosion resistant  |    |   |   |    |   |    |   |   |     |
| S: Nickel   |    |   |   |    |   |    |   |   |     |
| <b>Titanium shell:</b>  |    |   |   |    |   |    |   |   |     |
| TT: Without plating   |    |   |   |    |   |    |   |   |     |
| TF: Nickel  |    |   |   |    |   |    |   |   |     |
| <b>Contact layouts:</b> See p.8   |    |   |   |    |   |    |   |   |     |
| <b>Contact style:</b>   |    |   |   |    |   |    |   |   |     |
| P: Pin contact                      A: Male connector supplied without contact    |    |   |   |    |   |    |   |   |     |
| S: Socket contact                B: Female connector supplied without contact     |    |   |   |    |   |    |   |   |     |
| <b>Orientation:</b> N - A - B - C - D - E   |    |   |   |    |   |    |   |   |     |
| <b>Specification:</b>   |    |   |   |    |   |    |   |   |     |
| 251: To be added for some layouts to be supplied with power contacts (see page 8) |    |   |   |    |   |    |   |   |     |

## Ordering information (Marine Bronze serie)

|   |     |    |   |    |    |   |   |     |
|---|-----|----|---|----|----|---|---|-----|
| Basic Series  | JVS | 16 | A | 11 | 80 | P | N | 251 |
| <b>Style:</b>   |     |    |   |    |    |   |   |     |
| 00: Square flange receptacle  |     |    |   |    |    |   |   |     |
| 07: Jam nut receptacle  |     |    |   |    |    |   |   |     |
| 16: Plug  |     |    |   |    |    |   |   |     |
| <b>Material:</b>  |     |    |   |    |    |   |   |     |
| A: Bronze shell material  |     |    |   |    |    |   |   |     |
| <b>Shell size:</b> 11 - 17 - 21 - 25  |     |    |   |    |    |   |   |     |
| <b>Contact layouts:</b> See p.8   |     |    |   |    |    |   |   |     |
| <b>Contact style:</b>   |     |    |   |    |    |   |   |     |
| P: Pin contact                      A: Male connector supplied without contact    |     |    |   |    |    |   |   |     |
| S: Socket contact                B: Female connector supplied without contact     |     |    |   |    |    |   |   |     |
| <b>Orientation:</b> N - A - B - C - D - E   |     |    |   |    |    |   |   |     |
| <b>Specification:</b>   |     |    |   |    |    |   |   |     |
| 251: To be added for some layouts to be supplied with power contacts (see page 8) |     |    |   |    |    |   |   |     |

# 8D Power Series



## Layouts

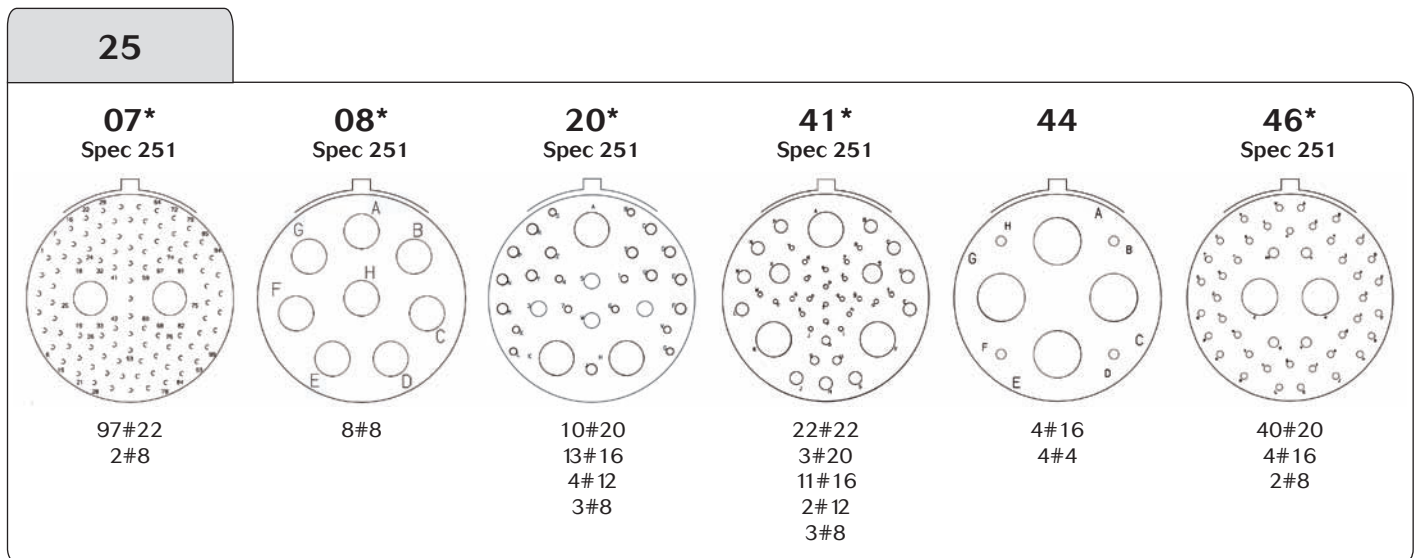
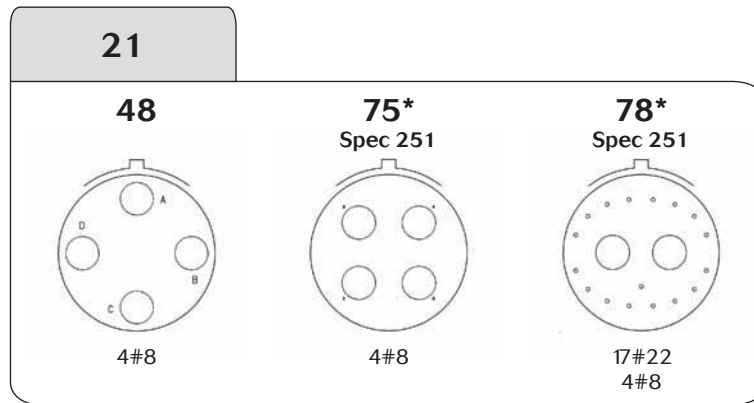
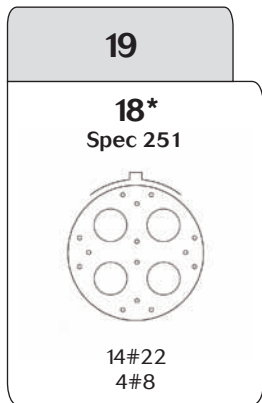
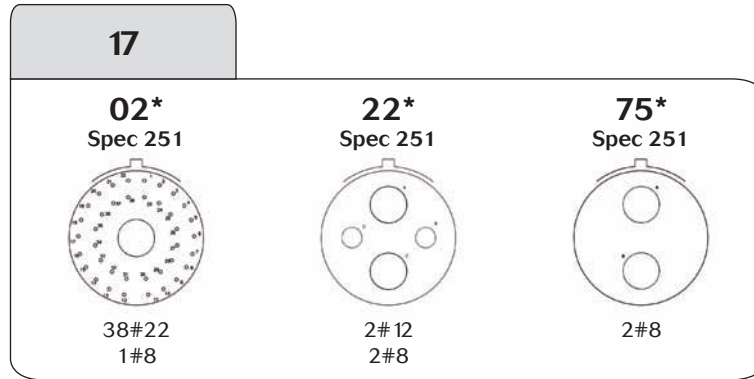
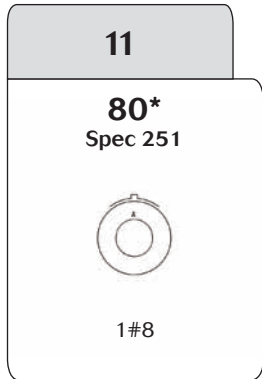

\* For classes F, W, K, S only

# 8D Power Series



## Dimension plug type 5 - for all material

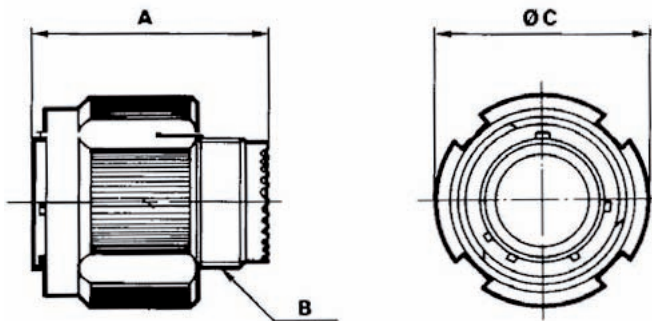

| Shell size | 11        | 17        | 21        | 25        |
|------------|-----------|-----------|-----------|-----------|
| A max      | 31        | 31        | 31        | 31        |
| B (thread) | M 15x1-6g | M 25x1-6g | M 31x1-6g | M 37x1-6g |
| C max      | 25.00     | 36.5      | 42.5      | 48.4      |

## Dimension receptacle type 0 - for all material

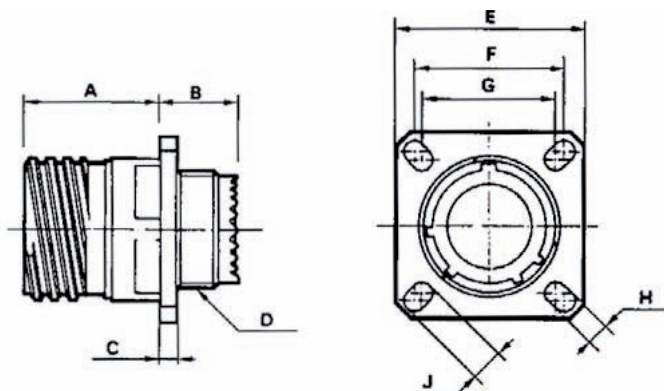

| Shell size | 11        | 17        | 21        | 25        |
|------------|-----------|-----------|-----------|-----------|
| A max      | 20.83     | 20.83     | 20.10     | 20.10     |
| B max      | 12.00     | 12.00     | 12.00     | 12.00     |
| C max      | 2.50      | 3.65      | 4.35      | 4.35      |
| D (thread) | M 15x1-6g | M 25x1-6g | M 31x1-6g | M 37x1-6g |
| E ±0.3     | 26.20     | 33.30     | 39.70     | 46.00     |
| F          | 20.62     | 26.97     | 31.75     | 38.10     |
| G          | 18.26     | 24.61     | 29.36     | 34.93     |
| H ±0.20    | 3.25      | 3.25      | 3.25      | 3.91      |
| J ±0.20    | 4.93      | 4.93      | 4.93      | 6.15      |

## Dimension Jam nut type 7 - for all material (excepted composite)

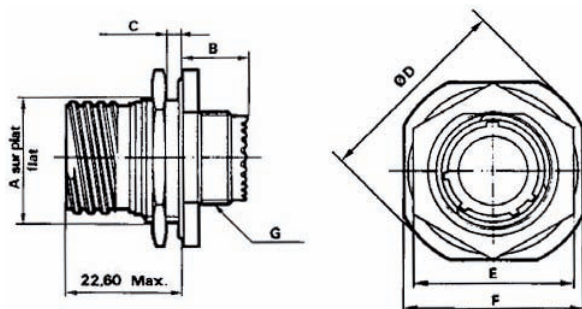

| Shell size    | 11        | 17        | 21        | 25        |
|---------------|-----------|-----------|-----------|-----------|
| A +0.10 -0.15 | 19.07     | 30.18     | 36.50     | 42.85     |
| B max         | 9.90      | 9.90      | 9.90      | 9.90      |
| C max         | 3.20      | 3.20      | 3.20      | 3.20      |
| D max         | 35.20     | 44.80     | 52.70     | 59.00     |
| E max         | 27.00     | 37.00     | 46.00     | 51.23     |
| F 0.4         | 31.80     | 41.30     | 49.20     | 55.60     |
| G (thread)    | M 15x1-6g | M 25x1-6g | M 31x1-6g | M 37x1-6g |



# 8D Power Series



## Contacts

Socket contact

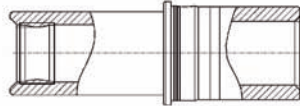
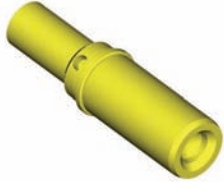

Pin contact

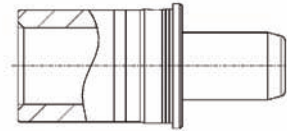
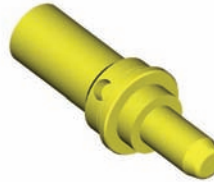

| Contact size           | Contact type | Contact reference | Cable                            |                | Protection | Dimensions |      |
|------------------------|--------------|-------------------|----------------------------------|----------------|------------|------------|------|
|                        |              |                   | Cable size                       | Cable material |            | L          | D    |
| #4                     | Male         | 8599-7534         | #4-5 or 10-16mm <sup>2</sup> **  | Copper         | Au         | 9.70       | 5.74 |
|                        | Female       | 8599-7535         |                                  |                |            | 16.58      | 8.50 |
|                        | Male         | 8599-7598 900 *   | for cable 25mm <sup>2</sup> (#3) | Copper         | Au         | 9.70       | 5.74 |
|                        | Female       | 8599-7599 900 *   |                                  |                |            | 16.58      | 8.50 |
| #4 with reduced barrel | Male         | 8599-7528 900     | #6 or 10mm <sup>2</sup> **       | Copper         | Au         | 9.70       | 5.74 |
|                        | Female       | 8599-7529 900     |                                  |                |            | 16.58      | 8.50 |
| #8<br>JVS only         | Male         | 8599-7544         | #8 or 10 **                      | Copper         | Au         | 9.60       | 3.64 |
|                        | Female       | 8599-7541         |                                  |                |            | 16.00      | 7.30 |
| #8                     | Male         | 8599-7580         | #8 or 10 **                      | Copper         | Au         | 9.60       | 3.64 |
|                        | Female       | 8599-7581         |                                  |                |            | 16.00      | 7.30 |

\* Not included in connector P/N. Must be ordered separately.

\*\* To be used with crimping bucket reducer.

## Sealing boot and crimping bucket reducer



| Contact size | Cable size        | Cable material | Sealing boot reference |
|--------------|-------------------|----------------|------------------------|
| #4           | 16mm <sup>2</sup> | Copper         | 8599-4594              |
|              | 10mm <sup>2</sup> |                | 8599-4593              |
| #8           | #8                | Copper         | 8599-4542              |
|              | #10               |                | 8599-4547              |

| Contact size | Cable size        | Reducing sleeve reference |
|--------------|-------------------|---------------------------|
| #4           | 10mm <sup>2</sup> | 8400-2352A                |
| #8           | #10               | 8599-7545                 |

# 8D Power Series



## Tooling

| Contact size | Contact type    | Contact reference | Cable AWG                      | Crimping tool | Die set      | Locator      | Contact extraction tool (metallic) | Contact extraction tool (plastic) |
|--------------|-----------------|-------------------|--------------------------------|---------------|--------------|--------------|------------------------------------|-----------------------------------|
| #4           | Male            | 8599-7534         | #4-5 or 10-16mm <sup>2</sup> * | M22520/23-01  | M22520/23-04 | M22520/23-11 | 8533-8175                          | M81969/14-07                      |
|              | Female          | 8599-7535         | #4-5 or 10-16mm <sup>2</sup> * | M22520/23-01  | M22520/23-04 | M22520/23-11 | 8533-8175                          | M81969/14-07                      |
| #8           | Male            | 8599-7544         | #8 or 10 *                     | M22520/23-01  | M22520/23-02 | 8599-9601    | 8660-197                           | M81969/14-12                      |
|              | JVS only Female | 8599-7541         | #8 or 10 *                     | M22520/23-01  | M22520/23-02 | 8599-9601    | 8660-197                           | M81969/14-12                      |
| #8           | Male            | 8599-7580         | #8 or 10 *                     | M22520/23-01  | M22520/23-02 | 8599-9601    | 8660-197                           | M81969/14-12                      |
|              | Female          | 8599-7581         | #8 or 10 *                     | M22520/23-01  | M22520/23-02 | 8599-9601    | 8660-197                           | M81969/14-12                      |

Manual hand tool also existing fo power contacts #8.  
 \* To be used with crimping bucket reductor.

### Automatic tool for contacts #4 & #8



Crimping tool (M22520/23-01)



Die set (M22520/23-02)



Locator (M22520/23-11)

### Manual hand tool for contacts #8



Crimping tool (M300 BT)



Locator (SP 593)

### Extraction tool

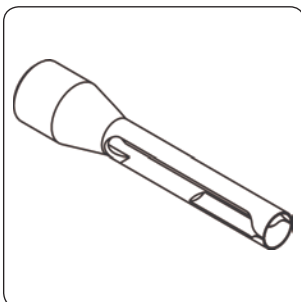

Metallic extraction tool for #4 (8533-8175)

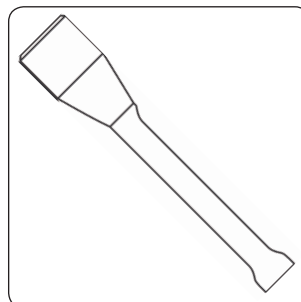

Metallic extraction tool for #8 (8660-197)

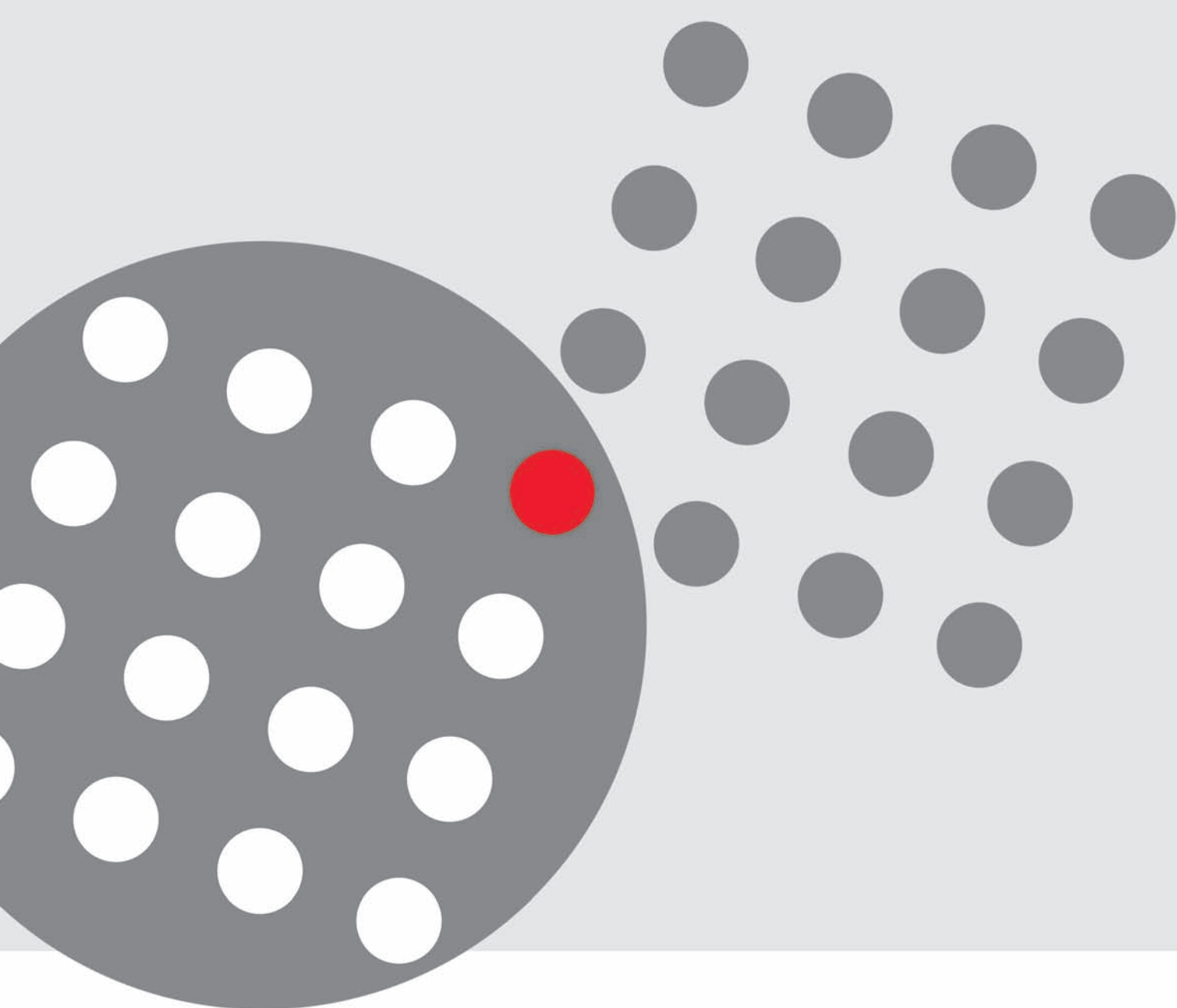

[www.souriau.com](http://www.souriau.com)  
[contactmilaero@souriau.com](mailto:contactmilaero@souriau.com)





Компания «ЭлектроПласт» предлагает заключение долгосрочных отношений при поставках импортных электронных компонентов на взаимовыгодных условиях!

Наши преимущества:

- Оперативные поставки широкого спектра электронных компонентов отечественного и импортного производства напрямую от производителей и с крупнейших мировых складов;
- Поставка более 17-ти миллионов наименований электронных компонентов;
- Поставка сложных, дефицитных, либо снятых с производства позиций;
- Оперативные сроки поставки под заказ (от 5 рабочих дней);
- Экспресс доставка в любую точку России;
- Техническая поддержка проекта, помощь в подборе аналогов, поставка прототипов;
- Система менеджмента качества сертифицирована по Международному стандарту ISO 9001;
- Лицензия ФСБ на осуществление работ с использованием сведений, составляющих государственную тайну;
- Поставка специализированных компонентов (Xilinx, Altera, Analog Devices, Intersil, Interpoint, Microsemi, Aeroflex, Peregrine, Syfer, Eurofarad, Texas Instrument, Miteq, Cobham, E2V, MA-COM, Hittite, Mini-Circuits, General Dynamics и др.);

Помимо этого, одним из направлений компании «ЭлектроПласт» является направление «Источники питания». Мы предлагаем Вам помощь Конструкторского отдела:

- Подбор оптимального решения, техническое обоснование при выборе компонента;
- Подбор аналогов;
- Консультации по применению компонента;
- Поставка образцов и прототипов;
- Техническая поддержка проекта;
- Защита от снятия компонента с производства.



#### Как с нами связаться

**Телефон:** 8 (812) 309 58 32 (многоканальный)

**Факс:** 8 (812) 320-02-42

**Электронная почта:** [org@eplast1.ru](mailto:org@eplast1.ru)

**Адрес:** 198099, г. Санкт-Петербург, ул. Калинина, дом 2, корпус 4, литера А.