

SERIES 67B Hall Effect Joystick

FEATURES

- Proportional output joystick, pushbutton, & momentary rotary select in one device
- Shaft and panel seal to IP67
- Rugged and compact: 1.25 inch diameter
- Long operational life
- RoHS compliant
- i²c output (see www.grayhill.com for User Manual)

APPLICATIONS

- Medical imaging - X-ray, CT scanner, MRI patient tables
- Military vehicles - display navigation
- Handheld remote control devices
- Material handling equipment and crane operations



Actual Size

DIMENSIONS in inches [millimeters]

with sealing boot

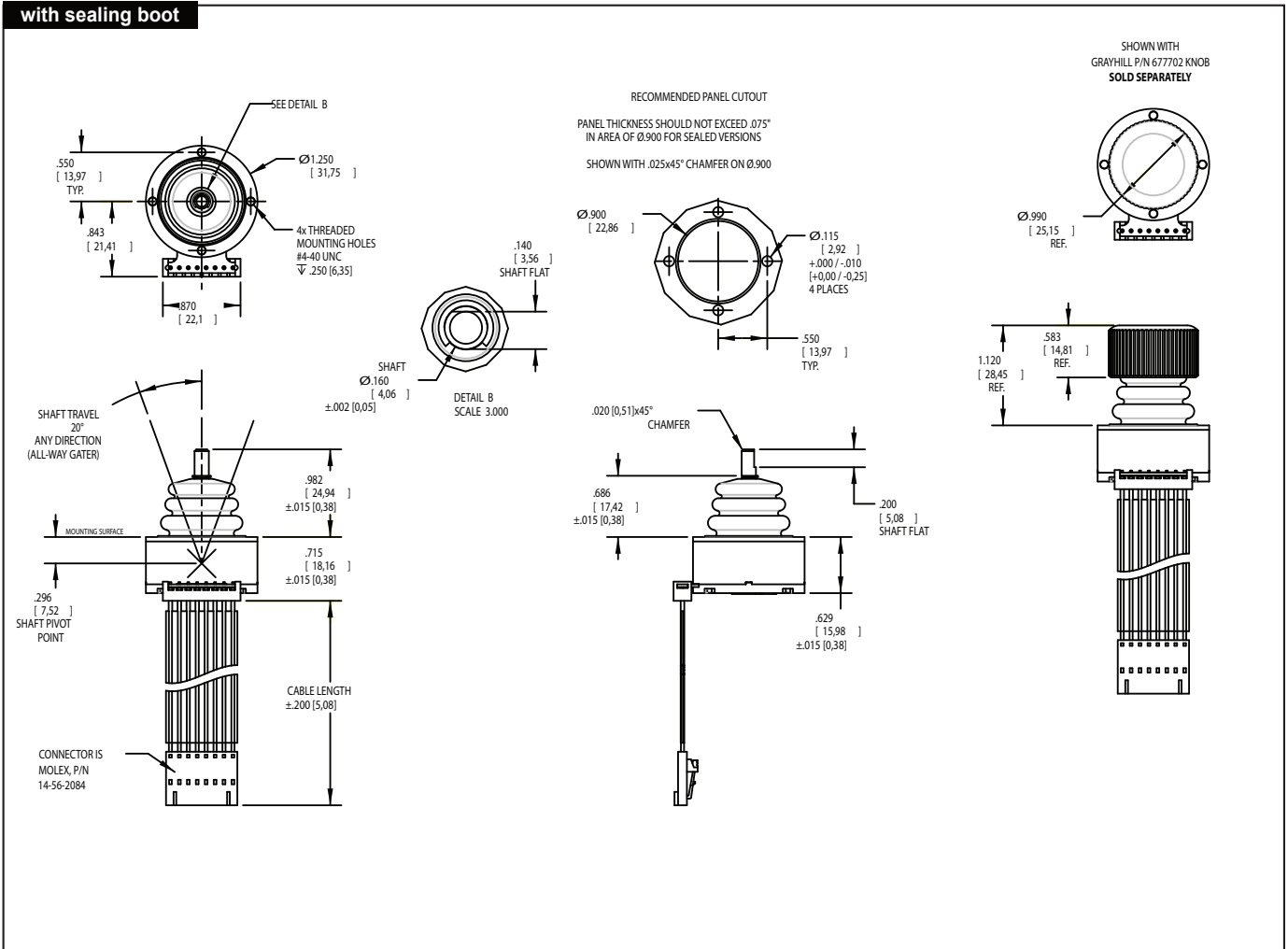

DIMENSIONS in inches [millimeters]

without sealing boot

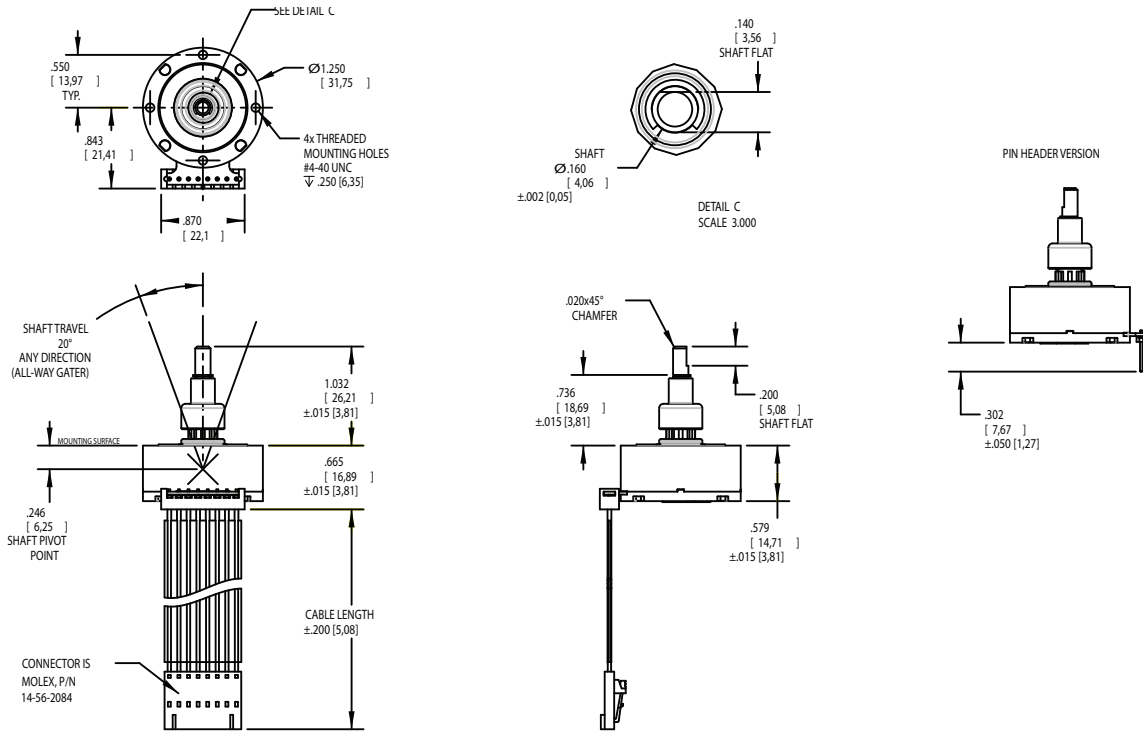

BLOCK DIAGRAM & JOYSTICK OUTPUT WAVEFORM

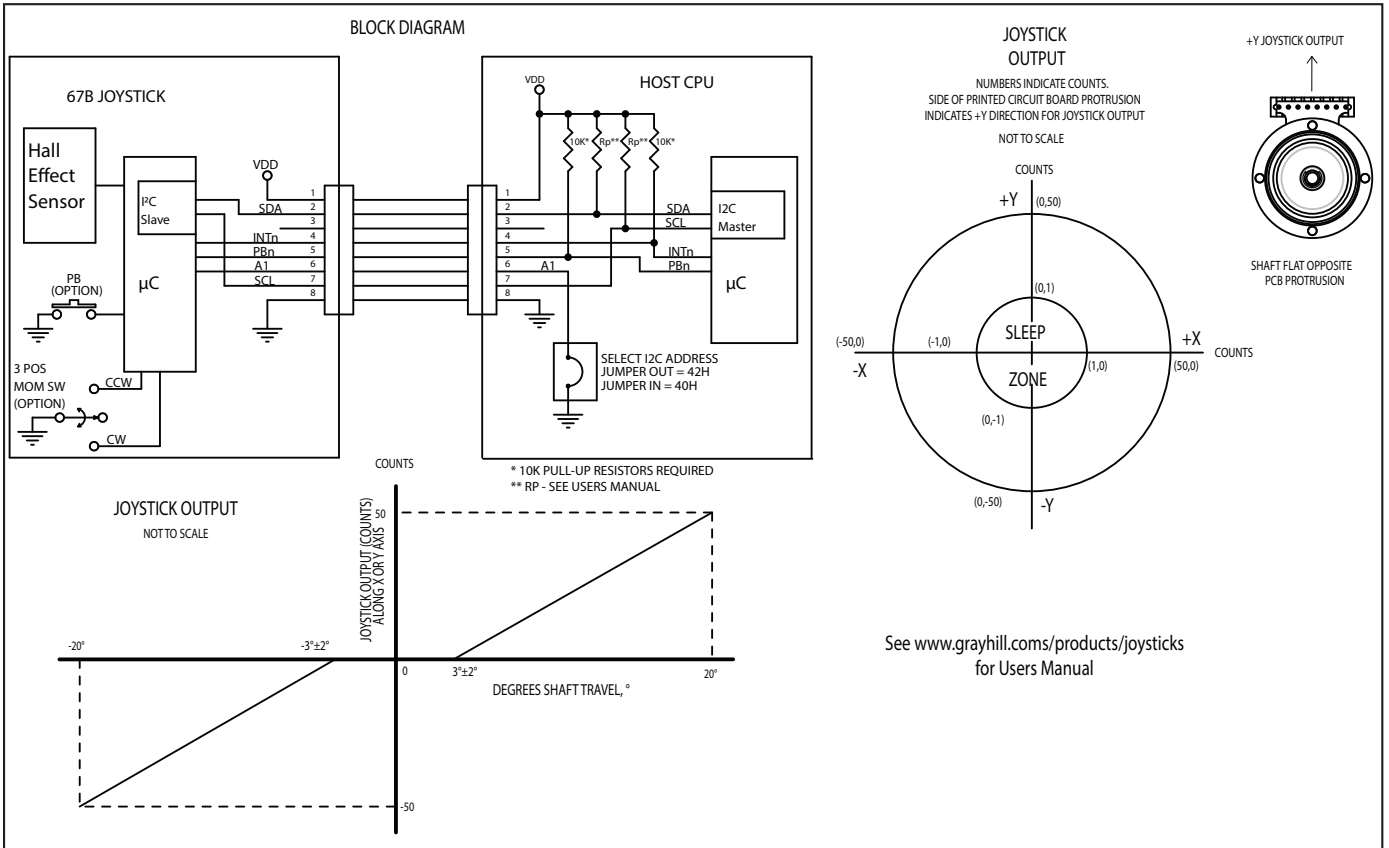

SPECIFICATIONS

Electrical Ratings

Supply Voltage (VVD): 3.3V ± 0.3V
High Level Input Voltage (VIH, Min): 0.7*VDD on SCL & SDA / 0.25*VDD+0.8 on AI
Low Level Input Voltage (VIL, Max): 0.3*VDD on SCL & SDA / 0.15*VDD on AI
Current Draw In Active Mode (IDD1): 3mA Maximum @ VDD = 3.3V (J & P options only)
Current Draw In Sleep Mode (IDD2): 100uA Maximum @ VDD = 3.3V (J & P options only)
Current Draw in Active Mode (IDD3): 4mA Maximum @ VDD = 3.3V (R option has active mode only)
Typical Operating Current: 4.0 mA at Vcc = 3.3V, T = 25°C
Maximum Operating Current: 7.0 mA over 3.0 ≤ Vcc ≤ 3.6V, -40°C ≤ T ≤ 85°C
Maximum Current Sunk By Any I/O Pin: 25mA
Leakage Current: ±5 nA Typ., ±125 nA Max
Low Level Output Voltage (VOL): 0.6V On INTn & SDA @ IOL = 6mA, @ VDD = 3.3V
Measurement Frequency (Active Mode): 50 Samples/Sec
Response Time, Active Mode (T1): 20ms*
Response Time, Sleep Mode (T2): 80ms*
Output @ Maximum Joystick Deflection (XMax, YMax): 50 Units
Output With Joystick Shaft Released (Center Position): (0,0)
Nominal Startup Time (TP, W): 300ms

Physical & Mechanical Ratings

Vibration: Random, Meets MIL-STD-810G, Method 514.6, Procedure I
Mechanical Shock: Meets per MIL-STD 202, Method 213B Test Condition A
Transit Drop: Meets per MIL-ST-810G, Method 516.6, Procedure II
Terminal Strength: 10 lbs. Minimum, Tested per MIL-STD-202, Method 211A
Push-Out Force: 60 lbs. Minimum
Pull-Out Force: 60 lbs. Minimum
Shaft Impact: 0.5 lb. Weight dropped 20x from height of 1m
Shaft Side-Load: 45 lbs. Minimum
Mounting Torque: 3-5 in-lbs recommended, 8 in-lbs. Maximum
Joystick Actuation Force: 300g Peak ± 25%
Joystick Life: 1 million cycles minimum**
Pushbutton Life: 1 million actuations, minimum
Rotational Life: 1 million turns, minimum in each direction

Materials and Finishes

Housing: Thermoplastic
Backplate: Thermoplastic
Lockwashers: 304 Stainless Steel
Hex Nuts: 303 Stainless Steel
Shim Washers: 304 Stainless Steel
Shaft: 303 Stainless Steel
Cable Assembly: 26 AWG Stranded Copper Conductors
Connector Body: Thermoplastic
Terminals: Phosphor Bronze
O-Rings: Fluorosilicone
Sealing Boot: Silicone Rubber Molded over Thermoplastic Insert

Environmental Ratings

Seal: IP67, Meets IEC 60529 (sealed version only)
Altitude: Tested per MIL-STD 202, Method 105C
Thermal Shock: Meets MIL-STD 202, Method 107G
Operating High Temperature: +85°C, Tested per IEC 68-2-14, Test Na
Operating Low Temperature: -40°C, Tested per IEC 68-2-14, Test Na
Storage High Temperature: +100°C, Tested per IEC 68-2-2, Method Ba
Storage Low Temperature: -55°C, Tested per IEC 68-2-1, Method Aa
Humidity: Meets MIL-STD 202, Method 103B
Humidity, 85/85: 500 hours tested per MIL-STD 202, Method 103B,
Solar Radiation: Tested per MIL-STD 810G, Method 505.5, Procedure II
Chemical Resistance: Meets ISO 16750-5
Dielectric: Meets MIL-STD 202G, Method 301
Insulation Resistance: Tested per MIL-STD 202G, Method 302

EMC Ratings

Radiated Immunity: Meets IEC 61000-4-3
Conducted Immunity: Meets IEC 61000-4-6
Radiated Emissions: Meets ANSI C63.4
Conducted Emissions: Meets EN 55022
Electrostatic Discharge: Meets IEC 61000-4-2
Power Frequency Magnetic Field: Meets IEC 61000-4-8

*Response time is the time from joystick movement to when new X,Y position data is available.

**One cycle is defined as a complete revolution of the shaft around the fixed perimeter, or one actuation in each of the 4 main directions, with return to center between each actuation.

ORDERING INFORMATION

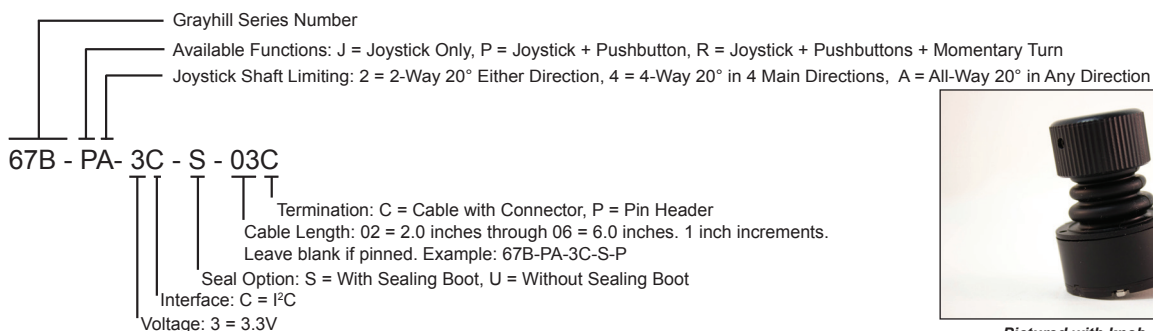

Pictured with knob, p/n: 677702

For prices and custom configurations, contact a local sales office, an authorized distributor, or Grayhill's sales department.



Grayhill, Inc • 561 Hillgrove Avenue • LaGrange, Illinois • 60525-5997 • USA
Phone: 708-354-1040 • Fax: 708-354-2820 • www.grayhill.com

Bulletin 1214 Feb. 2014



Компания «ЭлектроПласт» предлагает заключение долгосрочных отношений при поставках импортных электронных компонентов на взаимовыгодных условиях!

Наши преимущества:

- Оперативные поставки широкого спектра электронных компонентов отечественного и импортного производства напрямую от производителей и с крупнейших мировых складов;
- Поставка более 17-ти миллионов наименований электронных компонентов;
- Поставка сложных, дефицитных, либо снятых с производства позиций;
- Оперативные сроки поставки под заказ (от 5 рабочих дней);
- Экспресс доставка в любую точку России;
- Техническая поддержка проекта, помощь в подборе аналогов, поставка прототипов;
- Система менеджмента качества сертифицирована по Международному стандарту ISO 9001;
- Лицензия ФСБ на осуществление работ с использованием сведений, составляющих государственную тайну;
- Поставка специализированных компонентов (Xilinx, Altera, Analog Devices, Intersil, Interpoint, Microsemi, Aeroflex, Peregrine, Syfer, Eurofarad, Texas Instrument, Miteq, Cobham, E2V, MA-COM, Hittite, Mini-Circuits, General Dynamics и др.);

Помимо этого, одним из направлений компании «ЭлектроПласт» является направление «Источники питания». Мы предлагаем Вам помощь Конструкторского отдела:

- Подбор оптимального решения, техническое обоснование при выборе компонента;
- Подбор аналогов;
- Консультации по применению компонента;
- Поставка образцов и прототипов;
- Техническая поддержка проекта;
- Защита от снятия компонента с производства.



Как с нами связаться

Телефон: 8 (812) 309 58 32 (многоканальный)

Факс: 8 (812) 320-02-42

Электронная почта: org@eplast1.ru

Адрес: 198099, г. Санкт-Петербург, ул. Калинина, дом 2, корпус 4, литера А.