

HEDS-9710, HEDS-9711

Small Optical Encoder Modules

360 lpi Analog Current Output



Data Sheet



Description

The HEDS-971x is a high performance incremental encoder module. When operated in conjunction with either a codewheel or codestrip, this module detects rotary or linear position. The encoder consists of a lensed LED source and a detector IC enclosed in a small C-shaped plastic package. Due to a highly collimated light source and a unique photodetector array, the module is extremely tolerant to mounting misalignment.

The two channel analog outputs and 5 V supply input are accessed through four solder plated leads located on 2.54 mm (0.1 inch) centers.

The standard HEDS-971x is designed for use with an appropriate optical radius codewheel or linear codestrip. Other options are available. Please contact the factory for more information.

Applications

The HEDS-971x provides sophisticated motion detection, making closed loop control, very cost competitive. Typical applications include printers, plotters, copiers and office automation equipment.

Features

- Small size
- Two channel quadrature output
- Linear and rotary applications
- No signal adjustment required
- TTL compatible
- Wave solderable
- Lead free package
- 15°C to 45°C operating temperature
- Single 5 V supply

Block Diagram

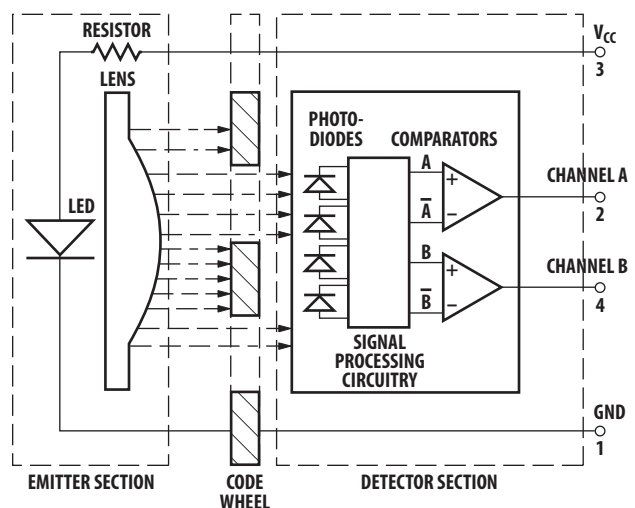

Theory of Operation

An HEDS-971x is a C-shaped emitter/detector module. Coupled with a codewheel, it translates rotary motion into a two-channel digital output, coupled with a codestrip; it translates linear motion into digital outputs.

As seen in the block diagram, the module contains a single Light Emitting Diode (LED) as its light source. The light is collimated into parallel beam by means of a single lens located directly over the LED. Opposite the emitter is the integrated detector circuit. This IC consists of photodetectors and a signal processing circuitry necessary to produce the digital waveforms.

The codewheel/codestrip moves between the emitter and detector, causing the light beam to be interrupted by the pattern of spaces and bars on the codewheel/codestrip. The photodiodes, which detect these interruptions, are arranged in a pattern that corresponds to the radius and count density of the codewheel/codestrip. These photodiodes are also spaced such that a light period on one pair of detectors corresponds to a dark period on the adjacent pairs of detectors. The photodiode outputs are fed through the signal processing circuitry. Two comparators receive these signals and produce the final outputs for Channels A and B. Due to this integrated phasing technique the output of channel A is in quadrature with Channel B (90 degrees out of phase).

Definitions

Count (N): The number of bar and window pairs or counts per revolution (CPR) of the codewheel, or the number of lines per inch of the codestrip (LPI).

1 shaft Rotation = 360 degrees
= N cycles

1 cycle (c) = 360 electrical degrees, equivalent to 1 bar and window pair.

Pulse Width (P): The number of electrical degrees that an output is high during one cycle, nominally 180°e or ½ a cycle.

Pulse Width Error (ΔP): The deviation in electrical degrees of the pulse width from its ideal value of 180°e.

State Width (S): The number of electrical degrees between a transition in the output of channel A and the neighboring transition in the output of channel B. There are 4 states per cycle, each nominally 90°e.

State Width Error (ΔS): The deviation in electrical degrees of each state width from its ideal value of 90°e.

Phase (ϕ): The number of electrical degrees between the center of the high state on channel A and the center of the high state on channel B. This value is nominally 90°e for quadrature output.

Phase Error ($\Delta\phi$): The deviation in electrical degrees of the phase from its ideal value of 90°e.

Direction of Rotation: When the codewheel rotates in the counter-clockwise direction (as viewed from the encoder end of the motor), channel A will lead channel B. If the codewheel rotates in the clockwise direction, channel B will lead channel A.

Optical Radius (R_{op}): The distance from the codewheel's center of rotation to the optical center (O.C) of the encoder module.

Angular Misalignment Error (E_A): Angular misalignment of the sensor in relation to the tangential direction. This applies for both rotary and linear motion.

Mounting Position (R_M): Distance from Motor Shaft center of rotation to center of Alignment Tab receiving hole.

Absolute Maximum Ratings

Parameter	Symbol	Min.	Max.	Units	Notes
Storage Temperature	T_S	-40	85	°C	
Operating Temperature	T_A	0	85	°C	
Supply Voltage	V_{CC}	-0.5	7	Volts	
Soldering Temperature	T_{SOL}		260	°C	$t \leq 5 \text{ sec}$

Recommended Operating Conditions

Parameter	Symbol	Min.	Typ.	Max.	Units	Notes
Temperature	T_A	15		45	°C	
Supply Voltage	V_{CC}	4.8	5.0	5.2	Volts	Ripple < 100 mVp-p
Count Frequency	f			40	kHz	Velocity (rpm) x N/60

Electrical Characteristics

Electrical Characteristics Over the Recommended Operating Conditions. Typical Values at 25°C.

Parameter	Symbol	Min.	Typ.	Max.	Units	Notes
Supply Current	I_{CC}		17	40	mA	

Waveform Definition

ANALOG

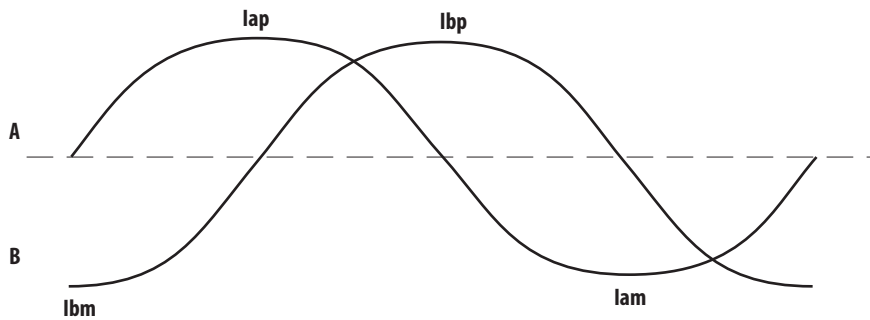

DIGITAL

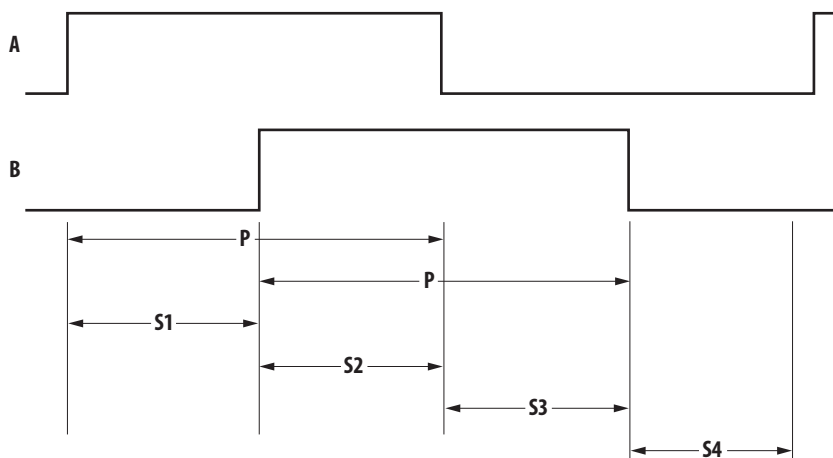

Test Parameter Definitions

Parameter	Symbol	Definition	Units
Ip	Analog peak	The absolute value in μA of the magnitude of the analog signal (i.e. one sided rating).	Iap, Ibp, Iam, Ibm
Ipp	Analog peak to peak	The peak to peak signal magnitude in mA of the analog signal.	Iapp, Ibpp
Iapp/Ibpp	Analog peak to peak ratio	The ratio of A channel peak analog signal to B channel peak to peak analog signal.	
Ioffset	Analog Offset	The offset in μA from the mid-point of the analog peak to peak signal to zero current.	
State Width	State Width	The number of electrical degrees between a transition in channel A and the neighboring transition in channel B. There are 4 states per cycle, each nominally 90°e . The transitions are determined by where the analog signal crosses the Zero point.	State 1 State 2 State 3 State 4
State Width Error	State Width Error	The deviation in electrical degrees of each state width from its ideal value of 90°e .	
Pulse Width	Pulse Width	The number of electrical degrees that an analog output is greater than zero during one cycle. This value is nominally 180°e or $\frac{1}{2}$ cycle.	
Pulse Width Error	Pulse Width Error	The deviation in electrical degrees of each pulse width from its ideal value of 180°e .	

Encoder Characteristics

Encoding Characteristics Over the Recommended Operating Conditions and Mounting Conditions.

These characteristics do not include codewheel/codestrip contribution. The typical values are average over the full rotation of the codewheel.

Parameter	Units	Min.	Max.
State Width Error	°e	-40	40
Phase Error	°e	-40	40
I _{pp}	μA	25	95
I _{ppA} /I _{ppB}	-	0.93	1.16
I _{offset}	μA	-7	7
Linearity Error	-	0	12
Crossing (avg)	μA	9	35

Mounting Considerations

Parameter	Units	Tolerance
Radial	microns	± 200
Tangential	microns	± 400
Gap	microns	50 – 460
O.R.	mm	20.2
CPR	Count	1800

Mounting Consideration

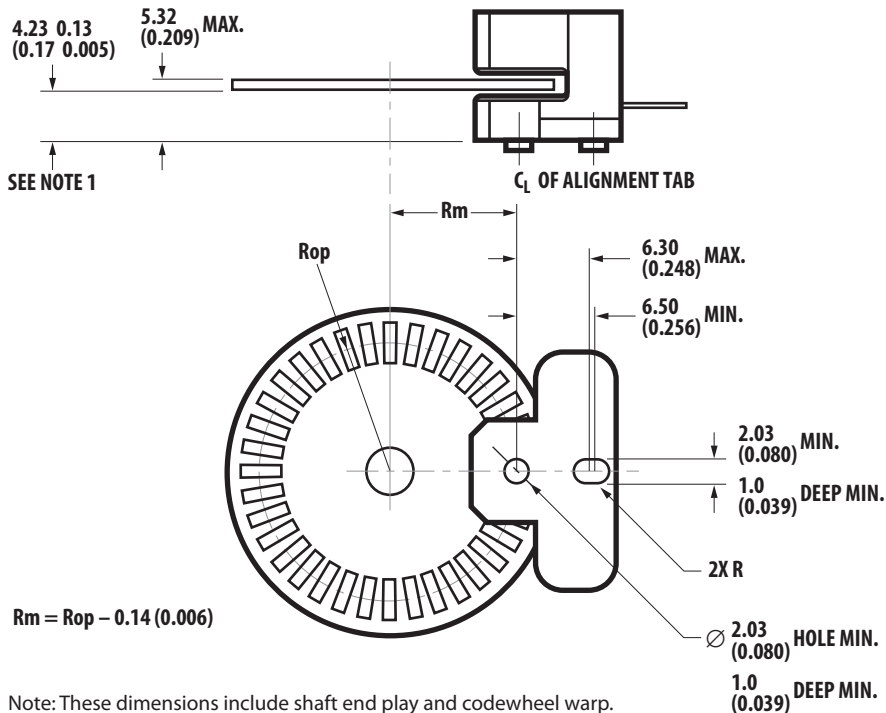

Note: These dimensions include shaft end play and codewheel warp.

All dimensions for mounting the module/codestrip should be measured with respect to the two mounting posts, shown above.

Dimensions in millimeters (inches).

Recommended Codewheel and Codestrip Characteristics

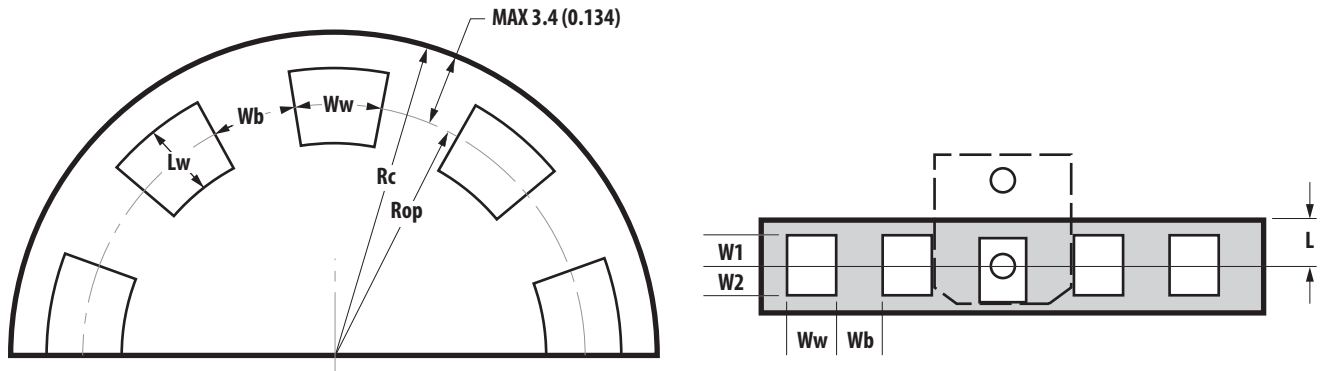

Parameter	Symbol	Min.	Max.	Units	Notes
Window/Bar Ratio	Ww/Wb	0.9	1.1		
Window Length (Rotary)	Lw	1.80 (0.071)	2.30 (0.091)	mm (inch)	
Absolute Maximum Codewheel Radius (Rotary)	Rc		Rop + 3.40 (Rop + 0.134)	mm (inch)	Includes eccentricity errors
Center of Post to Inside Edge of Window	W1	1.04 (0.041)		mm (inch)	
Center of Post to Outside Edge of Window	W2	0.76 (0.030)		mm (inch)	
Center of Post to Inside Edge of Codestrip	L		3.60 (0.142)	mm (inch)	

Analog Encoder Interface Circuit

The circuit shown can be used to convert the current to voltage output. Resistor value R1 and Capacitor C are specified to attain required gain and low pass filtering which are application specific. The gain is chosen to attain maximum output swing and not clamping the op-amp. V_{REF} should be set to $1.4V \pm 0.2V$. A $0.1 \mu F$ bypass capacitor is recommended to be placed within 1 cm of the encoder for optional power supply noise rejection. Output are high impedance (typical 1M Ohm) and susceptible to EMI.

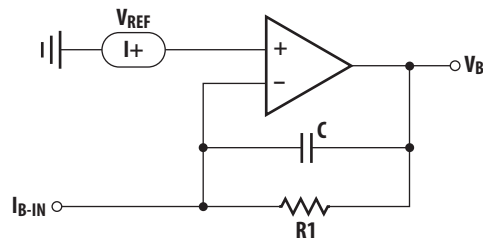
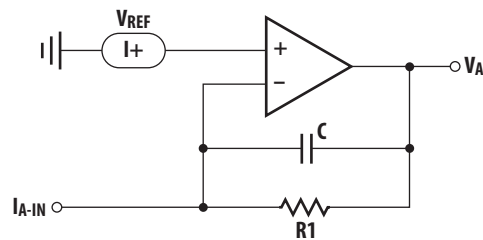

$V_{REF} = 1.4V \pm 0.2V (DC)$

Ordering Information

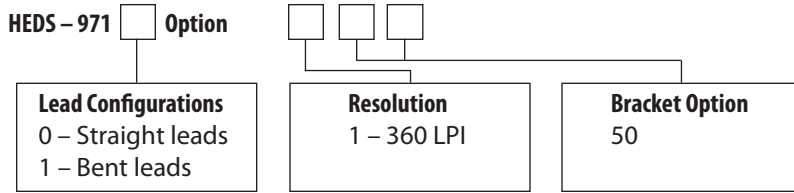

Package Dimensions

Option 50

LEAD THICKNESS = 0.25 mm
LEAD PITCH = 2.54 mm

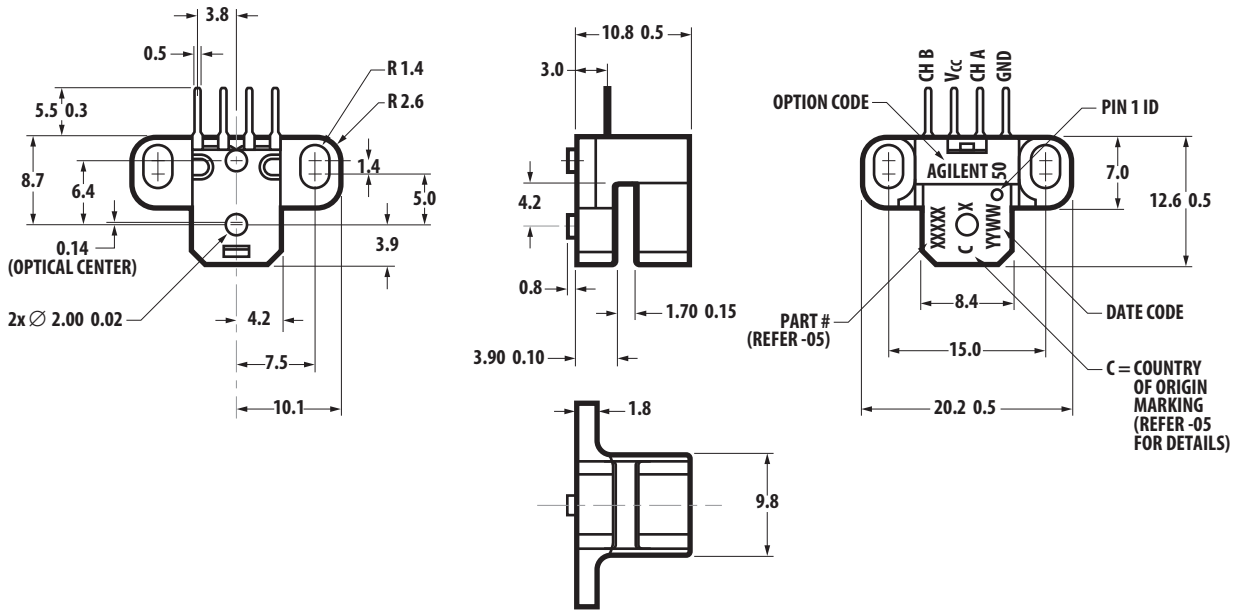

Bent Version - Option 50

LEAD THICKNESS = 0.25 mm
LEAD PITCH = 2.54 mm

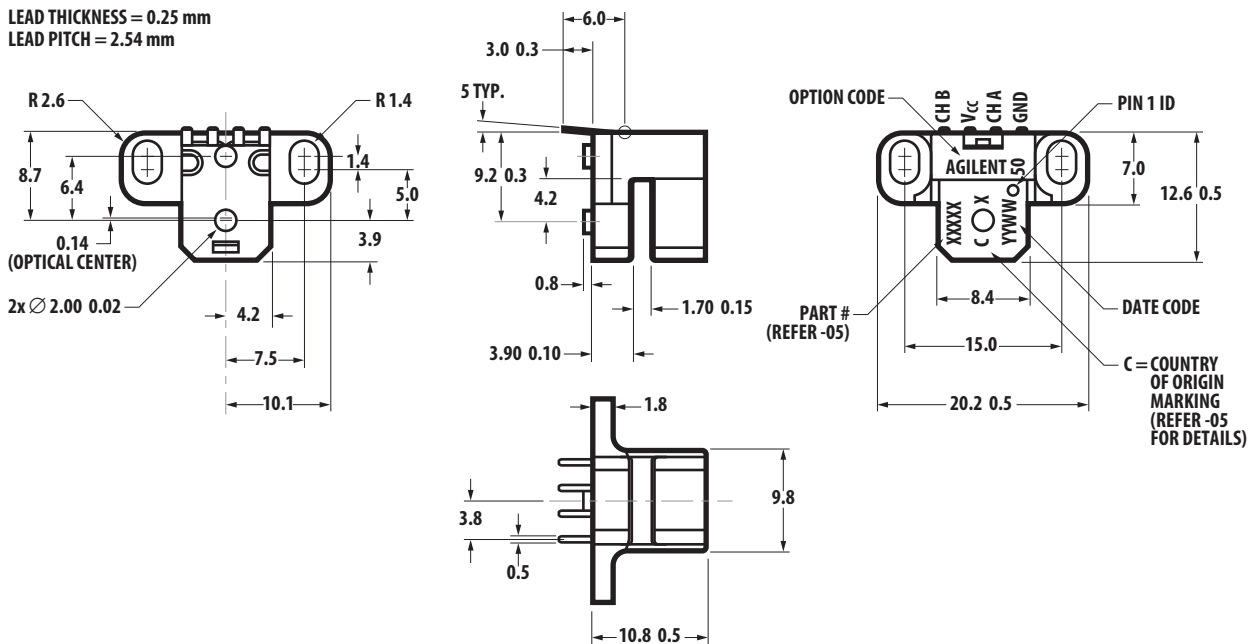

Wave Soldering Profile

Pb-Free Wave Soldering Profile
Std-Profile

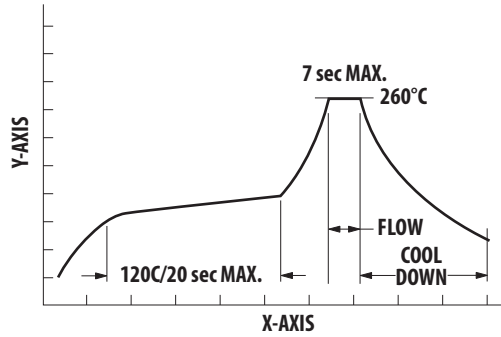

Parameter	Min.	Max.	Nominal Values	Units
A Solder Pot Temperature	NA	260	250 – 260	°C
B Preheat Zone Temperature	85	120	100 – 120	°C
C Dip in Time	5	7	5	sec
D Solder Pot Zone (PCB Top)	NA	NA	NA	°C
E Solder Pot Zone (Encoder Lead)	200	NA	≥ 200	°C

For product information and a complete list of distributors, please go to our web site: www.avagotech.com

Avago, Avago Technologies, and the A logo are trademarks of Avago Technologies in the United States and other countries. Data subject to change. Copyright © 2005-2012 Avago Technologies. All rights reserved. Obsoletes 5989-0702EN AV02-3652EN - June 21, 2012

AVAGO
TECHNOLOGIES



Компания «ЭлектроПласт» предлагает заключение долгосрочных отношений при поставках импортных электронных компонентов на взаимовыгодных условиях!

Наши преимущества:

- Оперативные поставки широкого спектра электронных компонентов отечественного и импортного производства напрямую от производителей и с крупнейших мировых складов;
- Поставка более 17-ти миллионов наименований электронных компонентов;
- Поставка сложных, дефицитных, либо снятых с производства позиций;
- Оперативные сроки поставки под заказ (от 5 рабочих дней);
- Экспресс доставка в любую точку России;
- Техническая поддержка проекта, помощь в подборе аналогов, поставка прототипов;
- Система менеджмента качества сертифицирована по Международному стандарту ISO 9001;
- Лицензия ФСБ на осуществление работ с использованием сведений, составляющих государственную тайну;
- Поставка специализированных компонентов (Xilinx, Altera, Analog Devices, Intersil, Interpoint, Microsemi, Aeroflex, Peregrine, Syfer, Eurofarad, Texas Instrument, Miteq, Cobham, E2V, MA-COM, Hittite, Mini-Circuits, General Dynamics и др.);

Помимо этого, одним из направлений компании «ЭлектроПласт» является направление «Источники питания». Мы предлагаем Вам помощь Конструкторского отдела:

- Подбор оптимального решения, техническое обоснование при выборе компонента;
- Подбор аналогов;
- Консультации по применению компонента;
- Поставка образцов и прототипов;
- Техническая поддержка проекта;
- Защита от снятия компонента с производства.



Как с нами связаться

Телефон: 8 (812) 309 58 32 (многоканальный)

Факс: 8 (812) 320-02-42

Электронная почта: org@eplast1.ru

Адрес: 198099, г. Санкт-Петербург, ул. Калинина, дом 2, корпус 4, литера А.