

MINIATURE ADJUSTABLE HAND CRIMP TOOL MH992

DMC DANIELS
MANUFACTURING
CORPORATION

DATASHEET

THIS HAND TOOL MUST NOT BE USED IN ANY POWERED "PRESS" AS DEFINED BY OSHA CFR 1910.211 (46)

SEE REVERSE SIDE FOR IMPORTANT INFORMATION CONCERNING LIMITED WARRANTY, AND LIMITATION OF LIABILITY.

HOW TO USE THE DANIELS MH992 HAND CRIMP TOOL AND RELATED POSITIONERS

GENERAL INSTRUCTIONS

1. Designation MH992 refers to basic tool without positioners.
2. The tool has a double acting ratchet. Note that tool cannot be opened without completing cycle.

SETTING UP INSTRUCTIONS

1. Tool must be in open position.
2. Remove safety clip from positioner guide.
3. Select positioner for contact to be crimped.
4. Insert positioner into tool positioner guide and turn 90 degrees until bayonet pins lock.
5. Install safety clip into positioner guide (optional).
6. Wire size and corresponding selector number are shown on dataplate.
7. With tool still in the open position, raise and rotate selector knob until number indicated on dataplate for wire size to be crimped is in line with Sel. No. arrow.

CRIMPING INSTRUCTIONS

1. Insert contact and prepared wire through indenter opening and into positioner.
2. Squeeze handles together until ratchet releases. Handle will return to open position. Remove crimped contact and wire.

REMOVING POSITIONER

1. Remove safety clip and reverse procedure described in step four (4) above.

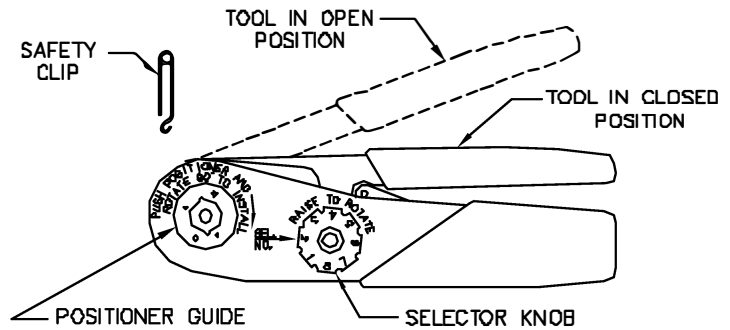

GAGE PART NO.	GO DIA	NO-GO DIA	CRIMP TOOL	SELECTOR NO.
G822	.0305	.0330	MH992	8

ONLY ONE GAGE NECESSARY FOR PERIODIC IN-SERVICE INSPECTION

GAGING INSTRUCTIONS

"GO" GAGING

Operate tool to fully closed position. Insert "GO" gage end as shown. Gage must pass freely between indenter tips.

"NO-GO" GAGING

Operate tool to fully closed position. Maintain firm hand pressure on the tool handles. Insert "NO-GO" gage may partially enter the indenter opening, but must not pass completely through the opening.

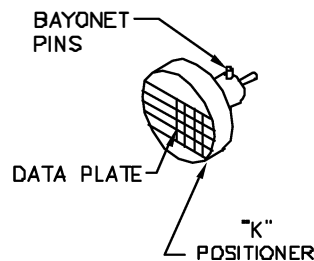
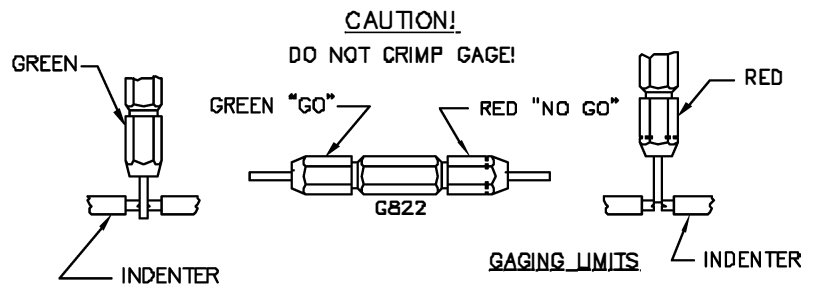

SELECTOR NO.	GAGE-INSPECTION	
	A ±.0001 GO DIA	B ±.0001 NO-GO DIA
1	.0070	.0090
2	.0095	.0115
3	.0120	.0140
4	.0150	.0170
5	.0180	.0200
6	.0225	.0250
7	.0260	.0285
8	.0305	.0330

DANIELS MANUFACTURING CORP., 526 THORPE ROAD, ORLANDO, FL 32824, USA, PHONE 407/855-6161, FAX 407/855-6884.
COPYRIGHT © 1998 DANIELS MANUFACTURING CORP., USA. WWW.DMCTOOLS.COM E-MAIL: DMC@DMCTOOLS.COM ALL RIGHTS RESERVED

CARE OF TOOL

There is virtually no maintenance required. However, it is a good practice to keep indenter tips free of residual color band deposits and other debris. A small wire brush may be used for this purpose.

We strongly recommend that you:

1. DO NOT immerse tool in cleaning solution.
2. DO NOT spray oil into tool to lubricate.
3. DO NOT attempt to disassemble tool or make repairs.

This is a precision hand crimp tool and should be handled as such.

DMC offers complete refurbishing and recalibration services.

DMC specially engineers and manufactures complete tool kits to satisfy individual customer requirements, such as total aircraft support, general shop maintenance or production, on board ship and vehicle service, etc.

LIMITATION OF LIABILITY

DANIELS MANUFACTURING CORPORATION IS NOT LIABLE FOR CONSEQUENTIAL OR SPECIAL DAMAGES OF ANY NATURE OR KIND RESULTING FROM THE USE, OR MISUSE, OF ANY OF ITS PRODUCTS. OWNERS AND USERS OF DMC PRODUCTS ASSUME FULL RESPONSIBILITY FOR INSTRUCTING THEIR EMPLOYEES IN THE PROPER AND SAFE USE OF SUCH PRODUCTS.

LIMITED WARRANTY

DMC (Daniels Manufacturing Corporation) warrants each new product sold by it to be free from defects in material and workmanship under normal use and service. DMC's obligation under this warranty is limited to the free correction or, at DMC's option, the refund of the purchase price of any such product which proves defective in normal service within ninety (90) days after delivery to the first user, provided that the product is returned to DMC with all transportation charges prepaid and which shall appear to DMC's satisfaction, after DMC's inspection, to have been defective in material or workmanship, it being understood that DMC products are not consumer products. This warranty shall not cover any damage to any product which, in the opinion of DMC, was caused by normal wear, misuse, improper operation, tampering, neglect or accident. This warranty is in lieu of all other warranties express or implied. No warranty, express or implied, is made or authorized to be made or assumed with respect to products of Daniels Manufacturing Corporation other than those herein set forth.



Компания «ЭлектроПласт» предлагает заключение долгосрочных отношений при поставках импортных электронных компонентов на взаимовыгодных условиях!

Наши преимущества:

- Оперативные поставки широкого спектра электронных компонентов отечественного и импортного производства напрямую от производителей и с крупнейших мировых складов;
- Поставка более 17-ти миллионов наименований электронных компонентов;
- Поставка сложных, дефицитных, либо снятых с производства позиций;
- Оперативные сроки поставки под заказ (от 5 рабочих дней);
- Экспресс доставка в любую точку России;
- Техническая поддержка проекта, помощь в подборе аналогов, поставка прототипов;
- Система менеджмента качества сертифицирована по Международному стандарту ISO 9001;
- Лицензия ФСБ на осуществление работ с использованием сведений, составляющих государственную тайну;
- Поставка специализированных компонентов (Xilinx, Altera, Analog Devices, Intersil, Interpoint, Microsemi, Aeroflex, Peregrine, Syfer, Eurofarad, Texas Instrument, Miteq, Cobham, E2V, MA-COM, Hittite, Mini-Circuits, General Dynamics и др.);

Помимо этого, одним из направлений компании «ЭлектроПласт» является направление «Источники питания». Мы предлагаем Вам помощь Конструкторского отдела:

- Подбор оптимального решения, техническое обоснование при выборе компонента;
- Подбор аналогов;
- Консультации по применению компонента;
- Поставка образцов и прототипов;
- Техническая поддержка проекта;
- Защита от снятия компонента с производства.



Как с нами связаться

Телефон: 8 (812) 309 58 32 (многоканальный)

Факс: 8 (812) 320-02-42

Электронная почта: org@eplast1.ru

Адрес: 198099, г. Санкт-Петербург, ул. Калинина, дом 2, корпус 4, литера А.