

MAX14870 Evaluation Kit

Evaluates: MAX14870, MAX14872

General Description

The MAX14870 evaluation kit (EV kit) consists of a MAX14870 evaluation board and software. The EV kit is a fully assembled and tested circuit board that evaluates the MAX14870 full-bridge DC motor driver.

The EV Kit may also be used to evaluate the MAX14872.

The EV kit is designed to work with a PC-based GUI or as a standalone board, demonstrating all the major features of the device. The EV kit includes Windows®-compatible software that provides a graphical user interface (GUI) for exercising the features of the MAX14870. The EV kit is connected to a PC through a USB A-to-micro B cable.

Features

- Operates from a Wide 4.5V to 36V Supply
- Standalone or Software-Controlled Operation
- USB-PC Connection
- Proven PCB Layout
- Fully Assembled and Tested

Ordering Information appears at end of data sheet.

MAX14870 EV Kit Block Diagram

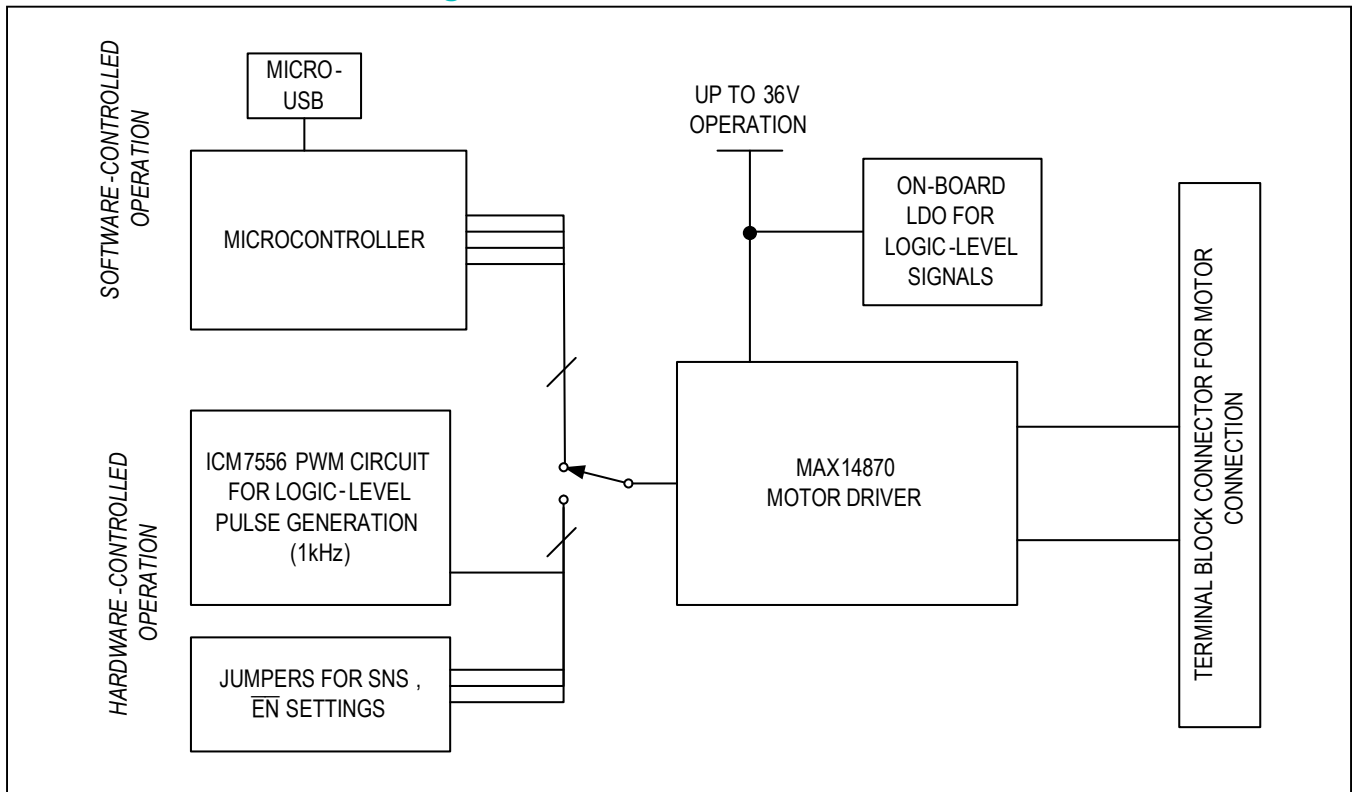

Windows, Windows XP, and Windows Vista are registered trademarks of Microsoft Corp.

Quick Start

Recommended Equipment

- MAX14870 EV kit
- User-supplied Windows XP®, Windows Vista®, or Windows 7 PC with a spare USB port
- 24V, 2A power supply
- DC brushed motor

Procedure

The EV kit is fully assembled and tested. Follow the steps below to verify board operation before exercising the full features of the device:

- 1) Verify that all the jumpers are in their default positions, as shown in [Table 1](#).
- 2) Connect the 24V DC power supply on the VDD and GND connectors on the EV kit board.
- 3) See the application note *Using the MAX14870EVKIT with Software* to configure the board for software operation.
- 4) Connect the DC brushed motor to the M1 and M2 terminals on the P1 connector.
- 5) Turn on the 24V supply.

Detailed Description of Hardware

The MAX14870 EV kit is a fully tested circuit board demonstrating the capabilities of the MAX14870 motor driver. The EV kit is designed to work with a PC-based GUI or as a stand-alone board, demonstrating all of the major features of the device.

Stand-Alone Operation

Remove all of the shunts on the P2 header for stand-alone operation. On-board LDOs generate logic rails and headers are included for device configuration in stand-alone mode.

On-Board LDO

The MAX15006 (U5) on-board LDO generates 3.3V for logic signals and for powering the fault LED. The 3.3V LDO also powers the on-board ICM7556 PWM signal generator.

On-Board PWM Generator

The ICM7556 (U2) general-purpose timer circuit is available to generate PWM signals for switching either the PWM or DIR inputs. Adjust the R1 potentiometer to change the duty cycle of the output signal.

The EV kit comes with the PWM frequency set up 1kHz but can be adjusted up to 10kHz by changing the C3 capacitor. Set the PWM frequency using the following equation:

$$f = 1.46 / [(R_1 + 2 \times R_{32}) \times C_3]$$

Fault Indicator LED

The $\overline{\text{FAULT}}$ output is connected to the 3.3V logic supply through R4. A fault is generated when an overcurrent condition occurs on M1 and/or M2. LED1 turns on during a fault condition.

NOTE: To ensure that LED1 turns on during a short-circuit event, use a power supply capable of supply at least 6A when testing short-circuit functionality.

Table 1. Jumper Descriptions

JUMPER	SHUNT POSITON	DESCRIPTION
J1	1-2	PWM is high
	2-3	PWM is low
J2	1-2	DIR is high
	2-3	DIR is low
J3	1-2	$\overline{\text{EN}}$ is high
	2-3	$\overline{\text{EN}}$ is low
J4	1-2*	SNS is connected to COM
	2-3	SNS is connected to GND
J5	1-2	Output of the ICM7556 circuit is connected to PWM
	2-3	Output of the ICM7556 circuit is connected to DIR
J6	Open*	COM is not shorted to ground
	Closed	COM is shorted to ground
J7	Open*	This jumper is used to program the on-board microcontroller. Do not shunt this jumper.
	Closed	
J8	Open*	This jumper is used to program the on-board microcontroller. Do not shunt this jumper.
	Closed	
J9	Open*	This jumper is used to program the on-board microcontroller. Do not shunt this jumper.
	Closed	
P2	1-2*	$\overline{\text{FAULT}}$ is connected to LED1 circuitry
	3-4*	PWM signal is generated by the on-board microcontroller.
	5-6*	DIR signal is generated by the on-board microcontroller.
	7-8*	$\overline{\text{EN}}$ signal is generated by the on-board microcontroller.

*Default position.

Component Information, PCB Layout, and Schematic

See the following links for component information and schematic:

- [MAX14870 EV BOM](#)
- [MAX14870 PCB Layout](#)
- [MAX14870 EV Schematic](#)

Ordering Information

PART	TYPE
MAX14870EVKIT#	EV Kit

#Denotes RoHS compliant.

Revision History

REVISION NUMBER	REVISION DATE	DESCRIPTION	PAGES CHANGED
0	6/15	Initial release	—

For pricing, delivery, and ordering information, please contact Maxim Direct at 1-888-629-4642, or visit Maxim Integrated's website at www.maximintegrated.com.

Maxim Integrated cannot assume responsibility for use of any circuitry other than circuitry entirely embodied in a Maxim Integrated product. No circuit patent licenses are implied. Maxim Integrated reserves the right to change the circuitry and specifications without notice at any time.

Bill of Materials (BOM)

DATE: 05/14/2015

DESIGN: max14870_evkit_b

ITEM	REF_DES	DNI	QTY	MFG PART #	MANUFACTURER	VALUE	DESCRIPTION
1	C1, C2, C17, C18, C24, C25	-	6	C0603C104K4RAC; GCM188R71C104KA37; C1608X7R1C104K; GRM188R71C104K; C0603X7R160-104KNE	KEMET/MURATA/ DK/VENKEL LTD.	0.1UF	CAPACITOR; SMT (0603); CERAMIC CHIP; 0.1UF; 16V; TOL=10%; TG=-55 DEGC TO +125 DEGC; TC=X7R;
2	C3, C4, C6	-	3	C0603X7R500103JNP; C0603C103J5	KEMET	0.01UF	CAPACITOR; SMT (0603); CERAMIC CHIP; 0.01UF; 50V; TOL=5%; MODEL=X7R; TG=-55 DEGC TO +125 DEGC; TC=+/-
3	C5	-	1	EEU-EB1H331	PANASONIC	330UF	CAPACITOR; THROUGH HOLE-RADIAL LEAD; ALUMINUM- ELECTROLYTIC; 330UF; 50V; TOL=20%; MODEL=EB SERIES; TG=- 40 DEGC TO +105 DEGC
4	C7, C8	-	2	C1206C105K5RAC; GRM31CR71H105KA61;GRM3 1MR71H105KA88	KEMET/MURATA	1UF	CAPACITOR; SMT (1206); CERAMIC CHIP; 1UF; 50V; TOL=10%; TG=-55 DEGC TO +125 DEGC; TC=X7R
5	C9, C14, C16, C22	-	4	C0603C475K8PAC;LMK107BJ4 75KA-T; CGB3B1X5R1A475K;C1608X5 R1A475K080	GENERIC PART	4.7UF	CAPACITOR; SMT (0603); CERAMIC CHIP; 4.7UF; 10V; TOL=10%; TG=-55 DEGC TO +85 DEGC; TC=X5R
6	C10, C13, C15, C19-C21, C23	-	7	GRM188R71E105KA12D; CGA3E1X7R1E105K	MURATA	1UF	CAPACITOR; SMT (0603); CERAMIC CHIP; 1UF; 25V; TOL=10%; MODEL=GRM SERIES; TG=-55 DEGC TO +125 DEGC; TC=X7R
7	C11	-	1	C1608X5R1E225K; TMK107ABJ225KA-T	TDK/TAIYO YUDEN	2.2UF	CAPACITOR; SMT (0603); CERAMIC CHIP; 2.2UF; 25V; TOL=10%; MODEL=; TG=-55 DEGC TO +85 DEGC; TC=X5R
8	C12	-	1	C1608X5R1H104K	TDK	0.1UF	CAPACITOR; SMT (0603); CERAMIC CHIP; 0.1UF; 50V; TOL=10%; MODEL=C SERIES; TG=-55 DEGC TO +85 DEGC; TC=X5R
9	C26, C27	-	2	C0603C0G500-180JNE; C1608C0G1H180J; GRM1885C1H180J	VENKEL LTD./TDK/MURATA	18PF	CAPACITOR; SMT (0603); CERAMIC CHIP; 18PF; 50V; TOL=5%; MODEL=; TG=-55 DEGC TO +125 DEGC; TC=C0G
10	EN, M1, M2, DIR, PWM, SNS, FAULT	-	7	5014	KEYSTONE	N/A	TEST POINT; PIN DIA=0.125IN; TOTAL LENGTH=0.445IN; BOARD HOLE=0.063IN; YELLOW; PHOSPHOR BRONZE WIRE SILVER PLATE FINISH;
11	GND, TP3, TP5, TP9	-	4	5011	KEYSTONE	N/A	TEST POINT; PIN DIA=0.125IN; TOTAL LENGTH=0.445IN; BOARD HOLE=0.063IN; BLACK; PHOSPHOR BRONZE WIRE SILVER PLATE FINISH;
12	J1-J5	-	5	PCC03SAAN	SULLINS	PCC03SAAN	CONNECTOR; MALE; THROUGH HOLE; BREAKAWAY; STRAIGHT THROUGH; 3PINS; -65 DEGC TO +125 DEGC
13	J6	-	1	PCC02SAAN	SULLINS	PCC02SAAN	CONNECTOR; MALE; THROUGH HOLE; BREAKAWAY; STRAIGHT THROUGH; 2PINS; -65 DEGC TO +125 DEGC
14	J7-J9	-	3	PEC02SAAN	SULLINS	PEC02SAAN	CONNECTOR; MALE; THROUGH HOLE; BREAKAWAY; STRAIGHT; 2PINS
15	L1	-	1	BLM21AG601SN1D	MURATA	600	INDUCTOR; SMT (0805); FERRITE-BEAD; 600; TOL=+/-25%; 0.2A
16	LED1-LED3	-	3	597-3111-407F	DIALIGHT	597-3111-407F	DIODE; LED; SMT LED; RED; SMT (1206); PIV=4V; IF=0.03A
17	LED4	-	1	597-3311-407F	DIALIGHT	597-3311-407F	DIODE; LED; STANDARD; GREEN; SMT (1206); PIV=2.1V; IF=0.02A
18	P1	-	1	1935200	PHOENIX CONTACT	1935200	CONNECTOR; FEMALE; THROUGH HOLE; GREEN TERMINAL BLOCK; STRAIGHT; 6PINS
19	P2	-	1	PEC04DAAN	SULLINS ELECTRONICS CORP.	PEC04DAAN	CONNECTOR; MALE; THROUGH HOLE; BREAKAWAY; STRAIGHT; 8PINS

20	P3	-	1	10118193-0001LF	FCI CONNECT	10118193-0001LF	CONNECTOR; FEMALE; SMT; MICRO USB B TYPE RECEPTACLE; RIGHT ANGLE; 5PINS
21	Q2, Q3	-	2	MMBT3904	N/A	MMBT3904	TRANSISTOR, NPN, SOT-23, PD=0.225W, IC=0.2A, VCEO=40V
22	R1	-	1	CRCW0603120KFK	VISHAY DALE	120K	RESISTOR, 0603, 120K OHM, 1%, 100PPM, 0.10W, THICK FILM
23	R2	-	1	PVZ3A103C01	MURATA	10K	RESISTOR; SMT J-LEAD; TRIMMER POTENTIOMETER; 1 TURN; 10K OHM; 30%; 500PPM; 0.1W; TADJ; CARBON FILM
24	R3, R5, R16-R18, R22, R23	-	7	CHPHT0603K1002FGT	VISHAY SFERNICE	10K	RESISTOR; 0603; 10K OHM; 1%; 100PPM; 0.0125W; THICK FILM
25	R4	-	1	RC1608J000CS; CR0603-J-000ELF; RC0603JR-070RL	SAMSUNG ELECTRONICS/BOURNS/YAGEO PH	0	RESISTOR; 0603; 0 OHM; 5%; JUMPER; 0.10W; THICK FILM
26	R6	-	1	CRCW06036K04FK	VISHAY DALE	6.04K	RESISTOR; 0603; 6.04K; 1%; 100PPM; 0.10W; THICK FILM
27	R7	-	1	CRA2512-FZ-R100ELF	BOURNS	0.1	RESISTOR; 2512; 0.1 OHM; 1%; 75PPM; 3W; METAL FILM
28	R10	-	1	CRCW0805270RFK	VISHAY DALE	270	RESISTOR, 0805, 270 OHM, 1%, 100PPM, 0.125W, THICK FILM
29	R11	-	1	TNPW06033K92BE	VISHAY DALE	3.92K	RESISTOR, 0603, 3.92K OHM, 0.1%, 25PPM, 0.10W, THICK FILM
30	R12	-	1	CRCW06033922FK	VISHAY DALE	39.2K	RESISTOR; 0603; 39.2K; 1%; 100PPM; 0.10W; THICK FILM
31	R13	-	1	CRCW0603332RFK; ERJ-3EKF3320	VISHAY DALE/PANASONIC	332	RESISTOR; 0603; 332 OHM; 1%; 100PPM; 0.10W; THICK FILM
32	R14	-	1	CRCW0603102KFK	VISHAY DALE	102K	RESISTOR; 0603; 102K OHM; 1%; 100PPM; 0.10W; THICK FILM
33	R15	-	1	CRCW06031K50FK	VISHAY DALE	1.5K	RESISTOR; 0603; 1.5K; 1%; 100PPM; 0.10W; THICK FILM
34	R19, R20	-	2	MCR10EZHF1370	ROHM	137	RESISTOR; 0805; 137 OHM; 1%; 100PPM; 0.125W; THICK FILM
35	R21	-	1	CR0603-FX-1001ELF	BOURNS	1K	RESISTOR; 0603; 1K OHM; 1%; 100PPM; 0.10W; THICK FILM
36	R32	-	1	CRCW060313K0FK; ERJ-3EKF1302V	VISHAY DALE/PANASONIC	13K	RESISTOR, 0603, 13KOHMS, 1%, 100PPM, 0.1W, THICK FILM
37	RP	-	1	EXB-28V102JX	PANASONIC	1K	RESISTOR; ARRAY; 0402; 1K OHM; 5%; 200PPM; 0.063W; THICK FILM
38	SU1-SU7	-	7	STC02SYAN	SULLINS ELECTRONICS CORP.	STC02SYAN	TEST POINT; JUMPER; STR; TOTAL LENGTH=0.256IN; BLACK; INSULATION=PBT CONTACT=PHOSPHOR BRONZE; COPPER PLATED TIN OVERALL
39	U1	-	1	ICM7556ISD+	MAXIM	ICM7556ISD+	IC; TIMR; GENERAL PURPOSE TIMER; NSOIC14 150MIL
40	U3	-	1	MAX14870ETC+	MAXIM	MAX14870ETC+	IC; DRV; FULL-BRIDGE DC MOTOR DRIVER; TDFN12-EP 3X3
41	U4	-	1	MAX8880ETT+	MAXIM	MAX8880ETT+	IC; VREG; 12V; ULTRA-LOW-IC; LOW-DROPOUT LINEAR REGULATOR WITH POK; TDFN6-EP 3X3
42	U5	-	1	MAX15006AATT+	MAXIM	MAX15006AATT+	IC; VREG; ULTRA-LOW QUIESCENT-CURRENT LINEAR REGULATOR; TDFN6-EP 3X3
43	U6	-	1	FT232RL	FUTURE TECHNOLOGY DEVICES INTL LTD.	FT232RL	IC; INFC; USB UART INTERFACE; SSOP28
44	U7	-	1	STM32F103RET6	ST MICROELECTRONICS	STM32F103RET6	IC; MMR; HIGH-DENSITY PERFORMANCE LINE ARM-BASED 32-BIT MCU WITH 512KB FLASH; 11 TIMERS; 3 ADC; 13 COMMUNICATION INTERFACE; LOFP64 10X10

45	U8	-	1	MAX14585AEVB+	MAXIM	MAX14585AEVB+	IC: ASW; HI-SPEED USB AND AUDIO SWITCHES WITH NEGATIVE SIGNAL CAPABILITY AND HIGH-VOLATGE-TOLERABLE VBUS DETECTION; UTQFN10 1.4X1.8
46	U11	-	1	NC7SZ125M5X	FAIRCHILD SEMICONDUCTOR	NC7SZ125M5X	IIC; BUF; TINYLOGIC UHS BUFFER WITH THREE-STATE OUTPUT; SOT23-5
47	VDD	-	1	5010	KEYSTONE	N/A	TESTPOINT WITH 1.80MM HOLE DIA, RED, MULTIPURPOSE;
48	Y1	-	1	HCM49-8.000MABJ-UT	CITIZEN	8MHZ	CRYSTAL; SMT ; AT-CUT CRYSTAL UNIT; 18PF; 8MHZ; +/-30PPM; +/-30PPM
49	P4	DNP	1	PEC10SAAN	SULLINS ELECTRONICS CORP.	PEC10SAAN	CONNECTOR: MALE; THROUGH HOLE; BREAKAWAY; STRAIGHT; 10PINS
50	P6, P8, P11-P13, PC0, PC1, PC6, PC7	DNP	9	PEC01SAAN	SULLINS ELECTRONICS CORP	PEC01SAAN	CONNECTOR: MALE; THROUGH HOLE; BREAKAWAY; STRAIGHT; 1PIN
TOTAL			107				

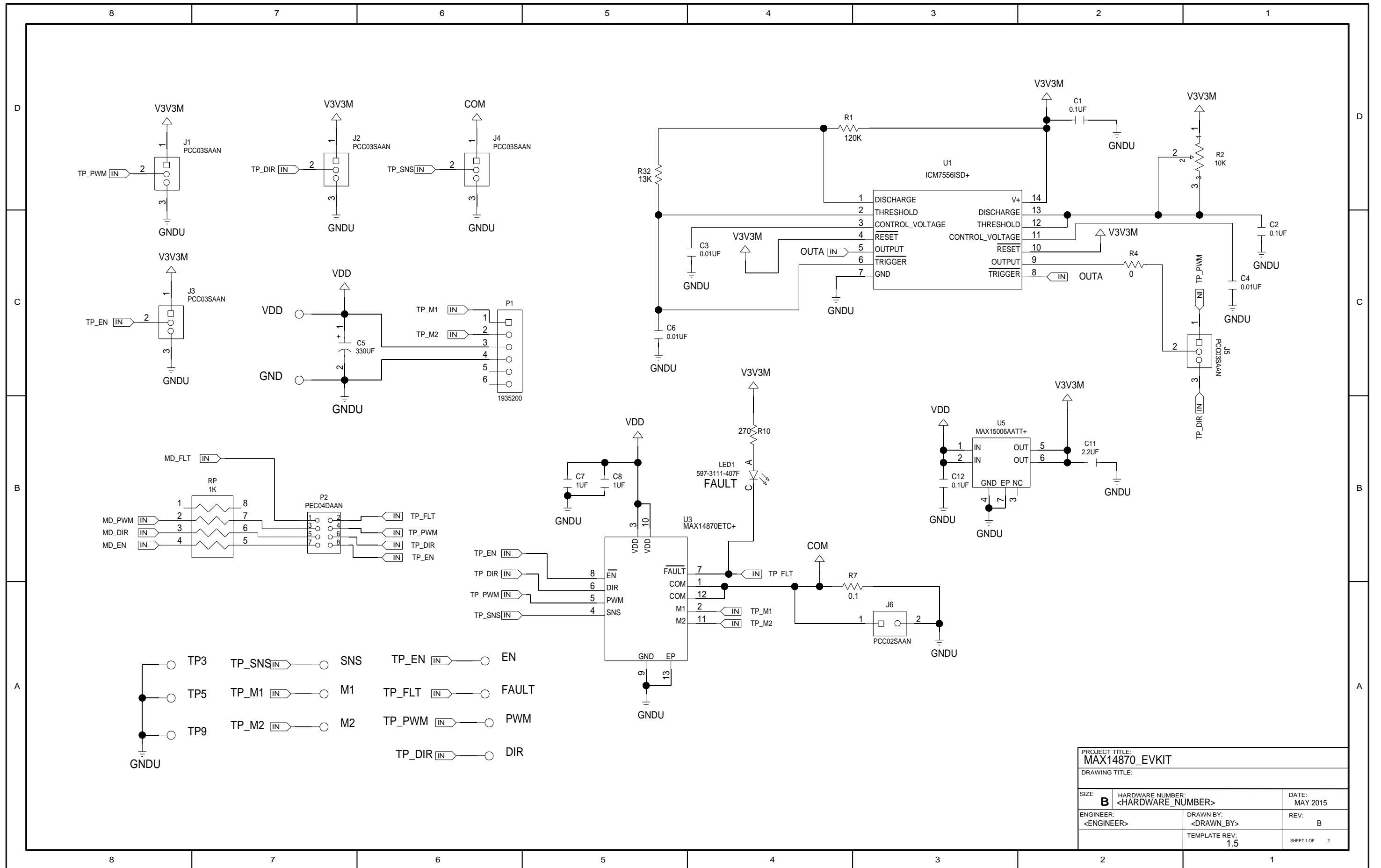

PROJECT TITLE: MAX14870_EVKIT		
DRAWING TITLE:		
SIZE B	HARDWARE NUMBER: <HARDWARE_NUMBER>	DATE: MAY 2015
ENGINEER: <ENGINEER>	DRAWN BY: <DRAWN_BY>	REV: B
	TEMPLATE REV: 1.5	SHEET 1 OF 2

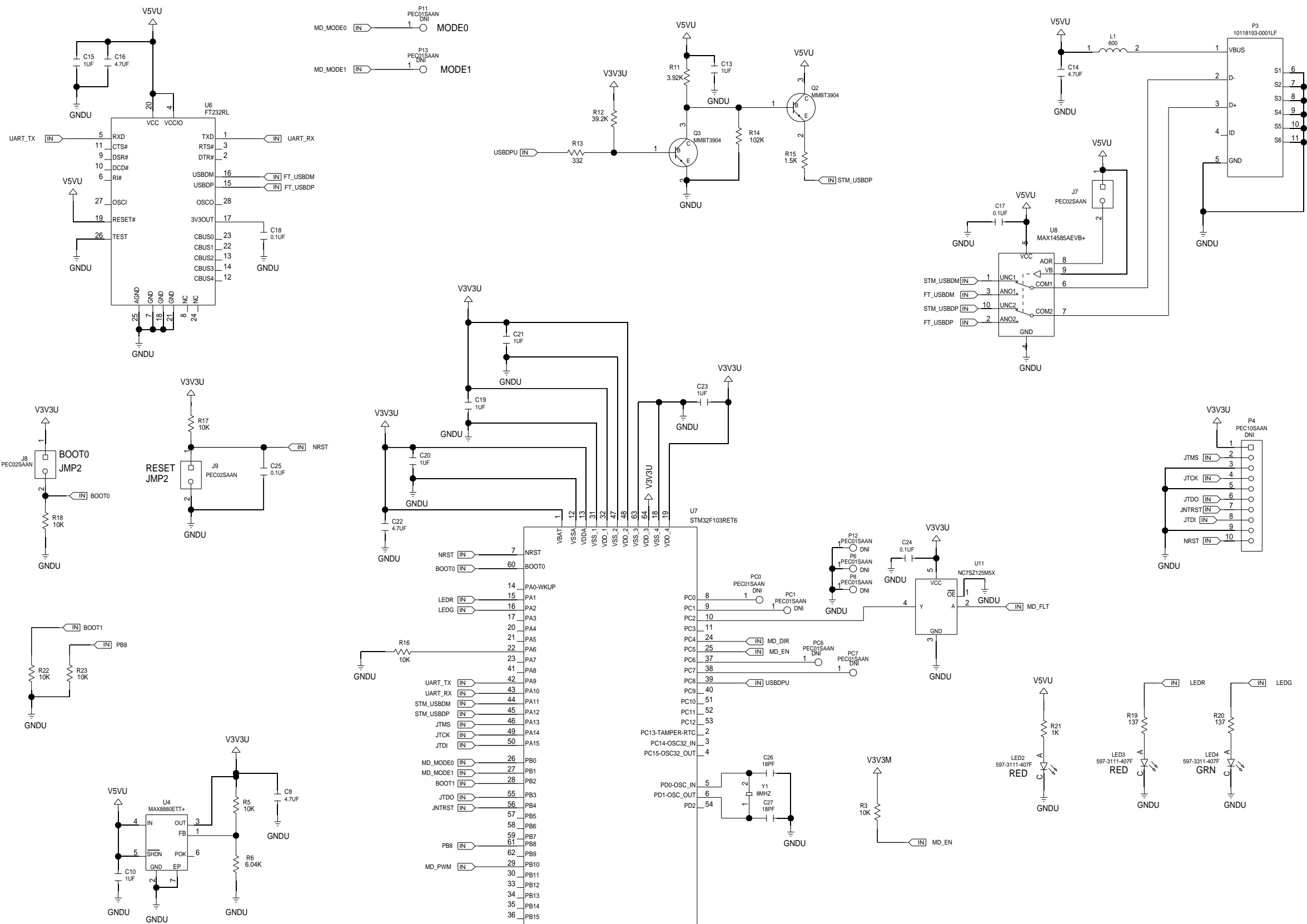

PROJECT TITLE:		
MAX14870_EVKIT		
DRAWING TITLE:		
SIZE:	HARDWARE NUMBER:	DATE:
	<HARDWARE_NUMBER>	MAY 2015
ENGINEER:	DRAWN BY:	REV.:
<ENGINEER>	<DRAWN_BY>	B
	TEMPLATE REV.:	SHEET 2 OF
	1.5	2



This document contains information considered proprietary, and shall not be reproduced wholly or in part, nor disclosed to others without specific written permission.

HARDWARE NAME: MAX14870_EVKIT_B

HARDWARE NUMBER:

ENGINEER:

DESIGNER:

DATE: 05/14/2015

ODB+ / GERBER: SILK_TOP

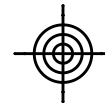
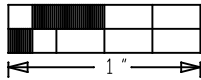
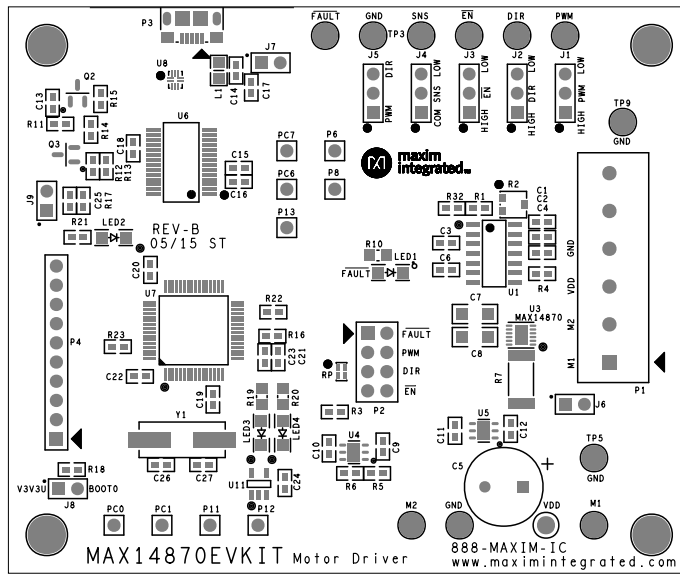
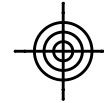



This document contains information considered proprietary, and shall not be reproduced wholly or in part, nor disclosed to others without specific written permission.

HARDWARE NAME: MAX14870_EVKIT_B

HARDWARE NUMBER:

ENGINEER: DESIGNER:

DATE: 05/14/2015

ODB++/GERBER: TOP

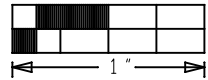
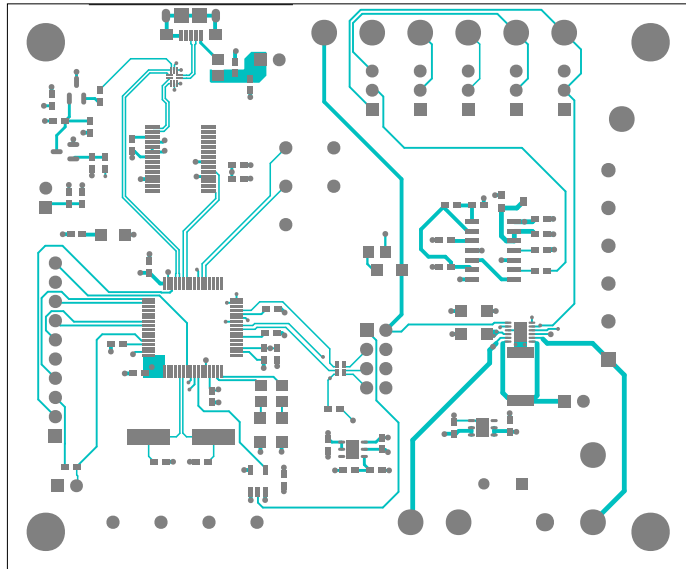
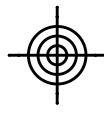
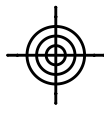



This document contains information considered proprietary, and shall not be reproduced wholly or in part, nor disclosed to others without specific written permission.

HARDWARE NAME: MAX14870_EVKIT_B

HARDWARE NUMBER:

ENGINEER: DESIGNER:

DATE: 05/14/2015

ODB++/GERBER: LAYER 2

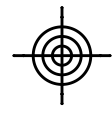
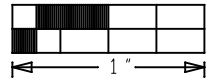
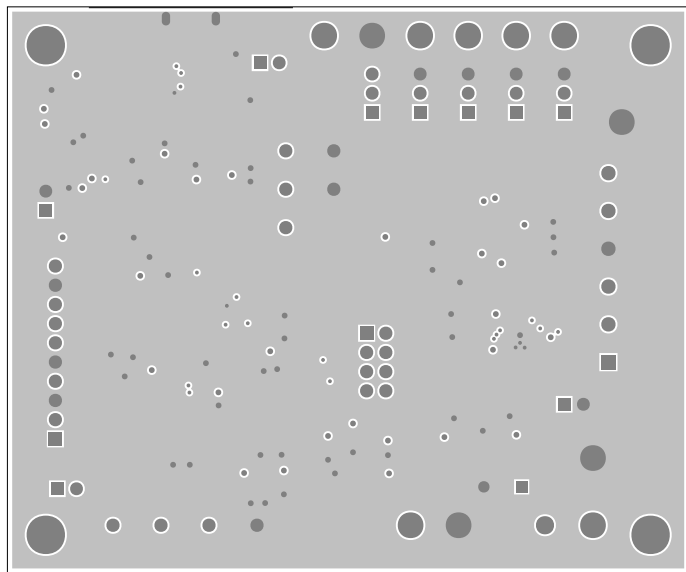
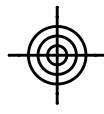
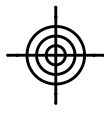



This document contains information considered proprietary, and shall not be reproduced wholly or in part, nor disclosed to others without specific written permission.

HARDWARE NAME: MAX14870_EVKIT_B

HARDWARE NUMBER:

ENGINEER: DESIGNER:

DATE: 05/14/2015

ODB++/GERBER: LAYER 3

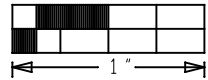
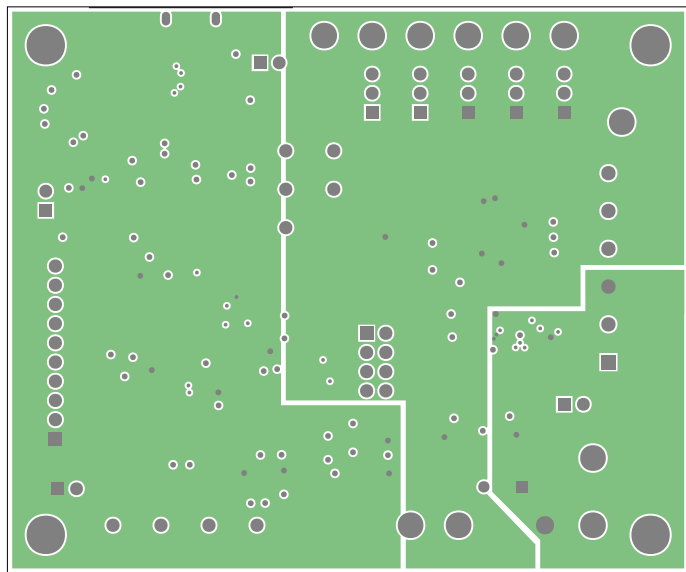
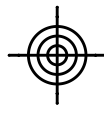
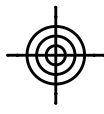



This document contains information considered proprietary, and shall not be reproduced wholly or in part, nor disclosed to others without specific written permission.

HARDWARE NAME: MAX14870_EVKIT_B

HARDWARE NUMBER:

ENGINEER: DESIGNER:

DATE: 05/14/2015

ODB++/GERBER: BOTTOM

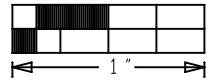
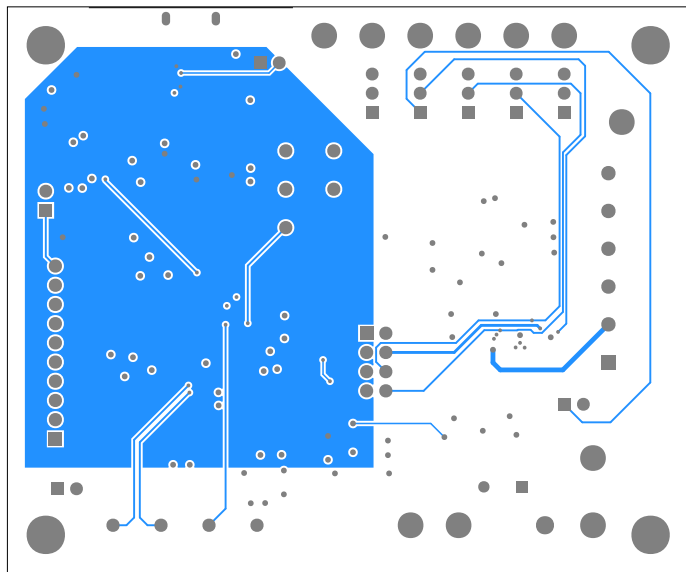
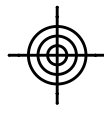
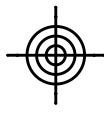



Компания «ЭлектроПласт» предлагает заключение долгосрочных отношений при поставках импортных электронных компонентов на взаимовыгодных условиях!

Наши преимущества:

- Оперативные поставки широкого спектра электронных компонентов отечественного и импортного производства напрямую от производителей и с крупнейших мировых складов;
- Поставка более 17-ти миллионов наименований электронных компонентов;
- Поставка сложных, дефицитных, либо снятых с производства позиций;
- Оперативные сроки поставки под заказ (от 5 рабочих дней);
- Экспресс доставка в любую точку России;
- Техническая поддержка проекта, помощь в подборе аналогов, поставка прототипов;
- Система менеджмента качества сертифицирована по Международному стандарту ISO 9001;
- Лицензия ФСБ на осуществление работ с использованием сведений, составляющих государственную тайну;
- Поставка специализированных компонентов (Xilinx, Altera, Analog Devices, Intersil, Interpoint, Microsemi, Aeroflex, Peregrine, Syfer, Eurofarad, Texas Instrument, Miteq, Cobham, E2V, MA-COM, Hittite, Mini-Circuits, General Dynamics и др.);

Помимо этого, одним из направлений компании «ЭлектроПласт» является направление «Источники питания». Мы предлагаем Вам помощь Конструкторского отдела:

- Подбор оптимального решения, техническое обоснование при выборе компонента;
- Подбор аналогов;
- Консультации по применению компонента;
- Поставка образцов и прототипов;
- Техническая поддержка проекта;
- Защита от снятия компонента с производства.



Как с нами связаться

Телефон: 8 (812) 309 58 32 (многоканальный)

Факс: 8 (812) 320-02-42

Электронная почта: org@eplast1.ru

Адрес: 198099, г. Санкт-Петербург, ул. Калинина, дом 2, корпус 4, литера А.