

CKT. SIZE	DIM. A	DIM. B
4	2.00	4.00
6	4.00	6.00
8	6.00	8.00
10	8.00	10.00
12	10.00	12.00
14	12.00	14.00
16	14.00	16.00
18	16.00	18.00
20	18.00	20.00
22	20.00	22.00
24	22.00	24.00
26	24.00	26.00
28	26.00	28.00
30	28.00	30.00
32	30.00	32.00
34	32.00	34.00
36	34.00	36.00
38	36.00	38.00
40	38.00	40.00
42	40.00	42.00
44	42.00	44.00

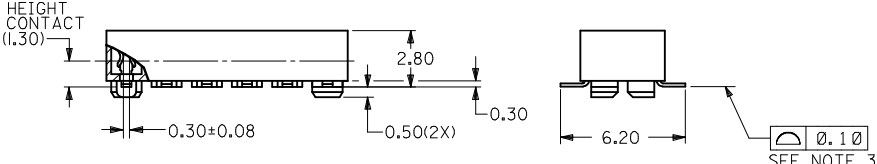

PART NO. LEGEND

87263 - * * * *

CIRCUIT SIZE

PLATING OPTION
 3 - 0.38um MIN. GOLD
 5 - 0.76um MIN. GOLD
 6 - (0.13-0.38)um GOLD FLASH

PACKAGING
 0 - W/CAP IN TUBE (SEE SHEET 2)
 2 - W/O CAP IN TUBE (SEE SHEET 2)
 8 - W/O CAP IN TAPE & REEL (SEE SHEET 3)
 9 - W/CAP IN TAPE & REEL (SEE SHEET 3)

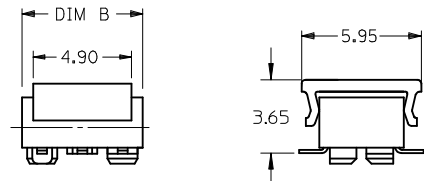
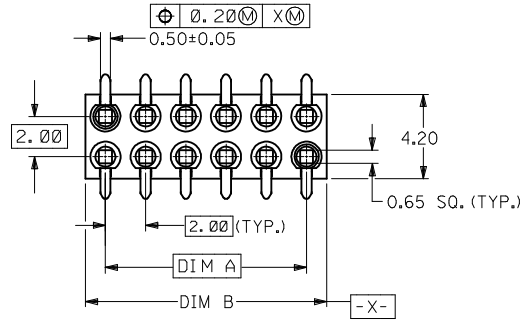

PARTS TO BE PACK WITH CAP (12 CKT SHOWN)

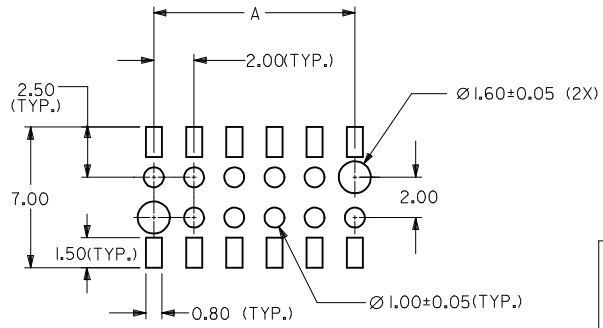

RECOMMENDED SOLDER PAD DESIGN

NOTES:

- FOR ILLUSTRATION PURPOSES, DRAWING SHOWS PART WITH 12 CIRCUIT SIZE.
- PLATING
 POST-PLATING - SELECTIVE GOLD (SEE LEGEND) AT CONTACT AREA, AND 1.27um MIN. SELECTIVE TIN AT SOLDER AREA BOTH OVER 1.27um MIN. NICKEL OVERALL.
- CO-PLANARITY OF P.C TAIL TO BE MEASURED BY RESTING THE PART ON A FLAT GAGE SURFACE.
- PRODUCT SPECIFICATION PS-87263 APPLIES.
- CAP : HIGH TEMPERATURE THERMOPLASTIC, UL RATED 94V-0, SUITABLE FOR SURFACE-MOUNT SOLDERING PROCESS. COLOR BLACK
- POSITION OF CAP TO BE CENTRAL WITH RESPECT TO DIMENSION "A"
- CONTACT FACTORY FOR DETAILS ON THIS PART NO.
- PARTS SHALL BE PACKED IN MOISTURE BARRIER BAG.
- P/N: 87263-3686 TO BE PACKED IN EMBOSSED TAPE TYPE B1.

SEE SHEET 3 EC NO: S2015-0829 DRWN:CGOH CHKD:ATSEE APPR:KLL IM 2015/04/16 2015/04/17 2015/04/17	QUALITY SYMBOLS $\nabla_A = 0$ $\nabla_G = 0$ $\nabla_F = 0$	GENERAL TOLERANCES (UNLESS SPECIFIED)		DIMENSION STYLE MM ONLY		SCALE NTS	DESIGN UNITS METRIC	THIRD ANGLE PROJECTION		
		4 PLACES	± ---	± ---	DRAWN BY	DATE	TITLE			
		3 PLACES	± ---	± ---	CHECKED BY	DATE	MGRID, B/ENTRY RECEPT. 2.80MM HT. W/LOC. PEGS W/CAP, SMT			
		2 PLACES	± 0.20	± ---	APPROVED BY	DATE				
1 PLACE	± ---	± ---	MLONG		2010/03/19	MATERIAL NO. SEE TABLE		DOCUMENT NO. SD-87263-**2*		
0 PLACE	±	±	ANGULAR ± 3° DRAFT WHERE APPLICABLE MUST REMAIN WITHIN DIMENSIONS		SIZE A3	SHEET NO. 1 OF 4				

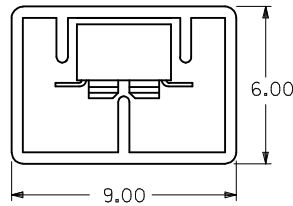
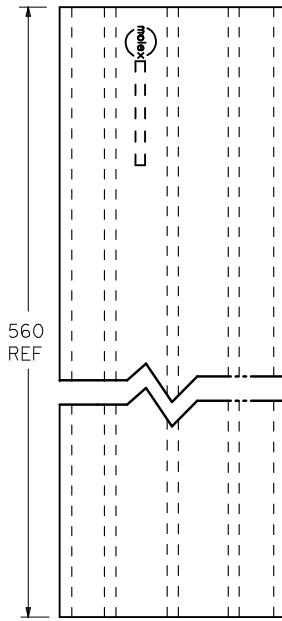

P/N 87263-***2*

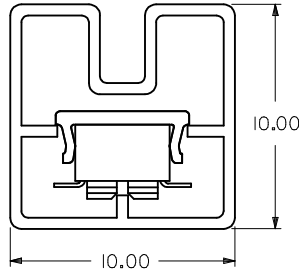
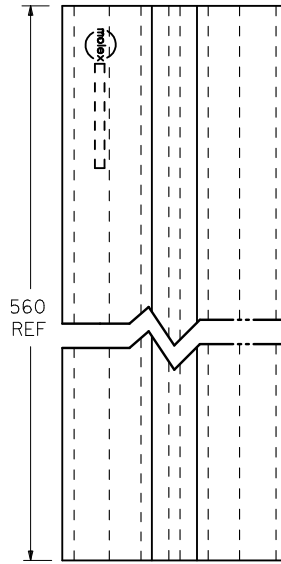

P/N 87263-***0*

CKT. SIZE	PART NO. FOR PARTS WITHOUT CAP	△ PART NO. FOR PARTS WITH CAP
4	87263-042*	87263-040*
6	87263-062*	87263-060*
8	87263-082*	87263-080*
10	87263-102*	87263-100*
12	87263-122*	87263-120*
14	87263-142*	87263-140*
16	87263-162*	87263-160*
18	87263-182*	87263-180*
20	87263-202*	87263-200*
22	87263-222*	87263-220*
24	87263-242*	87263-240*
26	87263-262*	87263-260*
28	87263-282*	87263-280*
30	87263-302*	87263-300*
32	87263-322*	87263-320*
34	87263-342*	87263-340*
36	87263-362*	87263-360*
38	87263-382*	87263-380*
40	87263-402*	87263-400*
42	87263-422*	87263-420*
44	△ 87263-442*	87263-440*

SEE SHEET 3 IEC NO: S2015-0829 DRWNG: CGOH CH'KD: ATSEE APPR: KHLIM 2015/04/16 2015/04/27 2015/04/27	QUALITY SYMBOLS	GENERAL TOLERANCES (UNLESS SPECIFIED)	DIMENSION STYLE	SCALE	DESIGN UNITS	THIRD ANGLE PROJECTION																		
	$F_A=0$ $F_B=0$ $F_C=0$	<table border="1"> <tr><th></th><th>mm</th><th>INCH</th></tr> <tr><td>4 PLACES</td><td>± ---</td><td>± ---</td></tr> <tr><td>3 PLACES</td><td>± ---</td><td>± ---</td></tr> <tr><td>2 PLACES</td><td>± 0.20</td><td>± ---</td></tr> <tr><td>1 PLACE</td><td>± ---</td><td>± ---</td></tr> <tr><td>0 PLACE</td><td>±</td><td>±</td></tr> </table>		mm	INCH	4 PLACES	± ---	± ---	3 PLACES	± ---	± ---	2 PLACES	± 0.20	± ---	1 PLACE	± ---	± ---	0 PLACE	±	±	MM ONLY	NTS	METRIC	
		mm	INCH																					
	4 PLACES	± ---	± ---																					
3 PLACES	± ---	± ---																						
2 PLACES	± 0.20	± ---																						
1 PLACE	± ---	± ---																						
0 PLACE	±	±																						
DRAWN BY: JDK CHECKED BY: MLA1 APPROVED BY: MLONG DATE: 1991/01/11 DATE: 1991/01/11 DATE: 2010/03/19	MATERIAL NO. SEE TABLE	TITLE MGRID, B/ENTRY RECEPT. 2.80MM HT. W/LOC. PEGS W/CAP, SMT			SHEET NO. 2 OF 4																			
J10	REV DESCRIPTION ANGULAR ± 3 ° DRAFT WHERE APPLICABLE MUST REMAIN WITHIN DIMENSIONS	SIZE A3 THIS DRAWING CONTAINS INFORMATION THAT IS PROPRIETARY TO MOLEX INCORPORATED AND SHOULD NOT BE USED WITHOUT WRITTEN PERMISSION	DOCUMENT NO. SD-87263-***2*																					

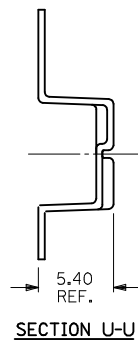
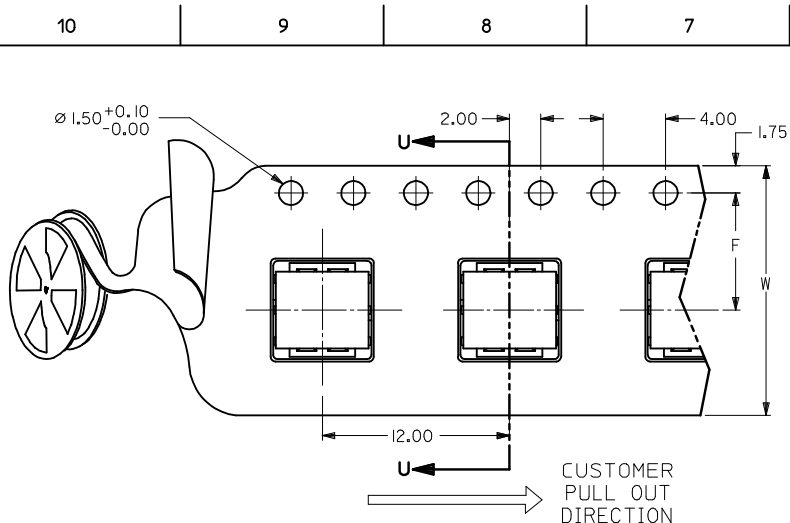

PART NO. 87263-***9* (CKTS 04 TO 14)
SINGLE SPROCKET HOLE T/REEL - TYPE A

△ PART NO. FOR PARTS WITHOUT CAP IN T/REEL	△ PART NO. FOR PARTS WITH CAP IN T/REEL	CKT. SIZE	F	So	W	T/REEL TYPE
87263-048*	87263-049*	4	11.5	-	24	A
87263-068*	87263-069*	6	11.5	-	24	
87263-088*	87263-089*	8	11.5	-	24	
87263-108*	87263-109*	10	11.5	-	24	
87263-128*	87263-129*	12	11.5	-	24	
87263-148*	87263-149*	14	11.5	-	24	
87263-168*	87263-169*	16	11.5	-	24	
87263-188*	87263-189*	18	14.2	28.4	32	
87263-208*	87263-209*	20	20.2	40.4	44	
87263-228*	87263-229*	22	20.2	40.4	44	
87263-248*	87263-249*	24	20.2	40.4	44	
87263-268*	87263-269*	26	20.2	40.4	44	
87263-288*	87263-289*	28	20.2	40.4	44	
87263-308*	87263-309*	30	20.2	40.4	44	
87263-328*	87263-329*	32	26.2	52.4	56	
87263-348*	87263-349*	34	-	-	-	
△ 87263-368*	87263-369*	36	26.2	52.4	56	
87263-388*	87263-389*	38	-	-	-	
87263-408*	87263-409*	40	-	-	-	
△ 87263-3686	-	36	26.2	52.4	56	B1

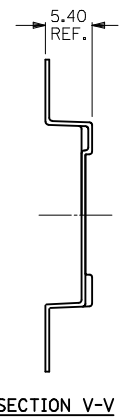
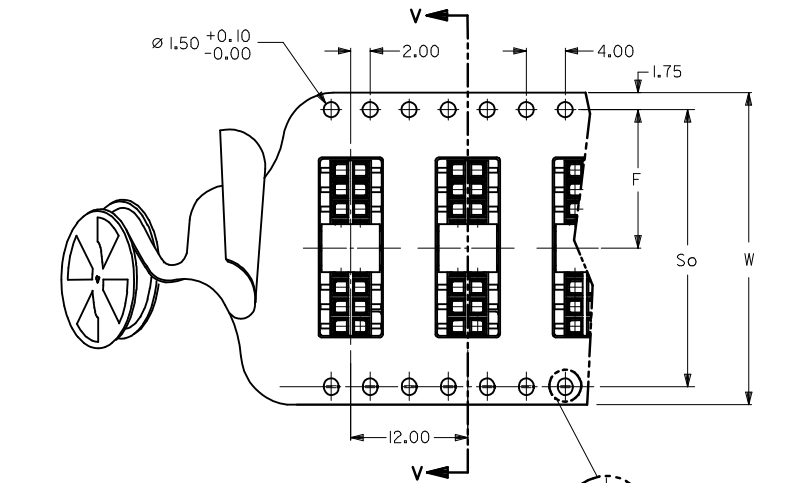

PART NO. 87263-***9* (CKTS 16 TO 40)
DOUBLE SPROCKET HOLE T/REEL - TYPE B

NOTES:

- LEADER AND TRAILER TAPE
- PEELING OFF FORCE OF THE TOP TAPE: 20-80gf.
(PEELING DIRECTION AS SHOWN IN FOLLOWING FIGURE)
- PACKAGING STANDARD IS AS PER EIA-481.
- TAPE & REEL QUANTITY: EMBOSSED TYPE A & B = 1000PCS/REEL
EMBOSSED TYPE B1 = 900PCS/REEL
- THE TAPE IS TREATED FOR ANTI-STATIC.

REVISE 87263-229* EC NO: S2015-0829 DRWN:CGOH 2015/04/16 CHKD:ATSEE 2015/04/17 APPR:KHLIM 2015/04/17	QUALITY SYMBOLS	GENERAL TOLERANCES (UNLESS SPECIFIED)	DIMENSION STYLE	SCALE	DESIGN UNITS	THIRD ANGLE PROJECTION																		
	$\nabla_A=0$ $\nabla_C=0$ $\nabla_P=0$	<table border="1"> <thead> <tr><th></th><th>mm</th><th>INCH</th></tr> </thead> <tbody> <tr><td>4 PLACES</td><td>± ---</td><td>± ---</td></tr> <tr><td>3 PLACES</td><td>± ---</td><td>± ---</td></tr> <tr><td>2 PLACES</td><td>± 0.20</td><td>± ---</td></tr> <tr><td>1 PLACE</td><td>± ---</td><td>± ---</td></tr> <tr><td>0 PLACE</td><td>±</td><td>±</td></tr> </tbody> </table>		mm	INCH	4 PLACES	± ---	± ---	3 PLACES	± ---	± ---	2 PLACES	± 0.20	± ---	1 PLACE	± ---	± ---	0 PLACE	±	±	MM ONLY	NTS	METRIC	
		mm	INCH																					
	4 PLACES	± ---	± ---																					
3 PLACES	± ---	± ---																						
2 PLACES	± 0.20	± ---																						
1 PLACE	± ---	± ---																						
0 PLACE	±	±																						
DESCRIPTION	ANGULAR ± 3 °	DRAWN BY	DATE	TITLE																				
J10	DRAFT WHERE APPLICABLE MUST REMAIN WITHIN DIMENSIONS	JDK	1991/01/11	MGRID, B/ENTRY RECEPT. 2.80MM HT. W/LOC. PEGS W/CAP, SMT																				
		CHECKED BY	DATE																					
		MLAI	1991/01/11																					
		APPROVED BY	DATE																					
		MLONG	2010/03/19																					
		MATERIAL NO.		SEE TABLE	DOCUMENT NO.	SHEET NO.																		
					SD-87263-***2*	3 OF 4																		
		SIZE		THIS DRAWING CONTAINS INFORMATION THAT IS PROPRIETARY TO MOLEX INCORPORATED AND SHOULD NOT BE USED WITHOUT WRITTEN PERMISSION																				
		A3																						

T/REEL TYPE B1

PART WITHOUT CAP IN T&R	CKT SIZE	Bo	Ko	Ao
9 87263-3686	36	36.40	5.00	6.60

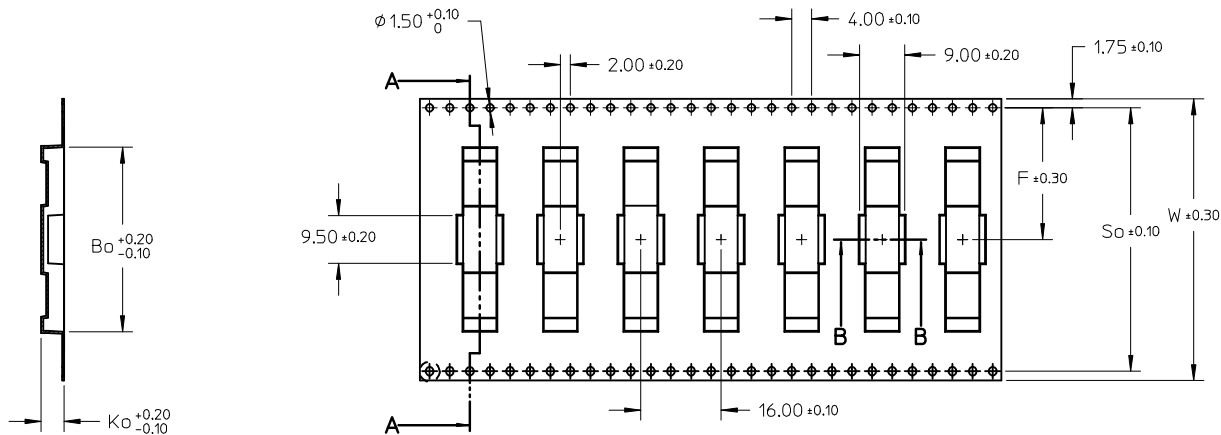

SECTION A-A

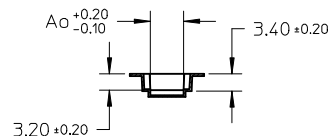

SECTION B-B

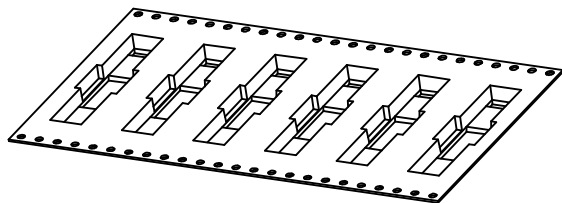

SEE SHEET 3 EC NO: S2015-0829 DRWING: G0H CHKD: AISEE APPR: KHLIM 2015/04/16 2015/04/17 2015/04/17	QUALITY SYMBOLS	GENERAL TOLERANCES (UNLESS SPECIFIED)		DIMENSION STYLE MM ONLY		SCALE NTS	DESIGN UNITS METRIC	THIRD ANGLE PROJECTION	
	$\nabla_A = 0$ $\nabla_C = 0$ $\nabla_P = 0$	4 PLACES ± --- ± --- 3 PLACES ± --- ± --- 2 PLACES ± 0.20 ± --- 1 PLACE ± --- ± --- 0 PLACE ± ±	mm	INCH	DRAWN BY JDK	DATE 1991/01/11	TITLE	MGRID, B/ENTRY RECEPT. 2.80MM HT. W/LOC. PEGS W/CAP, SMT	
	DESCRIPTION	DRAFT WHERE APPLICABLE MUST REMAIN WITHIN DIMENSIONS		MATERIAL NO. MLONG		DATE 2010/03/19	DOCUMENT NO. SD-87263-**2*		SHEET NO. 4 OF 4
	REV J10	ANGULAR ± 3 °		SEE TABLE		THIS DRAWING CONTAINS INFORMATION THAT IS PROPRIETARY TO MOLEX INCORPORATED AND SHOULD NOT BE USED WITHOUT WRITTEN PERMISSION			



Компания «ЭлектроПласт» предлагает заключение долгосрочных отношений при поставках импортных электронных компонентов на взаимовыгодных условиях!

Наши преимущества:

- Оперативные поставки широкого спектра электронных компонентов отечественного и импортного производства напрямую от производителей и с крупнейших мировых складов;
- Поставка более 17-ти миллионов наименований электронных компонентов;
- Поставка сложных, дефицитных, либо снятых с производства позиций;
- Оперативные сроки поставки под заказ (от 5 рабочих дней);
- Экспресс доставка в любую точку России;
- Техническая поддержка проекта, помощь в подборе аналогов, поставка прототипов;
- Система менеджмента качества сертифицирована по Международному стандарту ISO 9001;
- Лицензия ФСБ на осуществление работ с использованием сведений, составляющих государственную тайну;
- Поставка специализированных компонентов (Xilinx, Altera, Analog Devices, Intersil, Interpoint, Microsemi, Aeroflex, Peregrine, Syfer, Eurofarad, Texas Instrument, Miteq, Cobham, E2V, MA-COM, Hittite, Mini-Circuits, General Dynamics и др.);

Помимо этого, одним из направлений компании «ЭлектроПласт» является направление «Источники питания». Мы предлагаем Вам помощь Конструкторского отдела:

- Подбор оптимального решения, техническое обоснование при выборе компонента;
- Подбор аналогов;
- Консультации по применению компонента;
- Поставка образцов и прототипов;
- Техническая поддержка проекта;
- Защита от снятия компонента с производства.



Как с нами связаться

Телефон: 8 (812) 309 58 32 (многоканальный)

Факс: 8 (812) 320-02-42

Электронная почта: org@eplast1.ru

Адрес: 198099, г. Санкт-Петербург, ул. Калинина, дом 2, корпус 4, литера А.