

SECT. Z-Z

SECT. Y-Y

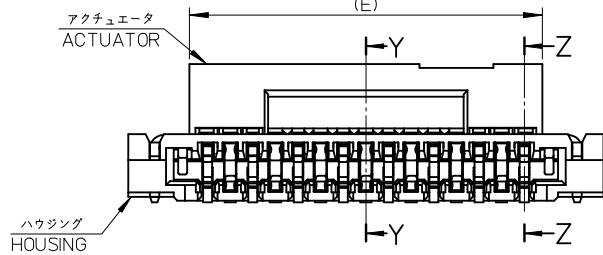

| | | | | | | | | |
|------|-------|------|------|------|------|-----------------------------|--------------|----------|
| 15.3 | 15.48 | 15.9 | 14.4 | 15.0 | 17.1 | 502250-5191 | 502250-5120 | 51 |
| 12.3 | 12.48 | 12.9 | 11.4 | 12.0 | 14.1 | 502250-4191 | 502250-4120 | 41 |
| 11.7 | 11.88 | 12.3 | 10.8 | 11.4 | 13.5 | 502250-3991 | 502250-3920 | 39 |
| 10.5 | 10.68 | 11.1 | 9.6 | 10.2 | 12.3 | 502250-3591 | 502250-3520 | 35 |
| 9.9 | 10.08 | 10.5 | 9.0 | 9.6 | 11.7 | 502250-3391 | 502250-3320 | 33 |
| 8.1 | 8.28 | 8.7 | 7.2 | 7.8 | 9.9 | 502250-2791 | 502250-2720 | 27 |
| 6.9 | 7.08 | 7.5 | 6.0 | 6.6 | 8.7 | 502250-2391 | 502250-2320 | 23 |
| 6.3 | 6.48 | 6.9 | 5.4 | 6.0 | 8.1 | 502250-2191 | 502250-2120 | 21 |
| 5.1 | 5.28 | 5.7 | 4.2 | 4.8 | 6.9 | 502250-1791 | 502250-1720 | 17 |
| F | E | D | C | B | A | EMBOSSED TAPE PKG ORDER NO. | MATERIAL No. | CIRCUITS |

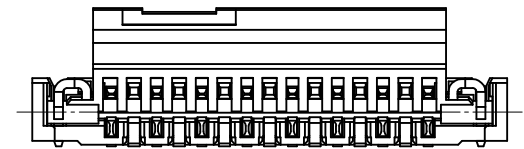
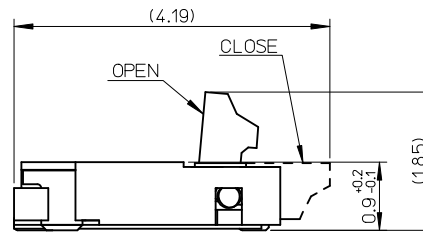
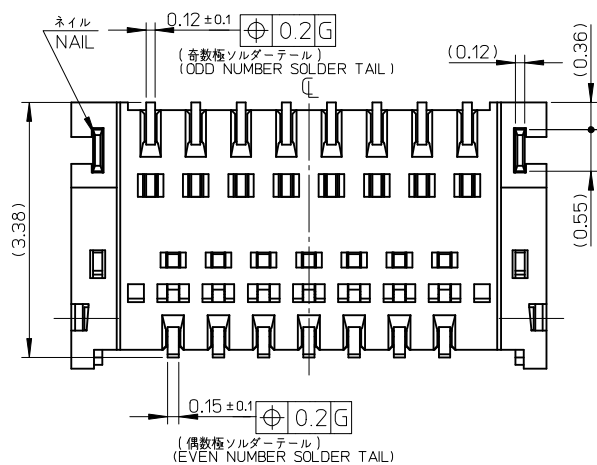

| | | | | | | |
|---|--|---|---|-------------------------------|------------------------|--|
| REVISED EC NO: J2009-1500 DR: NINTAKASAKI 2008/12/09 CHKD: MHAYASHI 2008/12/11 APPR: NUKITA 2008/12/11 | GENERAL TOLERANCES (UNLESS SPECIFIED) | DIMENSION STYLE MM ONLY | SCALE 15:1 | DESIGN UNITS METRIC | THIRD ANGLE PROJECTION | |
| | 10 UNDER ±0.2 10 OVER 30 UNDER ±0.25 30 OVER ±0.3 | DRAWN BY T. HIRAYAMA DATE 2008/01/31 | TITLE 0.3 FPC CONN E/O B/F HSG ASSY HGT=0.9MM | MODEL No. 502250-**20 | | |
| | ANGULAR ±3 DRAFT WHERE APPLICABLE MUST REMAIN WITHIN DIMENSIONS | CHECKED BY K. MORIKAWA DATE 2008/01/31 | MOLEX INCORPORATED | DOCUMENT NO. SD-502250-003 | | |
| | SEE TABLE | APPROVED BY H. HIRATA DATE 2008/01/31 | THIS DRAWING CONTAINS INFORMATION THAT IS PROPRIETARY TO MOLEX INCORPORATED AND SHOULD NOT BE USED WITHOUT WRITTEN PERMISSION | SHEET NO. 1 OF 3 | | |

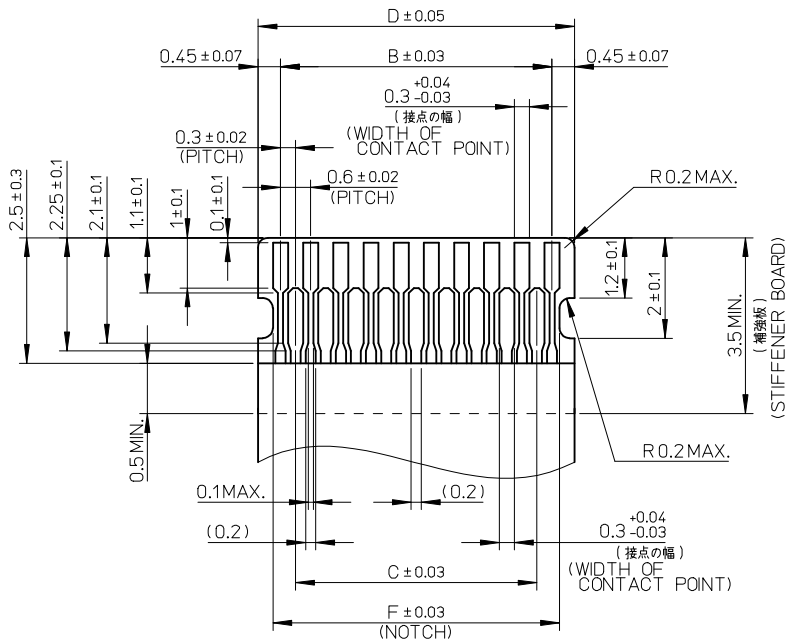

標準 FPC
STANDARD

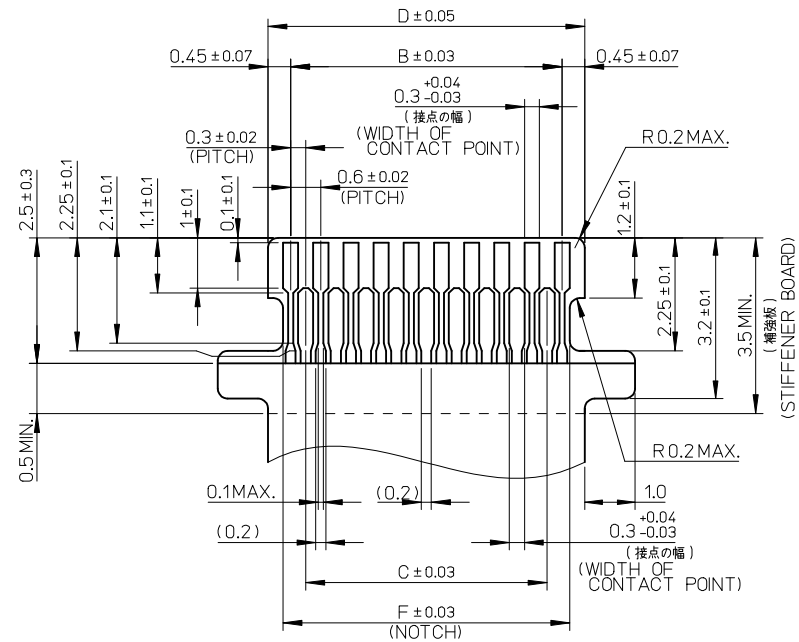

挿入位置確認用耳つきFPC
WITH EARS FOR FPC INSERTION ALIGNMENT

嵌合FPC推奨寸法
APPLICABLE FPC
RECOMMENDED DIMENSION
(仕上がり厚さ : 0.2 ± 0.03)
(THICKNESS : 0.2 ± 0.03)

FPCについて:

抜き方向は、導体側から補強板側を推奨致します。
補強フィルム材質は、ポリイミドを推奨致します。
接着剤は熱硬化接着剤を推奨します。
尚、接着剤の接点部への付着は導通不良の原因になりますので、
染み出しが無い様、お願い致します。

ABOUT FPC:

RECOMMENDED PUNCHER DIRECTION:
FROM CONDUCTOR SIDE TO STIFFENER FILM SIDE.
RECOMMENDED MATERIAL:
STIFFENER FILM : POLYIMIDE
BONDING AGENT : THERMOSETTING AGENT
PLEASE PUT APPROPRIATE AMOUNT OF ADHESIVE ON ADHEREND
BECAUSE THERE IS A POSSIBILITY THAT THE EXTRA ADHESIVE
CAUSES THE DEFECT IN ELECTRICAL CONTINUITY.

| | | | | | | | | | |
|---|--------------------|---------------------------------------|--------|--|--------------------|---|------------------------|------------------------|--|
| SEE SHEET 1 EC NO: J2009-1500 DRAWN: TAKASAKI 2008/12/09 CHKD: HAYASHI 2008/12/11 APPR: NUKITA 2008/12/11 | DESCRIPTION REV | GENERAL TOLERANCES (UNLESS SPECIFIED) | | DIMENSION STYLE MM ONLY | | SCALE 10:1 | DESIGN UNITS METRIC | THIRD ANGLE PROJECTION | |
| | | 10 UNDER | ± 0.2 | DRAWN BY T. HIRAYAMA | DATE 2008/01/31 | TITLE 0.3 FPC CONN E/O B/F HSG ASSY HGT=0.9MM | | | |
| | | 10 OVER 30 UNDER | ± 0.25 | CHECKED BY K. MORIKAWA | DATE 2008/01/31 | MOLEX INCORPORATED DOCUMENT NO. SD-502250-003 | | | |
| | | 30 OVER | ± 0.3 | APPROVED BY H. HIRATA | DATE 2008/01/31 | | | | |
| ANGULAR ± 3° DRAFT WHERE APPLICABLE MUST REMAIN WITHIN DIMENSIONS | | SEE SHEET 1 | | THIS DRAWING CONTAINS INFORMATION THAT IS PROPRIETARY TO MOLEX INCORPORATED AND SHOULD NOT BE USED WITHOUT WRITTEN PERMISSION | | | | | |

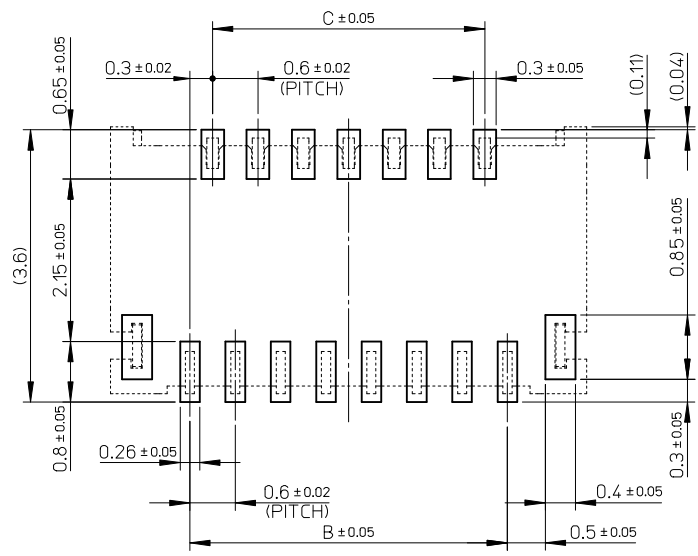

推奨基板レイアウト図 (マウント面)
P.C BOARD PATTERN
RECOMMENDED DIMENSION
(MOUNTING AREA)

注記 NOTES

1. 使用材料 MATERIAL
ハウジング : 液晶ポリマー ガラス充填 UL94V-0 (ナチュラル)
HOUSING : LIQUID CRYSTAL POLYMER (GLASS FILLED)
UL94V-0(COLOR:NATURAL)
アクチュエータ : ポリフェニレンサルファイド ガラス充填 UL94V-0 (黒)
ACTUATOR : POLYPHENYLENE SULFIDE (GLASS FILLED)
UL94V-0(COLOR:BLACK)
ターミナル : 銅ニッケルスズ合金、ニッケル下地部分金メッキ (接触部及びテール部)
TERMINAL : COPPER NICKEL TIN ALLOY,
PARTLY GOLD(CONTACT,TAIL) OVER NICKEL PLATING
ネイル : リン青銅、ニッケル下地鍍めつき
FITTING NAIL : PHOSPHOR-BRONZE, TIN OVER NICKEL PLATING
2. ソルダータール半田付け面、及びネイル半田付け面の平坦度 : 0.1mmMAX.
COPLANARITY OF SOLDER TAILS AND FITTING NAILS
TO BE 0.1mm MAX.
3. 基板実装前にアクチュエータを操作しないで下さい。
PLEASE DO NOT OPERATE THE ACTUATOR BEFORE MOUNTING.
必ず基板に実装し、FPCを挿入してからアクチュエータを操作して下さい。
PLEASE OPERATE THE ACTUATOR AFTER MOUNTING ON
THE SUBSTRATE,AND MATING FPC.
4. 推奨メタルマスク RECOMMENDED METAL MASK SPECIFICATION
マスク厚 : 0.1mm MASK THICKNESS : 0.1mm
なお、貴社にて上記以外でご使用頂く場合は、事前に確認頂きますようお願い致します。
WHEN USE IT OTHER THAN THE ABOVE IN YOUR COMPANY,
PLEASE CONFIRM IT BEFOREHAND.
5. ELV 及び RoHS適合品
ELV AND RoHS COMPLIANT.

| | | | | | | | | | |
|--|-------------|---|--------|-----------------------------|--------------------|---|------------------------|------------------------|--|
| SEE SHEET 1 EC NO.: J2009-1500 DRWN:MTAKASAKI 2008/12/09 CHKD:MHAYASHI 2008/12/11 APPR:NUKITA 2008/12/11 | DESCRIPTION | GENERAL TOLERANCES (UNLESS SPECIFIED) | | DIMENSION STYLE MM ONLY | | SCALE 10:1 | DESIGN UNITS METRIC | THIRD ANGLE PROJECTION | |
| | | 10 UNDER | ± 0.2 | DRAWN BY T. HIRAYAMA | DATE 2008/01/31 | TITLE 0.3 FPC CONN E/O B/F HSG ASSY HGT=0.9MM | | | |
| | | 10 OVER 30 UNDER | ± 0.25 | CHECKED BY K. MORIKAWA | DATE 2008/01/31 | MOLEX INCORPORATED | | | |
| | | 30 OVER | ± 0.3 | APPROVED BY H. HIRATA | DATE 2008/01/31 | | | | |
| ANGULAR | ± 3 ° | DRAFT WHERE APPLICABLE MUST REMAIN WITHIN DIMENSIONS | | MATERIAL NO. SEE SHEET 1 | | DOCUMENT NO. SD-502250-003 | SHEET NO. 3 OF 3 | | |
| REV D | | SIZE A3 THIS DRAWING CONTAINS INFORMATION THAT IS PROPRIETARY TO MOLEX INCORPORATED AND SHOULD NOT BE USED WITHOUT WRITTEN PERMISSION | | | | | | | |

NOTES

- 製品 (502250-**20) の詳細寸法については、
図面SD-502250-003をご参照ください
IN THE PACKAGE, PART NO. 502250-**20 DETAILED DIMENSIONS,
REFER TO SALES DRAWING NO. SD-502250-003.
- 梱包数量: 3000 個/リール
NUMBER OF CONNECTORS:3000 PCS/REEL
- リードテープ長さ
LEAD TAPE LENGTH

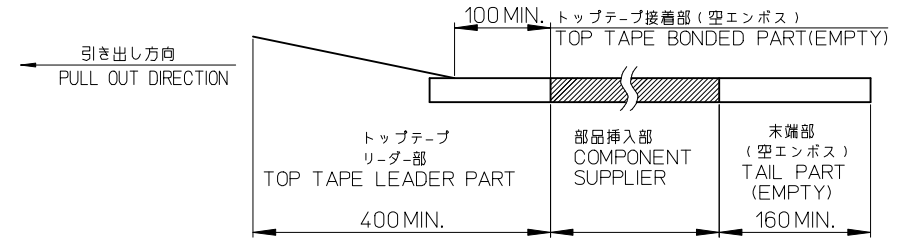
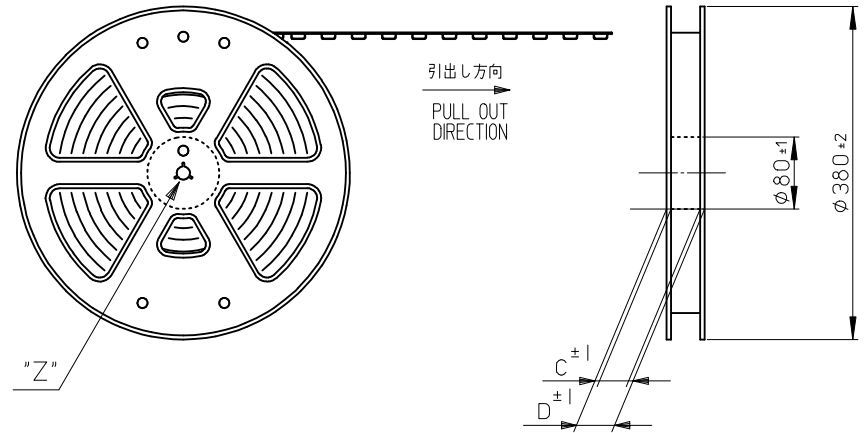

- 材料(MATERIAL)
キャリアテープ(CARRIER TAPE): ポリスチレン(POLYSTYRENE)
トップテープ(TOP TAPE): PET, OTHER
リール(REEL): ポリスチレン(POLYSTYRENE)<リサイクル材を含む>
<RECYCLE MATERIAL CONTAINED>
- ELV 及び RoHS適合品
ELV AND RoHS COMPLIANT.

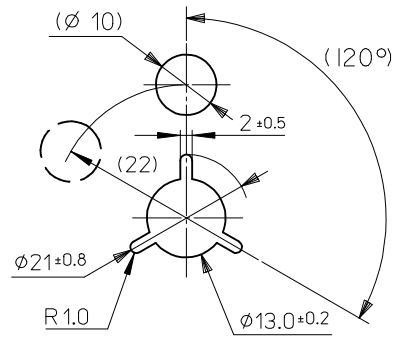

DETAIL "Z"

| | | | | | | | |
|---|---------------------------------------|------------|---|--|--|--|-----------|
| REVISED EC NO: J2009-1500 DRWN:MTAKASAKI 2008/12/09 CHKD:MHAYASHI 2008/12/11 APPR:NUKITA 2008/12/11 | GENERAL TOLERANCES (UNLESS SPECIFIED) | | DIMENSION STYLE MM ONLY | | SCALE --- | 502250-**91 | MODEL NO. |
| | 10 UNDER ±0.2 | | DRAWN BY DATE T. HIRAYAMA 2008/01/31 | | TITLE | 0.3 FPC CONN E/O B/F HGT=0.9MM EMBSTP PKG | |
| | 10 OVER 30 UNDER ±0.25 | | CHECKED BY DATE K. MORIKAWA 2008/01/31 | | APPROVED BY DATE H. HIRATA 2008/01/31 | MOLEX INCORPORATED | |
| | 30 OVER ±0.3 | | MATERIAL NO. | | DOCUMENT NO. | SD-502250-004 | |
| ANGULAR ±3 ° | | SEE CHART | | SHEET NO. | | 1 OF 3 | |
| DRAFT WHERE APPLICABLE MUST REMAIN WITHIN DIMENSIONS | | SIZE A3 | | THIS DRAWING CONTAINS INFORMATION THAT IS PROPRIETARY TO MOLEX INCORPORATED AND SHOULD NOT BE USED WITHOUT WRITTEN PERMISSION | | | |

引き出し方向
PULL OUT DIRECTION

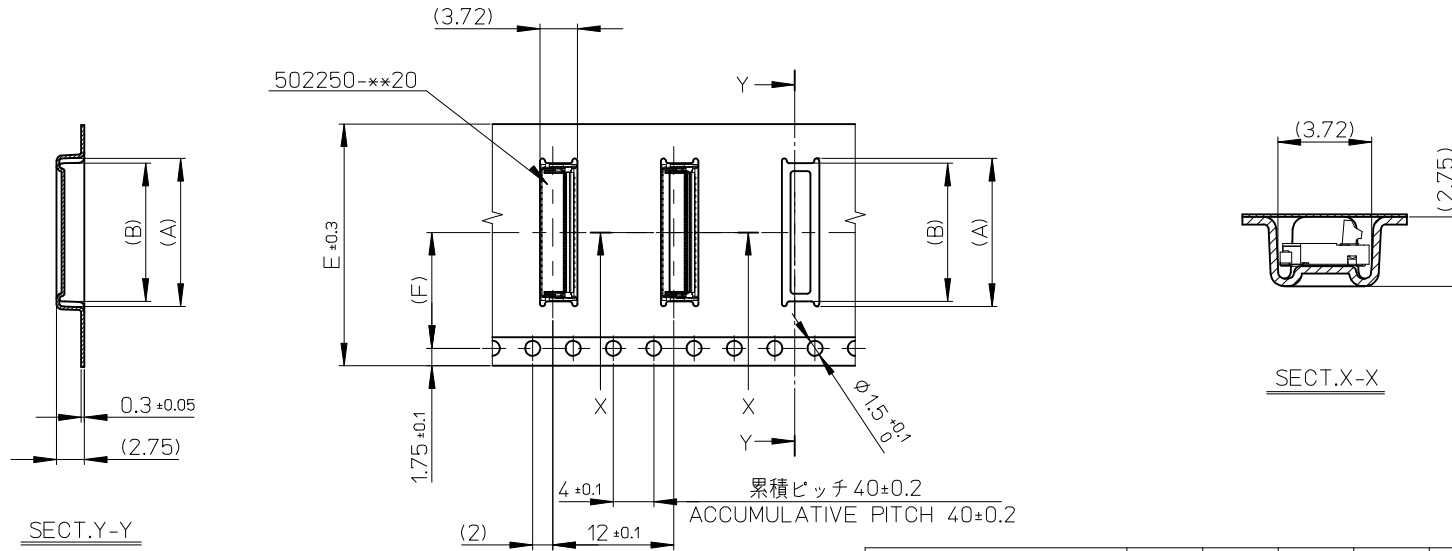

| | | | | | | | | |
|--------------------------------|------|----|------|------|------|------|----------------------|---------------|
| 24 | 11.5 | 24 | 29.4 | 25.4 | 14.3 | 15.3 | 502250-4191 | 41 |
| | | | | | 13.7 | 14.7 | 502250-3991 | 39 |
| | | | | | 12.5 | 13.5 | 502250-3591 | 35 |
| | | | | | 11.9 | 12.9 | 502250-3391 | 33 |
| | | | | | 10.1 | 11.1 | 502250-2791 | 27 |
| | | | | | 8.9 | 9.9 | 502250-2391 | 23 |
| 16 | 7.5 | 16 | 21.4 | 17.4 | 8.3 | 9.3 | 502250-2191 | 21 |
| | | | | | 7.1 | 8.1 | 502250-1791 | 17 |
| キャリアテープ幅 CARRIER TAPE WIDTH | | | | | (F) | E | D | C |
| | | | | | (B) | (A) | 製品番号 MATERIAL NO. | 極数 CIRCUIT |

| | | | | | | | |
|---|---------------------------------------|-------|---|--|--|------------------------|--|
| SEE SHEET 1 EC NO.: J2009-1500 DRWN: MTAKASAKI 2008/12/09 CHKD: MHAYASHI 2008/12/11 APPR: NUKITA 2008/12/11 | GENERAL TOLERANCES (UNLESS SPECIFIED) | | DIMENSION STYLE MM ONLY | | SCALE --- | MODEL No. 502250-**-91 | |
| | 10 UNDER | ±0.2 | DRAWN BY DATE | | TITLE | | |
| | 10 OVER 30 UNDER | ±0.25 | T. HIRAYAMA 2008/01/31 | | 0.3 FPC CONN E/O B/F HGT=0.9MM EMBSTP PKG | | |
| | 30 OVER | ±0.3 | CHECKED BY DATE | | K. MORIKAWA 2008/01/31 | | |
| DESCRIPTION ANGULAR ±3 ° DRAFT WHERE APPLICABLE MUST REMAIN WITHIN DIMENSIONS | APPROVED BY DATE | | MATERIAL NO. | | MOLEX INCORPORATED DOCUMENT NO. SD-502250-004 | | |
| | H. HIRATA 2008/01/31 | | SEE CHART | | SHEET NO. 2 OF 3 | | |
| | SIZE A3 | | THIS DRAWING CONTAINS INFORMATION THAT IS PROPRIETARY TO MOLEX INCORPORATED AND SHOULD NOT BE USED WITHOUT WRITTEN PERMISSION | | | | |

引き出し方向
PULL OUT DIRECTION

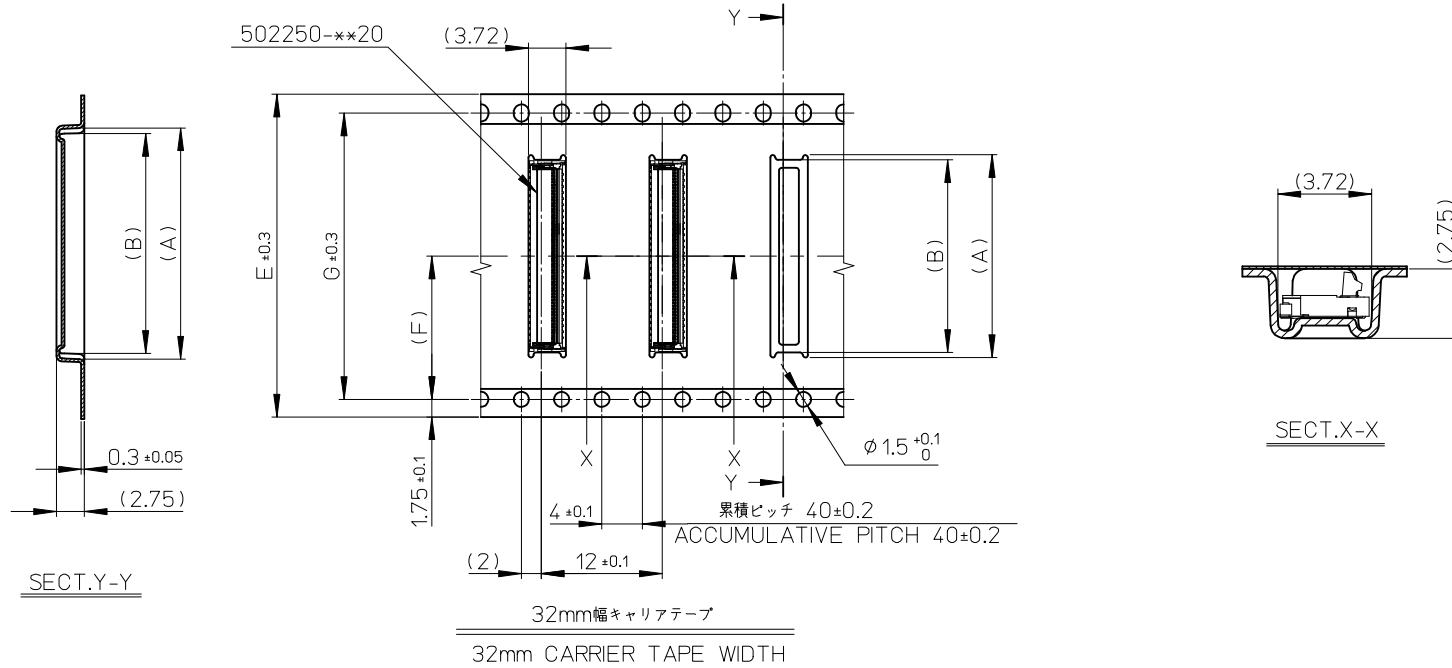

| | | | | | | | | | |
|--------------------------------|------|------|----|------|------|------|------|----------------------|---------------|
| 32 | 28.4 | 14.2 | 32 | 37.4 | 33.4 | 17.3 | 18.3 | 502250-5191 | 51 |
| キャリアテープ幅 CARRIER TAPE WIDTH | G | (F) | E | D | C | (B) | (A) | 製品番号 MATERIAL NO. | 極数 CIRCUIT |

| | | | | | | | |
|--|---------------------------------------|--|----------------------------|---|---|-------------------------|--|
| SEE SHEET 1 EC NO.: J2009-1500 DRWN: MTAKASAKI 2008/12/09 CHKD: HAYASHI 2008/12/11 APPR: NUKITA 2008/12/11 | GENERAL TOLERANCES (UNLESS SPECIFIED) | | DIMENSION STYLE MM ONLY | | SCALE --- | MODEL No. 502250-**91 | |
| | 10 UNDER | ±0.2 | DRAWN BY T. HIRAYAMA | DATE 2008/01/31 | TITLE 0.3 FPC CONN E/O B/F HGT=0.9MM EMBSTP PKG | | |
| | 10 OVER 30 UNDER | ±0.25 | CHECKED BY K. MORIKAWA | DATE 2008/01/31 | MATERIAL NO. 502250-004 | | |
| | 30 OVER | ±0.3 | APPROVED BY H. HIRATA | DATE 2008/01/31 | SHEET NO. 3 OF 3 | | |
| | ANGULAR ±3 ° | DRAFT WHERE APPLICABLE MUST REMAIN WITHIN DIMENSIONS | | SEE TABLE | | MATERIAL NO. 502250-004 | |
| | | | | THIS DRAWING CONTAINS INFORMATION THAT IS PROPRIETARY TO MOLEX INCORPORATED AND SHOULD NOT BE USED WITHOUT WRITTEN PERMISSION | | | |



Компания «ЭлектроПласт» предлагает заключение долгосрочных отношений при поставках импортных электронных компонентов на взаимовыгодных условиях!

Наши преимущества:

- Оперативные поставки широкого спектра электронных компонентов отечественного и импортного производства напрямую от производителей и с крупнейших мировых складов;
- Поставка более 17-ти миллионов наименований электронных компонентов;
- Поставка сложных, дефицитных, либо снятых с производства позиций;
- Оперативные сроки поставки под заказ (от 5 рабочих дней);
- Экспресс доставка в любую точку России;
- Техническая поддержка проекта, помощь в подборе аналогов, поставка прототипов;
- Система менеджмента качества сертифицирована по Международному стандарту ISO 9001;
- Лицензия ФСБ на осуществление работ с использованием сведений, составляющих государственную тайну;
- Поставка специализированных компонентов (Xilinx, Altera, Analog Devices, Intersil, Interpoint, Microsemi, Aeroflex, Peregrine, Syfer, Eurofarad, Texas Instrument, Miteq, Cobham, E2V, MA-COM, Hittite, Mini-Circuits, General Dynamics и др.);

Помимо этого, одним из направлений компании «ЭлектроПласт» является направление «Источники питания». Мы предлагаем Вам помощь Конструкторского отдела:

- Подбор оптимального решения, техническое обоснование при выборе компонента;
- Подбор аналогов;
- Консультации по применению компонента;
- Поставка образцов и прототипов;
- Техническая поддержка проекта;
- Защита от снятия компонента с производства.



Как с нами связаться

Телефон: 8 (812) 309 58 32 (многоканальный)

Факс: 8 (812) 320-02-42

Электронная почта: org@eplast1.ru

Адрес: 198099, г. Санкт-Петербург, ул. Калинина, дом 2, корпус 4, литера А.