

8 PIN DIP LOW INPUT CURRENT HIGH GAIN SPLIT DARLINGTON PHOTOCOUPLER

6N138 6N139

Features:

- High current transfer ratio – 2000% typical
- High isolation voltage between input and output ($V_{iso}=5000 V_{rms}$)
- Guaranteed performance from 0°C to 70°C
- Pb free and RoHS compliant.
- UL approved (No. 214129)
- VDE approved (No. 132249)
- SEMKO approved
- NEMKO approved
- DEMKO approved
- FIMKO approved
- CSA approved (No. 2037145)

Description

The 6N138 and 6N139 devices each consists of an infrared emitting diode, optically coupled to a high gain split Darlington photo detector. They provide extremely high current transfer ratio between input and output, with access to a base terminal to adjust the gain bandwidth.

These devices are packaged in an 8-pin DIP package and available in wide-lead spacing and SMD options.

Applications

- Digital logic ground isolation
- RS-232C line receiver
- Low input current line receiver
- Microprocessor bus isolation
- Current loop receiver

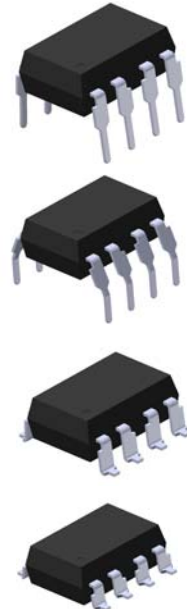

Schematic

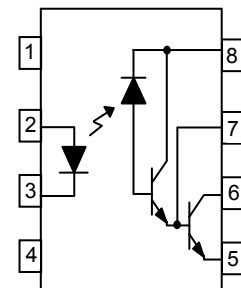

Pin Configuration

1. No Connection
2. Anode
3. Cathode
4. No Connection
5. Gnd
6. Vout
7. V_B
8. V_C



LIGHTING FOREVER

8 PIN DIP LOW INPUT CURRENT HIGH GAIN SPLIT DARLINGTON PHOTOCOUPLER

6N138 6N139

Absolute Maximum Ratings ($T_a=25^{\circ}\text{C}$ unless otherwise specified)

Parameter		Symbol	Rating	Unit	
Input	Forward current	I_F	20	mA	
	Peak forward current (50% duty, 1ms P.W)	I_{FP}	40	mA	
	Peak transient current ($\leq 1 \mu\text{s}$ P.W, 300pps)	I_{Ftrans}	1	A	
	Reverse voltage	V_R	5	V	
	Power dissipation	P_{IN}	45	mW	
Output	Power dissipation	P_O	100	mW	
	Output current	I_O	60	mA	
	Emitter-Base Reverse Voltage	VER	0.5	V	
	Output voltage	6N138	V_O	-0.5 to 7	V
		6N139		-0.5 to 18	V
	Supply voltage	6N138	V_{CC}	-0.5 to 7	V
6N139		-0.5 to 18		V	
Isolation voltage ^{*1}		V_{ISO}	5000	V rms	
Operating temperature		T_{OPR}	-40 ~ +85	$^{\circ}\text{C}$	
Storage temperature		T_{STG}	-55 ~ +125	$^{\circ}\text{C}$	
Soldering temperature ^{*2}		T_{SOL}	260	$^{\circ}\text{C}$	

Notes

*1 AC for 1 minute, R.H.= 40 ~ 60% R.H. In this test, pins 1, 2, 3, 4 are shorted together, and pins 5, 6, 7, 8 are shorted together.

*2 For 10 seconds.



LIGHTING FOREVER

8 PIN DIP LOW INPUT CURRENT HIGH GAIN SPLIT DARLINGTON PHOTOCOUPLER

6N138 6N139

Electrical Characteristics ($T_a=0$ to 70°C unless specified otherwise)

Input

Parameter	Symbol	Min.	Typ.*	Max.	Unit	Condition
Forward voltage	V_F	-	1.3	1.7	V	$I_F = 1.6\text{mA}$
Reverse Voltage	V_R	5.0	-	-	V	$I_R = 10\mu\text{A}$, $T_A=25^\circ\text{C}$
Temperature coefficient of forward voltage	$\Delta V_F/\Delta T_A$	-	-1.8	-	mV/ $^\circ\text{C}$	$I_F=1.6\text{mA}$

Output

Parameter	Symbol	Min.	Typ.*	Max.	Unit	Condition	
Logic High Output Current	6N139	-	0.01	100	μA	$I_F=0\text{mA}$, $V_O=V_{CC}=18\text{V}$	
	6N138	-	-	250			
Logic Low Supply Current	6N138 6N139	I_{CCL}	-	0.6	1.5	mA	$I_F=1.6\text{mA}$, $V_O=\text{Open}$, $V_{CC}=18\text{V}$
Logic High Supply Current	6N138 6N139	I_{CCH}	-	0.05	10	μA	$I_F=0\text{mA}$, $V_O=\text{Open}$, $V_{CC}=18\text{V}$

Transfer Characteristics ($T_a=0$ to 70°C unless specified otherwise, $V_{CC}=4.5\text{V}$)

Parameter	Symbol	Min.	Typ.*	Max.	Unit	Condition	
Current Transfer Ratio	6N139	CTR	400	2500	-	%	$I_F = 0.5\text{mA}$, $V_O = 0.4\text{V}$, $V_{CC}=4.5\text{V}$
			500	2000	-		$I_F = 1.6\text{mA}$, $V_O = 0.4\text{V}$, $V_{CC}=4.5\text{V}$
	6N138		300	2000	-		
Logic Low Output Voltage	6N139	V_{OL}	-	0.05	0.4	V	$I_F = 0.5\text{mA}$, $I_O = 2\text{mA}$, $V_{CC}=4.5\text{V}$
			-	0.09	0.4		$I_F = 1.6\text{mA}$, $I_O = 8\text{mA}$, $V_{CC}=4.5\text{V}$
			-	0.12	0.4		$I_F = 5\text{mA}$, $I_O = 15\text{mA}$, $V_{CC}=4.5\text{V}$
			-	0.17	0.4		$I_F = 12\text{mA}$, $I_O = 24\text{mA}$, $V_{CC}=4.5\text{V}$
	6N138		-	0.06	0.4		$I_F = 1.6\text{mA}$, $I_O = 4.8\text{mA}$, $V_{CC}=4.5\text{V}$

* Typical values at $T_a = 25^\circ\text{C}$

8 PIN DIP LOW INPUT CURRENT HIGH GAIN SPLIT DARLINGTON PHOTOCOUPLER

6N138 6N139

Switching Characteristics (T_a=0 to 70°C unless specified otherwise, V_{cc}=5V)

Parameter	Symbol	Min.	Typ.*	Max.	Unit	Condition	
Propagation Delay Time to Logic Low (Fig. 13)	6N139	TPHL	-	5	25	μs	I _F = 0.5mA , R _L =4.7kΩ, T _A =25°C
			-	-	30		I _F = 0.5mA , R _L =4.7kΩ
			-	0.2	1		I _F = 12mA , R _L =270Ω, T _A =25°C
	6N138	TPHL	-	-	2		I _F = 12mA , R _L =270Ω
			-	1.4	10		I _F = 1.6mA , R _L =2.2kΩ, T _A =25°C
			-	-	15		I _F = 1.6mA , R _L =2.2kΩ
Propagation Delay Time to Logic High (Fig. 13)	6N139	TPLH	-	16	60	μs	I _F = 0.5mA , R _L =4.7kΩ, T _A =25°C
			-	-	90		I _F = 0.5mA , R _L =4.7kΩ
			-	1.7	7		I _F = 12mA , R _L =270Ω, T _A =25°C
	6N138	TPLH	-	-	10		I _F = 12mA , R _L =270Ω
			-	8	35		I _F = 1.6mA , R _L =2.2kΩ, T _A =25°C
			-	-	50		I _F = 1.6mA , R _L =2.2kΩ
Common Mode Transient Immunity at Logic High (Fig. 14) ^{*3}	CM _H	1,000	-	-	V/μs	I _F = 0mA , V _{CM} =10Vp-p, R _L =2.2KΩ, T _A =25°C	
Common Mode Transient Immunity at Logic Low (Fig. 14) ^{*3}	CM _L	1,000	-	-	V/μs	I _F = 1.6mA , V _{CM} =10Vp-p, R _L =2.2KΩ, T _A =25°C	

* Typical values at T_a = 25°C

8 PIN DIP LOW INPUT CURRENT HIGH GAIN SPLIT DARLINGTON PHOTOCOUPLER

6N138 6N139

Typical Performance Curves

Fig.1 LED Forward Current vs. Forward Voltage

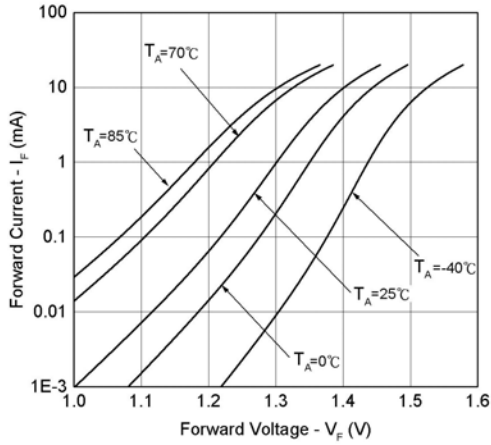

Fig.2 LED Forward Voltage vs. Temperature

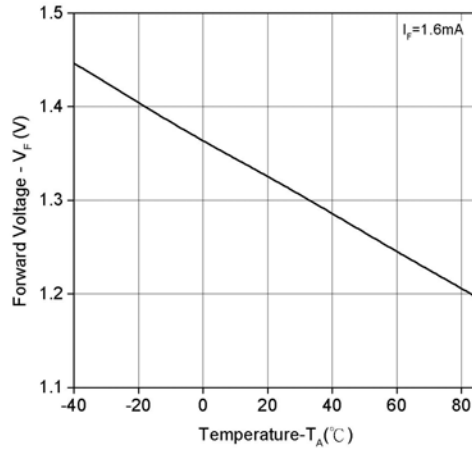

Fig.3 Output Current vs. Output Voltage

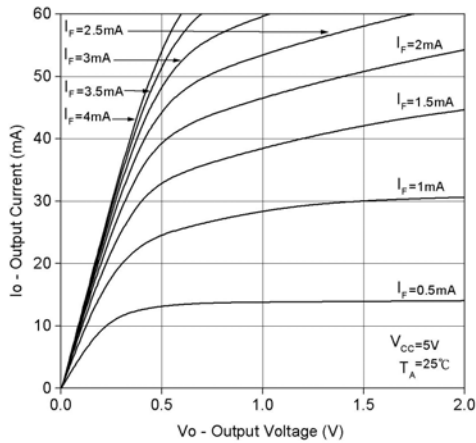

Fig.4 Output Current vs. Input Diode Forward Current

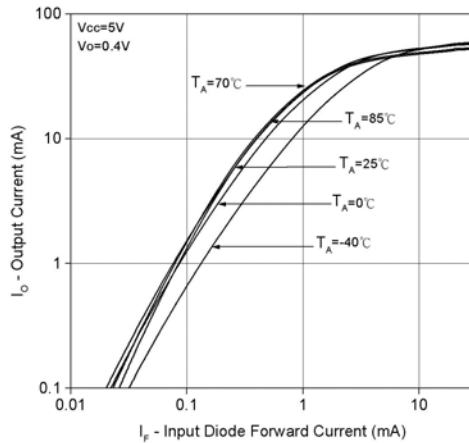

Fig.5 Current Transfer Ratio vs. Forward Current

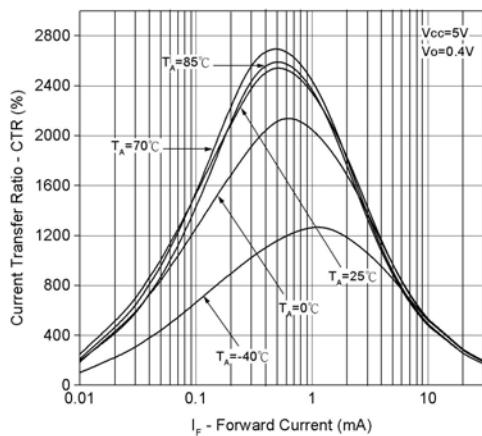
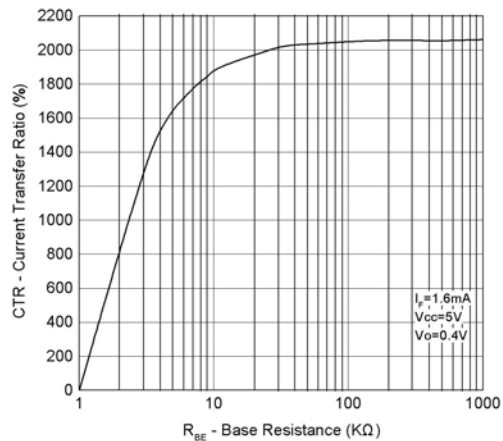

Fig.6 Current Transfer Ratio vs. Base-Emitter Resistance



8 PIN DIP LOW INPUT CURRENT HIGH GAIN SPLIT DARLINGTON PHOTOCOUPLER

6N138 6N139

Fig.7 Non-saturated Rise and Fall Times vs. Load Resistance

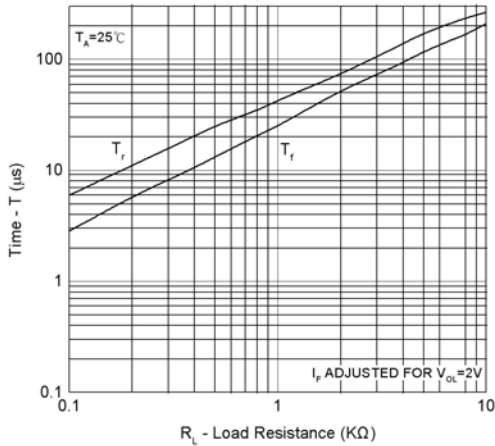

Fig.8 Propagation Delay To Logic Low vs. Base-Emitter Resistance

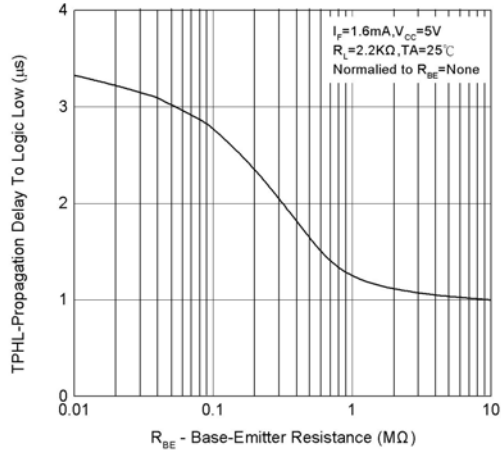

Fig.9 Propagation Delay vs. Input Diode Forward Current

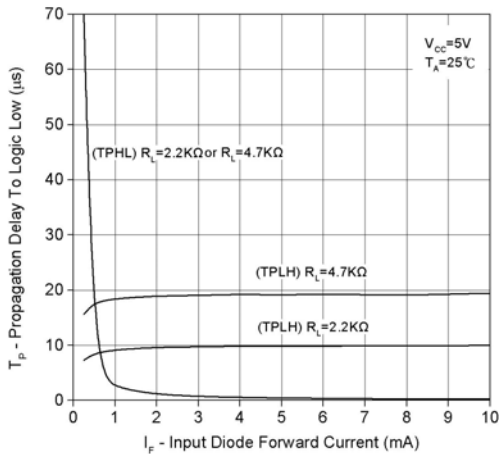

Fig.10 Propagation Delay to Logic Low vs. Pulse Period

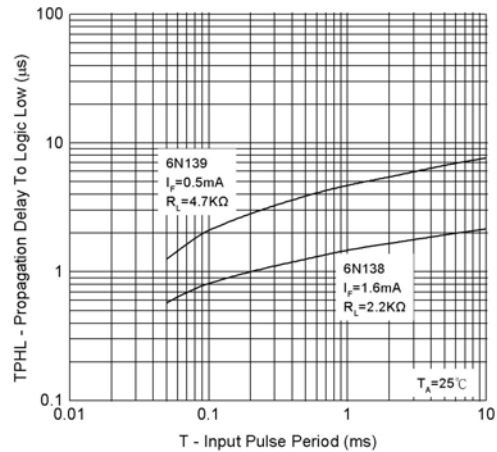

Fig.11 Propagation Delay vs. Temperature

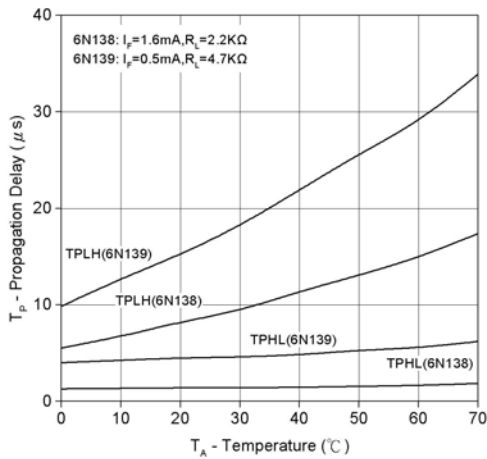
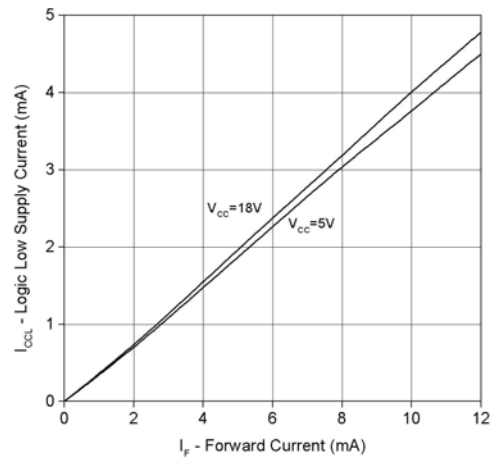

Fig.12 Logic Low Supply Current vs. Input Diode Forward Current



**8 PIN DIP LOW INPUT CURRENT HIGH GAIN
SPLIT DARLINGTON PHOTOCOUPLER**

6N138 6N139

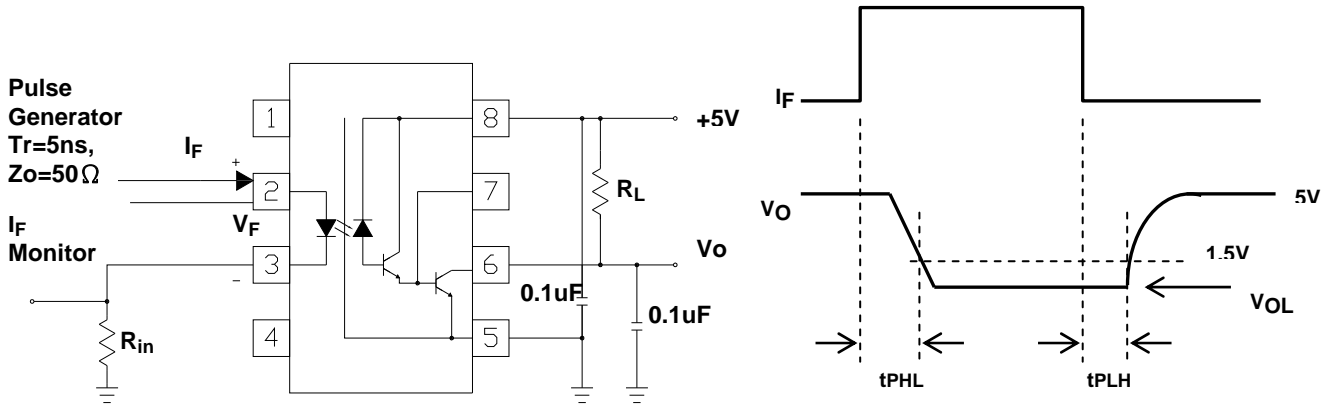

Fig. 13 Switching Time Test Circuit and Waveform

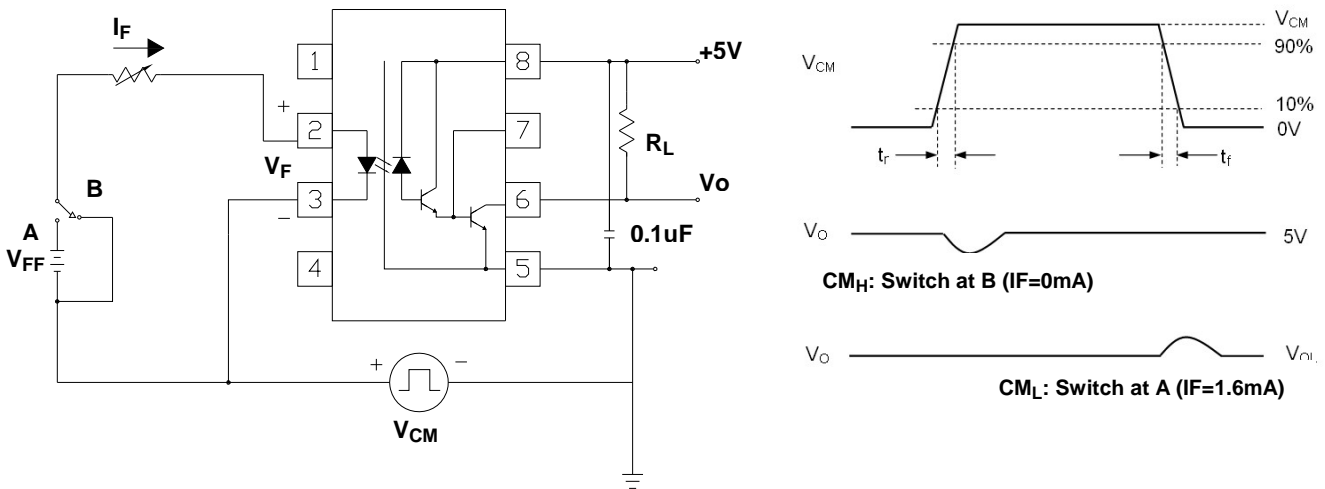

Fig. 14 Common Mode Transient Immunity Test Circuit and Waveform

Note:

*3 Common mode transient immunity in logic high level is the maximum tolerable (positive) dV_{cm}/dt on the leading edge of the common mode pulse signal V_{cm} , to assure that the output will remain in a logic high state (i.e., $V_O > 2.0V$).

Common mode transient immunity in logic low level is the maximum tolerable (negative) dV_{cm}/dt on the trailing edge of the common mode pulse signal, V_{cm} , to assure that the output will remain in a logic low state (i.e., $V_O < 0.8V$).



LIGHTING FOREVER

8 PIN DIP LOW INPUT CURRENT HIGH GAIN SPLIT DARLINGTON PHOTOCOUPLER

6N138 6N139

Order Information

Part Number

6N13XY(Z)-V

Note

- X = Part No. (X = 8 or 9)
- Y = Lead form option (S, S1, M or none)
- Z = Tape and reel option (TA, TB or none).
- V = VDE (optional)

Option	Description	Packing quantity
None	Standard DIP-8	45 units per tube
M	Wide lead bend (0.4 inch spacing)	45 units per tube
S (TA)	Surface mount lead form + TA tape & reel option	1000 units per reel
S (TB)	Surface mount lead form + TB tape & reel option	1000 units per reel
S1 (TA)	Surface mount lead form (low profile) + TA tape & reel option	1000 units per reel
S1 (TB)	Surface mount lead form (low profile) + TB tape & reel option	1000 units per reel

**8 PIN DIP LOW INPUT CURRENT HIGH GAIN
SPLIT DARLINGTON PHOTOCOUPLER**

6N138 6N139

**Package Drawing
(Dimensions in mm)**

Standard DIP Type

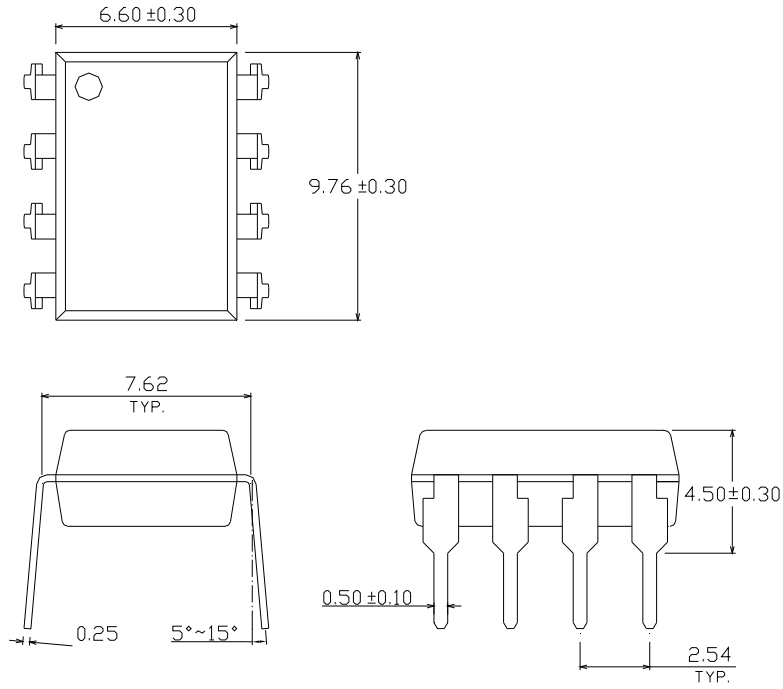

Option M Type

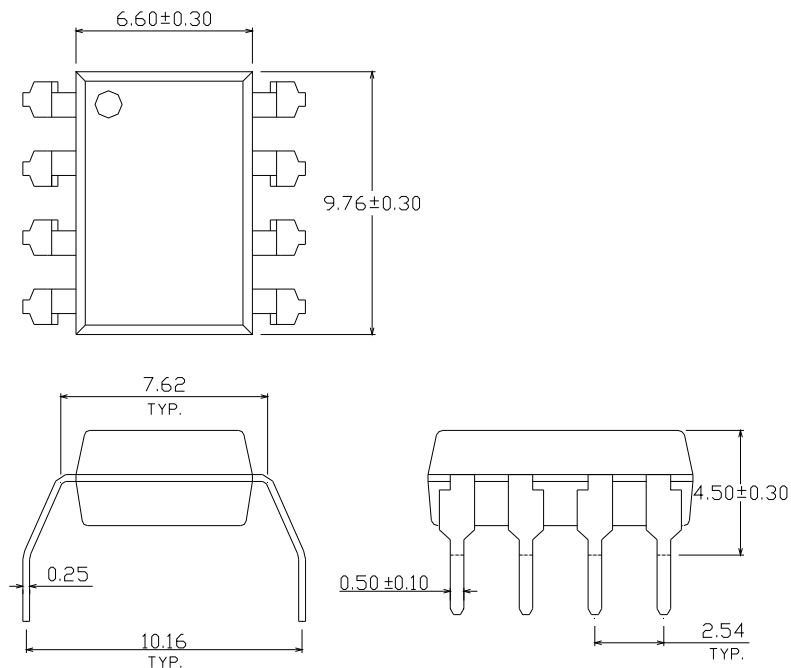

**8 PIN DIP LOW INPUT CURRENT HIGH GAIN
SPLIT DARLINGTON PHOTOCOUPLER**

6N138 6N139

Option S Type

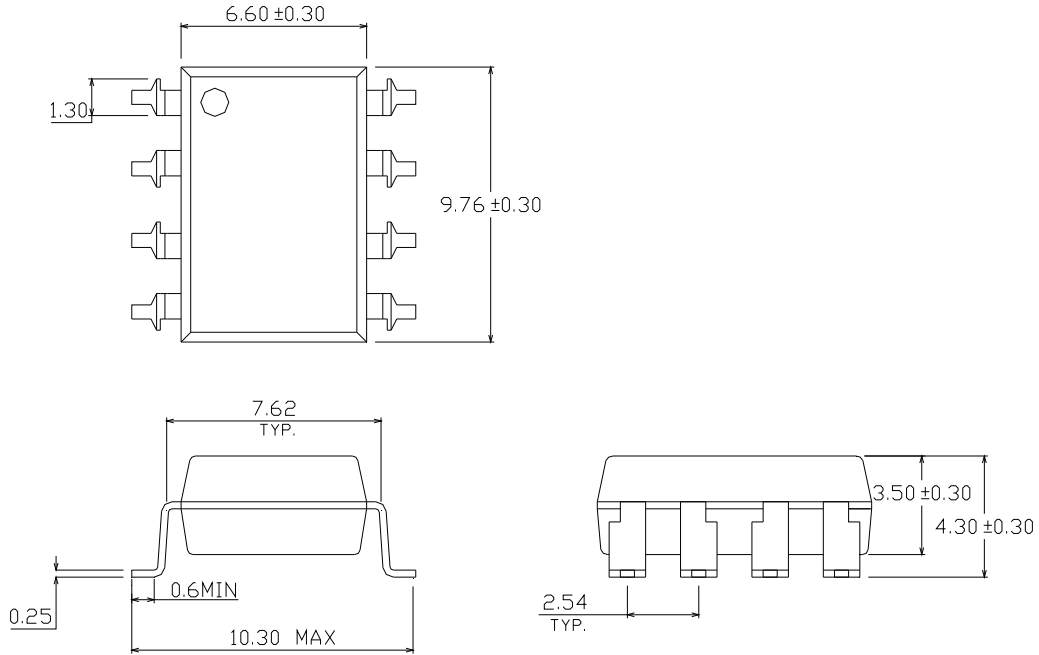

Option S1 Type

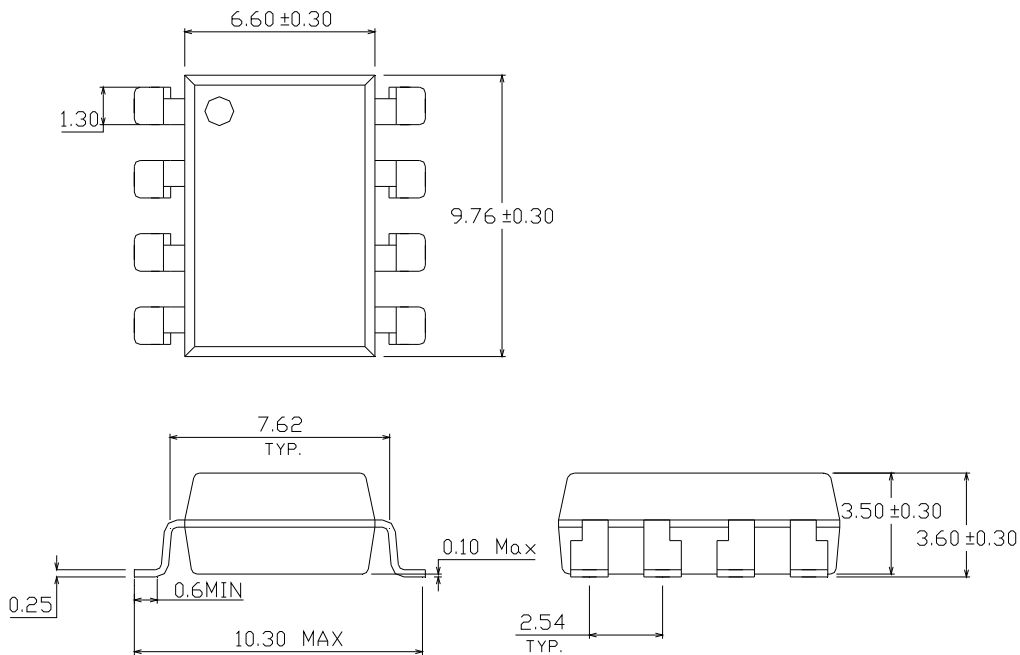

**8 PIN DIP LOW INPUT CURRENT HIGH GAIN
SPLIT DARLINGTON PHOTOCOUPLER**

6N138 6N139

Recommended pad layout for surface mount leadform

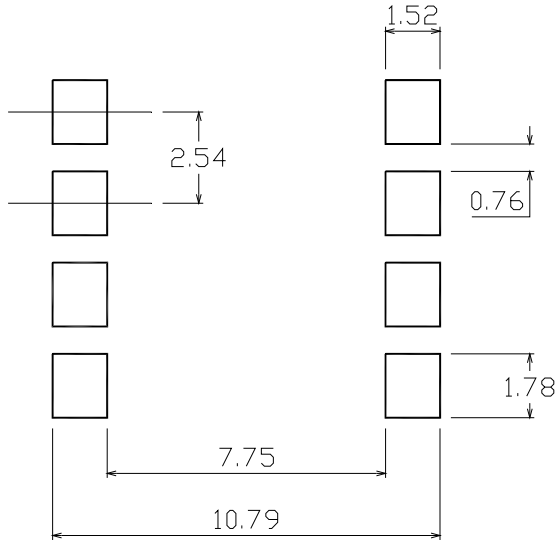

Device Marking

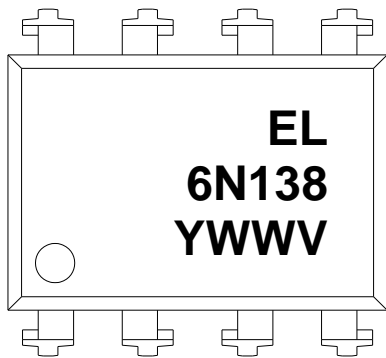

Notes

- 6N138 denotes Device Number
- Y denotes 1 digit Year code
- WW denotes 2 digit Week code
- V denotes VDE (Optional)

8 PIN DIP LOW INPUT CURRENT HIGH GAIN SPLIT DARLINGTON PHOTOCOUPLER

6N138 6N139

Tape & Reel Packing Specifications

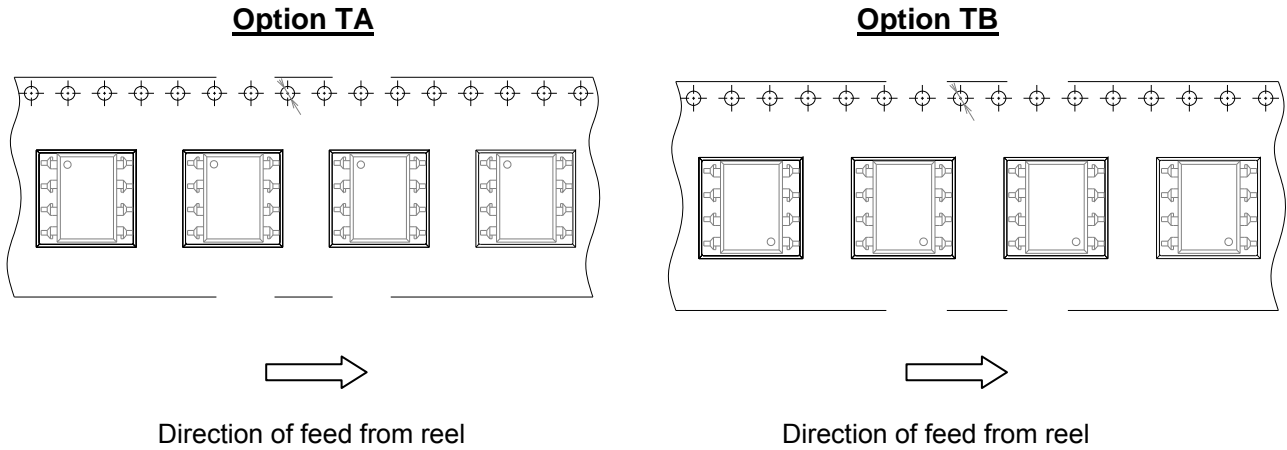

Tape dimensions

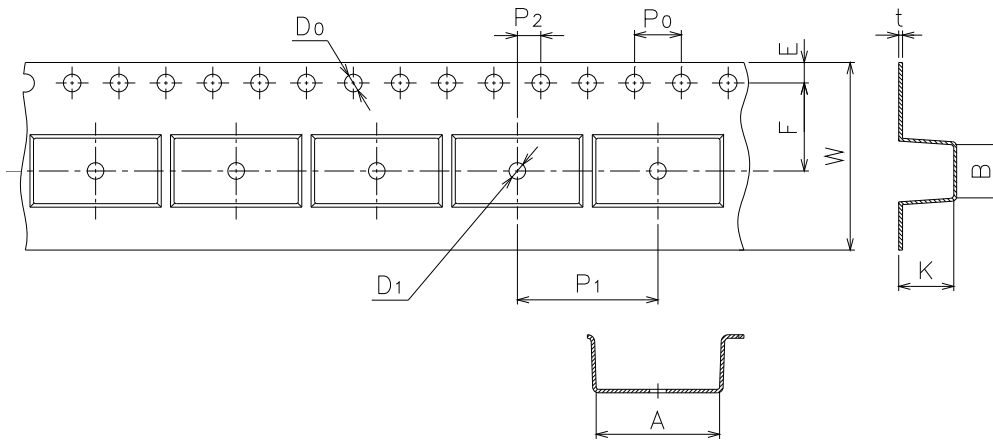

Dimension No.	A	B	Do	D1	E	F
Dimension(mm)	10.4±0.1	10.0±0.1	1.5±0.1	1.5±0.1	1.75±0.1	7.5±0.1
Dimension No.	Po	P1	P2	t	W	K
Dimension(mm)	4.0±0.1	12.0±0.1	2.0±0.1	0.4±0.1	16.0+0.3/ -0.1	4.5±0.1

**8 PIN DIP LOW INPUT CURRENT HIGH GAIN
SPLIT DARLINGTON PHOTOCOUPLER**

6N138 6N139

Solder Reflow Temperature Profile

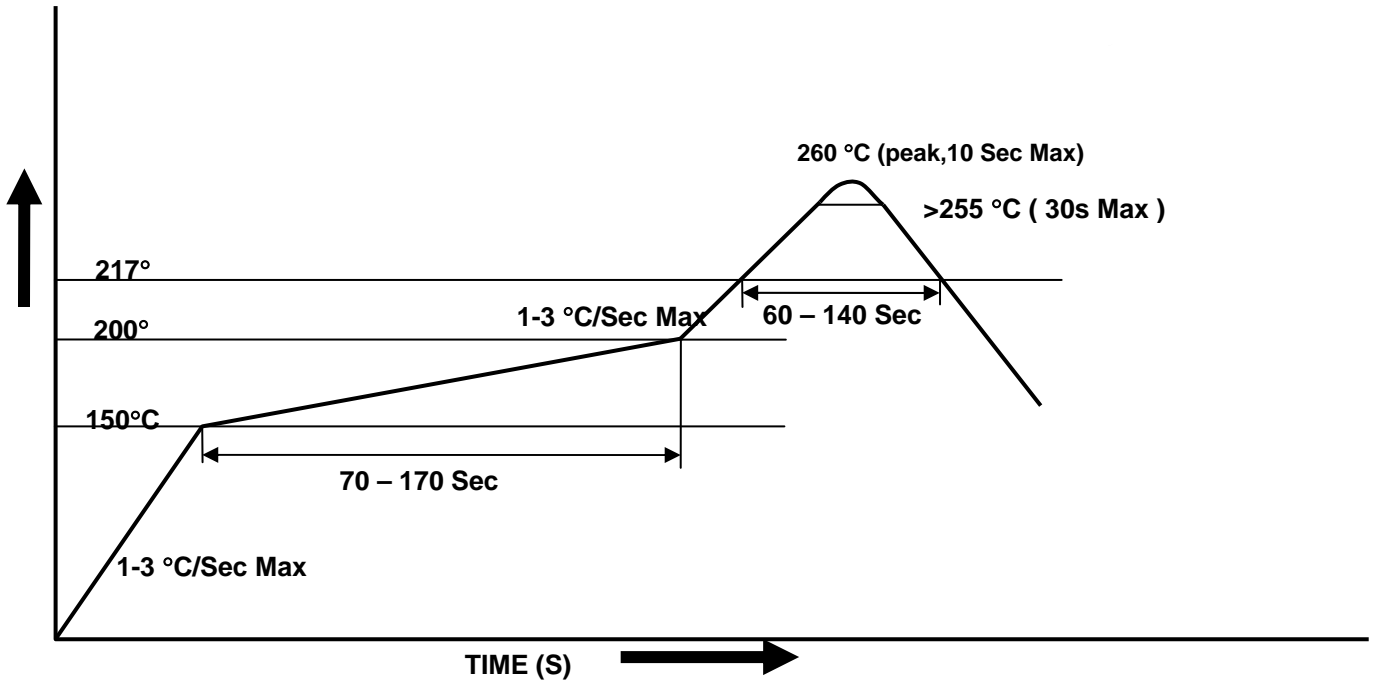



LIGHTING FOREVER

8 PIN DIP LOW INPUT CURRENT HIGH GAIN SPLIT DARLINGTON PHOTOCOUPLER

6N138 6N139

DISCLAIMER

1. Above specification may be changed without notice. EVERLIGHT will reserve authority on material change for above specification.
2. When using this product, please observe the absolute maximum ratings and the instructions for using outlined in these specification sheets. EVERLIGHT assumes no responsibility for any damage resulting from use of the product which does not comply with the absolute maximum ratings and the instructions included in these specification sheets.
3. These specification sheets include materials protected under copyright of EVERLIGHT corporation. Please don't reproduce or cause anyone to reproduce them without EVERLIGHT's consent.



Компания «ЭлектроПласт» предлагает заключение долгосрочных отношений при поставках импортных электронных компонентов на взаимовыгодных условиях!

Наши преимущества:

- Оперативные поставки широкого спектра электронных компонентов отечественного и импортного производства напрямую от производителей и с крупнейших мировых складов;
- Поставка более 17-ти миллионов наименований электронных компонентов;
- Поставка сложных, дефицитных, либо снятых с производства позиций;
- Оперативные сроки поставки под заказ (от 5 рабочих дней);
- Экспресс доставка в любую точку России;
- Техническая поддержка проекта, помощь в подборе аналогов, поставка прототипов;
- Система менеджмента качества сертифицирована по Международному стандарту ISO 9001;
- Лицензия ФСБ на осуществление работ с использованием сведений, составляющих государственную тайну;
- Поставка специализированных компонентов (Xilinx, Altera, Analog Devices, Intersil, Interpoint, Microsemi, Aeroflex, Peregrine, Syfer, Eurofarad, Texas Instrument, Miteq, Cobham, E2V, MA-COM, Hittite, Mini-Circuits, General Dynamics и др.);

Помимо этого, одним из направлений компании «ЭлектроПласт» является направление «Источники питания». Мы предлагаем Вам помощь Конструкторского отдела:

- Подбор оптимального решения, техническое обоснование при выборе компонента;
- Подбор аналогов;
- Консультации по применению компонента;
- Поставка образцов и прототипов;
- Техническая поддержка проекта;
- Защита от снятия компонента с производства.



Как с нами связаться

Телефон: 8 (812) 309 58 32 (многоканальный)

Факс: 8 (812) 320-02-42

Электронная почта: org@eplast1.ru

Адрес: 198099, г. Санкт-Петербург, ул. Калинина, дом 2, корпус 4, литера А.