

## Automotive 2-line ESD protection for high speed lines

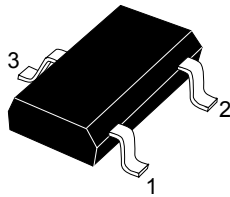

**SOT323-3L**  
(Jedec TO-236)

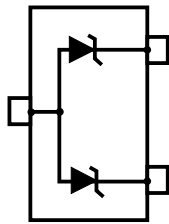

Functional diagram

### Features

- AEC-Q101 qualified 
- Flow-through routing to keep signal integrity
- Ultra large bandwidth: 3 GHz
- Ultra low capacitance: 0.7 pF
- Extended operating junction temperature range: -40 °C to 150 °C
- RoHS compliant
- Complies with ISO 10605 - C = 150 pF, R = 330 Ω exceeds level 4
  - ±12 kV (contact discharge)
  - ±15 kV (air discharge)
- Complies with ISO 10605 - C = 330 pF, R = 330 Ω
  - ±8 kV (contact discharge)
  - ±12 kV (air discharge)

### Application

The **HSP051-2W3Y** is designed to protect against electrostatic discharge on automotive circuits such as:

- APIX
- LVDS & digital video interface
- Ethernet and BroadReach
- USB 2.0 and USB 3.0
- High speed communication buses

### Description

The **HSP051-2W3Y** is an ESD array designed for high-speed differential lines protection.

The ultralow capacitance variation ensures negligible influence on signal-skew.

Product status link	
<a href="#">HSP051-2W3Y</a>	
Product summary	
<b>Order code</b>	HSP051-2W3Y
<b>Marking</b>	H5Y
<b>Package</b>	SOT323-3L
<b>Packing</b>	Tape and reel

# 1 Characteristics

**Table 1. Absolute maximum ratings (T<sub>amb</sub> = 25 °C)**

Symbol	Parameter	Value	Unit	
V <sub>PP</sub>	Peak pulse voltage	ISO10605 / IEC 61000-4-2 (C = 150 pF, R = 330 Ω):		
		Contact discharge	12	kV
		Air discharge	15	
		ISO10605 (C = 330 pF, R = 330 Ω)		
Contact discharge	8			
	Air discharge	12		
P <sub>PP</sub>	Peak pulse power dissipation (8/20 μs)	20	W	
I <sub>PP</sub>	Peak Pulse current (8/20 μs)	1.8	A	
T <sub>stg</sub>	Storage temperature range	-65 to +150	°C	
T <sub>j</sub>	Operating junction temperature range	-40 to +150	°C	
T <sub>L</sub>	Maximum lead temperature for soldering during 10 s	260	°C	

**Figure 1. Electrical characteristics - parameter definitions**

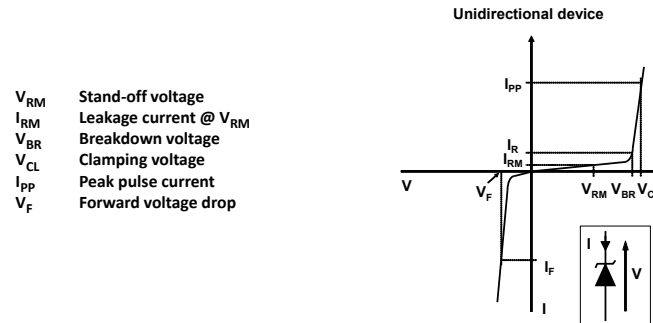

**Table 2. Electrical characteristics (values) (T<sub>amb</sub> = 25° C)**

Symbol	Test conditions	Min.	Typ.	Max.	Unit
V <sub>BR</sub>	I <sub>R</sub> = 1 mA	5.3			V
I <sub>R</sub>	V <sub>R</sub> = 3 V			100	nA
	V <sub>R</sub> = 5 V			150	
V <sub>CL</sub>	ISO 10605- C = 150 pF, R = 330 Ω +8 kV contact discharge, measured at 30 ns		18		V
C <sub>I/O-GND</sub>	V <sub>I/O</sub> = 0 V, f = 1 MHz, V <sub>OSC</sub> = 30 mV		0.7	1.0	pF
ΔC <sub>I/O-GND</sub>			0.03		
f <sub>C</sub>	S <sub>21</sub> = -3 dB		3		GHz

## 1.1 Characteristics (curves)

Figure 2. Leakage current versus junction temperature

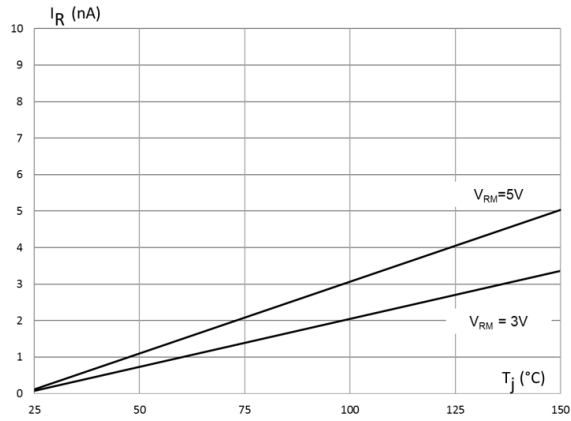

Figure 3. Junction capacitance versus reverse applied voltage

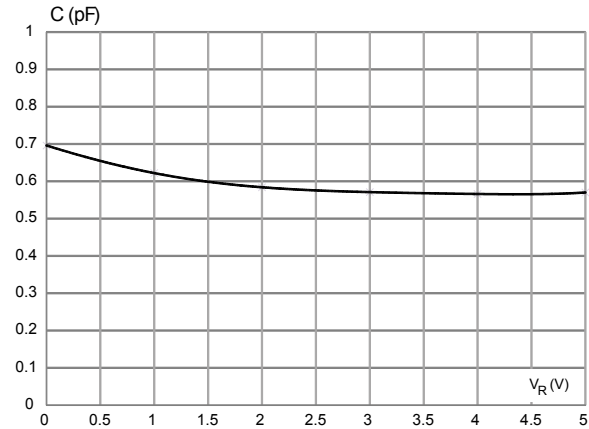

Figure 4. ESD response to ISO 10605 - C = 150 pF, R = 330  $\Omega$  (+8 kV contact discharge)



Figure 5. ESD response to ISO 10605 - C = 150 pF, R = 330  $\Omega$  (-8 kV contact discharge)



Figure 6. TLP

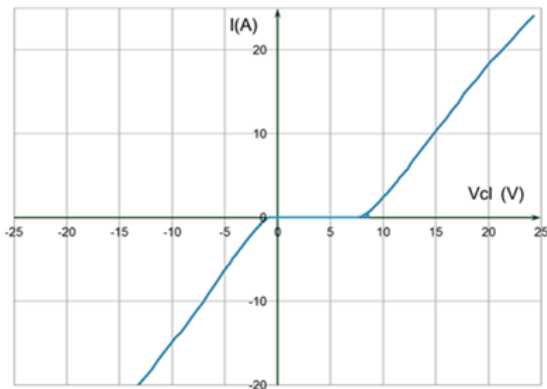
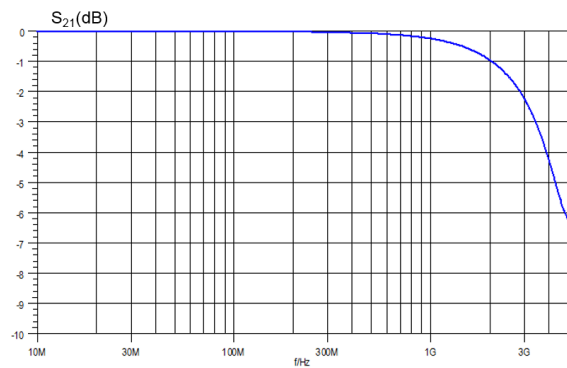
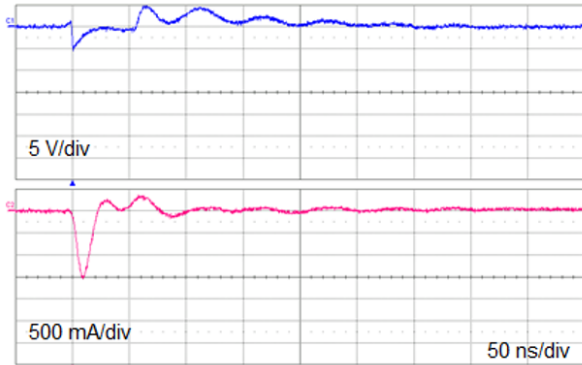

Figure 7. S<sub>21</sub> attenuation



**Figure 8. Fast transient pulse 3a ( $U_s = -150\text{ V}$ )**



**Figure 9. Fast transient pulse 3b ( $U_s = +150\text{ V}$ )**

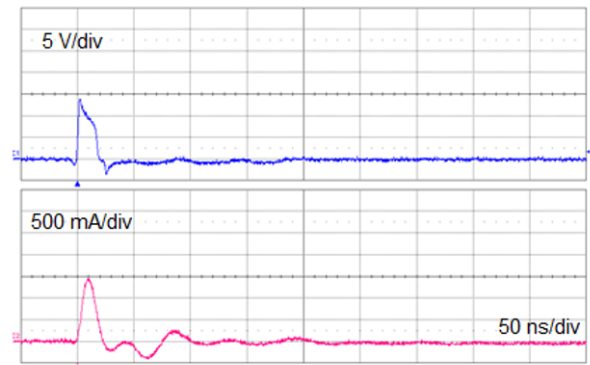

**Figure 10. Slow transient pulse - negative 2a ( $U_s = -85\text{ V}$ )**

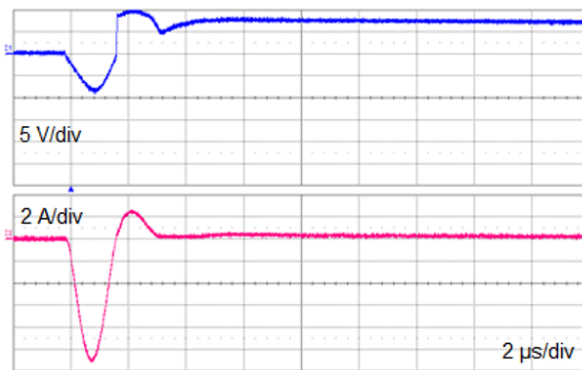

**Figure 11. Slow transient pulse - positive 2a ( $U_s = +85\text{ V}$ )**

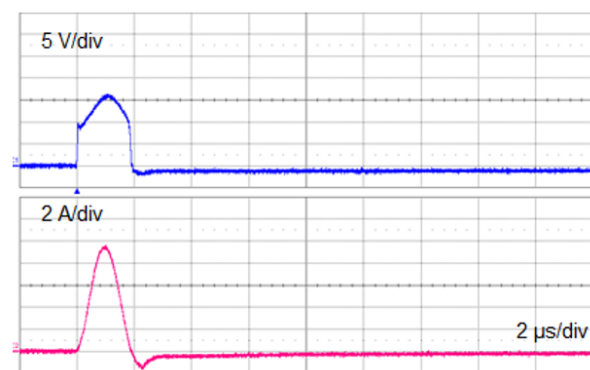

## 2 Package information

In order to meet environmental requirements, ST offers these devices in different grades of ECOPACK® packages, depending on their level of environmental compliance. ECOPACK® specifications, grade definitions and product status are available at: [www.st.com](http://www.st.com). ECOPACK® is an ST trademark.

### 2.1 SOT323-3L package information

- Epoxy meets UL 94,V0
- Lead-free package

Figure 12. SOT323-3L package outline

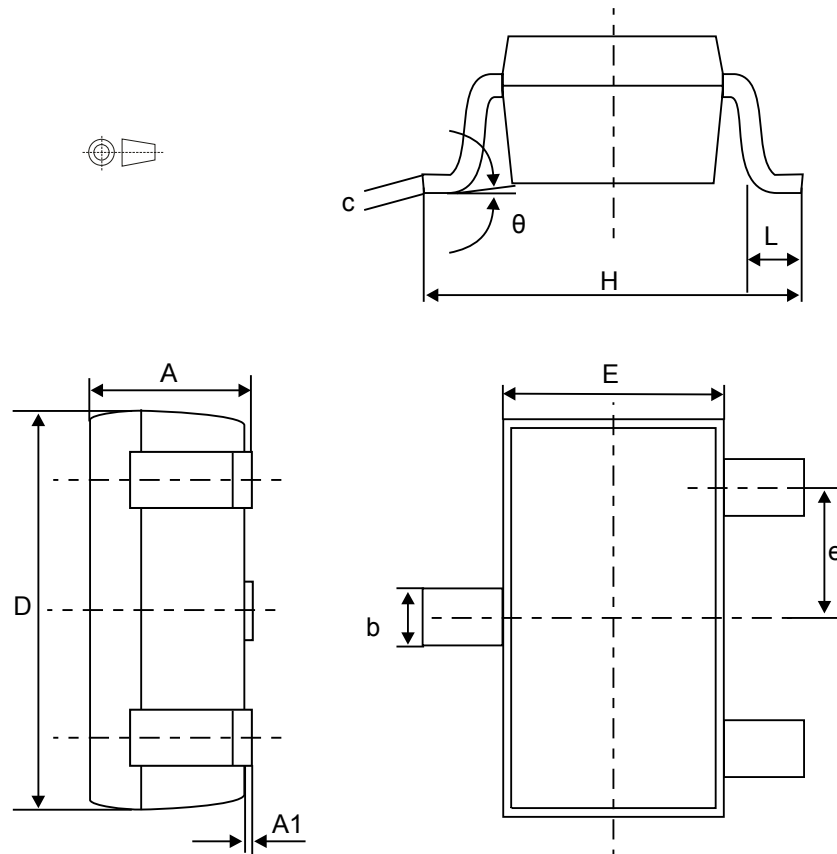

Table 3. SOT323-3L package mechanical data

Ref.	Dimensions					
	Millimeters			Inches <sup>(1)</sup>		
	Min.	Typ.	Max.	Min.	Typ.	Max.
A	0.8		1.1	0.031		0.043
A1	0.0		0.1	0.000		0.003
b	0.25		0.4	0.0098		0.0157
c	0.1		0.26	0.003		0.0102
D	1.8	2.0	2.2	0.070	0.078	0.086
E	1.15	1.25	1.35	0.0452	0.0492	0.0531
e	0.60	0.65	0.70	0.024	0.026	0.028
H	1.8	2.1	2.4	0.070	0.082	0.094
L	0.1	0.2	0.30	0.004	0.008	0.012
Θ		0	30°	0		30°

1. Values in inches are converted from mm and rounded to 3 decimal digits

Figure 13. SOT323-3L recommended footprint (dimensions in inches)

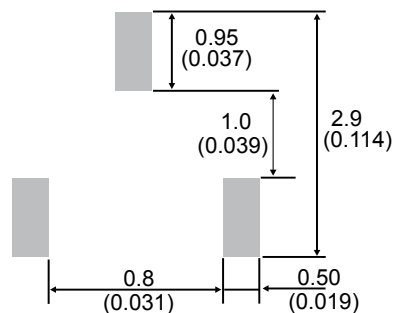
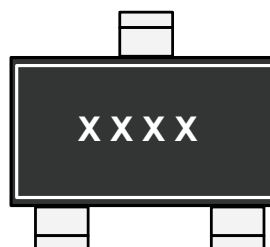
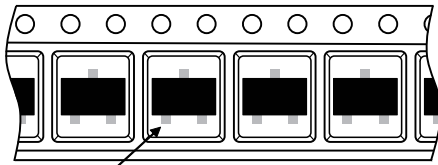

Figure 14. SOT323-3L marking



XXXX : Marking

**Figure 15. Package orientation in reel**



Pin 1 located according to EIA-481

Note: Pocket dimensions are not on scale  
Pocket shape may vary depending on package

**Figure 16. Tape and reel orientation**

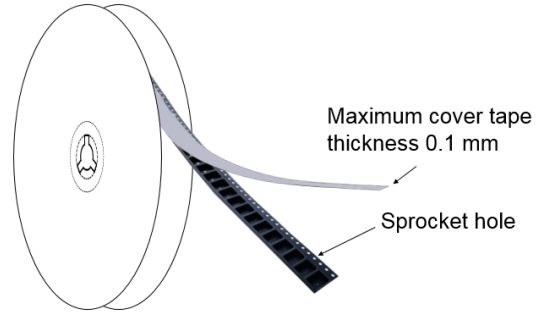

Maximum cover tape thickness 0.1 mm

Sprocket hole

**Figure 17. 7" reel dimension values**

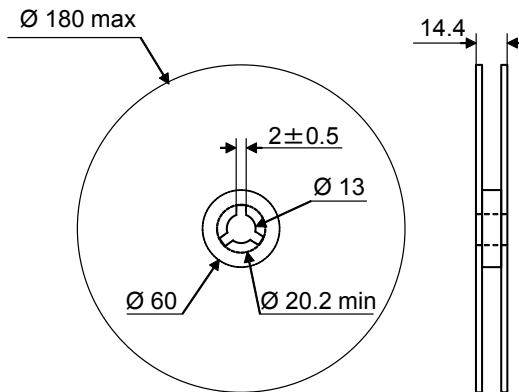

**Figure 18. Inner box dimension values**

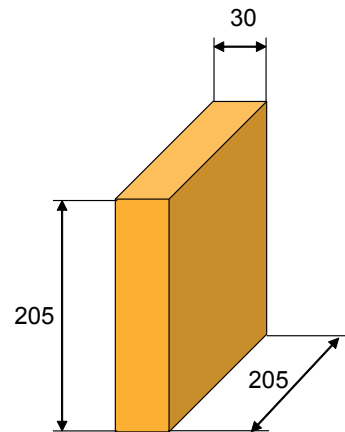

**Figure 19. Tape outline**

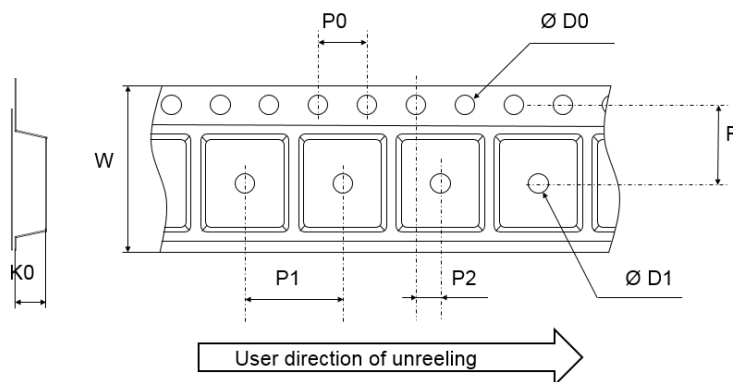

Note: Pocket dimensions are not on scale  
Pocket shape may vary depending on package

**Table 4. Tape dimension values**

Ref.	Dimensions		
	Millimeters		
	Min.	Typ.	Max.
D0	1.45	1.5	1.6
D1	1		
F	3.45	3.5	3.55
K0	1.3	1.4	1.5
P0	3.9	4.0	4.1
P1	3.9	4.0	4.1
P2	1.95	2.0	2.05
W	7.9	8	8.3



### 3 Recommendation on PCB assembly

#### 3.1 Reflow profile

Figure 20. ST ECOPACK® recommended soldering reflow profile for PCB mounting

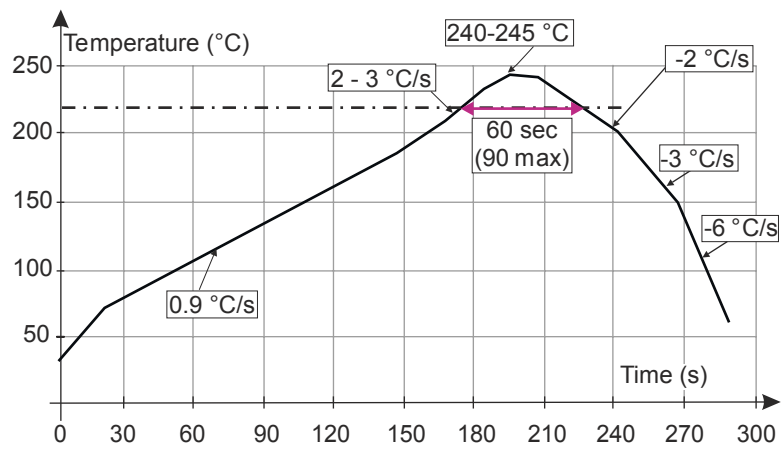

Note: Minimize air convection currents in the reflow oven to avoid component movement.

## 4 Ordering information

Figure 21. Ordering information scheme

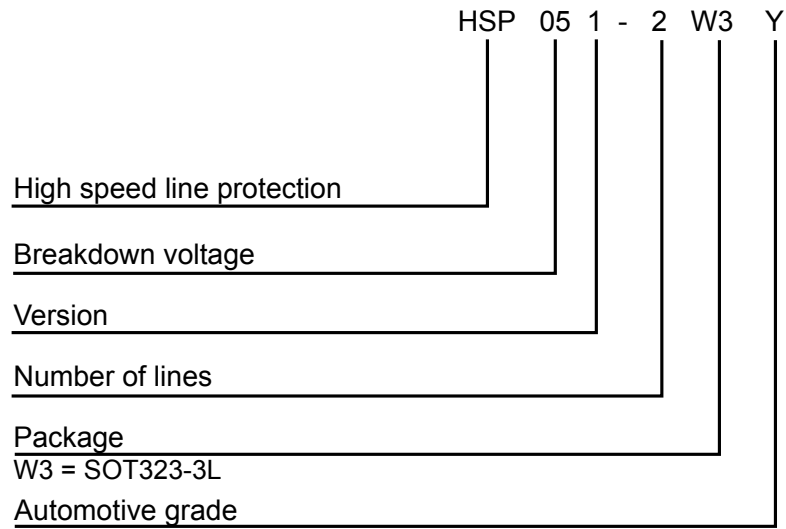

Table 5. Ordering information

Order code	Marking <sup>(1)</sup>	Package	Weight	Base qty.	Delivery mode
HSP051-2W3Y	H5Y	SOT323-3L	6 mg	3000	Tape and reel

1. The marking can be rotated by multiples of 90° to differentiate assembly location

## Revision history

**Table 6. Document revision history**

Date	Version	Changes
10-Jul-2018	1	Initial release.

**IMPORTANT NOTICE – PLEASE READ CAREFULLY**

STMicroelectronics NV and its subsidiaries (“ST”) reserve the right to make changes, corrections, enhancements, modifications, and improvements to ST products and/or to this document at any time without notice. Purchasers should obtain the latest relevant information on ST products before placing orders. ST products are sold pursuant to ST’s terms and conditions of sale in place at the time of order acknowledgement.

Purchasers are solely responsible for the choice, selection, and use of ST products and ST assumes no liability for application assistance or the design of Purchasers’ products.

No license, express or implied, to any intellectual property right is granted by ST herein.

Resale of ST products with provisions different from the information set forth herein shall void any warranty granted by ST for such product.

ST and the ST logo are trademarks of ST. All other product or service names are the property of their respective owners.

Information in this document supersedes and replaces information previously supplied in any prior versions of this document.

© 2018 STMicroelectronics – All rights reserved



Компания «ЭлектроПласт» предлагает заключение долгосрочных отношений при поставках импортных электронных компонентов на взаимовыгодных условиях!

Наши преимущества:

- Оперативные поставки широкого спектра электронных компонентов отечественного и импортного производства напрямую от производителей и с крупнейших мировых складов;
- Поставка более 17-ти миллионов наименований электронных компонентов;
- Поставка сложных, дефицитных, либо снятых с производства позиций;
- Оперативные сроки поставки под заказ (от 5 рабочих дней);
- Экспресс доставка в любую точку России;
- Техническая поддержка проекта, помощь в подборе аналогов, поставка прототипов;
- Система менеджмента качества сертифицирована по Международному стандарту ISO 9001;
- Лицензия ФСБ на осуществление работ с использованием сведений, составляющих государственную тайну;
- Поставка специализированных компонентов (Xilinx, Altera, Analog Devices, Intersil, Interpoint, Microsemi, Aeroflex, Peregrine, Syfer, Eurofarad, Texas Instrument, Miteq, Cobham, E2V, MA-COM, Hittite, Mini-Circuits, General Dynamics и др.);

Помимо этого, одним из направлений компании «ЭлектроПласт» является направление «Источники питания». Мы предлагаем Вам помощь Конструкторского отдела:

- Подбор оптимального решения, техническое обоснование при выборе компонента;
- Подбор аналогов;
- Консультации по применению компонента;
- Поставка образцов и прототипов;
- Техническая поддержка проекта;
- Защита от снятия компонента с производства.



#### Как с нами связаться

**Телефон:** 8 (812) 309 58 32 (многоканальный)

**Факс:** 8 (812) 320-02-42

**Электронная почта:** [org@eplast1.ru](mailto:org@eplast1.ru)

**Адрес:** 198099, г. Санкт-Петербург, ул. Калинина, дом 2, корпус 4, литера А.