

3G3MX2 AC Drives

Born to drive machines



» Omron Quality with a capital "Q"

» High programming functionality

» Built-in safety

Harmonized motor and machine control

The 3G3MX2 is specifically designed to drive machines. It has been developed to harmonize advanced motor and machine control.

Thanks to its advanced design and algorithms the 3G3MX2 provides smooth control down to zero speed, plus precise operation for fast cyclic operations and torque control capability in open loop.

The 3G3MX2 also gives you comprehensive functionality for machine control such as positioning, speed synchronization and logic programming. The 3G3MX2 is fully integrated within the Omron smart automation platform. The 3G3MX2 is the child of a true leader in machine automation.

MOTOR CONTROL

200% starting torque

- Near stand-still operation (0.5 Hz)
- Smooth control of high inertia loads
- Control of fast cyclic loads

Torque control in open loop

- Ideal for low to medium torque applications
- Can replace a flux vector or servo drive in suitable systems

Special motors

- Permanent magnet motors
- High speed motors up to 1000 Hz

One parameter auto-tuning

- Just by entering the power rating of the motor the 3G3MX2 gives you smooth and safe operation





MACHINE CONTROL

Safety inside

- Conforms to safety norm ISO-13849-1 Cat 3 performance level D
- 2 Safety inputs
- External device monitoring (EDM)

Logic programming

- Flow chart programming
- Intuitive – up to 5 tasks in parallel

Positioning

- Up to 8 pre-set positions with “Homing”
- Speed synchronization

Integrated in the Omron Smart Automation

- CX-Drive programming tool connected via integrated USB port on 3G3MX2.
- Modbus RS485 built-in
- Option units for EtherCAT, Profibus, DeviceNet, ML-II, EtherNet/IP and more...

100% Control...

High starting torque and torque control capability in open loop mode gives you full control of your machine dynamics and performance. Options for all of the major fieldbus systems and a 24 VDC external supply keeps you in full control of your machine operation.



Torque master

The 3G3MX2 delivers 200% starting torque near stand-still (0.5 Hz) and can operate in torque control in open loop mode. This allows the 3G3MX2 to be used in applications where closed loop AC vector drives were previously used.



Easy network integration

Built-in RS485 Modbus communications and the possibility for integration in standard industrial networks, such as DeviceNet, Profibus, EtherNet/IP, CompoNet, ML-II or EtherCat makes the 3G3MX2 exceptionally easy to integrate.



External 24 VDC for continuous operation

With no additional hardware, a 24 VDC connection to the 3G3MX2 ensures the CPU is always in control, even if the main input is removed. This feature is vital in providing a controlled stop in emergency situations and in keeping the network communications operating.

...0% risk!

Safety is embedded in the 3G3MX2, according to ISO 13849-1, Cat 3, with two safety inputs and an External Device Monitoring (EDM) output. No external contactors on the motor side are required, meaning simpler wiring for the user.

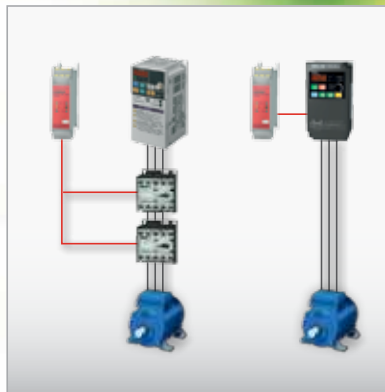

Safety embedded; ISO 13849-1, Cat 3

Dual contactors at the output of the Drive are no longer required. Direct connection to a safety controller ensures compliance to ISO 13849-1, Cat 3.

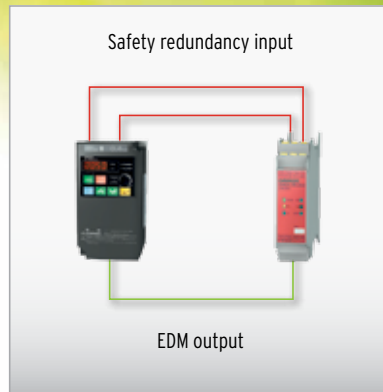

EDM monitoring output

An External Device Monitoring (EDM) output confirms the safety status of the Drive, saving you the cost and wiring of external devices to carry out the same function.

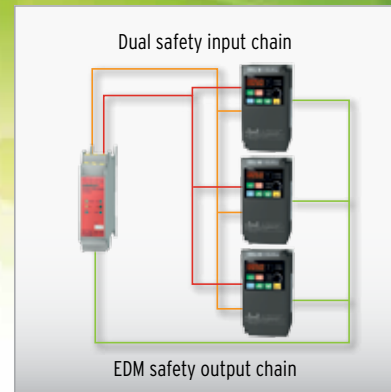

Direct integration into the safety circuit

3G3MX2 Drives can fit easily into the safety circuit. The safety inputs can be linked from one drive to another without additional safety relays.

Position and run!

The 3G3MX2 is a drive and position controller in one, ideal for modular machines where moderate positional accuracy is required. Speed synchronization is also possible, with no additional programming required.



Speed synchronization

With no external hardware required, and via standard parameter settings, speed synchronization can be achieved. The 3G3MX2 will act as a speed follower to an external pulse generator/ encoder signal up to 32 kHz.



Positioning functionality

Specially developed application functionality enables the 3G3MX2 to solve simple positioning tasks without the need for an external controller. Up to 8 positions, plus home, can be selected by the user, and furthermore, the 3G3MX2 can be switched between speed and position mode.

Program and play!

The 3G3MX2 gives you the power to create smart solutions using PLC functionality, as standard. Via an intuitive flow chart programming tool, you can create programs with up to 1000 lines of code and with 5 tasks running in parallel.

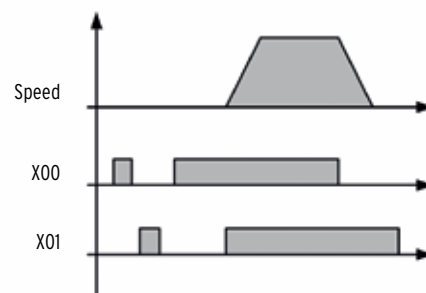

Free to program

- Intuitive and user friendly flow chart programming
- Integrated in CX-Drive
- Up to 1000 lines in a program
- 5 tasks can run in parallel

3G3MX2

Born to drive machines

- Current vector control
- High starting torque: 200% at 0.5Hz
- Double rating VT 120% for 1min and CT 150% for 1min
- Speed range up to 1000 Hz
- Induction motor & permanent magnet motor control
- Torque control in open loop vector
- Positioning functionality
- Built-in application functionality (i.e., Brake control)
- User programmable as standard
- Safety embedded compliant with ISO13849-1 (double input circuit and external device monitor EDM)
- USB port for PC programming
- 24 VDC backup supply for control board
- Fieldbus communications: Modbus, EtherNet/IP, DeviceNet, Profibus, Comconet, EtherCAT, and ML-II
- PC configuration tool: CX-Drive
- RoHS, CE, cULus

Ratings

- 200 V Class single-phase 0.1 to 2.2 kW (1/8 to 3 HP)
- 200 V Class three-phase 0.1 to 15.0 kW (1/8 to 20 HP)
- 400 V Class three-phase 0.4 to 15.0 kW (1/2 to 20 HP)



System Configuration



Specifications

Type Designation

3 G 3 M X 2 A B 0 0 1

3G3MX2 series

A: Standard specs

Voltage:
B: Single-phase 200 VAC
2: Three-phase 200 VAC
4: Three-phase 400 VAC

Max. applicable motor output
001: 0.1 kW (1/8 HP)
to
150: 15.0 kW (20 HP)

200 V class

| Single-phase 3G3MX2-□ | | | AB001 | AB002 | AB004 | AB007 ¹ | AB015 | AB022 | - | - | - | - | - |
|--|---|---------|---|-------|-------|--------------------|--------------------------|-------|-------------|-------|-------|-------|-------|
| Three-phase 3G3MX2-□ | | | A2001 | A2002 | A2004 | A2007 | A2015 | A2022 | A2037 | A2055 | A2075 | A2110 | A2150 |
| Applicable motor capacity ² | kW | CT | 0.1 | 0.2 | 0.4 | 0.75 | 1.5 | 2.2 | 3.7 | 5.5 | 7.5 | 11.0 | 15.0 |
| | | VT | 0.2 | 0.4 | 0.55 | 1.1 | 2.2 | 3.0 | 5.5 | 7.5 | 11.0 | 15.0 | 18.5 |
| | HP | CT | 1/8 | 1/4 | 1/2 | 1.0 | 2.0 | 3.0 | 5.0 | 7 1/2 | 10.0 | 15.0 | 20.0 |
| | | VT | 1/4 | 1/2 | 3/4 | 1 1/2 | 3.0 | 4.0 | 7 1/2 | 10.0 | 15.0 | 20.0 | 25.0 |
| Output characteristics | Drive capacity kVA | 200 VT | 0.4 | 0.6 | 1.2 | 2.0 | 3.3 | 4.1 | 6.7 | 10.3 | 13.8 | 19.3 | 23.9 |
| | | 200 CT | 0.2 | 0.5 | 1.0 | 1.7 | 2.7 | 3.8 | 6.0 | 8.6 | 11.4 | 16.2 | 20.7 |
| | | 240 VT | 0.4 | 0.7 | 1.4 | 2.4 | 3.9 | 4.9 | 8.1 | 12.4 | 16.6 | 23.2 | 28.6 |
| | | 240 CT | 0.3 | 0.6 | 1.2 | 2.0 | 3.3 | 4.5 | 7.2 | 10.3 | 13.7 | 19.5 | 24.9 |
| | Rated output current (A) at VT | | 1.2 | 1.9 | 3.5 | 6.0 | 9.6 | 12.0 | 19.6 | 30.0 | 40.0 | 56.0 | 69.0 |
| | Rated output current (A) at CT | | 1.0 | 1.6 | 3.0 | 5.0 | 8.0 | 11.0 | 17.5 | 25.0 | 33.0 | 47.0 | 60.0 |
| | Max. output voltage | | Proportional to input voltage: 0 to 240 V | | | | | | | | | | |
| Max. output frequency | | 1000 Hz | | | | | | | | | | | |
| Power supply | Rated input voltage and frequency | | Single-phase 200 to 240 V 50/60 Hz 3-phase 200 to 240 V 50/60 Hz | | | | | | | | | | |
| | Allowable voltage fluctuation | | -15% to +10% | | | | | | | | | | |
| | Allowable frequency fluctuation | | 5% | | | | | | | | | | |
| Braking torque | At short-time deceleration At capacitor feedback | | 100%: <50Hz 50%: <60Hz | | | | 70%: <50Hz 50%: <60Hz | | Approx. 20% | | - | | |
| | Cooling method | | Self cooling | | | | Forced-air-cooling | | | | | | |

Note: 1. Three phase model use forced-air-cooling but single phase model is self cooling.
2. Based on a standard 3-Phase standard motor.
3. Above 400Hz with some function limitation.

400 V class

| Three-phase 3G3MX2-□ | | | A4004 | A4007 | A4015 | A4022 | A4030 | A4040 | A4055 | A4075 | A4110 | A4150 | |
|--|---|---|-------------------------------|-------|-------|-------|--------------------------|-------|-------|-------|-------|-------|--|
| Applicable motor capacity ¹ | kW | CT | 0.4 | 0.75 | 1.5 | 2.2 | 3.0 | 4.0 | 5.5 | 7.5 | 11.0 | 15.0 | |
| | | VT | 0.75 | 1.5 | 2.2 | 3.0 | 4.0 | 5.5 | 7.5 | 11.0 | 15.0 | 18.5 | |
| | HP | CT | 1/2 | 1.0 | 2.0 | 3.0 | 4.0 | 5.0 | 7 1/2 | 10.0 | 15.0 | 20.0 | |
| | | VT | 1.0 | 2.0 | 3.0 | 4.0 | 5.0 | 7 1/2 | 10.0 | 15.0 | 20.0 | 25.0 | |
| Output characteristics | Drive capacity kVA | 380 VT | 1.3 | 2.6 | 3.5 | 4.5 | 5.7 | 7.3 | 11.5 | 15.1 | 20.4 | 25.0 | |
| | | 380 CT | 1.1 | 2.2 | 3.1 | 3.6 | 4.7 | 6.0 | 9.7 | 11.8 | 15.7 | 20.4 | |
| | | 480 VT | 1.7 | 3.4 | 4.4 | 5.7 | 7.3 | 9.2 | 14.5 | 19.1 | 25.7 | 31.5 | |
| | | 480 CT | 1.4 | 2.8 | 3.9 | 4.5 | 5.9 | 7.6 | 12.3 | 14.9 | 19.9 | 25.7 | |
| | Rated output current (A) at VT | | 2.1 | 4.1 | 5.4 | 6.9 | 8.8 | 11.1 | 17.5 | 23.0 | 31.0 | 38.0 | |
| | Rated output current (A) at CT | | 1.8 | 3.4 | 4.8 | 5.5 | 7.2 | 9.2 | 14.8 | 18.0 | 24.0 | 31.0 | |
| Max. output voltage | | Proportional to input voltage: 0 to 480 V | | | | | | | | | | | |
| Max. output frequency | | 1000 Hz | | | | | | | | | | | |
| Power supply | Rated input voltage and frequency | | 3-phase 380 to 480 V 50/60 Hz | | | | | | | | | | |
| | Allowable voltage fluctuation | | -15% to +10% | | | | | | | | | | |
| | Allowable frequency fluctuation | | 5% | | | | | | | | | | |
| Braking torque | At short-time deceleration At capacitor feedback | | 100%: <50Hz 50%: <60Hz | | | | 70%: <50Hz 50%: <60Hz | | - | | - | | |
| | Cooling method | | Self cooling | | | | Forced-air-cooling | | | | | | |

Note: 1. Based on a standard 3-Phase standard motor.
2. Above 400Hz with some function limitation.

Specifications

Common specifications

| Model number 3G3MX2-□ | | Specifications | |
|------------------------|---|--|--|
| Control functions | Control methods | Phase-to-phase sinusoidal pulse with modulation PWM (Sensorless vector control, V/Hz) | |
| | Output frequency range | 0.10 to 1000.00 Hz (with restrictions above 400Hz) | |
| | Frequency precision | Digital set value: ±0.01% of the max. frequency | |
| | | Analog set value: ±0.2% of the max. frequency (25 ±10°C) | |
| | Resolution of frequency set value | Digital set value: 0.01 Hz | |
| | | Analog set value: 1/1000 of maximum frequency | |
| | Resolution of output frequency | 0.01 Hz | |
| | Starting torque | 200% at 0.5 Hz | |
| | Overload capability | Dual rating: Heavy duty (CT): 150% for 1 minute Normal Duty (VT): 120% for 1 minute | |
| Frequency set value | 0 to 10 VDC (10KΩ), 4 to 20mA (100Ω), RS485 Modbus, Network options | | |
| V/Hz Characteristics | Constant/ reduced torque, free V/Hz | | |
| Functionality | Inputs signals | FW (forward run command), RV (reverse run command), CF1~CF4 (multi-stage speed setting), JG (jog command), DB (external braking), SET (set second motor), 2CH (2-stage accel./decel. command), FRS (free run stop command), EXT (external trip), USP (startup function), CS (commercial power switchover), SFT (soft lock), AT (analog input selection), RS (reset), PTC (thermistor thermal protection), STA (start), STP (stop), F/R (forward/reverse), PID (PID disable), PIDC (PID reset), UP (remote control up function), DWN (remote control down function), UDC (remote control data clear), OPE (operator control), SF1~SF7 (multi-stage speed setting; bit operation), OLR (overload restriction), TL (torque limit enable), TRQ1 (torque limit changeover1), TRQ2 (torque limit changeover2), BOK (Braking confirmation), LAC (LAD cancellation), PCLR (position deviation clear), ADD (add frequency enable), F-TM (force terminal mode), ATR (permission of torque command input), KHC (Cumulative power clear), MI1~MI7 (general purpose inputs for EzSQ), AHD (analog command hold), CP1~CP3 (multistageposition switches), ORL (limit signal of zero-return), ORC (trigger signal of zero-return), SPD (speed/position changeover), GS1~GS2 (STO inputs, safety related signals), 485 (Starting communication signal), PRG (executing EzSQ program), HLD (retain output frequency), ROK (permission of run command), EB (rotation direction detection of B-phase), DISP (display limitation), OP (option control signal), NO (no function) | |
| | Output signals | RUN (run signal), FA1~FA5 (frequency arrival signal), OL,OL2 (overload advance notice signal), OD (PID deviation error signal), AL (alarm signal), OTQ (over/under torque threshold), UV (under-voltage), TRQ (torque limit signal), RNT (run time expired), ONT (power ON time expired), THM (thermal warning), BRK (brake release), BER (brake error), ZS (0Hz detection), DSE (speed deviation excessive), POK (positioning completion), ODc (analog voltage input disconnection), OIdc (analog current input disconnection), FBV (PID second stage output), NDc (network disconnect detection), LOG1~LOG3 (Logic output signals), WAC (capacitor life warning), WAF (cooling fan warning), FR (starting contact), OHF (heat sink overheat warning), LOC (Low load), MO1~MO3 (general outputs for EzSQ), IRDY (drive ready), FWR (forward operation), RVR (reverse operation), MJA (major failure), WCO (window comparator O), WCOI (window comparator Ol), FREF (frequency command source), REF (run command source), SETM (second motor in operation), EDM (STO (safe torque off) performance monitor), OP (option control signal), NO (no function) | |
| | Standard functions | Free-V/Hz, manual/automatic torque boost, output voltage gain adjustment, AVR function, reduced voltage start, motor data selection, auto-tuning, motor stabilization control, reverse running protection, simple position control, simple torque control, torque limiting, automatic carrier frequency reduction, energy saving operation, PID function, non-stop operation at instantaneous power failure, brake control, DC injection braking, dynamic braking (BRD), frequency upper and lower limiters, jump frequencies, curve accel and decel (S, U, inversed U,EL-S), 16-stage speed profile, fine adjustment of start frequency, accel and decel stop, process jogging, frequency calculation, frequency addition, 2-stage accel/decel, stop mode selection, start/end freq., analog input filter, window comparators, input terminal response time, output signal delay/hold function, rotation direction restriction, stop key selection, software lock, safe stop function, scaling function, display restriction, password function, user parameter, initialization, initial display selection, cooling fan control, warning, trip retry, frequency pull-in restart, frequency matching, overload restriction, over current restriction, DC bus voltage AVR | |
| | Analog inputs | 2 analog inputs 0 to 10 V (10 KΩ), 4 to 20mA (100 Ω) | |
| | Pulse train input terminal | 0 to 10 V (up to 24 V), up to 32 KHz | |
| | Accel/Decel times | 0.01 to 3600.0 s (line/curve selection), 2nd accel/decel setting available | |
| | Display | Status indicator LED's Run, Program, Power, Alarm, Hz, Amps | |
| | | Digital operator: Available to monitor 32 items: frequency reference, output current, output frequency... | |
| | Protection functions | Motor overload protection | Electronic Thermal overload relay and PTC thermistor input |
| | | Instantaneous overcurrent | 200% of rated current |
| Overload | | Dual rating: Heavy duty (CT): 150% for 1 minute Normal Duty (VT): 120% for 1 minute | |
| Overvoltage | | 800 V for 400 V type and 400 V for 200 V type | |
| Undervoltage | | 345 V for 400 V type and 172.5 V for 200 V type | |
| Momentary power loss | | Following items are selectable: Alarm, decelerates to stop, decelerates to stop with DC bus controlled, restart | |
| Cooling fin overheat | | Temperature monitor and error detection | |
| Stall prevention level | | Stall prevention during acceleration/deceleration and constant speed | |
| Ambient conditions | Ground fault | Detection at power-on | |
| | Power charge indication | On when power is supplied to the control part | |
| | Degree of protection | IP20, Varnish coating on PCB | |
| | Ambient humidity | 90% RH or less (without condensation) | |
| | Storage temperature | -20 °C to +65 °C (short-term temperature during transportation) | |
| | Ambient temperature | -10°C to 40°C | |
| | Installation | Indoor (no corrosive gas, dust, etc.) | |
| Installation height | Max. 1000 m | | |
| Vibration | 5.9 m/s ² (0.6G), 10 to 55 Hz | | |

3G3MX2 AC Drives



| Voltage class | Drive model | Figure | Dimensions (Unit: mm) | | | | | | | | | Weight (kg) |
|-----------------------|--------------|--------|-----------------------|-----|-----|-----|-----|-------|------|-----|-----|-------------|
| | | | W | W1 | H | H1 | t | D | D1 | D2 | d | |
| Single-phase 200 V | 3G3MX2-AB001 | 1 | 68 | 56 | 128 | 118 | - | 109 | 13.5 | - | - | 1.0 |
| | 3G3MX2-AB002 | 1 | | | | | | 123 | 27 | - | - | 1.0 |
| | 3G3MX2-AB004 | 1 | | | | | | 170.5 | 55 | 4.4 | 4.5 | 1.1 |
| | 3G3MX2-AB007 | 2 | 108 | 96 | 128 | 118 | - | 170.5 | 55 | 4.4 | 4.5 | 1.4 |
| | 3G3MX2-AB015 | 2 | | | | | | | | | | 1.8 |
| | 3G3MX2-AB022 | 2 | | | | | | | | | | 1.8 |
| Three-phase 200 V | 3G3MX2-A2001 | 1 | 68 | 56 | 128 | 118 | - | 109 | 13.5 | - | - | 1.0 |
| | 3G3MX2-A2002 | 1 | | | | | | 1134 | 27 | - | - | 1.0 |
| | 3G3MX2-A2004 | 1 | | | | | | 146 | 50 | - | - | 1.1 |
| | 3G3MX2-A2007 | 1 | 108 | 96 | 128 | 118 | - | 170.5 | 55 | 4.4 | 4.5 | 1.2 |
| | 3G3MX2-A2015 | 2 | | | | | | | | | | 1.6 |
| | 3G3MX2-A2022 | 2 | | | | | | | | | | 1.8 |
| | 3G3MX2-A2037 | 3 | 140 | 128 | 128 | 118 | 5 | 170.5 | 55 | 4.4 | 4.5 | 2.0 |
| | 3G3MX2-A2055 | 3 | 140 | 122 | 260 | 248 | 6 | 155 | 73.3 | 6 | 6 | 3.0 |
| | 3G3MX2-A2075 | 3 | | | | | | | | | | 3.4 |
| | 3G3MX2-A2110 | 3 | | | | | | | | | | 180 |
| 3G3MX2-A2150 | 3 | 220 | 192 | 350 | 336 | 7 | 175 | 84 | 5 | 7 | 7.4 | |
| Three-phase 400 V | 3G3MX2-A4004 | 2 | 108 | 96 | 128 | 118 | - | 144 | 28 | - | - | 1.5 |
| | 3G3MX2-A4007 | 2 | | | | | | 171 | 55 | - | - | 1.6 |
| | 3G3MX2-A4015 | 2 | | | | | | 171 | 55 | - | - | 1.8 |
| | 3G3MX2-A4022 | 2 | 140 | 122 | 260 | 248 | 6 | 155 | 73.3 | 6 | 6 | 1.9 |
| | 3G3MX2-A4030 | 2 | | | | | | | | | | 1.9 |
| | 3G3MX2-A4040 | 3 | | | | | | | | | | 128 |
| | 3G3MX2-A4055 | 3 | 180 | 160 | 296 | 284 | 7 | 175 | 97 | 5 | 7 | 3.5 |
| | 3G3MX2-A4075 | 3 | | | | | | | | | | 3.5 |
| | 3G3MX2-A4110 | 3 | | | | | | | | | | 4.7 |
| | 3G3MX2-A4150 | 3 | 180 | 160 | 296 | 284 | 7 | 175 | 97 | 5 | 7 | 5.2 |

RFI Filters, Footprint Type

| Voltage | Drive Model 3G3MX2-□ | RFI Filter Model | RFI Filter Rated Current (A) | Dimensions (Unit: mm) | | | | | | |
|--------------------|-------------------------|------------------|------------------------------|-----------------------|----|-----|-----|-----|----|--|
| | | | | W | H | L | X | Y | M | |
| 1-phase 200 VAC | AB001/AB002/AB004 | 3G3AX-FIM1010-RE | 10 | 71 | 45 | 169 | 156 | 51 | M4 | |
| | AB007 | 3G3AX-FIM1014-RE | 14 | 111 | 50 | 169 | 156 | 91 | M4 | |
| | AB015/AB022 | 3G3AX-FIM1024-RE | 24 | 111 | 50 | 169 | 156 | 91 | M4 | |
| 3-phase 200 VAC | A2001/A2002/A2004/A2007 | 3G3AX-FIM2010-RE | 10 | 82 | 50 | 194 | 181 | 62 | M4 | |
| | A2015/A2022 | 3G3AX-FIM2020-RE | 20 | 111 | 50 | 169 | 156 | 91 | M4 | |
| | A2037 | 3G3AX-FIM2030-RE | 30 | 144 | 50 | 174 | 161 | 120 | M4 | |
| | A2055/A2075 | 3G3AX-FIM2060-RE | 60 | 150 | 52 | 320 | 290 | 122 | M5 | |
| | A2110 | 3G3AX-FIM2080-RE | 80 | 188 | 62 | 362 | 330 | 160 | M5 | |
| | A2150 | 3G3AX-FIM2100-RE | 100 | 220 | 62 | 415 | 380 | 192 | M6 | |
| 3-phase 400 VAC | A4004/A4007 | 3G3AX-FIM3005-RE | 5 | 111 | 45 | 169 | 156 | 91 | M4 | |
| | A4015/A4022/A4030 | 3G3AX-FIM3010-RE | 10 | 111 | 45 | 169 | 156 | 91 | M4 | |
| | A4040 | 3G3AX-FIM3014-RE | 14 | 144 | 50 | 174 | 161 | 120 | M4 | |
| | A4055/A4075 | 3G3AX-FIM3030-RE | 23 | 150 | 52 | 306 | 290 | 122 | M5 | |
| | A4110/A4150 | 3G3AX-FIM3050-RE | 50 | 182 | 62 | 357 | 330 | 160 | M5 | |



Accessories

Input AC Reactor

| Voltage class | Model 3G3AX-□ | Dimensions (Unit: mm) | | | | | | Weight (kg) |
|---------------|----------------|-----------------------|----|-----|-----|----|-----|-------------|
| | | A | B2 | C2 | D | E | F | |
| 200 V | RAI02800080-DE | 120 | 70 | 120 | 80 | 52 | 5.5 | 1.78 |
| | RAI00880200-DE | 120 | 80 | 120 | 80 | 62 | 5.5 | 2.35 |
| | RAI00350335-DE | 180 | 85 | 190 | 140 | 55 | 6 | 5.5 |
| | RAI00180670-DE | 180 | 85 | 190 | 140 | 55 | 6 | 5.5 |
| 400 V | RAI07700050-DE | 120 | 70 | 120 | 80 | 52 | 5.5 | 1.78 |
| | RAI03500100-DE | 120 | 80 | 120 | 80 | 62 | 5.5 | 2.35 |
| | RAI01300170-DE | 120 | 80 | 120 | 80 | 62 | 5.5 | 2.50 |
| | RAI00740335-DE | 180 | 85 | 190 | 140 | 55 | 6 | 5.5 |

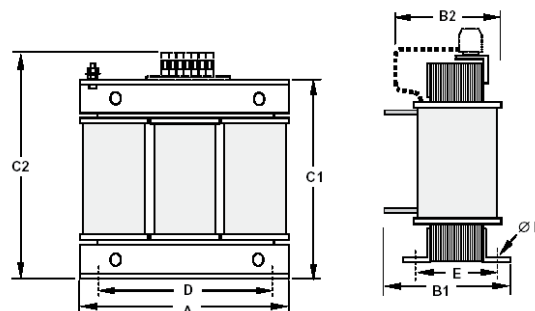

DC Reactor

| Voltage class | Model 3G3AX-□ | Dimensions (Unit: mm) | | | | | | | | Weight (kg) |
|---------------|---------------|-----------------------|-----|-----|-----|-----|------|-----|---|-------------|
| | | A | B | C | D | E | F | G | H | |
| 200 V | RC21400016-DE | 84 | 113 | 96 | 101 | 66 | 5 | 7.5 | 2 | 1.22 |
| | RC10700032-DE | | | 105 | | | | | | 1.60 |
| | RC06750061-DE | | | 116 | | | | | | 1.95 |
| | RC03510093-DE | | | 124 | | | | | | 120 |
| | RC02510138-DE | 136 | 135 | 94 | 7 | 9.5 | 5.20 | | | |
| | RC01600223-DE | 146 | 135 | 94 | | | 6.00 | | | |
| | RC01110309-DE | 160 | 160 | 115 | 2 | 2 | 11.4 | | | |
| | RC00840437-DE | 177 | 160 | 115 | | | 14.3 | | | |
| | RC00590614-DE | 182.6 | 160 | 115 | 7 | 2 | 14.3 | | | |
| | RC00440859-DE | 182.6 | 160 | 115 | 7 | 2 | 14.3 | | | |
| 400 V | RC43000020-DE | 84 | 113 | 96 | 101 | 66 | 5 | 7.5 | 2 | 1.22 |
| | RC27000030-DE | | | 105 | | | | | | 1.60 |
| | RC14000047-DE | | | 116 | | | | | | 1.95 |
| | RC10100069-DE | | | 124 | | | | | | 120 |
| | RC06400116-DE | 136 | 135 | 94 | 7 | 9.5 | 5.20 | | | |
| | RC04410167-DE | 146 | 135 | 94 | | | 6.00 | | | |
| | RC03350219-DE | 160 | 160 | 115 | 2 | 2 | 11.4 | | | |
| | RC02330307-DE | 177 | 160 | 115 | | | 14.3 | | | |
| | RC01750430-DE | 182.6 | 160 | 115 | 7 | 2 | 14.3 | | | |

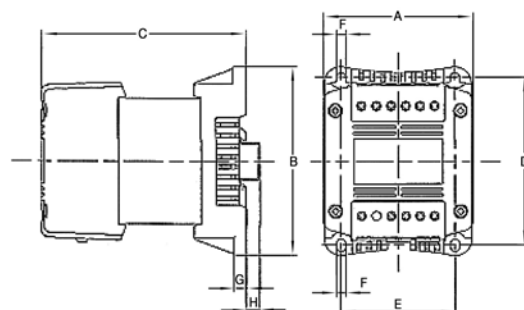

Output AC Reactor

| Voltage class | Model 3G3AX-□ | Dimensions (Unit: mm) | | | | | | Weight (kg) |
|----------------|----------------|-----------------------|-----|-----|-----|----|------|-------------|
| | | A | B2 | C2 | D | E | F | |
| 200 V | RAO11500026-DE | 120 | 70 | 120 | 80 | 52 | 5.5 | 1.78 |
| | RAO07600042-DE | 120 | 70 | 120 | 80 | 52 | 5.5 | 1.78 |
| | RAO04100075-DE | 120 | 80 | 120 | 80 | 62 | 5.5 | 2.35 |
| | RAO03000105-DE | 120 | 80 | 120 | 80 | 62 | 5.5 | 2.35 |
| | RAO01830180-DE | 180 | 85 | 190 | 140 | 55 | 6 | 5.5 |
| | RAO01150220-DE | 180 | 85 | 190 | 140 | 55 | 6 | 5.5 |
| | RAO00950320-DE | 180 | 85 | 205 | 140 | 55 | 6 | 6.5 |
| | RAO00630430-DE | 180 | 95 | 205 | 140 | 65 | 6 | 9.1 |
| RAO00490640-DE | 180 | 95 | 205 | 140 | 65 | 6 | 9.1 | |
| 400 V | RAO16300038-DE | 120 | 70 | 120 | 80 | 52 | 5.5 | 1.78 |
| | RAO11800053-DE | 120 | 80 | 120 | 80 | 52 | 5.5 | 2.35 |
| | RAO07300080-DE | 120 | 80 | 120 | 80 | 62 | 5.5 | 2.35 |
| | RAO04600110-DE | 180 | 85 | 190 | 140 | 55 | 6 | 5.5 |
| | RAO03600160-DE | 180 | 85 | 205 | 140 | 55 | 6 | 6.5 |
| | RAO02500220-DE | 180 | 95 | 205 | 140 | 55 | 6 | 9.1 |
| RAO02000320-DE | 180 | 105 | 205 | 140 | 85 | 6 | 11.7 | |

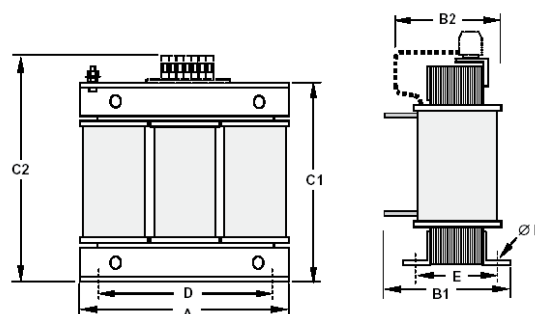

Reactors

Input AC Reactor

| 3-phase 200 VAC | | | | 3-phase 400 VAC | | | |
|------------------------------|----------------|---------------|------------|------------------------------|----------------|---------------|------------|
| Max. applicable motor output | Model 3G3AX-□ | Current value | Inductance | Max. applicable motor output | Model 3G3AX-□ | Current value | Inductance |
| 1.5 kW (2 HP) | RAI02800080-DE | 8.0 A | 2.8 mH | 1.5 kW (2 HP) | RAI07700050-DE | 5.0 A | 7.7 mH |
| 3.7 kW (5 HP) | RAI00880200-DE | 20.0 A | 0.88 mH | 4.0 kW (5 1/2 HP) | RAI03500100-DE | 10.0 A | 3.5 mH |
| 7.5 kW (10 HP) | RAI00350335-DE | 33.5 A | 0.35 mH | 7.5 kW (10 HP) | RAI01300170-DE | 17.0 A | 1.3 mH |
| 15 kW (20 HP) | RAI00180670-DE | 67.0 A | 0.18 mH | 15 kW (20 HP) | RAI00740335-DE | 33.5 A | 0.74 mH |



DC Reactor

| 1-phase 200 VAC | | 3-phase 200 VAC | | | | | 3-phase 400 VAC | | | | |
|-----------------|---------------|------------------------------|----------------|---------------|---------------|------------|------------------------------|----------------|---------------|---------------|------------|
| Drive 3G3MX2-□ | Model 3G3AX-□ | Max. applicable motor output | Drive 3G3MX2-□ | Model 3G3AX-□ | Current value | Inductance | Max. applicable motor output | Drive 3G3MX2-□ | Model 3G3AX-□ | Current value | Inductance |
| AB001 | RC10700032-RE | 0.2 kW (1/4 HP) | A2001 | RC21400016-DE | 1.6 A | 21.4 mH | 0.4 kW (1/2 HP) | A4004 | RC43000020-DE | 2.0 A | 43.0 mH |
| AB002 | | 0.4 kW (1/2 HP) | A2002 | | | | 0.7 kW (1 HP) | A4007 | RC27000030-DE | 3.0 A | 27.0 mH |
| AB004 | RC06750061-RE | 0.7 kW (1 HP) | A2004 | RC10700032-DE | 3.2 A | 10.7 mH | 1.5 kW (2 HP) | A4015 | RC14000047-DE | 4.7 A | 14.0 mH |
| AB007 | RC03510093-RE | 1.5 kW (2 HP) | A2007 | RC06750061-DE | 6.1 A | 6.75 mH | 2.2 kW (3 HP) | A4022 | RC10100069-DE | 6.9 A | 10.1 mH |
| AB015 | RC02510138-RE | 2.2 kW (3 HP) | A2015 | RC03510093-DE | 9.3 A | 3.51 mH | 3.0 kW (4 HP) | A4030 | RC08250093-DE | 9.3 A | 8.25 mH |
| AB022 | RC01600223-RE | 3.7 kW (5 HP) | A2022 | RC02510138-DE | 13.8 A | 2.51 mH | 4.0 kW (5 1/2 HP) | A4040 | RC06400116-DE | 11.6 A | 6.40 mH |
| - | | 5.5 kW (7 1/2 HP) | A2037 | RC01600223-DE | 22.3 A | 1.60 mH | 5.5 kW (7 1/2 HP) | A4055 | RC04410167-DE | 16.7 A | 4.41 mH |
| | | 7.5 kW (10 HP) | A2055 | RC01110309-DE | 30.9 A | 1.11 mH | 7.5 kW (10 HP) | A4075 | RC03350219-DE | 21.9 A | 3.35 mH |
| | | 11.0 kW (15 HP) | A2075 | RC00840437-DE | 43.7 A | 0.84 mH | 11.0 kW (15 HP) | A4011 | RC02330307-DE | 30.7 A | 2.33 mH |
| | | 15.0 kW (20 HP) | A2011 | RC00590614-DE | 61.4 A | 0.59 mH | 15.0 kW (20 HP) | A4015 | RC01750430-DE | 43.0 A | 1.75 mH |
| | | | A2015 | RC00440859-DE | 85.9 A | 0.44 mH | | | | | |

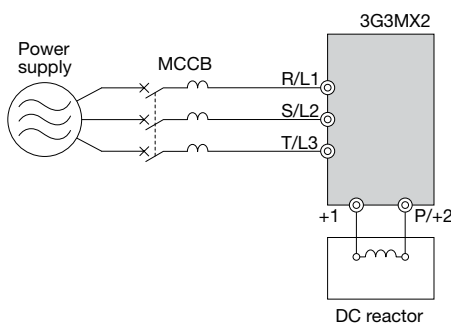

Output AC Reactor

| 3-phase 200 VAC | | | | | 3-phase 400 VAC | | | | | | | | |
|------------------------------|--|----------------|---------------|------------|------------------------------|-------------------|----------------|---------------|------------|-------------|----------------|-------|---------|
| Max. applicable motor output | Model 3G3MX2-□ | Model 3G3AX-□ | Current value | Inductance | Max. applicable motor output | Model 3G3MX2-□ | Model 3G3AX-□ | Current value | Inductance | | | | |
| 0.4 kW (1/2 HP) | A2001/A2002/A2004 AB001/AB002/AB004 | RAO11500026-DE | 2.6 A | 11.50 mH | 1.5 kW (2 HP) | A4004/A4007/A4015 | RAO16300038-DE | 3.8 A | 16.30 mH | | | | |
| 0.75 kW (1 HP) | | | | | | | | | | A2007/AB007 | RAO07600042-DE | 4.2 A | 7.60 mH |
| 1.5 kW (2 HP) | | | | | | | | | | A2015/AB015 | RAO04100075-DE | 7.5 A | 4.10 mH |
| 2.2 kW (3 HP) | A2022/AB022 | RAO03000105-DE | 10.5 A | 3.00 mH | 2.2 kW (3 HP) | A4022 | RAO11800053-DE | 5.3 A | 11.80 mH | | | | |
| 3.7 kW (5 HP) | A2037 | RAO01830160-DE | 16.0 A | 1.83 mH | 4.0 kW (5 1/2 HP) | A4030/A4040 | RAO07300080-DE | 8.0 A | 7.30 mH | | | | |
| 5.5 kW (7 1/2 HP) | A2055 | RAO01150220-DE | 22.0 A | 1.15 mH | 5.5 kW (7 1/2 HP) | A4055 | RAO04600110-DE | 11.0 A | 4.60 mH | | | | |
| 7.5 kW (10 HP) | A2075 | RAO00950320-DE | 32.0 A | 0.95 mH | 7.5 kW (10 HP) | A4075 | RAO03600160-DE | 16.0 A | 3.60 mH | | | | |
| 11.0 kW (15 HP) | - | RAO00630430-DE | 43.0 A | 0.63 mH | 11.0 kW (15 HP) | - | RAO02500220-DE | 22.0 A | 2.50 mH | | | | |
| 15.0 kW (20 HP) | - | RAO00490640-DE | 64.0 A | 0.49 mH | 15.0 kW (20 HP) | - | RAO02000320-DE | 32.0 A | 2.00 mH | | | | |

Accessories

Chokes

| Model 3G3AX-□ | Diameter | Motor | Description | Dimensions (Unit: mm) | | | | | | | Weight (kg) |
|---------------|----------|-------|-------------------------------------|-----------------------|-----|----|-----|-----|----|---|-------------|
| | d | kW | | HP | L | W | H | X | Y | m | |
| FEJ2102-RE | 21 | < 2.2 | For 2.2 kW (3.0 HP) motors or below | < 3.0 | 85 | 22 | 46 | 70 | - | 5 | 0.1 |
| FEJ2515-RE | 25 | < 15 | For 15 kW (20 HP) motors or below | < 20 | 105 | 25 | 62 | 90 | - | 5 | 0.2 |
| FEJ5045-RE | 50 | < 45 | For 45 kW (60 HP) motors or below | < 60 | 150 | 50 | 110 | 125 | 30 | 5 | 0.7 |

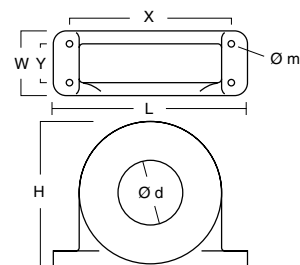

Resistor

| Model | Figure | Dimensions (Unit: mm) | | | | | Weight (kg) |
|---------------------|--------|-----------------------|-----|-----|-----|------|-------------|
| | | L | H | M | I | T | |
| 3G3AX-REM00K1400-IE | 1 | 105 | 27 | 36 | 94 | - | 0.2 |
| 3G3AX-REM00K2070-IE | | | | | | | |
| 3G3AX-REM00K2120-IE | | | | | | | |
| 3G3AX-REM00K2200-IE | | | | | | | |
| 3G3AX-REM00K4075-IE | | 200 | 27 | 36 | 189 | - | 0.425 |
| 3G3AX-REM00K4035-IE | | | | | | | |
| 3G3AX-REM00K4030-IE | | | | | | | |
| 3G3AX-REM00K5120-IE | | | | | | | |
| 3G3AX-REM00K6100-IE | 320 | 27 | 36 | 309 | - | 0.73 | |
| 3G3AX-REM00K6035-IE | | | | | | | |
| 3G3AX-REM00K9070-IE | 2 | 200 | 62 | 100 | 74 | - | 1.41 |
| 3G3AX-REM00K9020-IE | | | | | | | |
| 3G3AX-REM00K9017-IE | | | | | | | |
| 3G3AX-REM01K9070-IE | 3 | 365 | 73 | 105 | 350 | 70 | 4 |
| 3G3AX-REM01K9017-IE | | | | | | | |
| 3G3AX-REM02K1070-IE | 4 | 310 | 100 | 240 | 295 | 210 | 7 |
| 3G3AX-REM02K1017-IE | | | | | | | |
| 3G3AX-REM03K5035-IE | | 365 | 100 | 240 | 350 | 210 | 8 |
| 3G3AX-REM03K5010-IE | | | | | | | |

3G3AX-REM00K1200



FIGURE 2

FIGURE 1



FIGURE 3



FIGURE 4



Standard Connections

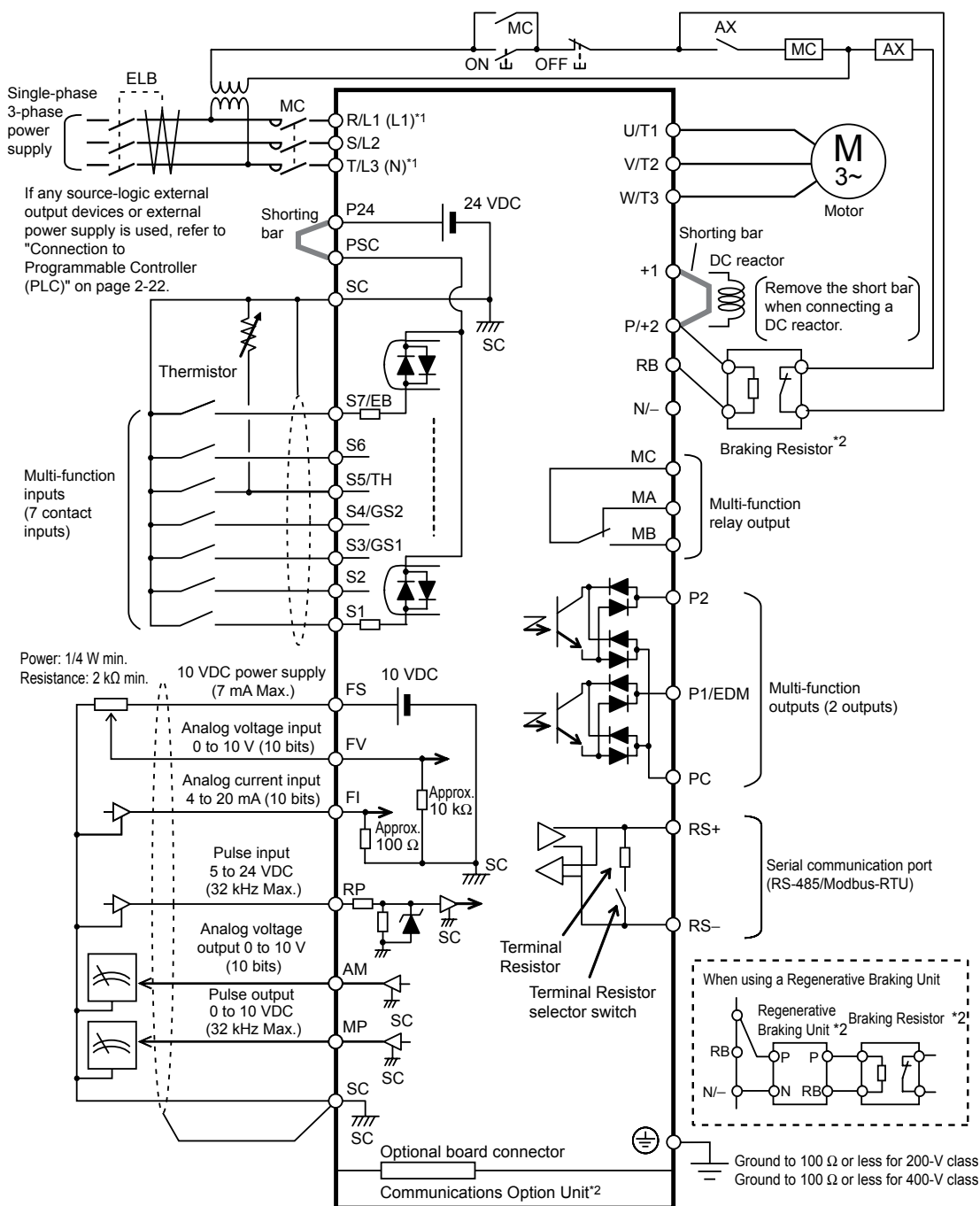

*1 Connect to terminals L1 and N on a single-phase, 200-V AC Drive (3G3MX2-AB□□□).
*2 Optional.

Main Circuit Terminals

| Terminal symbol | Terminal name | Description |
|-------------------------|---|--|
| R/L1, L1, S/L2, T/L3, N | Main power supply input terminal | Connect the input AC power supply. Connect to terminals L1 and N on a single-phase, 200-V AC Drive (3G3MX2-AB□□□). |
| U/T1, V/T2, W/T3 | Drive output terminal | Connect a 3-phase motor. |
| +1, P/+2 | DC reactor connection terminal | Remove the shorting bar between terminals +1 and P/+2, and connect the optional DC reactor. |
| P/+2, RB | Braking Resistor connection terminal | Connect optional braking resistors. (If a braking torque is required) |
| P/+2, N/- | Regenerative braking unit connection terminal | Connect optional regenerative braking units. (When braking torque is required or the built-in braking circuit is not sufficient) |
| G | Ground terminal | This is a ground terminal. Connect this terminal to the ground. Provide Class D grounding for 200 V class models, and class C grounding for 400 V class models. On 200 V class models of 3.7 kW or below and 400 V class models of 4.0 kW or below, the ground terminal is located on the cooling fin. |

Control Circuit Terminals

| Terminal symbol | | Terminal name | Description | Specifications | |
|----------------------|-------------------------|--|---|--|---|
| Analog | Power supply | SC | Input signal common | This is a common terminal used by the internal power supply, digital input and analog input/output terminals. | |
| | | FS | Frequency reference power supply | 10 VDC power supply for the FV terminal. Allowable max. current: 7 mA | |
| | Frequency setting input | FV | Frequency reference input terminal (analog voltage input) | Use this terminal if the frequency reference is provided by 0 to 10 VDC voltage input. Input impedance Approx. 10 kΩ Allowable input voltage range -0.3 to +12 VDC | |
| | | FI | Frequency reference terminal (analog current input) | Use this terminal if the frequency reference is provided by 4 to 20 mA current input. Input impedance 100 Ω Allowable input range 0 to 24 mA | |
| | Sensor input | S5/TH | External thermistor input (also used as multi-function input terminal) | Connect an external thermistor between the SCs, to trip the Drive when a temperature error occurs. (The drive will trip when the input from thermistor is approx. 3 kΩ or higher.) Since this input is also used as the multifunction input terminal, setting of C005 is required. PTC type | |
| Output | AM | Multi-function analog output (voltage) | Specified signals can be output using voltage signals of 0 to 10 VDC. AM | | |
| Digital | Power supply | SC | Input signal common | This is a common terminal used by the internal power supply, digital input and analog input/output terminals. | |
| | | P24 | Power supply terminal for input signal | 24 VDC power supply for contact input signal. This is used as a common terminal if the source logic is input. Allowable max. current: 100 mA | |
| | | PSC | Power supply terminal for input terminal | Sink logic input: Shorted with P24 Source logic input: Shorted with SC To drive the contact input using an external power supply, remove the shorting bar. | |
| | Input | Contact | S7/EB S6 S5/TH S4/GS2 S3/GS1 S2 S1 | Multi-function input terminal | Select 7 functions from among 59, and allocate them to terminals S1 through S7/EB. Both sink and source logics are supported. Voltage between each input and PSC ON voltage: 18 V min. OFF voltage: 3 V max. Allowable max. voltage: 27 VDC Load current: 5 mA (at 24 V) |
| | | | S4/GS2 S3/GS1 | Safety input | Enabled when the safety function selector switch is turned ON. |
| | Input | Pulse | RP | Pulse input-A | A pulse input for frequency setting. (Take note that the internal circuit is different from input terminals S7/EB.) Input pulse 32 kHz max. Voltage between input and SC ON voltage: 4 V min. OFF voltage: 1 V max. Allowable max. voltage: 27 VDC |
| | | | S7/EB | Pulse input-B | A pulse input for frequency setting. (Take note that the internal circuit is different from input terminal RP.) Input pulse 1.8 kHz max. ON voltage: 18 V min. OFF voltage: 3 V max. Allowable max. voltage: 27 VDC Load current: 5 mA (at 24 V) |
| | Output | Open collector | P1/EDM P2 | Multi-function output terminal | Select 2 functions from among 43, and allocate them to terminals P1 through P2. Both sink and source logics are supported. Open collector output Between each terminal and PC Allowable max. voltage: 27 V Allowable max. current: 50 mA Voltage drop when ON: 4 V max. |
| | | | P1/EDM | Safety monitor | Enabled when the EDM function selector switch is ON. |
| | | Relay | MA MB | Relay output terminal | Select the desired functions from among 43 functions, and allocate them to these terminals. SPDT contact. The factory default of Relay Output (MA, MB) Contact Selection (C036) is NC contact between MA-MC, and NO contact between MB-MC. |
| MC | | | Relay output common | | |
| Pulse | MP | Pulse output | Pulses are output. Output pulse: 32 kHz max. Output voltage: 10 VDC Allowable max. current: 2 mA | | |
| Serial communication | RS+ RS- | Modbus port (RS-485) | RS-485 port RS+ RS-485 differential (+) signal RS- RS-485 differential (-) signal | Max. speed: 115.2 kbps Built-in Terminal Resistor: 200 Ω Slide switch selection | |

Side by side mounting

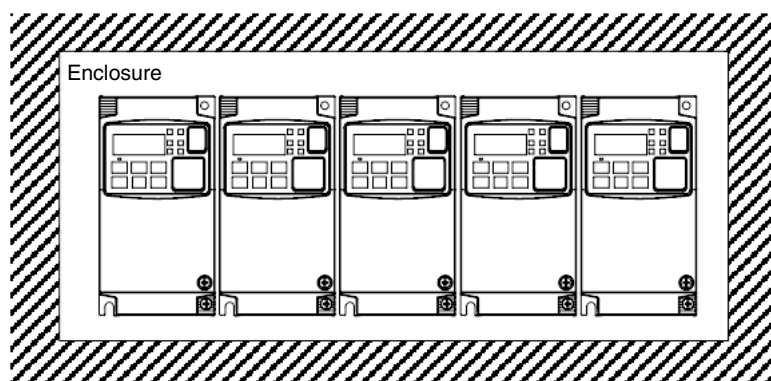

Heat Loss

Single-phase 200 V class

| Model 3G3MX2-□ | | AB001 | AB002 | AB004 | AB007 | AB015 | AB022 |
|--------------------------|---------|--------------|-------|-------|-------|--------------------|-------|
| Drive capacity kVA | 200V VT | 0.4 | 0.6 | 1.2 | 2.0 | 3.3 | 4.1 |
| | 200V CT | 0.2 | 0.5 | 1.0 | 1.7 | 2.7 | 3.8 |
| | 240V VT | 0.4 | 0.7 | 1.4 | 2.4 | 3.9 | 4.9 |
| | 240V CT | 0.3 | 0.6 | 1.2 | 2.0 | 3.3 | 4.5 |
| Rated current (A) VT | | 1.2 | 1.9 | 3.4 | 6.0 | 9.6 | 12.0 |
| Rated current (A) CT | | 1.0 | 1.6 | 3.0 | 5.0 | 8.0 | 11.0 |
| Total heat loss | | 12 | 22 | 30 | 48 | 79 | 104 |
| Efficiency at rated load | | 89.5 | 90 | 93 | 94 | 95 | 95.5 |
| Cooling method | | Self cooling | | | | Forced-air-cooling | |

Three-phase 200 V class

| Model 3G3MX2-□ | | A2001 | A2002 | A2004 | A2007 | A2015 | A2022 | A2037 | A2055 | A2075 | A2110 | A2150 |
|--------------------------|--------|--------------|-------|-------|-------|-------|--------------------|-------|-------|-------|-------|-------|
| Drive capacity kVA | 200 VT | 0.4 | 0.6 | 1.2 | 2.0 | 3.3 | 4.1 | 6.7 | 10.3 | 13.8 | 19.3 | 23.9 |
| | 200 CT | 0.2 | 0.5 | 1.0 | 1.7 | 2.7 | 3.8 | 6.0 | 8.6 | 11.4 | 16.2 | 20.7 |
| | 240 VT | 0.4 | 0.7 | 1.4 | 2.4 | 3.9 | 4.9 | 8.1 | 12.4 | 16.6 | 23.2 | 28.6 |
| | 240 CT | 0.3 | 0.6 | 1.2 | 2.0 | 3.3 | 4.5 | 7.2 | 10.3 | 13.7 | 19.5 | 24.9 |
| Rated current (A) VT | | 1.2 | 1.9 | 3.4 | 6.0 | 9.6 | 12.0 | 19.6 | 30.0 | 40.0 | 56.0 | 69.0 |
| Rated current (A) CT | | 1.0 | 1.6 | 3.0 | 5.0 | 8.0 | 11.0 | 17.5 | 25.0 | 33.0 | 47.0 | 60.0 |
| Total heat loss | | 12 | 22 | 30 | 48 | 79 | 104 | 154 | 229 | 313 | 458 | 625 |
| Efficiency at rated load | | 89.5 | 90 | 93 | 94 | 95 | 95.5 | 96 | 96 | 96 | 96 | 96 |
| Cooling method | | Self cooling | | | | | Forced-air-cooling | | | | | |

Three-phase 400 V class

| Model 3G3MX2-□ | | A4004 | A4007 | A4015 | A4022 | A4030 | A4040 | A4055 | A4075 | A4110 | A4150 |
|--------------------------|---------|--------------|-------|-------|-------|--------------------|-------|-------|-------|-------|-------|
| Drive capacity kVA | 380V VT | 1.3 | 2.6 | 3.5 | 4.5 | 5.7 | 7.3 | 11.5 | 15.1 | 20.4 | 25.0 |
| | 380V CT | 1.1 | 2.2 | 3.1 | 3.6 | 4.7 | 6.0 | 9.7 | 11.8 | 15.7 | 20.4 |
| | 480V VT | 1.7 | 3.4 | 4.4 | 5.7 | 7.3 | 9.2 | 14.5 | 19.1 | 25.7 | 31.5 |
| | 480V CT | 1.4 | 2.8 | 3.9 | 4.5 | 5.9 | 7.6 | 12.3 | 14.9 | 19.9 | 25.7 |
| Rated current (A) VT | | 2.1 | 4.1 | 5.4 | 6.9 | 8.8 | 11.1 | 17.5 | 23.0 | 31.0 | 38.0 |
| Rated current (A) CT | | 1.8 | 3.4 | 4.8 | 5.5 | 7.2 | 9.2 | 14.8 | 18.0 | 24.0 | 31.0 |
| Total heat loss | | 35 | 56 | 96 | 116 | 125 | 167 | 229 | 296 | 411 | 528 |
| Efficiency at rated load | | 92 | 93 | 94 | 95 | 96 | 96 | 96 | 96.2 | 96.4 | 96.6 |
| Cooling method | | Self cooling | | | | Forced-air-cooling | | | | | |

Ordering Information

3G3MX2 AC Drives

| Specifications | | | | | | | Model |
|-----------------|------------------------------|--------------|-----------------|------------------------------|--------------|-----------------|--------------|
| Voltage class | Constant torque (Heavy load) | | | Variable torque (Light load) | | | Standard |
| | Max motor kW | Max motor HP | Rated current A | Max motor kW | Max motor HP | Rated current A | |
| 1-phase 200 VAC | 0.1 | 1/8 | 1.0 | 0.2 | 1/4 | 1.2 | 3G3MX2-AB001 |
| | 0.2 | 1/4 | 1.6 | 0.4 | 1/2 | 1.9 | 3G3MX2-AB002 |
| | 0.4 | 1/2 | 3.0 | 0.55 | 3/4 | 3.5 | 3G3MX2-AB004 |
| | 0.75 | 1 | 5.0 | 1.1 | 1 1/2 | 6.0 | 3G3MX2-AB007 |
| | 1.5 | 2 | 8.0 | 2.2 | 3 | 9.6 | 3G3MX2-AB015 |
| | 2.2 | 3 | 11.0 | 3.0 | 4 | 12.0 | 3G3MX2-AB022 |
| 3-phase 200 VAC | 0.1 | 1/8 | 1.0 | 0.2 | 1/4 | 1.2 | 3G3MX2-A2001 |
| | 0.2 | 1/4 | 1.6 | 0.4 | 1/2 | 1.9 | 3G3MX2-A2002 |
| | 0.4 | 1/2 | 3.0 | 0.55 | 3/4 | 3.5 | 3G3MX2-A2004 |
| | 0.75 | 1 | 5.0 | 1.1 | 1 1/2 | 6.0 | 3G3MX2-A2007 |
| | 1.5 | 2 | 8.0 | 2.2 | 3 | 9.6 | 3G3MX2-A2015 |
| | 2.2 | 3 | 11.0 | 3.0 | 4 | 12.0 | 3G3MX2-A2022 |
| | 3.7 | 5 | 17.5 | 5.5 | 7 1/2 | 19.6 | 3G3MX2-A2037 |
| | 5.5 | 7 1/2 | 25.0 | 7.5 | 10 | 30.0 | 3G3MX2-A2055 |
| | 7.5 | 10 | 33.0 | 11 | 15 | 40.0 | 3G3MX2-A2075 |
| 3-phase 400 VAC | 0.4 | 1/2 | 1.8 | 0.75 | 1 | 2.1 | 3G3MX2-A4004 |
| | 0.75 | 1 | 3.4 | 1.5 | 2 | 4.1 | 3G3MX2-A4007 |
| | 1.5 | 2 | 4.8 | 2.2 | 3 | 5.4 | 3G3MX2-A4015 |
| | 2.2 | 3 | 5.5 | 3.0 | 4 | 6.9 | 3G3MX2-A4022 |
| | 3.0 | 4 | 7.2 | 4.0 | 5 | 8.8 | 3G3MX2-A4030 |
| | 4.0 | 5 | 9.2 | 5.5 | 7 1/2 | 11.1 | 3G3MX2-A4040 |
| | 5.5 | 7 1/2 | 14.8 | 7.5 | 10 | 17.5 | 3G3MX2-A4055 |
| | 7.5 | 10 | 18.0 | 11 | 15 | 23.0 | 3G3MX2-A4075 |
| | 11 | 15 | 24.0 | 15 | 20 | 31.0 | 3G3MX2-A4110 |
| | 15 | 20 | 31.0 | 18.5 | 25 | 38.0 | 3G3MX2-A4150 |

Accessories

| Types | Model | Description | Functions |
|------------------|-------------------|------------------------|--|
| Digital operator | 3G3AX-OP05 | LCD remote operator | 5 Line LCD remote operator with copy function, cable length max. 3m. |
| | 3G3AX-CAJOP300-EE | Remote operator cable | 3 meters cable for connecting remote operator |
| Accessories | 3G3AX-CUSBM002-E | PC configuration cable | Mini USB to USB connector cable |

Computer Software

| Item | Description | Functions |
|----------|-------------------------------------|--|
| CX-Drive | AC Drive/Servo Programming software | Set, transfer and compare parameters; perform test runs and adjustment; perform monitoring and data tracing for Omron drives and servos included in CX-One software. |
| CX-One | All-in-one Automation software | Program, configure and simulate operations for PLCs, HMIs, networks, motion control systems, temperature and process controllers. |

Note: Software runs on the following OS: Windows 2000 (Service Pack 3a or higher), XP, Vista or Windows 7.

ALL DIMENSIONS SHOWN ARE IN MILLIMETERS.
 To convert millimeters into inches, multiply by 0.03937. To convert grams into ounces, multiply by 0.03527.

Specifications are subject to change without notice.

Ordering Information

Communication Option Boards



| Types | Model | Description | Functions |
|-----------------------|-----------------|-----------------------------|---|
| Communication options | 3G3AX-MX2-PRT | Profibus option card | Used for running or stopping the drive, setting or referencing parameters, and monitoring output frequency, output current, or similar items through Profibus communications with the host controller. |
| | 3G3AX-MX2-DRT | DeviceNet option card | Used for running or stopping the drive, setting or referencing parameters, and monitoring output frequency, output current, or similar items through DeviceNet communications with the host controller. |
| | 3G3AX-MX2-ECT | EtherCAT option card | Used for running or stopping the drive, setting or referencing parameters, and monitoring output frequency, output current, or similar items through EtherCAT communications with the host controller. |
| | 3G3AX-MX2-CRT | CompoNet option card | Used for running or stopping the drive, setting or referencing parameters, and monitoring output frequency, output current, or similar items through CompoNet communications with the host controller. |
| | 3G3AX-MX2-ML2 | Mechatrolink II option card | Used for running or stopping the drive, setting or referencing parameters, and monitoring output frequency, output current, or similar items through Mechatrolink II communications with the host controller. |
| | 3G3AX-MX2-EIP-A | EtherNet/IP option card | Used for running or stopping the drive, setting or referencing parameters, and monitoring output frequency, output current, or similar items through EtherNet/IP communications with the host controller. |

Braking Unit, Braking Resistor Unit

| Voltage | Drive | | | | | Braking resistor unit | | | | | |
|--------------------------------|---------------------|-------|----------------|---------|-------------------------------|---------------------------------------|--------------|------------------|--|---------------|------------------|
| | Max. motor capacity | | Drive 3G3MX2-□ | | Connectable min. resistance Ω | Drive mounted type (3%ED, 10 sec max) | | Braking torque % | Drive mounted type (10%ED, 10 sec max) | | Braking torque % |
| | kW | HP | 3-phase | 1-phase | | Model 3G3AX-□ | Resistance Ω | | Model 3G3AX-□ | Resistance Ω | |
| 200 V (1-phase/ 3-phase) | 0.12 | 1/8 | A2001 | B001 | 100 | REM00K1400-IE | 400 | 200 | REM00K1400-IE | 400 | 200 |
| | 0.2 | 1/4 | A2002 | B002 | 100 | | | 180 | | | 180 |
| | 0.5 | 1/2 | A2004 | B004 | 100 | REM00K1200-IE | 200 | 180 | REM00K1200-IE | 200 | 180 |
| | 0.7 | 1 | A2007 | B007 | 50 | | | 100 | | | 200 |
| | 1.5 | 2 | A2015 | B015 | 50 | REM00K2070-IE | 70 | 140 | REM00K4075-IE | 75 | 130 |
| | 2.2 | 3 | A2022 | B022 | 35 | | | 90 | | | 180 |
| | 3.7 | 5 | A2037 | - | 35 | REM00K4075-IE | 75 | 50 | REM00K6035-IE | 35 | 100 |
| | 5.5 | 7.5 | A2055 | - | 20 | REM00K4035-IE | 35 | 75 | REM00K9017-IE | 17 | 150 |
| | 7.5 | 10 | A2075 | - | 17 | | | 55 | 110 | | |
| | 11 | 15 | A2110 | - | 17 | REM00K6035-IE | 35 | 40 | REM02K1017-IE | 17 | 75 |
| 15 | 20 | A2150 | - | 10 | REM00K9017-IE | 17 | 55 | REM03K5010-IE | 10 | 95 | |
| 400 V (3-phase) | 0.5 | 1/2 | A4004 | - | 180 | REM00K1400-IE | 400 | 200 | REM00K1400-IE | 400 | 200 |
| | 1 | 1 | A4007 | - | | | | 200 | | | 200 |
| | 1.5 | 2 | A4015 | - | 100 | REM00K1200-IE | 200 | 190 | REM00K2200-IE | 200 | 190 |
| | 2.2 | 3 | A4022 | - | | REM00K2200-IE | 200 | 130 | REM00K5120-IE | 120 | 200 |
| | 3 | 4 | A4030 | - | 70 | REM00K2120-IE | 120 | 160 | | | 160 |
| | 4 | 5 | A4040 | - | | REM00K4075-IE | 75 | 120 | 140 | REM00K6100-IE | 100 |
| | 5.5 | 7.5 | A4055 | - | REM00K4075-IE | | | 75 | 140 | REM00K9070-IE | 70 |
| | 7.5 | 10 | A4075 | - | | 100 | 110 | | | | |
| | 11 | 15 | A4110 | - | 35 | REM00K6100-IE | 100 | 50 | REM02K1070-IE | 70 | 75 |
| | 15 | 20 | A4150 | - | | REM00K9070-IE | 70 | 55 | REM03K5035-IE | 35 | 110 |

OMRON AUTOMATION AND SAFETY • THE AMERICAS HEADQUARTERS • Schaumburg, IL USA • 847.843.7900 • 800.556.6766 • www.omron247.com

OMRON CANADA, INC. • HEAD OFFICE

Toronto, ON, Canada • 416.286.6465 • 866.986.6766 • www.omron247.com

OMRON ELECTRONICS DE MEXICO • HEAD OFFICE

México DF • 52.55.59.01.43.00 • 001.800.556.6766 • mela@omron.com

OMRON ELECTRONICS DE MEXICO • SALES OFFICE

Apodaca, N.L. • 52.81.11.56.99.20 • 001.800.556.6766 • mela@omron.com

OMRON ELETRÔNICA DO BRASIL LTDA • HEAD OFFICE

São Paulo, SP, Brasil • 55.11.2101.6300 • www.omron.com.br

OMRON ARGENTINA • SALES OFFICE

Cono Sur • 54.11.4783.5300

OMRON CHILE • SALES OFFICE

Santiago • 56.9.9917.3920

OTHER OMRON LATIN AMERICA SALES

54.11.4783.5300

OMRON EUROPE B.V. • Wegalaan 67-69, NL-2132 JD, Hoofddorp, The Netherlands. • Tel: +31 (0) 23 568 13 00 • Fax: +31 (0) 23 568 13 88 • www.industrial.omron.eu

Authorized Distributor:

Automation Control Systems

- Machine Automation Controllers (MAC) • Programmable Controllers (PLC)
- Operator interfaces (HMI) • Distributed I/O • Software

Drives & Motion Controls

- Servo & AC Drives • Motion Controllers & Encoders

Temperature & Process Controllers

- Single and Multi-loop Controllers

Sensors & Vision

- Proximity Sensors • Photoelectric Sensors • Fiber-Optic Sensors
- Amplified Photomicrosensors • Measurement Sensors
- Ultrasonic Sensors • Vision Sensors • RFID/Code Readers

Industrial Components

- Relays • Pushbuttons & Indicators • Limit and Basic Switches • Timers
- Counters • Metering Devices • Power Supplies

Safety

- Laser Scanners • Safety Mats • Edges and Bumpers
- Programmable Safety Controllers • Light Curtains • Safety Relays
- Safety Interlock Switches



Компания «ЭлектроПласт» предлагает заключение долгосрочных отношений при поставках импортных электронных компонентов на взаимовыгодных условиях!

Наши преимущества:

- Оперативные поставки широкого спектра электронных компонентов отечественного и импортного производства напрямую от производителей и с крупнейших мировых складов;
- Поставка более 17-ти миллионов наименований электронных компонентов;
- Поставка сложных, дефицитных, либо снятых с производства позиций;
- Оперативные сроки поставки под заказ (от 5 рабочих дней);
- Экспресс доставка в любую точку России;
- Техническая поддержка проекта, помощь в подборе аналогов, поставка прототипов;
- Система менеджмента качества сертифицирована по Международному стандарту ISO 9001;
- Лицензия ФСБ на осуществление работ с использованием сведений, составляющих государственную тайну;
- Поставка специализированных компонентов (Xilinx, Altera, Analog Devices, Intersil, Interpoint, Microsemi, Aeroflex, Peregrine, Syfer, Eurofarad, Texas Instrument, Miteq, Cobham, E2V, MA-COM, Hittite, Mini-Circuits, General Dynamics и др.);

Помимо этого, одним из направлений компании «ЭлектроПласт» является направление «Источники питания». Мы предлагаем Вам помощь Конструкторского отдела:

- Подбор оптимального решения, техническое обоснование при выборе компонента;
- Подбор аналогов;
- Консультации по применению компонента;
- Поставка образцов и прототипов;
- Техническая поддержка проекта;
- Защита от снятия компонента с производства.



Как с нами связаться

Телефон: 8 (812) 309 58 32 (многоканальный)

Факс: 8 (812) 320-02-42

Электронная почта: org@eplast1.ru

Адрес: 198099, г. Санкт-Петербург, ул. Калинина, дом 2, корпус 4, литера А.