

DESCRIPTION

Demonstration circuit 933A is a HF/VHF/UHF Down-converting Mixer featuring the LT[®]5512. The RF input frequency is optimized for 140MHz, and the IF output frequency range is 0.1MHz to 100MHz. With minor component changes, the demo board can be configured for different RF frequencies from 250kHz to 450MHz.

The LT5512 is an active double-balanced mixer IC, optimized for high linearity HF, VHF and UHF applications. The IC includes an integrated LO buffer amplifier to drive the mixer and an RF buffer amplifier for improved LO-RF isolation. Internal bias circuits eliminate the need for precision external resistors and allow the device to be powered-down using the enable control (EN) pin.

The externally matched RF and IF ports allow the mixer to be used at very low frequencies, below 1MHz or up to 3GHz. The differential LO input is designed for single-ended or a differential drive.

The LT5512 is a high-linearity alternative to passive diode mixers. Unlike passive mixers, which have conversion loss and require high LO drive levels, the LT5512 delivers conversion gain and requires significantly lower LO drive levels.

Design files for this circuit board are available. Call the LTC factory.

Table 1. Typical Performance Summary ($V_{CC} = 5V$, EN = High, $f_{RF} = 140MHz$, $P_{RF} = -10dBm$, $f_{LO} = 150MHz$, $P_{LO} = -5dBm$, $f_{IF} = 10MHz$, $T_A = 25^{\circ}C$, unless otherwise noted. Test circuit shown in Figure 2.)

PARAMETER	CONDITION	VALUE
Supply Voltage		4.5V to 5.25V
Supply Current	EN = High	56mA
Maximum Shutdown Current	EN = Low	100 μ A
Conversion Gain		2dB
Input 3rd Order Intercept	2-Tone, -10dBm/tone, $\Delta f = 200kHz$	20.7dBm
Single-Sideband Noise Figure		10.3dB
LO to RF Leakage		$\leq -63dBm$
LO to IF Leakage		$\leq -35dBm$
RF to LO isolation		$> 61dB$
Input 1dB Compression		10.5dBm

APPLICATION NOTE

ABSOLUTE MAXIMUM INPUT RATING

Supply Voltage	5.5V
Enable Voltage.....	-0.3V to $V_{cc}+0.3V$
LO+ to LO- Differential Voltage	$\pm 1.5V$
.....	(+6dBm equivalent)
RF+ to RF- Differential Voltage.....	$\pm 0.7V$
.....	(+11dBm equivalent)

FREQUENCY RANGE

Demonstration circuit 933A is optimized for 140MHz RF to 10MHz IF downconversion with high-side LO injection. However, it can also be used at other frequencies.

The RF input port is well matched with better than 10dB return loss over the frequency range from 100MHz to 195MHz. The simple resistive LO input matching is robust up to 1.5GHz. The IF output port has better than 10dB return loss from 500kHz to 95MHz.

With proper matching, the RF, LO and IF ports can be tuned for operation at other frequencies. Please refer to the LT5512 datasheet Applications Information section.

QUICK START PROCEDURE

Demonstration circuit 933A is easy to set up to evaluate the performance of the LT5512. Refer to Figure 1 for proper measurement equipment setup and follow the procedure below:

1. Connect signal generator outputs to demo board RFin port (SMA connector J1) and LOin port (SMA connector J2) via coaxial cable.
2. Connect demo board IFout port (SMA connector J3) to spectrum analyzer input via coaxial cable.

TEST EQUIPMENT AND SETUP

Refer to Figure 1 for proper measurement equipment setup.

Use high performance signal generators with low harmonic output for 2-tone measurements. Otherwise, low-pass filters at the signal generator outputs should be used to suppress higher-order harmonics.

High quality combiners that provide broadband 50 Ω termination on all ports and have good port-to-port isolation should be used. Attenuators on the outputs of the signal generators are recommended to further improve source isolation, to prevent the sources from modulating each other and generating intermodulation products.

Spectrum analyzers can produce significant internal distortion products if they are overdriven. Generally, spectrum analyzers are designed to operate at their best with about -30dBm to -40dBm at their input. Sufficient spectrum analyzer input attenuation should be used to avoid saturating the instrument.

Before performing measurements on the DUT, the system performance should be evaluated to ensure that: 1) a clean input signal is obtained and 2) the spectrum analyzer internal distortion is minimized.

3. Connect DC power supply negative (-) output to demo board GND pin.
4. Connect DC power supply positive (+) output (4.5V to 5.25V) to demo board Vcc pin.

NOTE: Do not exceed 5.5V, the absolute maximum supply voltage.

5. Using a jumper cable, connect demo board Vcc pin to EN pin. Now the detector is enabled (on) and is ready for measurement.

QUICK START GUIDE FOR DEMONSTRATION CIRCUIT 933A

HF/VHF/UHF DOWNCONVERTING MIXER

NOTE: Make sure that the power is not applied to the EN pin before it is applied to the Vcc pin. The voltage on the EN pin must never exceed the voltage on the Vcc pin +0.3V.

6. Apply RF and LO input signals to perform AC measurements.

NOTE: Do not exceed the absolute maximum RF and LO input power.

7. Set the LO signal generator (#1) to provide a 150MHz, -5dBm, CW signal to the demo board LO input port.
8. Set the RF signal generators (#2 and #3) to provide two -10dBm CW signals to the demo board RF input port—one at 139.9MHz, and the other at 140.1MHz.
9. Set the Spectrum Analyzer's frequency range to capture the 10MHz IF output. Sufficient spectrum analyzer input attenuation should be used to avoid saturating the instrument.

10. Conversion gain and Input 3rd order intercept can be measured:

- a. $G_c = P_1 - P_{in}$
- b. $IIP3 = (P_1 - P_3) / 2 + P_{in}$

Where P_1 is the power level of the fundamental output tone at 9.9MHz or at 10.1MHz, P_3 is the 3rd order product at 9.7MHz or at 10.3MHz, and P_{in} is the input power (in this case, -10dBm). All units are in dBm.

11. Measure RF to LO isolation, LO leakages, and Input 1dB compression.
12. Single-Sideband Noise Figure can be measured on a noise figure meter. Refer to noise figure meter manual for instructions. Be sure to use a high quality signal generator and a band-pass filter on the LO input. A band-pass filter on the RF input port is required for image suppression.

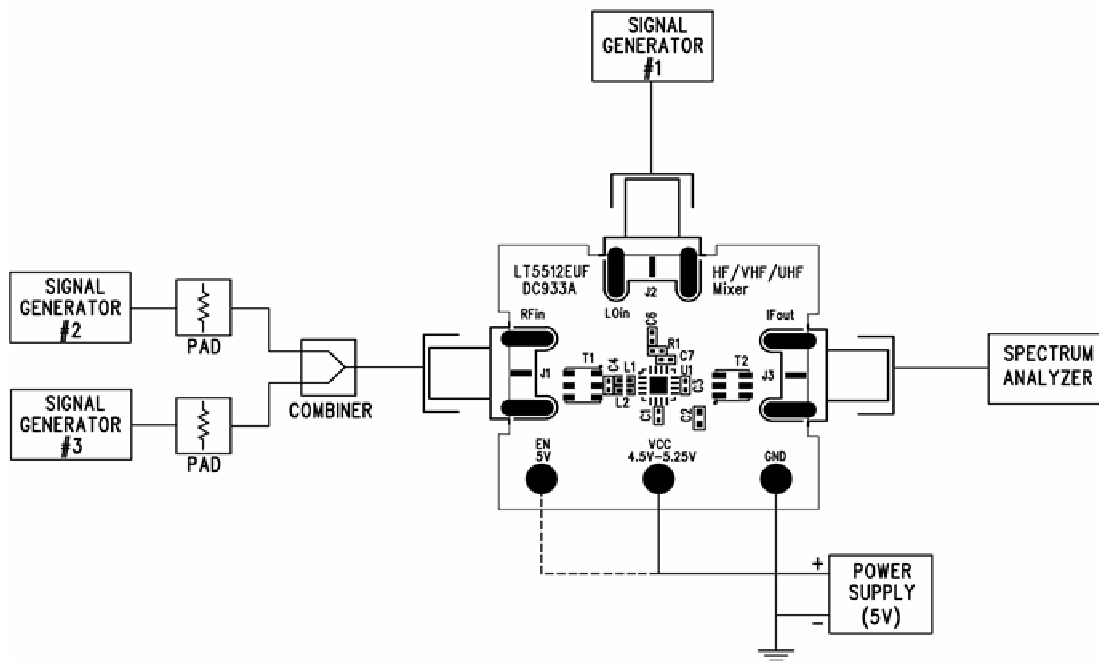

Figure 1. Proper Measurement Equipment Setup



Компания «ЭлектроПласт» предлагает заключение долгосрочных отношений при поставках импортных электронных компонентов на взаимовыгодных условиях!

Наши преимущества:

- Оперативные поставки широкого спектра электронных компонентов отечественного и импортного производства напрямую от производителей и с крупнейших мировых складов;
- Поставка более 17-ти миллионов наименований электронных компонентов;
- Поставка сложных, дефицитных, либо снятых с производства позиций;
- Оперативные сроки поставки под заказ (от 5 рабочих дней);
- Экспресс доставка в любую точку России;
- Техническая поддержка проекта, помощь в подборе аналогов, поставка прототипов;
- Система менеджмента качества сертифицирована по Международному стандарту ISO 9001;
- Лицензия ФСБ на осуществление работ с использованием сведений, составляющих государственную тайну;
- Поставка специализированных компонентов (Xilinx, Altera, Analog Devices, Intersil, Interpoint, Microsemi, Aeroflex, Peregrine, Syfer, Eurofarad, Texas Instrument, Miteq, Cobham, E2V, MA-COM, Hittite, Mini-Circuits, General Dynamics и др.);

Помимо этого, одним из направлений компании «ЭлектроПласт» является направление «Источники питания». Мы предлагаем Вам помощь Конструкторского отдела:

- Подбор оптимального решения, техническое обоснование при выборе компонента;
- Подбор аналогов;
- Консультации по применению компонента;
- Поставка образцов и прототипов;
- Техническая поддержка проекта;
- Защита от снятия компонента с производства.



Как с нами связаться

Телефон: 8 (812) 309 58 32 (многоканальный)

Факс: 8 (812) 320-02-42

Электронная почта: org@eplast1.ru

Адрес: 198099, г. Санкт-Петербург, ул. Калинина, дом 2, корпус 4, литера А.