

Motor Solutions Guide



Premier Energy-Saving Solutions Using Toshiba's semiconductors for Motor Applications

Toshiba's semiconductor devices help reduce the power consumption, reduce the size and thickness, and improve the efficiency of motor applications, contributing to the development of eco-friendly systems.

Now, energy-saving is a global issue.

The requirements for semiconductor devices for home appliance, mobile and industrial applications include high efficiency, fast response, low loss, a high level of safety, and superb environmental performance.

To meet these requirements, Toshiba offers an extensive portfolio of semiconductor devices, including vector control MCUs, high-efficiency, high-current stepping motor drivers with a current rating of up to 5.0 A, motor drivers (intelligent power devices) fabricated using a high-voltage process, and brushless DC (BLDC) motor drivers that help reduce the acoustic noise generated by motors.

Toshiba's semiconductor devices for motor applications help realize the ideal eco-friendly systems.



Contents	
Applications	Home Appliances and Consumer Electronics 4
	Mobile and Compact Equipment 6
	Office Equipment 8
	Industrial Applications 10
Products	Brushless Motor Drivers 12
	Brushed Motor Drivers 14
	Stepping Motor Drivers 16
	Transistor Arrays 18
	Microcontrollers 19
	Motor Drivers (Intelligent Power Devices) 22
	Photocouplers 23

This catalog contains the latest information available as of November 12, 2014.

Home Appliances and Consumer Electronics

Toshiba offers a suite of motor solutions suitable for DC inverter applications that require low power consumption and quiet motor control. Our product portfolio includes motor controllers, motor drivers, microcontrollers with an integrated vector engine, intelligent power devices (IPDs), IGBTs and photocouplers.

Application Example: Air Conditioner

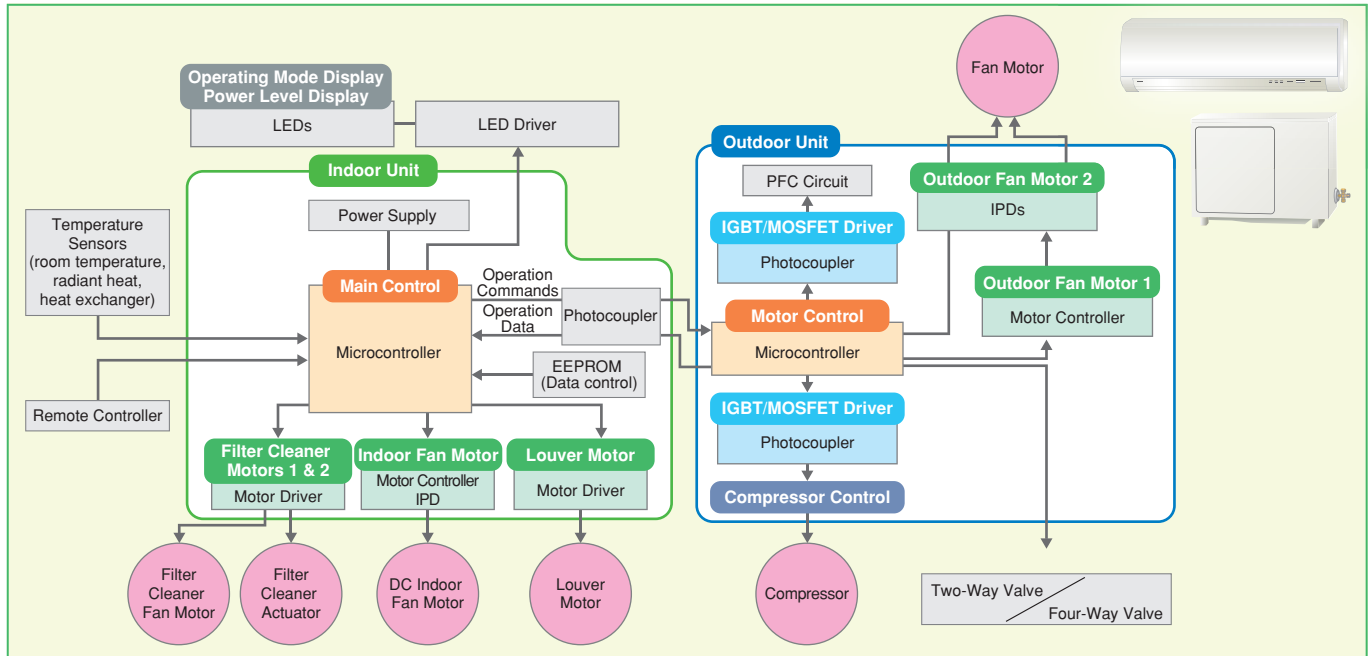

Product Lineup

Applications	Semiconductor	Recommended Devices	Features	End-Product Examples
Motor Control	Microcontrollers	TMPM370, TMPM372 TMPM373, TMPM374 TMPM375, TMPM376	Vector Engine (VE) Vector Engine Plus (VE+) (only TMPM375) 3-phase PWM (2 channels for TMPM370 and TMPM376)	Refrigerators, air conditioners, automatic washing machines, dishwashers
Main Control	Microcontrollers	TMPM380, TMPM384	Multipurpose timer for motor and IGBT control	
Indoor Fan Motor	Motor Controllers/Drivers	TB67B000HG	Brushless DC motor driver; sine-wave current control	
		TB6584FNG/AFNG, TB6551FAG TB6631FNG, TB6634FNG	Brushless DC motor controller; sine-wave current control	
		TB6586FG/AFG/BFG	Brushless DC motor controller	
Outdoor Fan Motor	Motor Controllers/Drivers	TB67B000HG	Brushless DC motor driver; sine-wave current control	
		TB6584FNG/AFNG, TB6551FAG TB6631FNG, TB6634FNG	Brushless DC motor controller; sine-wave current control	
		TB6586FG/AFG/BFG	Brushless DC motor controller	
Indoor Louver Motor	Motor Controllers/Drivers	TB62210FNG, TB62211FNG TC78S600FTG/FNG	Two-phase stepping motor driver	
		TB62261FTAG/FTG TB62262FTAG/FTG, TB6608FNG		
		TC78H600FTG/FNG, TB6552FTG/FNG TC78H610FNG	Full-bridge driver for a brushed DC motor	
Indoor Filter Cleaner Motor 1	Motor Controllers/Drivers	TB6585FG/AFTG	Brushless DC motor driver; sine-wave current control	
Indoor Filter Cleaner Motor 2	Motor Controllers/Drivers	TB6608FNG, TC78S600FTG/FNG	Stepping motor driver; 4-bit microstepping	
Air Conditioners Indoor Fan Motors	Motor drivers (Intelligent power devices)	TPD4151K, TPD4142K	Thin package High-voltage, high-current pins and control pins are isolated on the opposite sides of a package.	Air conditioners
Air Conditioners Outdoor Fan Motors	Motor drivers (Intelligent power devices)	TPD4123K/AK, TPD4144K/AK TPD4135K/AK		
Compressor Control	Motor drivers (Intelligent power devices)	TPD4135K/AK		Refrigerators
Compressor Drive Pulsator/Drum Drive	IGBTs	GT15J341, GT20J341, GT30J121 GT30J341	Low loss; available in insulated and non-insulated packages	Air conditioners, automatic washing machines, hand dryers
Circulating Pumps	Motor drivers (Intelligent power devices)	TPD4144K/AK	Thin package, High-voltage, high-current pins and control pins are isolated on the opposite sides of a package.	Automatic washing machines, dishwashers
IGBT and Power MOSFET Drivers for Compressor Applications	Photocouplers	TLP155E, TLP152 TLP5751, TLP5214	Direct drive of an IGBT or a power MOSFET Peak output current: 0.6 A to 4.0 A Small low-cost SO6: 0.6-A output (TLP155E), 2.5-A output (TLP152) Isolation voltage: 5 kVrms rail-to-rail output TLP5751 in SO6L TLP5214 with overcurrent protection features in SO16L	Air conditioners, refrigerators

Toshiba's Unique Technologies

Motor drivers

- **Sensorless PWM drive:** The back-EMF voltage from the motor coil is sensed and fed back to the commutation signals.
- **Sine-wave drive:** The motor windings are energized with sine-wave currents to reduce vibration and acoustic noise. Sine-wave PWM control is implemented as a hardware core.
- **Lead angle control:** Lead angle control and automatic lead angle correction help to improve motor efficiency.

Microcontrollers

- **Vector control:** The hardware specifically designed for vector control enables sensorless sine-wave drive.

Product Overview

500-V Sine-Wave BLDC Motor Driver (TB67B000HG)

- High-voltage sine-wave driver (500 V/2.0 A, sine- and square-wave drive)
- Lead angle control (via an external input)
- On-chip power supply for Hall sensors and Hall ICs
- On-chip oscillator (external resistor required)
- Motor lock protection
- Current limiter
- Thermal shutdown (TSD)
- Through-hole package: HDIP30

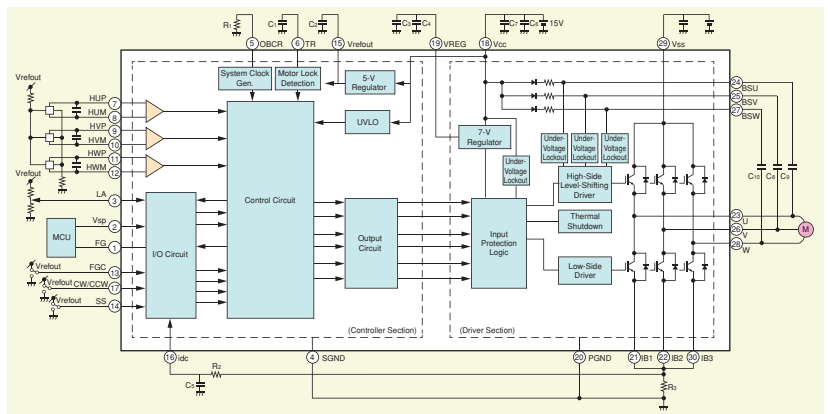

Single-Channel Stepping Motor Drivers (TC78S600FTG/FNG)

- Absolute Maximum Ratings: 18 V/1.0 A
- Half-, quarter-, 1/8- and 1/16-step drive modes
- Output Ron: 1.2 Ω typ. (high side + low side)
- Clock input control
- Constant-current PWM control
- Standby function
- Small packages: WQFN24, SSOP20

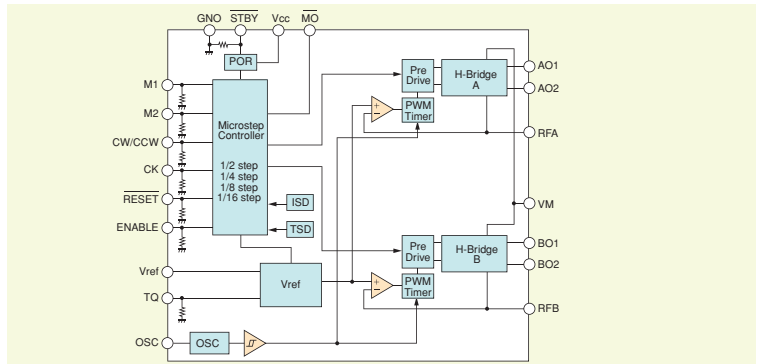

Two-Channel Brushed DC Motor Drivers (TC78H600FTG/FNG)

- Absolute Maximum Ratings: 18 V/1.0 A
- Supports direct and constant-current PWM
- Output Ron: 1.2 Ω typ. (high side + low side)
- Standby function
- Cross-conduction protection
- Small packages: WQFN24, SSOP20

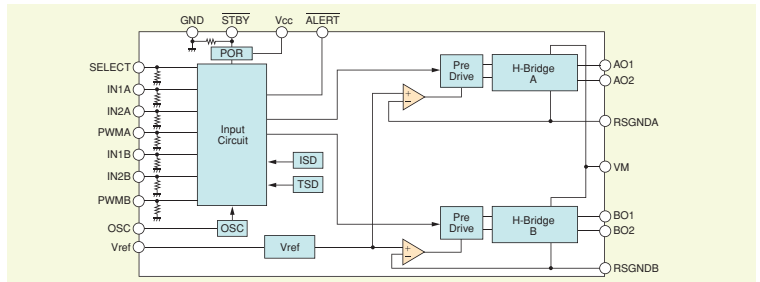

Microcontrollers with Vector Engine (TMPM370FYFG/FYDFG)

- Incorporates Toshiba's original Vector Engine (VE) that implements part of the motor vector control function in hardware
- High-performance ARM® Cortex®-M3 core with a clock rate of up to 80 MHz
- High-speed programming into Toshiba's original on-chip NANO FLASH™ memory
- Various analog circuits (comparator, op-amp)
- 12-bit AD converter
- Compliant with the IEC 60730 standard of the International Electrotechnical Commission
- 5-V single power supply

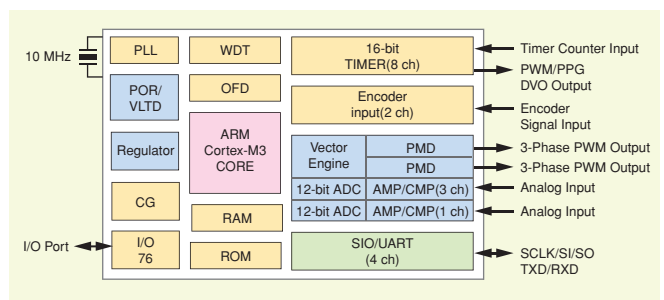

*NANO FLASH is a trademark of Toshiba Corporation.

*ARM and Cortex are registered trademarks of ARM Limited (or its subsidiaries) in the EU and/or countries elsewhere.

Mobile and Compact Equipment

Toshiba offers a portfolio of semiconductor devices ideal for mobile and compact applications requiring low power consumption and small form factor.

Application Example: Surveillance Camera

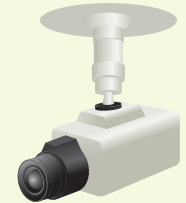
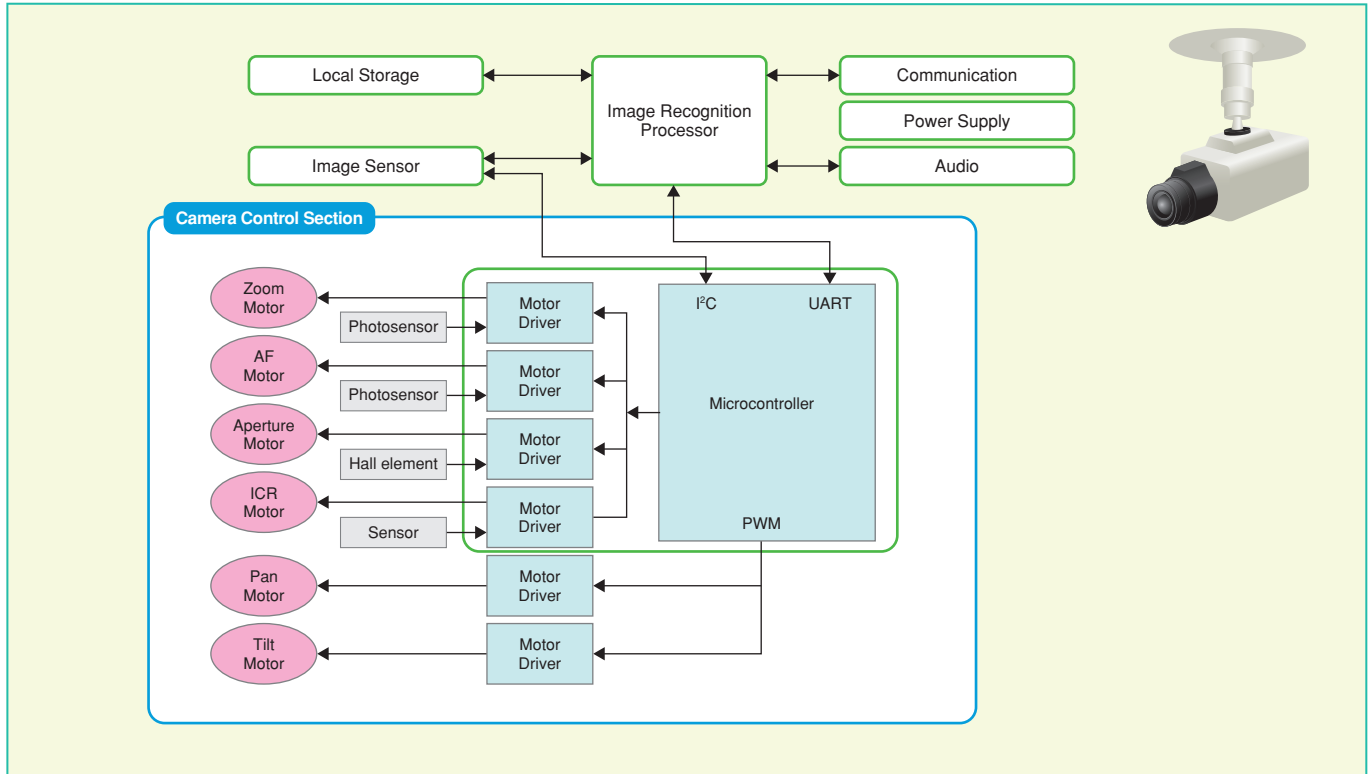

Product Lineup

Applications	Semiconductor	Recommended Devices	Features	End-Product Examples
Motor Control	Microcontrollers	TMPM341 TMPM342 TMPM343	ARM Cortex-M3 core (54 MHz max) 12-bit AD converter, 10-bit DA converter High-resolution programmable pulse generator (PPG) with a 6-ns resolution 2-phase input pulse counter Programmable servo/sequence controller (PSC) (TMPM342, TMPM343) Microstep control and H-switch driver (TMPM342, TMPM343) Analog circuits for various sensors (TMPM342, TMPM343)	Digital video cameras, digital still cameras, surveillance cameras, camera lenses
		TMPM440	ARM Cortex-M4F core (100 MHz max) 12-bit AD converter, 10-bit DA converter Improved performance thanks to multiple computing units (MAC, FPU, PSC)	Digital video cameras, digital single-lens reflex camera, surveillance cameras, home appliances, audio equipment, sensor applications, printers, communications equipment
Lens Drive Actuator Drive	Brush motor drivers/ Stepping motor drivers	TB6614FNG	Single-bridge	Digital still cameras, surveillance cameras, network ip cameras, camera lenses, small scanners, mini printers
		TB6612FNG TB6552FTG/FNG	Dual-bridge	
		TB6613FTG	8 channels, 6-bit microstepping, dual motor drive, serial interface	
		TB6608FNG	8 microsteps, constant-current drive	
		TC78S600FTG/FNG	16 microsteps, constant-current drive, maximum rated voltage: 18 V	
Pan/Tilt Drive	Stepping motor drivers	TC78H600FTG/FNG TC78H610FNG	Dual-bridge, maximum rated voltage: 18 V	
		TB62269FTG	32 microsteps, constant-current drive, maximum rated voltage: 40 V, output current: 1.8 A (max)	
		TB62212FTAG/FNG	4-channel H-bridges for driving two stepping motors	

Toshiba's Unique Technologies

Motor drivers

- Reduced power consumption due to the use of a new process technology: Products with an LDMOS output stage featuring low power consumption
- Significantly reduced power loss and heat dissipation from the output stage: TB62269FTG: Ron = 0.8 Ω typ. (high side + low side)
- Reduced vibration due to the use of a high-resolution microstep sine-wave driver: TB62269FTG: 32 microsteps
- Small packages: Leadless WQFN packages

Microcontrollers

- Programmable servo/sequence controller (PSC): MCU with Toshiba's original coprocessor specifically designed for computing operations
- Ultrasonic-motor control and piezoelectric actuator support: PPG outputs with 6-ns resolution.

Product Overview

Motor Control Microcontroller (TMPM342FYXBG)

The TMPM342FYXBG incorporates analog circuits required for camera shake correction, lens control and overall system control. The high-performance ARM Cortex-M3 core provides high-speed computation. Additionally, a high-resolution programmable phase generator (PPG) enables smooth and quiet motor operation.

- ARM Cortex-M3 core
 - Supply voltage: 2.7 to 3.6 V (regulated on-chip)
 - Maximum operating frequency: 40 MHz
 - On-chip memory: 256-KB Flash ROM, 32-KB SRAM
- Motor driver
 - Operating voltage: 2.5 V to 5.5 V max (with the driver on), 3.1 V to 3.5 V (peripheral analog blocks)
- On-chip peripherals
 - PSC: 2 KB (instruction) + 2 KB (data) per unit
 - 16-bit delta-sigma AD converter: 1 unit (4 differential channels)
 - 12-bit AD converters: 2 units (8 channels + 4 channels)
 - 10-bit DA converter: 2 channels
 - DMA controller: 4 channels
 - 16-bit timer: 8 high-speed channels + 10 channels
 - Two-phase input pulse counter: 2 channels
 - H-switch driver: 7.5 channels (plus two 7-bit microstep controllers)
 - Hall Bias Control: 2 units
 - Op-amp: 6 channels
 - PI-PE interface: 2 channels
 - 10-bit electrical variable resistance (EVR): 2 units
- Package: VFBGA142

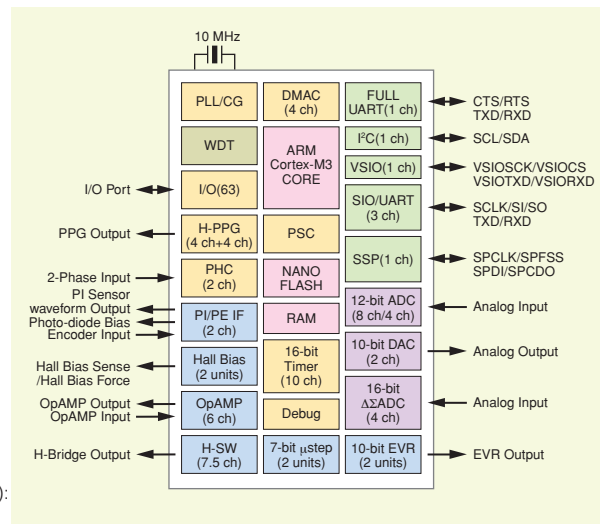

Abbreviations: PI: Photo Interrupter PE: Photo Encoder

Low-Voltage Stepping Motor Drivers (TC78S600FTG/FNG)

The TC78S600FTG/FNG supports half-, quarter-, 1/8- and 1/16-step motor drive modes, and forward/reverse direction control.

- Motor supply voltage (VM): 15 V max
- Control supply voltage (Vcc): 2.7 V to 5.5 V (operating range)
- Output current (Iout): 0.8 A max
- Output Ron: 1.2 Ω typ. (high side + low side)
- Microstep control circuit (with a clock input)
- Half-, quarter-, 1/8- and 1/16-step drive modes
- Internal pulldown resistors on input pins: 200 kΩ typ.
- Monitor output (MO) pin
- Overcurrent detection (ISD), thermal shutdown (TSD), undervoltage lockout (UVLO)
- Packages: WQFN24, SSOP20

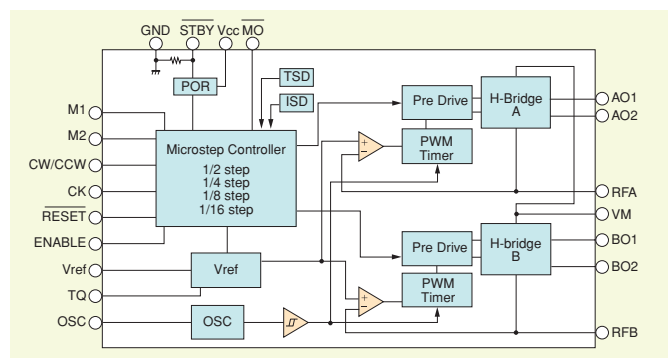

PWM Bipolar Stepping Motor Driver (TB62269FTG)

The TB62269FTG is rated at 40 V/1.8 A. The internal voltage regulator allows control of a motor with a single VM power supply.

- Single-chip drive control of a bipolar stepping motor
- PWM constant-current drive
- Full-, half-, quarter-, 1/8-, 1/16- and 1/32-step drive modes
- Low output Ron due to a BiCD process: 0.8 Ω typ. (high side + low side)
- Thermal shutdown (TSD), overcurrent detection (ISD), VM power-on reset (POR)
- Operates with only the VM power supply because of the on-chip Vcc regulator for internal circuitry
- Chopping frequency programmable via external resistor and capacitor
- Package: WQFN48

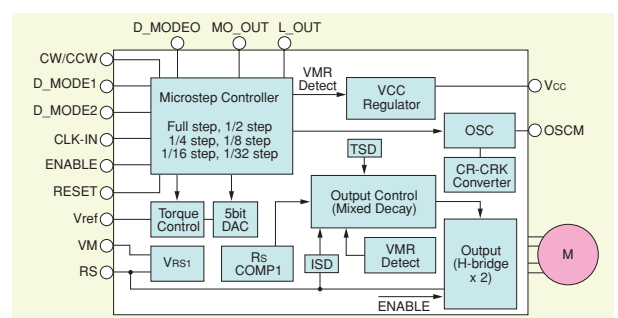

Office Equipment

Toshiba offers various semiconductor devices for motor applications that embody its unique motor control technologies. These devices make it possible to optimize high-precision, high-speed motor control for office equipment applications.

Application Example: Printer

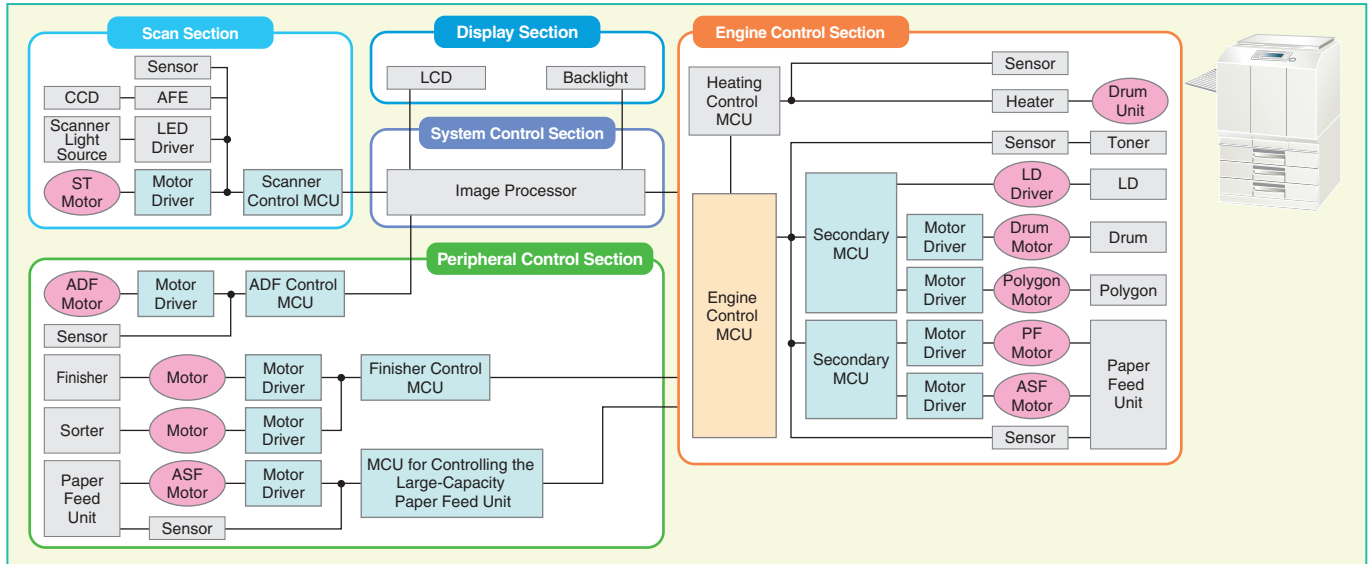

Product Lineup

Applications	Semiconductor	Recommended Devices	Features	End-Product Examples
Engine Control Section	Microcontrollers	TMPM362	ARM Cortex-M3 core (64 MHz max), 18 serial channels, Sixteen 16-bit timer channels, Consumer Electronics Control (CEC) interface, remote control preprocessor	Multifunction printers, printers, audio-visual (AV) equipment, digital equipment, PC peripherals, industrial equipment, networking equipment, office equipment
		TMPM369	ARM Cortex-M3 core (80 MHz max), multipurpose timer suitable for various motor and IGBT control, USB, USB Embedded Host, dual AD converter, programmable motor driver (PMD), CAN, EtherMAC	
		TMPM461 TMPM462	ARM Cortex-M4F core (120 MHz max), multipurpose timer suitable for various motor and IGBT control, 3 DMA units, 20 serial channels, CEC interface, remote control preprocessor, large-capacity memory	
	Brush Motor Drivers	TB6568KQ, TB6643KQ	Single full bridge, direct PWM control	
		TB6569FTG/FG, TB6641FTG/FG TB67H301FTG/FNG** TB67H400AFTG/FNG/FG**/HG/NG	Single full bridge, emergency output, Direct PWM control, Constant-current PWM control Direct PWM control, Constant-current PWM control, Standby function Dual full bridge, Constant-current PWM control, Direct PWM control, Parallel control of two channels (Large mode)	
Scanner Peripheral Control Section	Microcontrollers	TMPM037	ARM Cortex-M0 core (20 MHz max), 1 DMA unit, bit-banding	Multifunction printers, printers, audio-visual (AV) equipment, digital equipment, PC peripherals, industrial equipment, networking equipment, office equipment
		TMPM36B	ARM Cortex-M3 core (80 MHz max), multipurpose timer suitable for various motor and IGBT control, PMD, 2 DMA units, remote control preprocessor	
		TMPM330	ARM Cortex-M3 core (40 MHz max), CEC interface, remote control preprocessor	
		TMPM361	ARM Cortex-M3 core (64 MHz max), CEC interface, remote control preprocessor, large-capacity memory	
		TMPM461 TMPM462	ARM Cortex-M4F core (120 MHz max), multipurpose timer suitable for various motor and IGBT control, 3 DMA units, 20 serial channels, CEC interface, remote control preprocessor, large-capacity memory	
	Stepping Motor Drivers (Bipolar)	TB6560AFTG/FG/HQ	Clock input, micro-stepping drive (1/16 step)	Plain paper copiers (PPCs), printers, fax machines, vending machines, ATMs, amusement equipment, card readers, bank note recognition machines, etc.
		TB62211FNG, TB62214AFTG/FNG/FG TB62215AFTG/FNG/FG/HQ, TB62262FTAG/FTG	Clock input, micro-stepping drive (1/4 step)	
		TB67S102AFTG/FNG/FG**/HG**/NG	Clock input, micro-stepping drive (1/4 step), ADMD	
		TB62210FNG, TB6562AFNG/NG TB62218AFTG/FNG/FG TB62213AFTG/FNG/FG/HQ, TB62261FTAG/FTG/SFG	Phase inputs, micro-stepping drive (1/4 step)	
		TB67S101AFTG/FNG/FG**/HG**/NG	Phase inputs, micro-stepping drive (1/4 step), ADMD	
		TB62269FTG	Clock input, micro-stepping drive (1/32 step)	
		TB67S141FTG/FG**/HG/NG	Phase input interface, 84 V/3.0 A, micro-stepping drive (1/4 step)	
	Stepping Motor Drivers (Unipolar)	TB67S142FTG/FG**/HG/NG	Clock input interface, 84 V/3.0 A, micro-stepping drive (1/4 step)	
Stepping Motor Drivers/Brush Motor Drivers	TB62212FTAG/FNG	Phase inputs, micro-stepping drive (1/2 step) Four on-chip H-bridge channels allow control of either up to four brushed DC motors or up to two stepping motors.		

**: Planned **: Under development

Toshiba's Unique Technologies

Motor drivers

- Reduced power consumption due to the use of a new process:
Products with an LDMOS output stage featuring low power consumption
- Significantly reduced power loss and heat dissipation from the output stage: TB62269FTG: $R_{on} = 0.8 \Omega$ typ. (high side + low side)
- Reduced vibration due to the use of a high-resolution microstep sine-wave driver: TB62269FTG: 32 microsteps
- Small packages: Leadless WQFN packages
- High-efficiency control of a high-rpm motor: Advanced Mixed Decay (ADMD) technology

Product Overview

40-V/1.8-A Bipolar Stepping Motor Drivers (TB62261FTG, TB62262FTG, TB62269FTG)

- Full-, half-, quarter-, 1/8-, 1/16- and 1/32-step drive modes
- Low output R_{on} due to a BiCD process: 0.8Ω typ. (high side + low side)
- Thermal shutdown (TSD), overcurrent detection (ISD), VM power-on reset (POR)
- Supports a clock input and a phase-input interface
- Package: WQFN48

84-V/3.0-A Unipolar Stepping Motor Drivers (TB67S141FTG/FG⁺⁺/HG/NG, TB67S142FTG/FG⁺⁺/HG/NG, TB67S149FTG/FG⁺⁺/HG)

- Requires no current-sensing resistor
- Full-, half-, quarter-, 1/8-, 1/16- and 1/32-step drive modes
- Low output R_{on} due to a BiCD process: 0.25Ω typ.
- Thermal shutdown (TSD), overcurrent detection (ISD), VM power-on reset (POR)
- Supports a clock input and a phase-input interface
- Package: WQFN48, HSOP28, HZIP25, SDIP24

50-V/4.0-A Two-Channel Brushed DC Motor Drivers (TB67H400AFTG/FNG/FG⁺⁺/HG/NG)

- Configurable as an 8.0-A single-channel motor driver in Large mode
- Low output R_{on} due to a BiCD process: 0.49Ω typ. (high side + low side)
- Thermal shutdown (TSD), overcurrent detection (ISD), VM power-on reset (POR)
- Package: WQFN48, HTSSOP48, HSOP28, HZIP25, SDIP24

⁺⁺: Planned

Toshiba offers motor solutions for industrial applications that require high current, quick control and high accuracy.

Application Example: Currency Counter

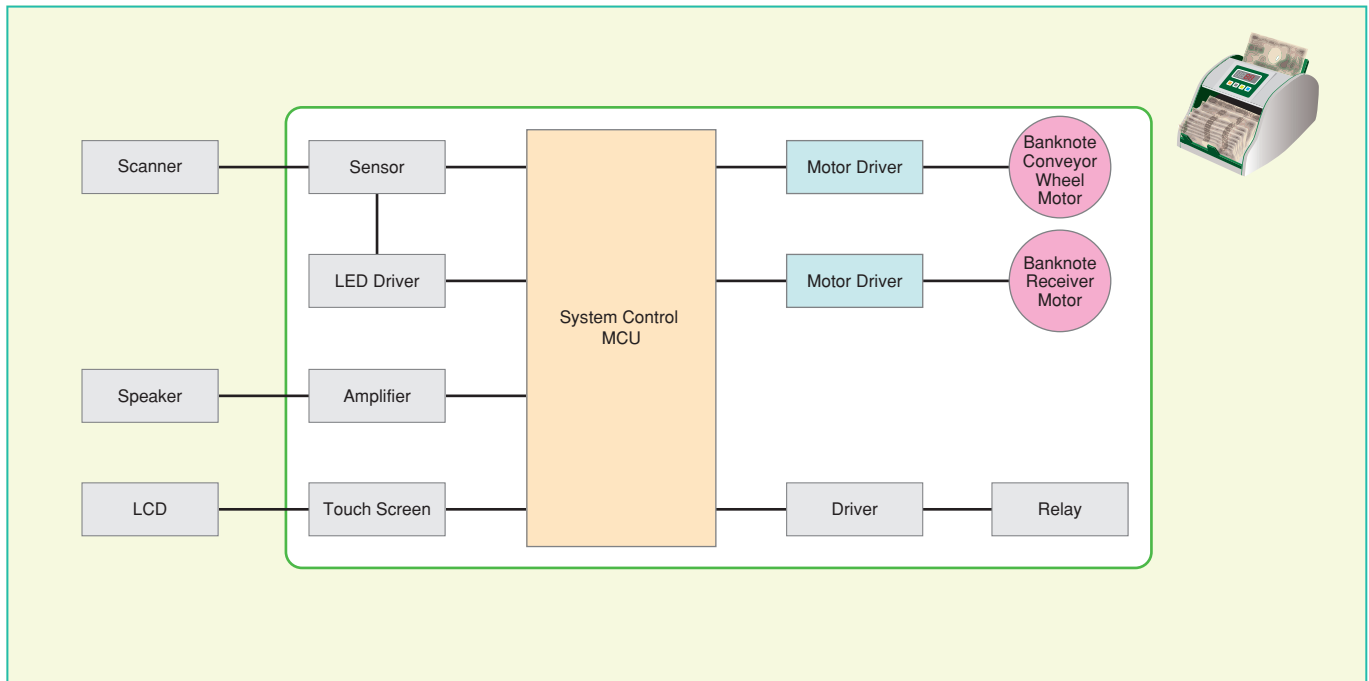

Product Lineup

Applications	Semiconductor	Recommended Devices	Features	End-Product Examples
Motor Controller	Stepping Motor Drivers (Unipolar)	TB67S141FTG/FG**/HG/NG	Phase input interface, 84 V/3.0 A, 1/4 step	Currency counters, banking terminals, industrial weaving machines, sewing machines, embroidery machines, surface-mounting machines, POS systems, ticket-vending machines, amusement equipment
		TB67S142FTG/FG**/HG/NG	Clock input interface, 84 V/3.0 A, 1/4 step	
		TB67S149FTG/FG**/HG	Clock input interface, 84 V/3.0 A, 1/32 step	
		TB67S158FTG/NG	80 V/1.5 A, 2 ch	
	Stepping Motor Drivers (Bipolar)	TB62261FTG/FTAG	Phase input interface, 40 V/1.8 A, 1/4 step	
		TB62262FTG/FTAG	Clock input interface, 40 V/1.8 A, 1/4 step	
		TB62269FTG	Clock input interface, 40 V/1.8 A, 1/32 step	
		TB67S213FTAG	Phase input interface, 40 V/2.5 A, 1/4 step	
		TB67S215FTAG	Clock input interface, 40 V/2.5 A, 1/4 step	
		TB67S101AFTG/FNG/FG**/HG**/NG	Phase input interface, 50 V/4.0 A, 1/4 step, ADMD	
		TB67S102AFTG/FNG/FG**/HG**/NG	Clock input interface, 50 V/4.0 A, 1/4 step, ADMD	
		TB67S103AFTG	Serial and clock input interfaces, 50 V/4.0 A, 1/32 step, ADMD	
		TB67S109AFTG/FNG/HG**	Clock input interface, 50 V/4.0 A, 1/32 step, ADMD	
	Brush Motor Drivers	TB6600FG/HG	Clock input interface, 50 V/5.0 A, 1/16 step	
		TB67H301FTG/FNG**	40 V/3.0 A	
		TB67H302HG	50 V/5.0 A	
		TB67H303HG	50 V/10.0 A	
	Photocouplers	TB67H400AFTG/FNG/FG**/HG/NG	50 V/4.0 A, 2 ch	
		TLP5214, TLP5754	Direct drive of an IGBT or a power MOSFET Peak output current: 4.0 A, Isolation voltage: 5 kVrms Overcurrent protection (TLP5214), rail-to-rail output (TLP5754)	
TLP2345, TLP2348		Direct IPM drive, Supply voltage: 4.5 V to 30 V High speed: 10 Mbps, Small SO6 package, active-high IPM input (TLP2345), active-low IPM input (TLP2348)		
TLP715, TLP718	Direct IPM drive, Supply voltage: 4.5 V to 20 V Isolation voltage: 5 kVrms, 5-Mbps data rate, active-high IPM input (TLP715), active-low IPM input (TLP718)			

** : Planned ** : Under development

Toshiba's Unique Technologies

Motor drivers

- Fabricated using a high-voltage and low on-resistance process: Rated at either 84 V or 50 V and provides high output current
- Synchronous rectification PWM control: Reduces power loss (heat dissipation) during PWM control.
- Various protection features help improve system safety: All motor drivers for industrial applications provide thermal shutdown (TSD), overcurrent detection (ISD) and VM power-on reset (POR).
- Available in multiple packages

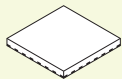

WQFN

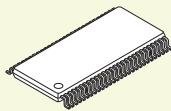

HTSSOP

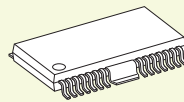

HSOP

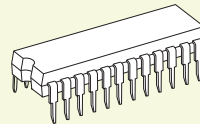

SDIP

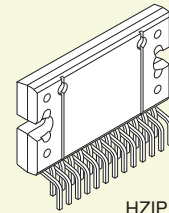

HZIP

Product Overview

84-V/3.0-A Unipolar Stepping Motor Drivers

(TB67S141FTG/FG⁺⁺/HG/NG, TB67S142FTG/FG⁺⁺/HG/NG, TB67S149FTG/FG⁺⁺/HG)

- Requires no current-sensing resistor
- Full-, half-, quarter-, 1/8-, 1/16- and 1/32-step drive modes
- Low output Ron due to a BiCD process: 0.25 Ω typ.
- Thermal shutdown (TSD), overcurrent detection (ISD), VM power-on reset (POR)
- Supports a clock input and a phase-input interface
- Packages: WQFN48, HSOP28, HZIP25, SDIP24

80-V/1.5-A Dual Unipolar Stepping Motor Drivers (TB67S158FTG/NG)

- Constant-voltage drive
- Low output Ron due to a BiCD process: 0.5 Ω typ.
- Thermal shutdown (TSD), overcurrent detection (ISD), VM power-on reset (POR)
- Supports a clock input, a serial input and a parallel-input interface
- Packages: WQFN48, SDIP24

50-V/4.0-A Two-Phase Bipolar Stepping Motor Drivers

(TB67S101AFTG/FNG/FG⁺⁺/HG^{**}/NG, TB67S102AFTG/FNG/FG⁺⁺/HG^{**}/NG, TB67S103AFTG, TB67S109AFTG/FNG/HG⁺⁺)

- High-efficiency constant-current control (Advanced Dynamic Mixed Decay)
- Full-, half-, quarter-, 1/8-, 1/16- and 1/32-step drive modes
- Low output Ron due to a BiCD process: 0.49 Ω typ. (high side + low side)
- Thermal shutdown (TSD), overcurrent detection (ISD), VM power-on reset (POR)
- Supports a clock input, a serial input and a phase-input interface
- Packages: WQFN48, HTSSOP48, HSOP28, HZIP25, SDIP24

50-V/5.0-A Bipolar Stepping Motor Drivers (TB6600FG/HG)

- Full-, half-, quarter-, 1/8- and 1/16- step drive modes
- Low output Ron due to a BiCD process: 0.4 Ω typ. (high side + low side)
- Thermal shutdown (TSD), overcurrent detection (ISD), VM power-on reset (POR)
- Supports a clock input interface
- Packages: HQFP64, HZIP25

50-V/10.0-A Large-Current Brushed DC Motor Driver (TB67H303HG)

- Low output Ron due to a BiCD process: 0.2 Ω typ. (high side + low side)
- Thermal shutdown (TSD), overcurrent detection (ISD), VM power-on reset (POR)
- Package: HZIP25

: Planned *: Under development

Brushless Motor Drivers

Brushless Motor Controller and Driver Series

Leveraging sensorless drive and sine-wave drive technologies, Toshiba has been developing a broad array of brushless DC motor drivers ideal for applications that require low power consumption and silent operation.

► Roadmap

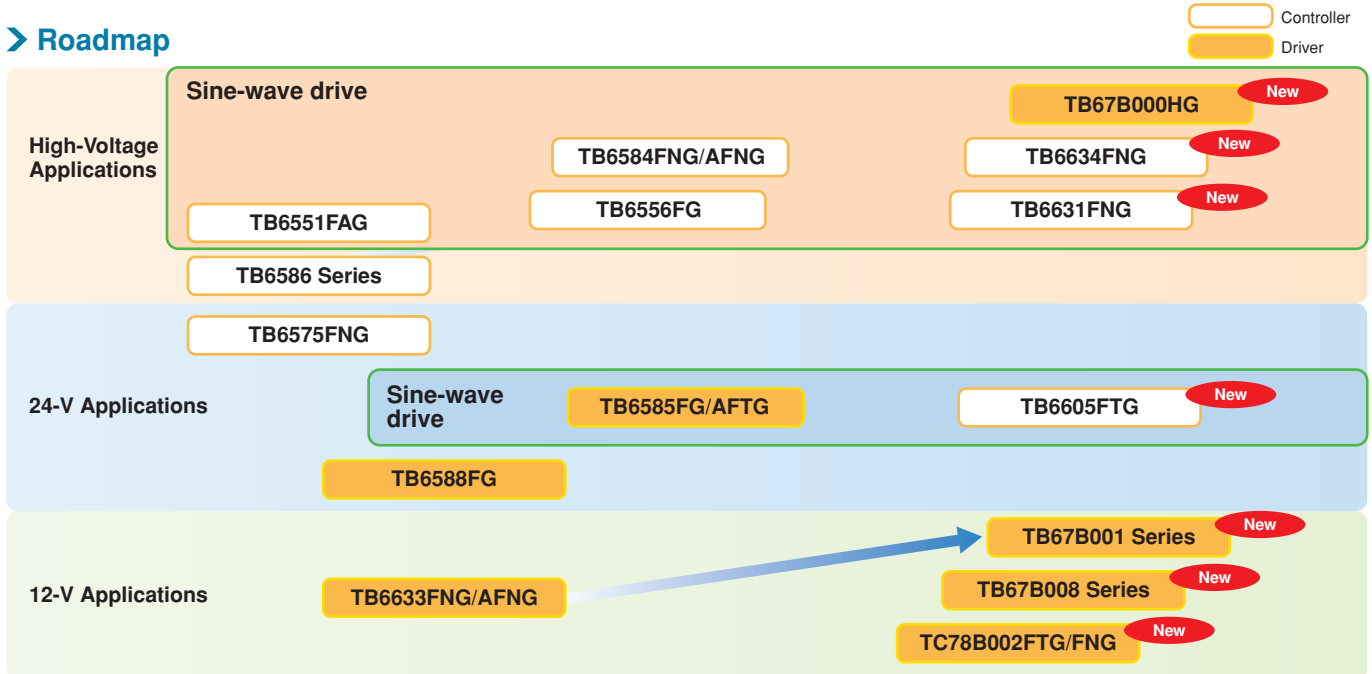

► Product Overview

500-V Sine-Wave BLDC Motor Driver (TB67B000HG)

- High-voltage sine-wave driver (Absolute Maximum Ratings: 500 V/2.0 A, sine- and square-wave drive)
- Lead angle control (via an external input)
- Motor speed control via an analog voltage input
- On-chip power supply for Hall sensors and Hall ICs
- Motor lock protection
- Through-hole package: HDIP30

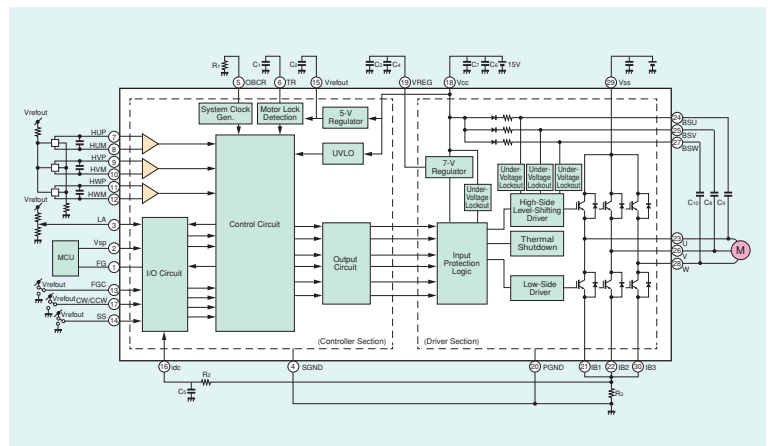

Sine-Wave Three-Phase BLDC Motor Driver (TB6605FTG)

- Ideal for use with a 12-V or 24-V power supply (Absolute maximum rating: 30 V)
- Charge pump: Designed to switch external high-side (n-channel) and low-side (n-channel) FETs
- Auto lead angle control
- Motor speed control via a PWM duty cycle input
- Motor lock protection
- Small package: QFN36

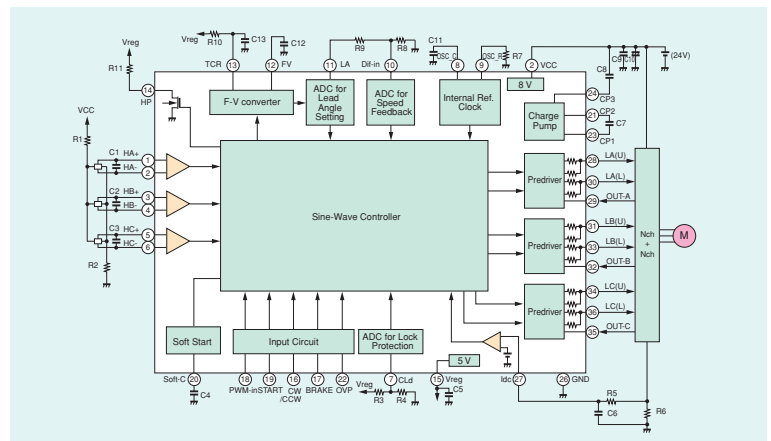

Three-Phase Sensorless BLDC Motor Drivers (TB67B001FTG/AFTG)

- Ideal for use with a 12-V power supply(Absolute maximum rating: 25 V/3.0 A)
- Supports high-rpm motors(even 30-krpm four-pole motors)
- Supports soft-switching trapezoidal commutation
- Supports auto lead angle control
- Motor speed control: Selectable from PWM duty cycle and analog voltage inputs
- Externally adjustable output duty cycle
- Motor lock protection
- Small package: QFN36

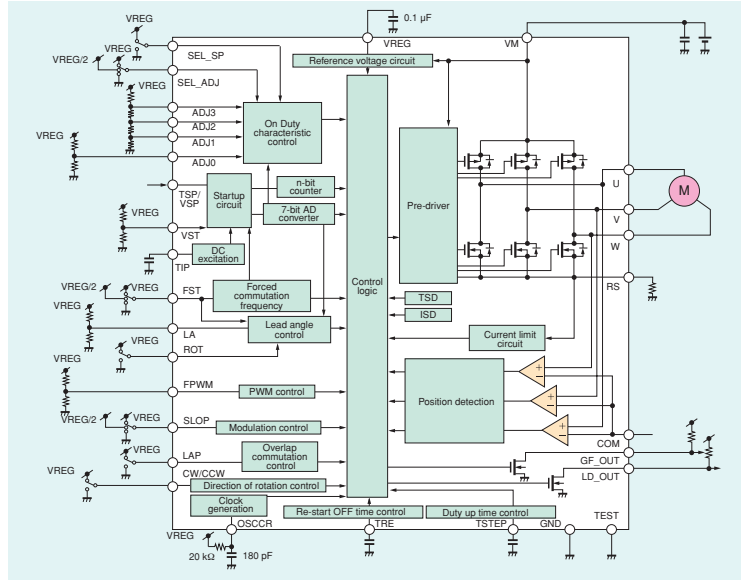

Single-Phase Pseudo-Sine-Wave BLDC Motor Driver (TC78B002FTG/FNG)

- Ideal for use with a 12-V power supply (Absolute maximum rating: 18 V/1.5 A)
- Capable of driving a BLDC motor with a sine wave by shaping the commutation waveform
- Motor speed control via an analog voltage input
- On-chip power supply for Hall sensors(and Hall-effect elements)
- Motor lock protection
- Small packages: WQFN16, SSOP16

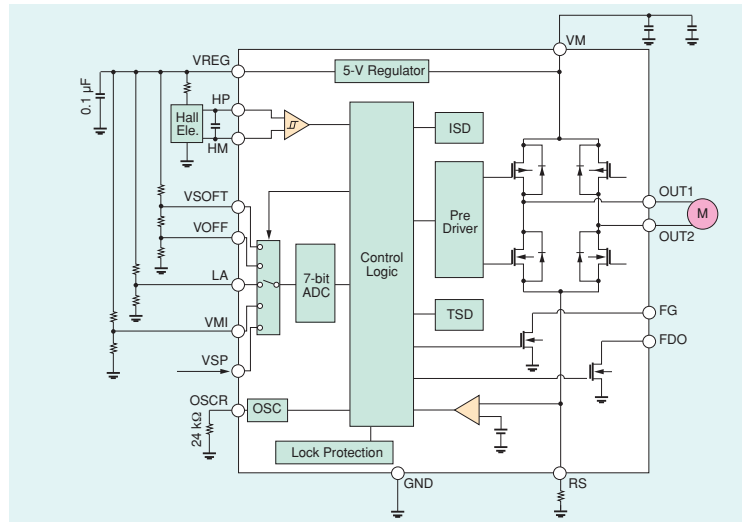

Product Lineup

Part Number	Function	Absolute Maximum Ratings		Hall Inputs	Commutation	Lead Angle Control	Packages
		Supply Voltage(V)	Output Current(A)				
TC78B002FTG/FNG	Single-phase driver	18	1.5	Hall sensors	Pseudo-sine wave	External input	WQFN16/SSOP16
TC78B006FTG**/FNG**	Single-phase predriver	40	External FET	Hall sensors	Pseudo-sine wave	External input	WQFN16/SSOP16
TB6633FNG/AFNG	Three-phase driver	25	1.0	Sensorless	Square-wave	External input	SSOP24
TB67B001FTG/AFTG	Three-phase driver	25	3.0	Sensorless	Square-wave	External input	QFN36
TB67B008FTG/AFTG/BFTG/CFTG	Three-phase driver	25	3.0	Sensorless	Square-wave	External input	WQFN24
TB67B008FNG/AFNG/BFNG/CFNG							SSOP24
TB6588FG	Three-phase driver	50	2.5	Sensorless	Square-wave	External input	HSOP36
TB6585FG	Three-phase driver	45	1.8	Hall sensors	Sine-wave	Auto (current feedback)	HSOP36
TB6585AFTG							QFN48
TB6605FTG	Three-phase predriver	30	External FET	Hall sensors	Sine-wave	Auto (rpm feedback)	QFN36
TB6575FNG	Three-phase controller	5.5	-	Sensorless	Square-wave	External input	SSOP24
TB6586FG/AFG/BFG	Three-phase controller	15	-	Hall IC	Square-wave	External input	SSOP24
TB6551FAG	Three-phase controller	12	-	Hall IC	Sine-wave	External input	SSOP24
TB6556FG	Three-phase controller	12	-	Hall IC	Sine-wave	Auto (current feedback + VSP)	SSOP30
TB6584FNG/AFNG	Three-phase controller	15	-	Hall sensors/Hall IC	Sine-wave	Auto (current feedback + VSP)	SSOP30
TB6631FNG	Three-phase controller	15	-	Hall sensors/Hall IC	Sine-wave	Auto ((rpm feedback)	SSOP30
TB6634FNG	Three-phase controller	15	-	Hall sensors/Hall IC	Sine-wave	Auto (current feedback + VSP)	SSOP30
TB67B000HG	Three-phase driver	500	2.0	Hall sensors/Hall IC	Sine-wave	External input	HDIP30
TB67Z800FTG	3-channel half-bridge	25	3.0	-	-	-	QFN36

** : Under development

Brushed Motor Drivers

Brushed DC Motor Driver Series

Toshiba offers brushed motor drivers fabricated using a BiCD process that exhibits low on-resistance and thus helps reduce power consumption. Toshiba's product portfolio contains a wide range of brushed motor drivers with extensive supply voltage, output current and channel count options. Toshiba's product offerings include motor drivers that consist of multiple H-bridges that can be combined in a flexible manner according to the types of motors driven (stepping motors and brushed DC motors) and the required current capabilities.

➤ Roadmap

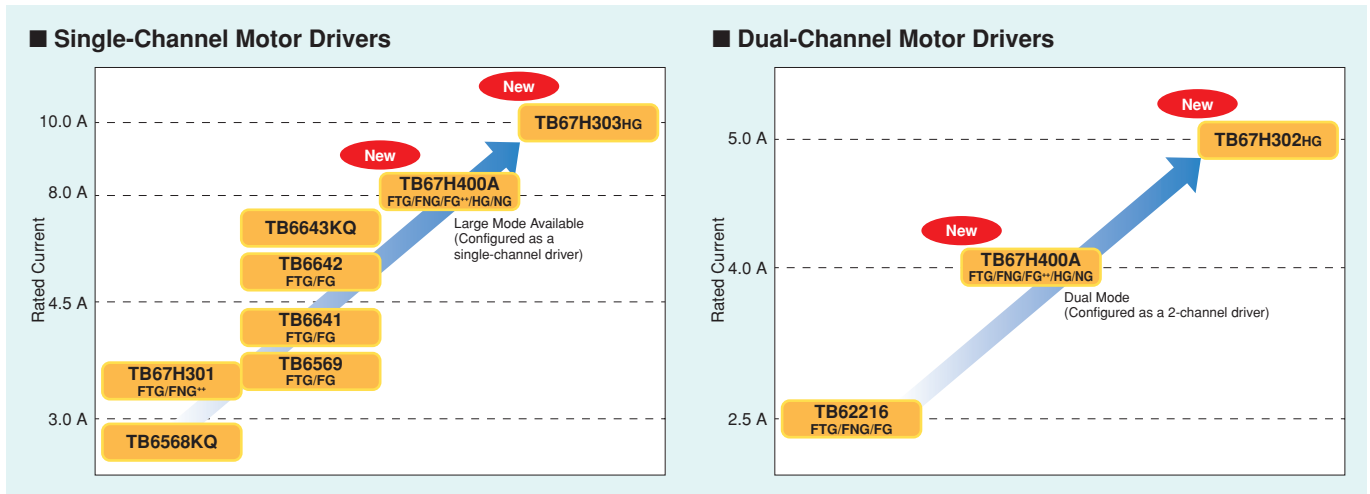

➤ Configurable Motor Drivers

The on-chip H-bridges can be configured according to the types of motors driven (stepping motors and brushed DC motors) and the required current capabilities to suit the needs of various motor applications.

● Case 1: Switching between different current capabilities

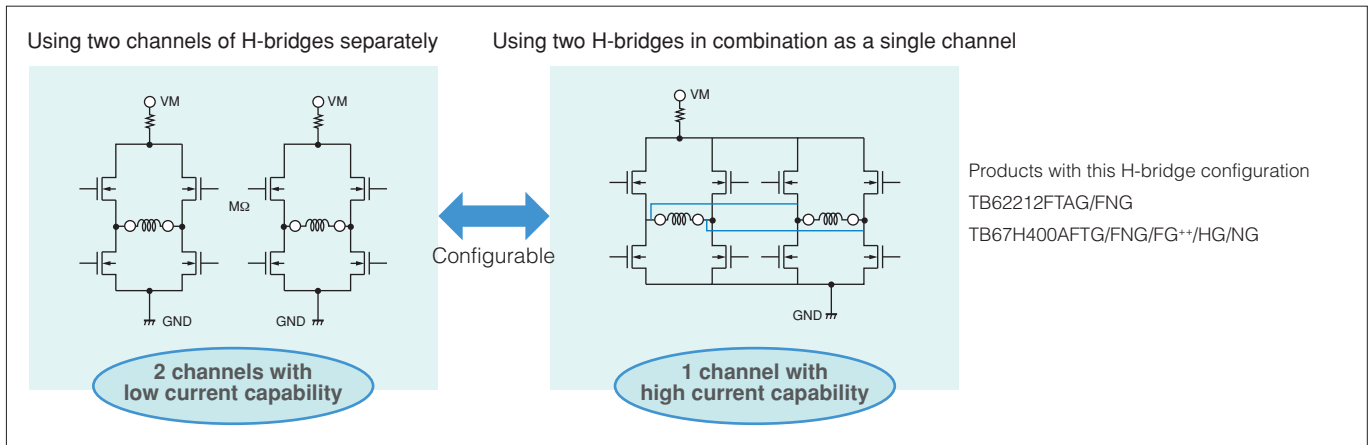

● Case 2: Selecting the types of motors to be driven

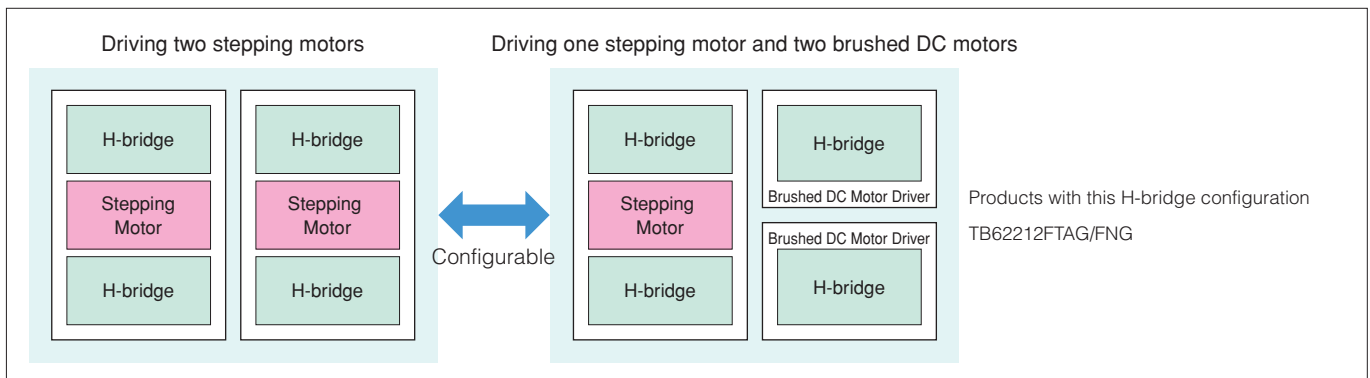

** : Planned

Brushed DC Motor Driver (TB67H303HG)

The TB67H303HG is a high-efficiency brushed DC motor driver for use with a PWM drive. Incorporating low on-resistance DMOS output drivers, the TB67H303HG can drive a motor rated at up to 50 V/10.0 A.

- Forward, reverse, short-circuit brake and stop; standby mode
- Low output Ron: 0.2 Ω typ. (high side + low side)
- Supply voltage (Vcc) = 50 V, output current (I_{OUT}) = 10.0 A (absolute maximum ratings, peak)
- Various fault detection features: Thermal shutdown (TSD), undervoltage lockout (UVLO), overcurrent detection (ISD)
- Package: HZIP25

PWM Chopper-Type Brushed DC Motor Drivers (TB67H400AFTG/FNG/FG⁺⁺/HG/NG)

Incorporating two channels of output drivers, the TB67H400A can drive up to two brushed DC motors. It can also be configured into an 8.0-A single-channel motor driver in Large mode. The TB67H400A is rated at 50 V, and 4.0 A (per channel in dual-channel mode) or 8.0 A (in single-channel Large mode).

- Low output Ron: 0.49 Ω typ. (high side + low side)
- Four operating modes: forward, reverse, short-circuit brake, stop (off)
- Various fault detection features: Thermal shutdown (TSD), overcurrent detection (ISD), VM power-on reset (POR)
- Packages: WQFN48, HTSSOP48, HSOP28, HZIP25, SDIP24

Product Lineup

Part Number	Absolute Maximum Ratings		Output Ron (H + L) (Ω)	# Circuits (ch)	Constant-Current PWM Control	Detection Circuits		Packages
	Supply Voltage (V)	Output Current (A)				ISD	TSD	
TB6568KQ	50	3.0	0.55	1	–	Y (Latch)	Y (Latch)	HSIP7
TB6643KQ	50	4.5	0.55	1	–	Y (Latch)	Y (Latch)	HSIP7
TB6559FG	50	2.5	1.3	1	Y	Y (Auto)	Y (Auto)	HSOP16
TB6617FNG	50	2.0	1.4	1	–	Y (Auto)	Y (Auto)	SSOP16
TB6569FTG/FG	50	4.5	0.55	1	Y	Y (Latch)	Y (Latch)	VQFN32/HSOP16
TB6641FTG/FG	50	4.5	0.55	1	Y	Y (Latch)	Y (Latch)	VQFN32/HSOP16
TB6642FTG/FG	50	4.5	0.55	1	–	Y (Latch/Auto)	Y (Latch/Auto)	VQFN32/HSOP16
TB6640FTG/AFTG	40	3.0	1.0	1	Y	Y (Latch/Auto)	Y (Latch/Auto)	WQFN48
TB67H301FTG/FNG ⁺⁺	40	3.0	1.0	1	Y	Y (Latch/Auto)	Y (Latch/Auto)	WQFN24/HTSSOP24
TB67H303HG	50	10	0.2	1	Y	Y (Latch)	Y (Latch)	HZIP25
TB6561NG/FG	40	1.5	1.5	2	–	Y (Auto)	Y (Auto)	SDIP24/SSOP30
TB62216FTG/FNG/FG	40	2.5	1.0	2	Y	Y (Latch)	Y (Latch)	QFN48/HTSSOP48/HSOP28
TB62212FTAG/FNG	40	4.0 (2 ch) 2.0 (4 ch)	2.2	2 4	Y	Y (Latch)	Y (Latch)	QFN48/HTSSOP48
TB67H302HG	50	5.0	0.4	2	Y	Y (Latch)	Y (Latch)	HZIP25
TB67H400AFTG/FNG/FG ⁺⁺ /HG/NG	50	8.0 (1 ch) 4.0 (2 ch)	0.49	1 2	Y	Y (Latch)	Y (Latch)	WQFN48/HTSSOP48/HSOP28/ HZIP25/SDIP24
TB6552FTG/FNG	15	1.0	1.5	2	–	–	Y (Auto)	WQFN16/SSOP16
TB6593FNG	15	3.2	0.35	1	–	–	Y (Auto)	SSOP20
TB6612FNG	15	3.2	0.5	2	–	–	Y (Auto)	SSOP24
TB6614FNG	15	3.2	0.3	1	–	Y (Auto)	Y (Auto)	SSOP16
TC78H600FTG/FNG	18	1.0	1.2	2	Y	Y (Latch)	Y (Auto)	WQFN24/SSOP20
TC78H610FNG	18	1.0	1.2	2	–	Y (Latch)	Y (Auto)	SSOP16

Abbreviations: ISD: Overcurrent detection, TSD: Thermal shutdown

**: Planned

Stepping Motor Drivers

Stepping Motor Driver Series

Toshiba offers an extensive lineup of stepping motor drivers fabricated using a BiCD process that provides high accuracy and high-current capability. Toshiba's stepping motor drivers are available in bipolar and unipolar configurations.

Roadmap

Bipolar
 Unipolar

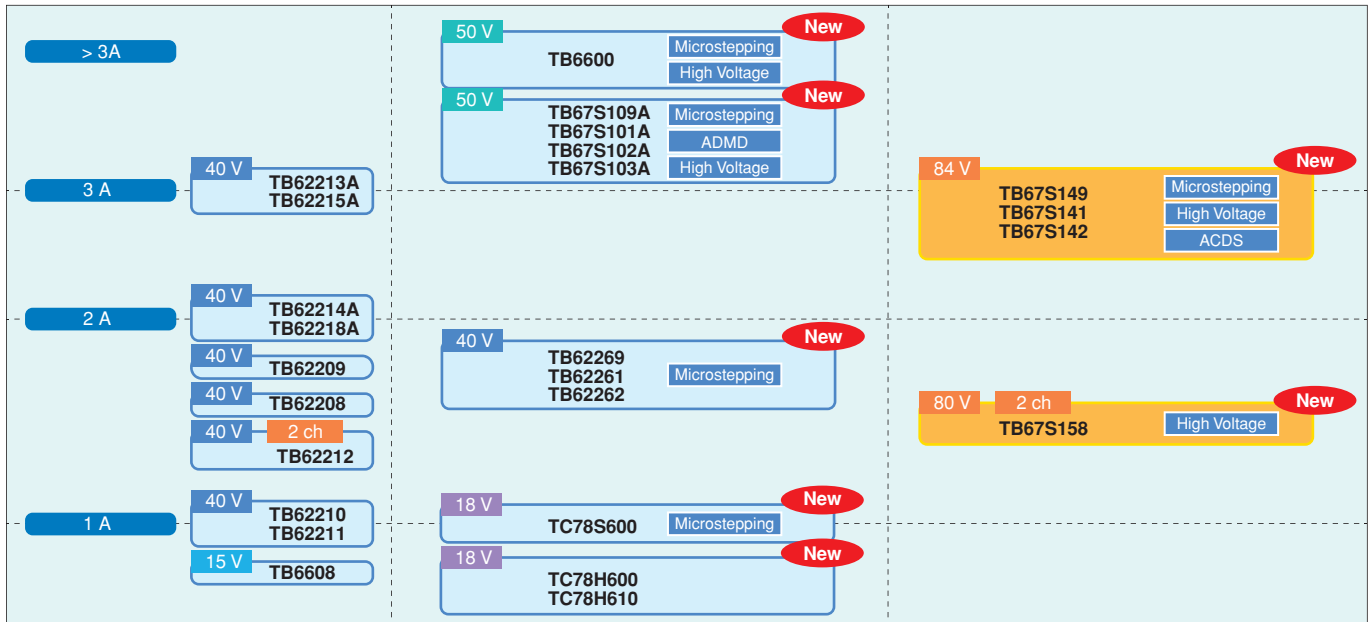

Features of Toshiba's Stepping Motor Drivers

Extensive product lineup

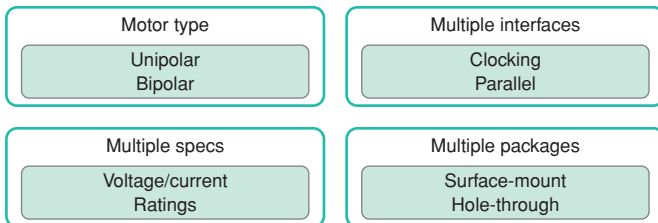

Solutions for customers' needs and issues based on leading-edge technologies

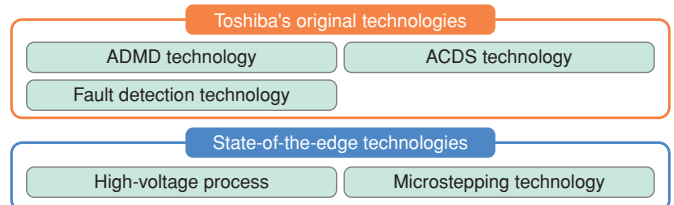

Toshiba's Original Technologies

1. Advanced Dynamic Mixed Decay (ADMD) Technology

Toshiba's original ADMD technology tracks input current more closely than the conventional mixed-decay mode, making highly efficient motor control possible at high rpm.

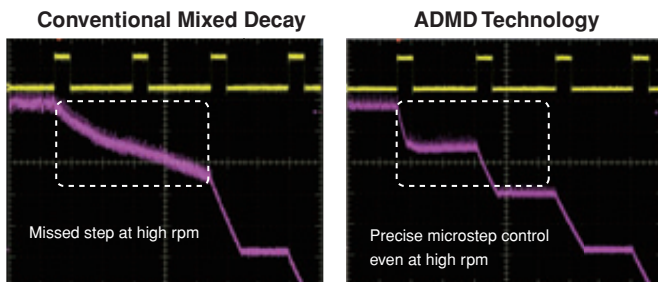

Products incorporating the ADMD technology:

- TB67S101AFTG/FNG/FG**/HG**/NG
- TB67S102AFTG/FNG/FG**/HG**/NG
- TB67S103AFTG
- TB67S109AFTG/FNG/HG**

2. Advanced Current Detect System (ACDS) Technology

Toshiba's original ACDS technology enables motor drive with highly accurate constant current without requiring external current-sensing resistors.

The reduced part count also helps reduce the board area and the bill-of-material (BOM) cost.

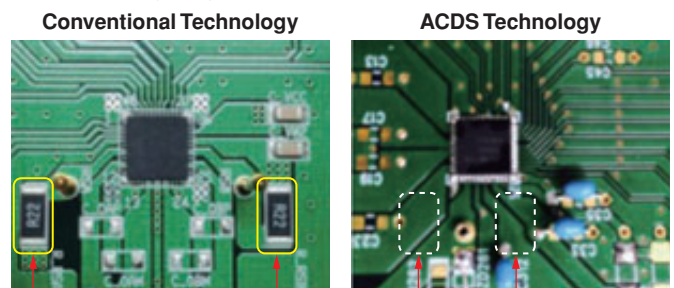

Two resistors with high electrical ratings are necessary.

No external resistor is required.

Products incorporating the ACDS technology

- TB67S141FTG/FG**/HG/NG
- TB67S142FTG/FG**/HG/NG
- TB67S149FTG/FG**/HG

**: Planned **: Under development

3. High-Voltage Analog Process Technology

Fabricated using a state-of-the-art high-voltage analog process (130-nm BiCD process), Toshiba's stepping motor drivers combine low-voltage control circuitry with high-voltage DMOS output drivers on the same monolithic structure. Consequently, high-voltage motor drivers rated at 84 V can be housed in the small WQFN48 (7 mm × 7 mm) package, which helps reduce the solution size.

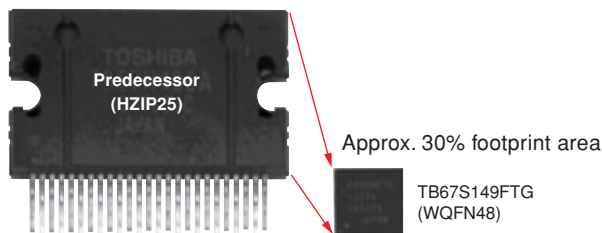

[Products fabricated with the 130-nm BiCD process]

- Maximum rated voltage: 40 V
TB62261, TB62262, TB62269, TB67S213, TB67S215
- Maximum rated voltage: 50 V
TB6600, TB67S101A, TB67S102A, TB67S103A, TB67S109A
- Maximum rated voltage: 80 V
TB67S158
- Maximum rated voltage: 84 V
TB67S141, TB67S142, TB67S149

4. Package Lineup

Toshiba's stepping motor drivers are available in various package styles, including small surface-mount and through-hole packages, that are suitable for diverse printed circuit boards, assembly methods and system applications.

➤ Product Lineup (Bipolar)

Part Number	Interface	Absolute Maximum Ratings		Stepping Mode	Detection Circuits			Packages
		Output Breakdown (V)	Output Current (A)		POR	ISD	TSD	
TB62211FNG	Clock input	40	1.0	1/4 step	✓	✓	✓	HTSSOP24
TB62262FTAG/FTG	Clock input	40	1.5(FTAG) 1.8(FTG)	1/4 step	✓	✓	✓	WQFN36/WQFN48
TB62209FG	Clock input	40	1.8	1/16 step	✓	✓	✓	HSOP36
TB62269FTG	Clock input	40	1.8	1/32 step	✓	✓	✓	WQFN48
TB62214AFTG/FNG/FG	Clock input	40	2.0	1/4 step	✓	✓	✓	QFN48/HTSSOP48/HSOP28
TB67S215FTAG	Clock input	40	2.5	1/4 step	✓	✓	✓	WQFN36
TB62215AFTG/FNG/FG/HQ	Clock input	40	3.0	1/4 step	✓	✓	✓	QFN48/HTSSOP48/HSOP28/HZIP25
TB6560AFTG/FG/HQ	Clock input	40	2.5(FTG/FG) 3.5(HQ)	1/16 step			✓	QFN48/HQFP64/HZIP25
TB67S102AFTG/FNG/FG**/HG**/NG	Clock input	50	4.0	1/4 step	✓	✓	✓	WQFN48/HTSSOP48/HSOP28/HZIP25/ SDIP24
TB67S103AFTG	Serial + clock input	50	4.0	1/32 step	✓	✓	✓	WQFN48
TB67S109AFTG/FNG/HG**	Clock input	50	4.0	1/32 step	✓	✓	✓	WQFN48/HTSSOP48/HSOP28/HZIP25
TB6600FG/HG	Clock input	50	5.0	1/16 step	✓	✓	✓	HQFP64/HZIP25
TB6608FNG	Clock input	15	0.8	1/8 step	✓		✓	SSOP20
TC78S600FTG/FNG	Clock input	18	1.0	1/16 step	✓	✓	✓	WQFN24/SSOP20
TB6674PG/FG/FAG	Phase input	24	0.4(PG/FG) 0.2(FAG)	Full step	✓	✓	✓	DIP16/HSOP16/SSOP16
TB62210FNG	Phase input	40	1.0	1/4 step	✓	✓	✓	HTSSOP24
TB6562ANG/AFG	Phase input	40	1.5	1/4 step		✓	✓	SDIP24/SSOP30
TB62206FG	Phase input	40	1.8	1/2 step	✓	✓	✓	HSOP20
TB62208FTG/FNG/FG	Phase input	40	1.8	1/4 step	✓	✓	✓	QFN48/HTSSOP48/HSOP28
TB62261FTAG/FTG	Phase input	40	1.5(FTAG) 1.8(FTG)	1/4 step	✓	✓	✓	WQFN36/WQFN48
TB62218AFTG/FNG/FG	Phase input	40	2.0	1/4 step	✓	✓	✓	QFN48/HTSSOP48/HSOP28
TB67S213FTAG	Phase input	40	2.5	1/4 step	✓	✓	✓	WQFN36
TB62213AFTG/FNG/FG/HQ	Phase input	40	3.0	1/4 step	✓	✓	✓	QFN48/HTSSOP48/HSOP28/HZIP25
TB67S101AFTG/FNG/FG**/HG**/NG	Phase input	50	4.0	1/4 step	✓	✓	✓	WQFN48/HTSSOP48/HSOP28/ HZIP25/SDIP24
TC78H610FNG	Phase input	18	1.0	1/2 step	✓	✓	✓	SSOP16
TB62212FTAG/FNG	Phase input	40	1.5 × 2 ch	1/2 step	✓	✓	✓	QFN48/HTSSOP48

➤ Product Lineup (Unipolar)

Part Number	Interface	Absolute Maximum Ratings		Stepping Mode	Detection Circuits			Packages
		Output Breakdown (V)	Output Current (A)		POR	ISD	TSD	
TB67S141FTG/FG**/HG/NG	Phase input	84	3.0	1/4 step	✓	✓	✓	WQFN48/HSOP28/HZIP25/SDIP24
TB67S142FTG/FG**/HG/NG	Clock input	84	3.0	1/4 step	✓	✓	✓	WQFN48/HSOP28/HZIP25/SDIP24
TB67S149FTG/FG**/HG	Clock input	84	3.0	1/32 step	✓	✓	✓	WQFN48/HSOP28/HZIP25
TB67S158FTG/NG	Clock input Parallel input Serial input	80	1.5 × 2 ch	1/2 step	✓	✓	✓	WQFN48/SDIP24

Abbreviations: POR: Power-on reset, ISD: Overcurrent detection, TSD: Thermal shutdown

: Planned *: Under development

Transistor Arrays

Transistor Arrays

Transistor arrays designed for stepping motor driving applications are available with a variety of functions, circuit counts, voltage and current ratings, packages and so on. Small, surface-mount SSOP packages help reduce the size of end products.

Features

- High-voltage and high-current drive
- Widely adopted in the market because of proven reliability
- Offers a robust product lineup in various packages to meet diverse customer needs

➤ Motor Drive Application Example

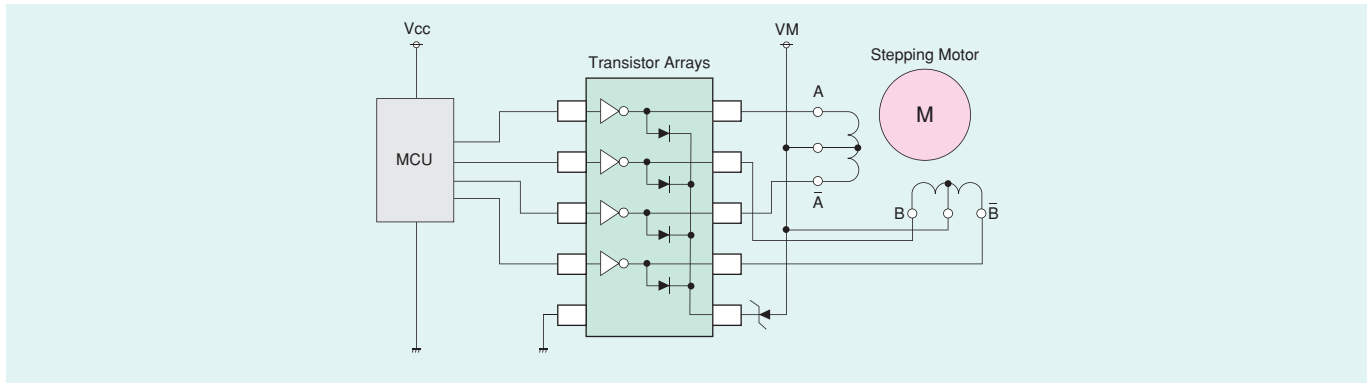

➤ Applications

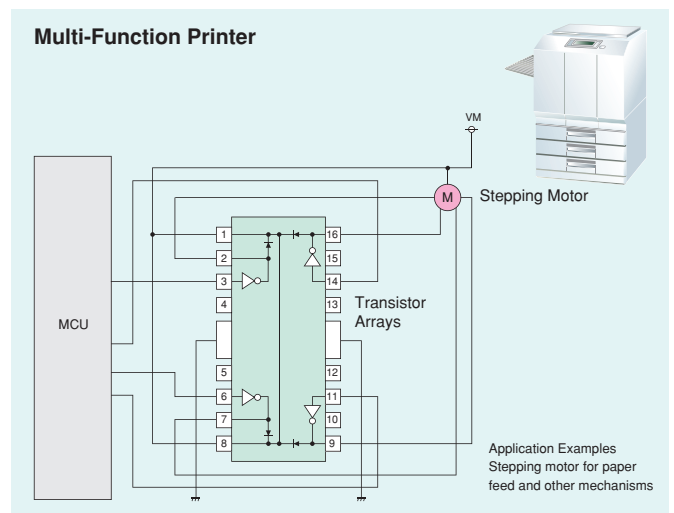
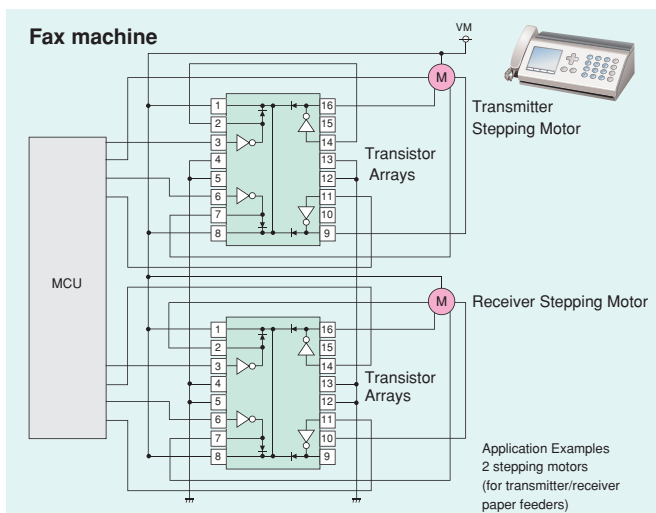
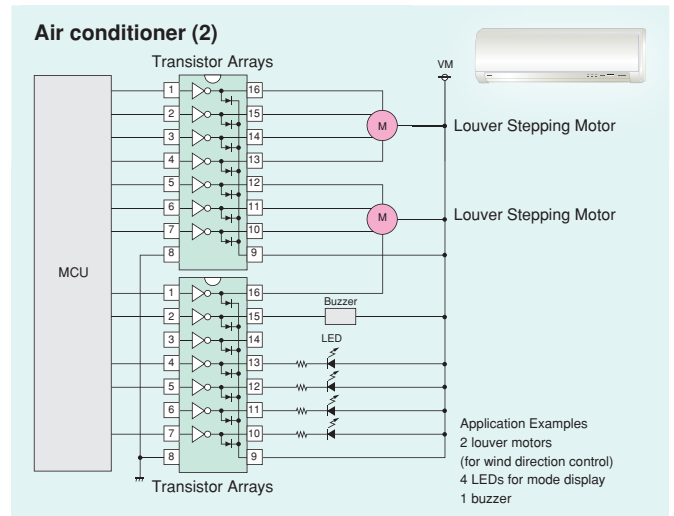
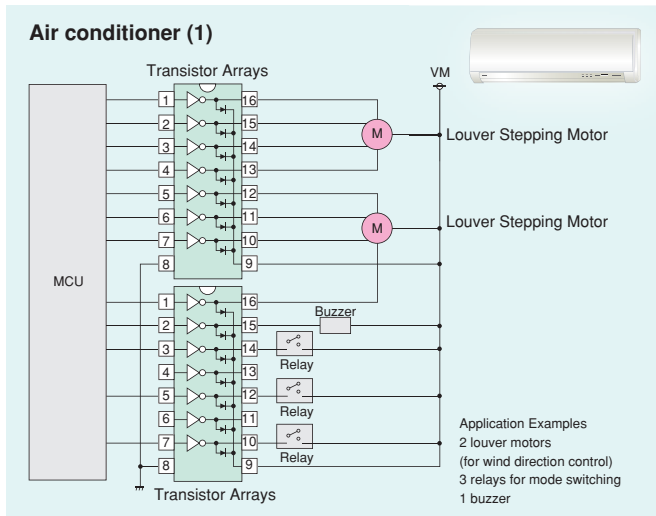

Microcontrollers

Microcontrollers Designed for Motor Applications

Toshiba offers PMD microcontrollers that contain programmable motor driver (PMD) specifically designed for inverter control of three-phase motors, reducing the CPU workload for motor control. There are two kinds of PMD microcontrollers: those with an ARM Cortex-M3 core that features an integrated vector engine and those with an 8-bit TLCS-870/X or TLCS-870/C1 core that provides 180° commutation via interrupts raised every 60° electrical of rotation.

Roadmap

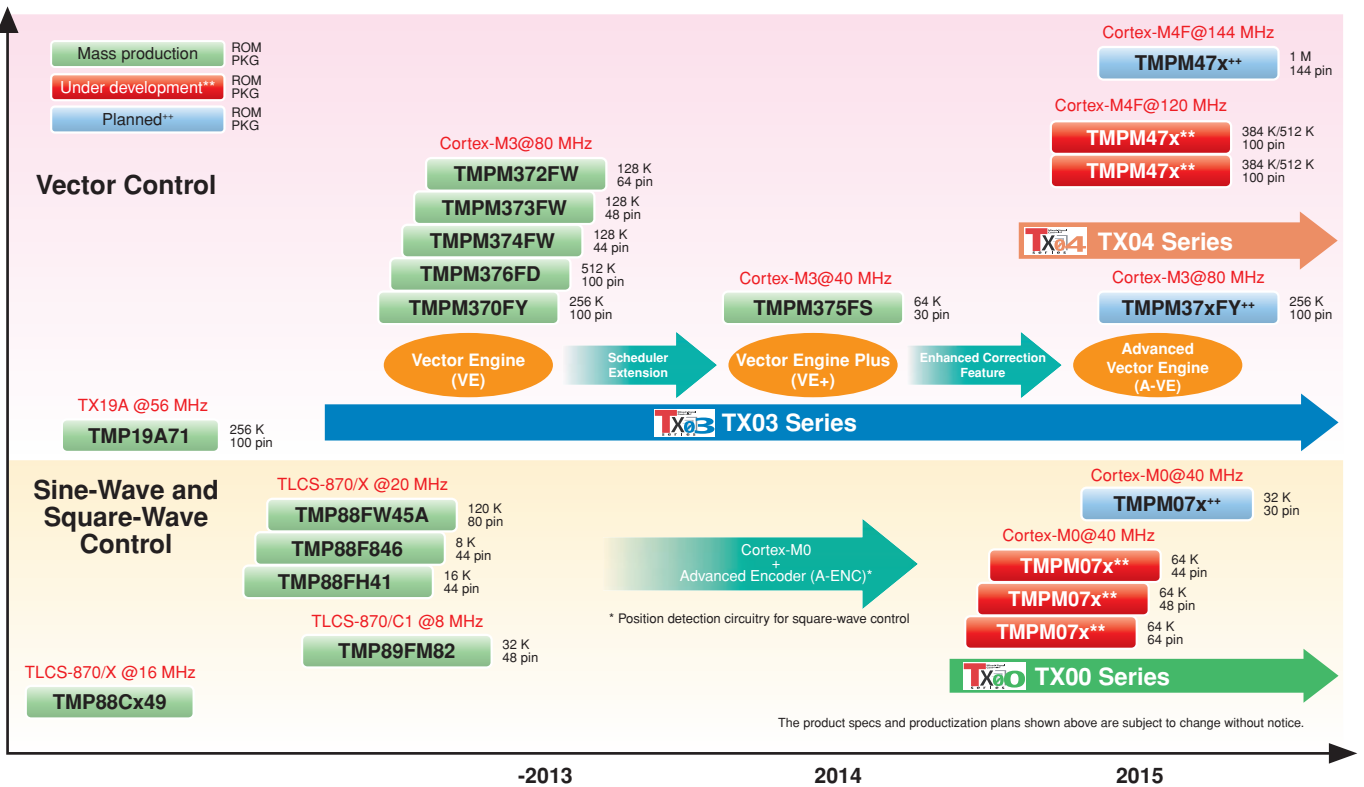

Vector Engine (VE)

The vector engine is a dedicated hardware unit that automatically performs basic vector control operations (such as coordinate transformations, phase transformations and sine/cosine calculations) and a PI algorithm for current control.

Block Diagram of a Motor Control System (Example)

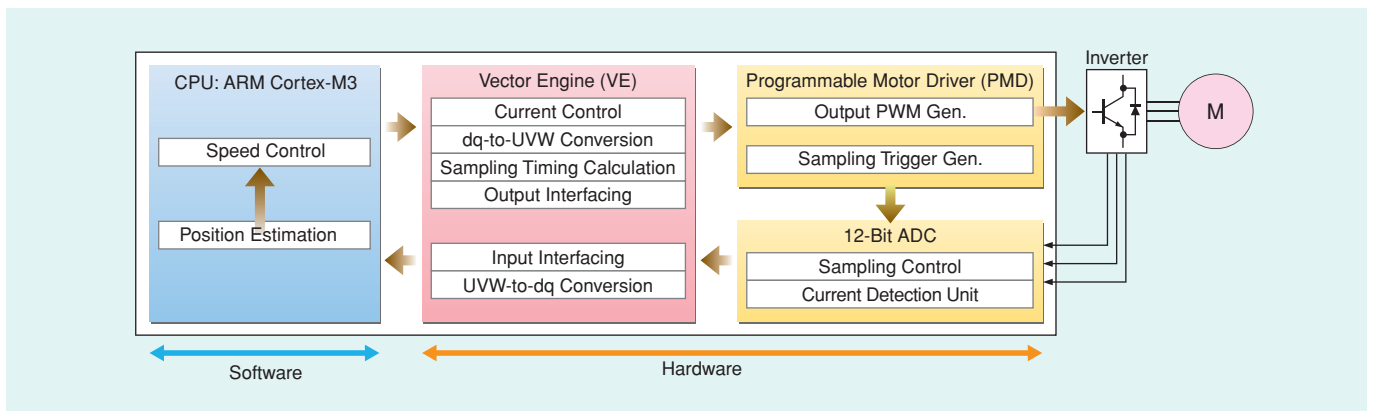

The vector engine is a computation unit designed to perform various operations for motor vector control. It executes 1) routine operations, 2) peripheral interface operations, and 3) a scheduler that controls the sequence of these operations. Since the vector engine has the capability for performing basic vector control operations (such as coordinate transformations, phase transformations and sine/cosine calculations); a PI algorithm for current control; and PMD and high-speed ADC interface operations, it helps to reduce the software workload significantly. On the other hand, speed control and position estimation operations greatly depend on system configurations and the control methods used; thus, these operations can be freely implemented as software.

Microcontroller with Vector Engine (M370 Group)

Features

- Toshiba's original Vector Engine (VE)
 - High-speed processing using dedicated hardware
 - Completes servo computation routine in 5.0 μ s
- Supports a commonly used single 5-V power supply
 - Allows the reuse of the conventional platform

Specification Overview

- High-performance ARM Cortex-M3 core with a clock rate of up to 80 MHz
- Vector Engine (VE)
- On-chip analog circuits (comparator, op-amp, encoder input)
- Available in various packages (SSOP30, LQFP44, LQFP48, LQFP64, LQFP100, QFP100)

TMPM375FSDMG with Vector Engine Plus

- High-performance Cortex-M3 core with low power consumption
- Motor control circuits (PMD, VE, ADC)
- Small package: SSOP30

Cortex-M3 Core

- Operating voltage: 4.5 V to 5.5 V
- Maximum operating frequency: 40 MHz
- Operating temperature: -40°C to 105°C
- On-chip ROM: 64 KB
- On-chip RAM: 4 KB
- Debug units: SWD/SWW
- On-chip high-speed oscillator

Peripheral Units

- Programmable motor driver (PMD): 1 unit
- Vector Engine Plus (VE+): 1 unit
- 12-bit AD converter: 1 unit (with a conversion time of 2.0 μ s)
- Op-amp (AMP): 1 channel
- SIO/UART: 2 channels
- Power-on reset (POR)
- Low-voltage detection (LVD) circuit
- Oscillation frequency detector (OFD)
- 16-bit timer: 4 channels
- I²C/SIO: 1 channel

Product Lineup

Part Number	Maximum Operating Frequency (MHz)	ROM (KB)	Motor Controller (ch)	12-Bit AD Converter (Conversion Time)	Encoder Input Logic (ch)	I/O Ports (ch)	Package
TMPM370FYDFG	80	Flash 256	2	22 (2 μ s)	2	76	QFP100
TMPM370FYFG	80	Flash 256	2	22 (2 μ s)	2	76	LQFP100
TMPM372FWUG	80	Flash 128	1	11 (2 μ s)	1	53	LQFP64
TMPM373FWDUG	80	Flash 128	1	7 (2 μ s)	1	37	LQFP48
TMPM374FWUG	80	Flash 128	1	6 (2 μ s)	1	33	LQFP44
TMPM376FDDFG	80	Flash 512	2	22 (2 μ s)	2	82	QFP100
TMPM376FDFG	80	Flash 512	2	22 (2 μ s)	2	82	LQFP100
TMPM375FSDMG	40	Flash 64	1	4 (2 μ s)	1	21	SSOP30

Application Examples



Evaluation Kit (included with a motor)

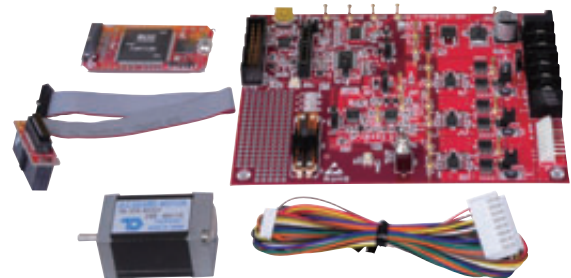

IAR System AB

Microcontrollers with PSC (M340/M440 Group)

Features

- Incorporates a Programmable Servo/Sequence Controller (PSC) that acts as a sub-processor to an Cortex-M3/M4 core-based MCU
 - Runs computational tasks in parallel at high speed
 - Reduces overall power consumption by offloading the CPU from motor servo routines and sequencing operations

Specification Overview

- High-performance Cortex-M3 core with a clock rate of up to 54 MHz (M340 Group)
Cortex-M4F core with a clock rate of up to 100 MHz (M440 Group)
- High-resolution PPG (programmable phase difference of up to $\pm 90^\circ$)
- High-speed 12-bit AD converter and 10-bit DA converters
- Housed in a small fine-pitch BGA packages

TMPM440FEXBG/F10XBG with High-Speed NANO-FLASH™-100

- Cortex-M4F core with a clock rate of up to 100 MHz and zero-wait flash access
- Low power consumption due to parallel operation of FPU and PSC
- Various analog functions
(Three 12-bit AD converters, two 10-bit DA converters)

Cortex-M4F Core

- Operating voltage: 2.7 to 3.6 V (regulated by the on-chip DC-DC converter)
- Maximum operating frequency: 100 MHz
- On-chip ROM: 1024 KB/768 KB
- On-chip RAM: 80 KB
- Debug units: JTAG/SWD/SWV, Trace4 bit

Peripheral Units

- One PSC unit with 16-KB SRAM
- External bus interface
- 12-bit AD converter
- 10-bit DA converter
- 32-bit and 16-bit timers
- PPG, HS PPG, 2-phase input pulse counter
- Real-time clock (RTC), timebase timer (TBT), watchdog timer (WDT)
- Serial interfaces: SIO/UART, Enhanced SIO (ESIO), I²C
- Key scan matrix: 8 inputs and 8 outputs

Product Lineup

Part Number	Maximum Operating Frequency (MHz)	ROM (KB)	SRAM (KB)	PSC (ch)	PPG (ch)	PHC (ch)	I/O Ports (ch)	Package
TMPM342FYXBG	40	256	36	1	8	2	63	VFPGA142
TMPM343FDXBG	50	512	80	4	8	3	59	VFPGA162
TMPM343FEXBG **		768	96					
TMPM343F10XBG **		1024						
TMPM440FEXBG	100	768	80	1	4	PHC: 2 EPH: 1	228	VFPGA289
TMPM440F10XBG		1024						

** : Under development

Application Examples



Evaluation Kit

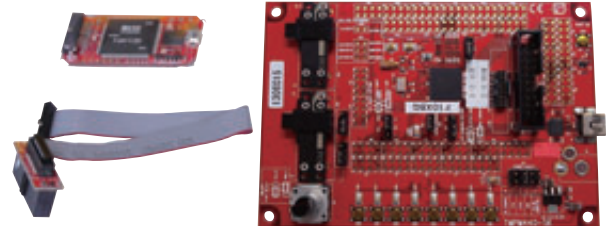

IAR System AB

Motor Drivers (Intelligent Power Devices)

Toshiba offers 250-V and 500-V motor drivers fabricated using its unique high-voltage Silicon-On-Insulator (SOI) IC process.

Intelligent Power Devices (IPDs): High-Voltage PWM Brushless Motor Drivers

Previously, a variable-voltage switching power supply and other circuits were necessary to drive a BLDC motor. Now, intelligent power devices (IPDs) fabricated using a high-voltage IC process allow the use of mains power to drive a BLDC motor without requiring a step-down voltage converter.

Toshiba's IPDs are housed in the small, thin DIP26 package that provides isolation between control and high-voltage pins to simplify board layout.

Features

- High withstand voltage due to the use of the SOI process and trench isolation structure
- Available with ratings from 250 V/1.0 A to 500 V/3.0 A
- Internal bootstrap power supply for the high-side gate drives

DIP26 Package

- Package body thickness: 3.8 mm max
- 16 control pins and 10 high-voltage pins are isolated on the opposite sides of the package.
(The complete isolation of these pins simplifies board trace routing.)
- Improved thermal resistance

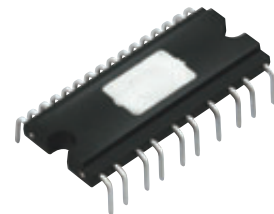

DIP26

TPD4151K/TPD4142K Block Diagram

- Variable-speed brushless motor drive via the Hall sensor or Hall IC inputs

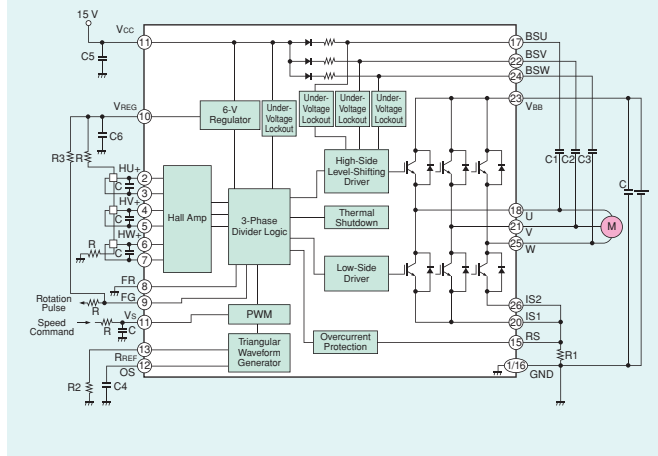

TPD4123K/TPD4144K/TPD4135K Block Diagram

- Sine-wave drive in combination with a controller
- The TPD4123K, TPD4134K and TPD4135K are pin-compatible and interchangeable according to the motor ratings.

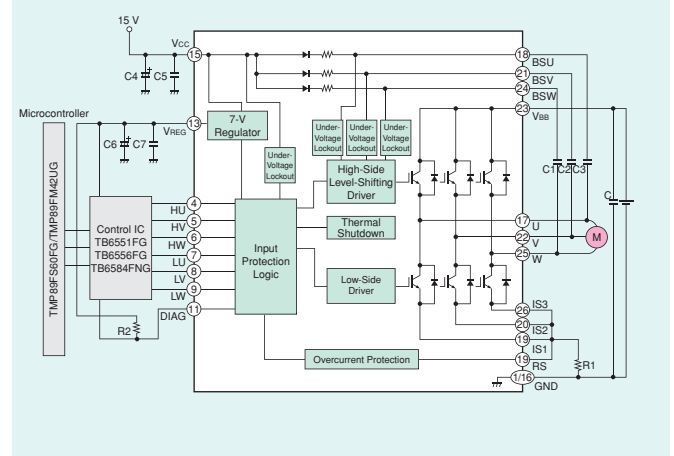

Product Lineup

Part Number	Ratings	Features						
		Hall Sensor/ Hall IC Inputs	6 Inputs	Three-Phase Distribution PWM Circuit	Level Shifter	Overcurrent Protection	Thermal Shutdown	Undervoltage Protection
TPD4151K	250 V/1.0 A	✓		✓	✓	✓	✓	✓
TPD4142K	500 V/1.0 A	✓		✓	✓	✓	✓	✓
TPD4123K	500 V/1.0 A		✓		✓	✓	✓	✓
TPD4123AK	500 V/1.0 A		✓		✓	✓	✓	✓
TPD4144K	500 V/2.0 A		✓		✓	✓	✓	✓
TPD4144AK	500 V/2.0 A		✓		✓	✓	✓	✓
TPD4135K	500 V/3.0 A		✓		✓	✓	✓	✓
TPD4135AK	500 V/3.0 A		✓		✓	✓	✓	✓

Photocouplers

Next-Generation IGBT/MOSFET-Drive Photocouplers

Toshiba offers IGBT/MOSFET-drive photocouplers fabricated using the latest 0.13- μm BiCD process. Overcurrent protection, rail-to-rail output and a thin package with a thickness of 2.3 mm help improve the efficiency and reduce the size of system applications.

IGBT/MOSFET-Drive Photocoupler with Overcurrent Protection (TLP5214)

The TLP5214 monitors the saturation voltage, $V_{CE(sat)}$, of an IGBT and shuts down its output when $V_{CE(sat)}$ exceeds 6.5 V typical in the event of an overcurrent condition.

Additionally, the TLP5214 is housed in the thin SO16L package and provides active mirror clamping, rail-to-rail output and other features, reducing the number of external components compared with that previously required. This helps reduce bill-of-material (BOM) costs and board size. Despite the low-profile package, the TLP5214 provides a clearance distance of 8 mm and guarantees an isolation voltage of up to 5 kVrms, making it suitable for applications requiring higher insulation performance.

- $V_{CE(sat)}$ detection and shutdown protect an IGBT/MOSFET in the event of overcurrent.
- The FAULT signal is fed back to the controller at high speed.
- Active mirror clamping prevents IGBT/MOSFET failures due to mirror current.
- A rail-to-rail output reduces power loss.
- Maximum output peak current: 4.0 A
- Propagation delay (t_{pHL} / t_{pLH}): 150 ns max



SO16L

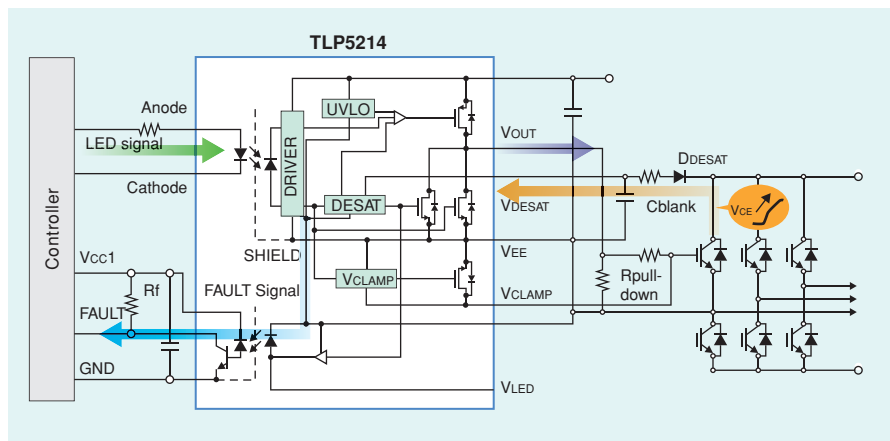

Soft Shutdown Waveform Example

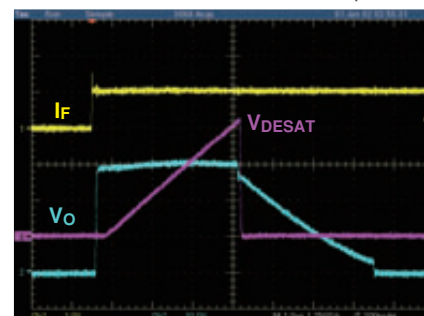

Conditions:
 $I_F = 10 \text{ mA}$, $V_{CC} = 30 \text{ V}$, $R_G = 10 \Omega$, $C_G = 25 \text{ nF}$, $T_a = 25^\circ\text{C}$
 I_F : 10 mA/div, V_o : 10 V/div, V_{DESAT} : 2 V/div, 1 $\mu\text{s/div}$

Rail-to-Rail Output Photocoupler for IGBT/MOSFET Drive (TLP575x Series)

Generally, the high-level output voltage (V_{OH}) of an IGBT-drive photocoupler is a few volts lower than the power supply voltage. In contrast, the TLP575x Series in the thin SO6L package provides a full-swing (i.e., rail-to-rail) output from ground to almost the supply voltage. The rail-to-rail output helps reduce the power loss of both the photocoupler and the IGBT during switching. Despite the low-profile package, the TLP575x Series provides a clearance distance of 8 mm and guarantees an isolation voltage of up to 5 kVrms, making it suitable for applications requiring higher insulation performance.

- A rail-to-rail output reduces power loss.
- Maximum output peak current: 1.0 A to 4.0 A
- Propagation delay (t_{pHL} / t_{pLH}): 150 ns max
- Propagation delay skew (t_{psk}): ± 80 ns

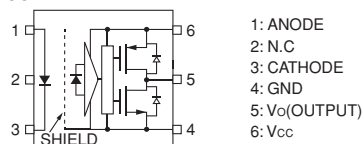

SO6L

Part Number	TLP5751	TLP5752	TLP5754
Peak current (A)	1.0	2.5	4.0
V_{OH} (V)		$V_{CC} - 0.3$	
V_{OL} (V)		0.2	
Operating temperature range ($^\circ\text{C}$)		-40 to 110	
t_{pHL}/t_{pLH} (ns)		150	
t_{psk} (ns)		± 80	
V_{CC} (V)		15 to 30	
BVs (Vrms)		5000	

Benefits of the Thin SO6L Package with a Thickness of 2.3 mm

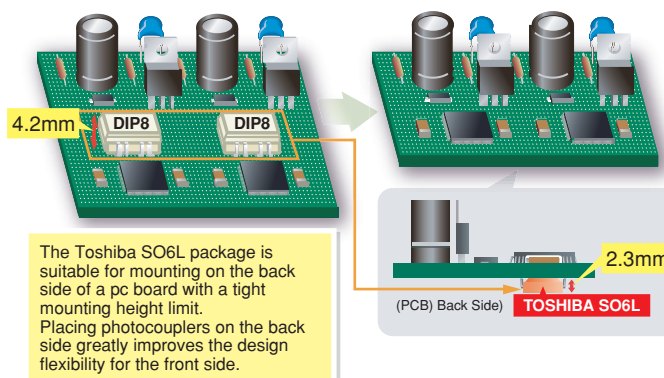

Toshiba America**Electronic Components, Inc.**

- Irvine, Headquarters
Tel: (949)462-7700 Fax: (949)462-2200
- Buffalo Grove (Chicago)
Tel: (847)484-2400 Fax: (847)541-7287
- Duluth/Atlanta
Tel: (770)931-3363 Fax: (770)931-7602
- El Paso
Tel: (915)533-4242
- Marlborough
Tel: (508)481-0034 Fax: (508)481-8828
- Parsippany
Tel: (973)541-4715 Fax: (973)541-4716
- San Jose
Tel: (408)526-2400 Fax: (408)526-2410
- Wixom (Detroit)
Tel: (248)347-2607 Fax: (248)347-2602

Toshiba Electronics do Brasil Ltda.

- Tel: (011)2936-6681 Fax: (011)2936-6675

Toshiba India Private Ltd.

- New Delhi Office
Tel: (0124)499-6600 Fax: (0124)499-6611
- Bangalore Office
Tel: (080)251-90800 Fax: (080)490-91945

Toshiba Electronics Europe GmbH

- Düsseldorf Head Office
Tel: (0211)5296-0 Fax: (0211)5296-400
- France Branch
Tel: (1)47282181
- Italy Branch
Tel: (039)68701 Fax: (039)6870205
- Munich Office
Tel: (089)20302030 Fax: (089)203020310
- Spain Branch
Tel: (91)660-6798 Fax: (91)660-6799
- Sweden Branch
Tel: (08)704-0900 Fax: (08)80-8459
- U.K. Branch
Tel: (1932)841600

Toshiba Vietnam Consumer Products Co.,Ltd.

- Tel: (043)776-5950 Fax: (043)776-5956

Toshiba Electronics Asia (Singapore) Pte. Ltd.

- Tel: (6278)5252 Fax: (6271)5155

Toshiba Electronics Service (Thailand) Co., Ltd.

- Tel: (02)835-3491 Fax: (02)835-3490

Toshiba Electronics Trading (Malaysia)Sdn. Bhd.

- Kuala Lumpur Head Office
Tel: (03)5631-6311 Fax: (03)5631-6307
- Penang Office
Tel: (04)226-8523 Fax: (04)226-8515

Toshiba Electronics (China) Co., Ltd.

- Shanghai Head Office
Tel: (021)6139-3888 Fax: (021)6190-8288
- Beijing Branch
Tel: (010)6590-8796 Fax: (010)6590-8791
- Chengdu Branch
Tel: (028)8675-1773 Fax: (028)8675-1065
- Hangzhou Office
Tel: (0571)8717-5004 Fax: (0571)8717-5013
- Nanjing Office
Tel: (025)8689-0070 Fax: (025)8689-0125
- Qingdao Branch
Tel: (532)8579-3328 Fax: (532)8579-3329
- Shenzhen Branch
Tel: (0755)3686-0880 Fax: (0755)3686-0816
- Dalian Branch
Tel: (0411)8368-6882 Fax: (0411)8369-0822
- Xiamen Branch
Tel: (2375)226-1398 Fax: (0592)226-1399
- Dongguan Branch
Tel: (0769)8155-6858 Fax: (0769)8155-6368
- Toshiba Electronics Asia, Ltd.
Tel: 2375-6111 Fax: 2375-0969
- Toshiba Electronics Korea Corporation
Tel: (02)3484-4334 Fax: (02)3484-4302
- Toshiba Electronics Taiwan Corporation
Tel: (02)2508-9988 Fax: (02)2508-9999

RESTRICTIONS ON PRODUCT USE

- ▶ Toshiba Corporation, and its subsidiaries and affiliates (collectively "TOSHIBA"), reserve the right to make changes to the information in this document, and related hardware, software and systems (collectively "Product") without notice.
- ▶ This document and any information herein may not be reproduced without prior written permission from TOSHIBA. Even with TOSHIBA's written permission, reproduction is permissible only if reproduction is without alteration/omission.
- ▶ Though TOSHIBA works continually to improve Product's quality and reliability, Product can malfunction or fail. Customers are responsible for complying with safety standards and for providing adequate designs and safeguards for their hardware, software and systems which minimize risk and avoid situations in which a malfunction or failure of Product could cause loss of human life, bodily injury or damage to property, including data loss or corruption. Before customers use the Product, create designs including the Product, or incorporate the Product into their own applications, customers must also refer to and comply with (a) the latest versions of all relevant TOSHIBA information, including without limitation, this document, the specifications, the data sheets and application notes for Product and the precautions and conditions set forth in the "TOSHIBA Semiconductor Reliability Handbook" and (b) the instructions for the application with which the Product will be used with or for. Customers are solely responsible for all aspects of their own product design or applications, including but not limited to (a) determining the appropriateness of the use of this Product in such design or applications; (b) evaluating and determining the applicability of any information contained in this document, or in charts, diagrams, programs, algorithms, sample application circuits, or any other referenced documents; and (c) validating all operating parameters for such designs and applications. **TOSHIBA ASSUMES NO LIABILITY FOR CUSTOMERS' PRODUCT DESIGN OR APPLICATIONS.**
- ▶ **PRODUCT IS NEITHER INTENDED NOR WARRANTED FOR USE IN EQUIPMENTS OR SYSTEMS THAT REQUIRE EXTRAORDINARILY HIGH LEVELS OF QUALITY AND/OR RELIABILITY, AND/OR A MALFUNCTION OR FAILURE OF WHICH MAY CAUSE LOSS OF HUMAN LIFE, BODILY INJURY, SERIOUS PROPERTY DAMAGE AND/OR SERIOUS PUBLIC IMPACT ("UNINTENDED USE").** Except for specific applications as expressly stated in this document, Unintended Use includes, without limitation, equipment used in nuclear facilities, equipment used in the aerospace industry, medical equipment, equipment used for automobiles, trains, ships and other transportation, traffic signaling equipment, equipment used to control combustions or explosions, safety devices, elevators and escalators, devices related to electric power, and equipment used in finance-related fields. **IF YOU USE PRODUCT FOR UNINTENDED USE, TOSHIBA ASSUMES NO LIABILITY FOR PRODUCT.** For details, please contact your TOSHIBA sales representative.
- ▶ Do not disassemble, analyze, reverse-engineer, alter, modify, translate or copy Product, whether in whole or in part.
- ▶ Product shall not be used for or incorporated into any products or systems whose manufacture, use, or sale is prohibited under any applicable laws or regulations.
- ▶ The information contained herein is presented only as guidance for Product use. No responsibility is assumed by TOSHIBA for any infringement of patents or any other intellectual property rights of third parties that may result from the use of Product. No license to any intellectual property right is granted by this document, whether express or implied, by estoppel or otherwise.
- ▶ **ABSENT A WRITTEN SIGNED AGREEMENT, EXCEPT AS PROVIDED IN THE RELEVANT TERMS AND CONDITIONS OF SALE FOR PRODUCT, AND TO THE MAXIMUM EXTENT ALLOWABLE BY LAW, TOSHIBA (1) ASSUMES NO LIABILITY WHATSOEVER, INCLUDING WITHOUT LIMITATION, INDIRECT, CONSEQUENTIAL, SPECIAL, OR INCIDENTAL DAMAGES OR LOSS, INCLUDING WITHOUT LIMITATION, LOSS OF PROFITS, LOSS OF OPPORTUNITIES, BUSINESS INTERRUPTION AND LOSS OF DATA, AND (2) DISCLAIMS ANY AND ALL EXPRESS OR IMPLIED WARRANTIES AND CONDITIONS RELATED TO SALE, USE OF PRODUCT, OR INFORMATION, INCLUDING WARRANTIES OR CONDITIONS OF MERCHANTABILITY, FITNESS FOR A PARTICULAR PURPOSE, ACCURACY OF INFORMATION, OR NONINFRINGEMENT.**
- ▶ Product may include products using GaAs (Gallium Arsenide). GaAs is harmful to humans if consumed or absorbed, whether in the form of dust or vapor. Handle with care and do not break, cut, crush, grind, dissolve chemically or otherwise expose GaAs in Product.
- ▶ Do not use or otherwise make available Product or related software or technology for any military purposes, including without limitation, for the design, development, use, stockpiling or manufacturing of nuclear, chemical, or biological weapons or missile technology products (mass destruction weapons). Product and related software and technology may be controlled under the applicable export laws and regulations including, without limitation, the Japanese Foreign Exchange and Foreign Trade Law and the U.S. Export Administration Regulations. Export and re-export of Product or related software or technology are strictly prohibited except in compliance with all applicable export laws and regulations.
- ▶ Please contact your TOSHIBA sales representative for details as to environmental matters such as the RoHS compatibility of Product. Please use Product in compliance with all applicable laws and regulations that regulate the inclusion or use of controlled substances, including without limitation, the EU RoHS Directive. **TOSHIBA ASSUMES NO LIABILITY FOR DAMAGES OR LOSSES OCCURRING AS A RESULT OF NONCOMPLIANCE WITH APPLICABLE LAWS AND REGULATIONS.**

TOSHIBA**TOSHIBA CORPORATION**

Semiconductor & Storage Products Company

Website: <http://toshiba.semicon-storage.com/>



Компания «ЭлектроПласт» предлагает заключение долгосрочных отношений при поставках импортных электронных компонентов на взаимовыгодных условиях!

Наши преимущества:

- Оперативные поставки широкого спектра электронных компонентов отечественного и импортного производства напрямую от производителей и с крупнейших мировых складов;
- Поставка более 17-ти миллионов наименований электронных компонентов;
- Поставка сложных, дефицитных, либо снятых с производства позиций;
- Оперативные сроки поставки под заказ (от 5 рабочих дней);
- Экспресс доставка в любую точку России;
- Техническая поддержка проекта, помощь в подборе аналогов, поставка прототипов;
- Система менеджмента качества сертифицирована по Международному стандарту ISO 9001;
- Лицензия ФСБ на осуществление работ с использованием сведений, составляющих государственную тайну;
- Поставка специализированных компонентов (Xilinx, Altera, Analog Devices, Intersil, Interpoint, Microsemi, Aeroflex, Peregrine, Syfer, Eurofarad, Texas Instrument, Miteq, Cobham, E2V, MA-COM, Hittite, Mini-Circuits, General Dynamics и др.);

Помимо этого, одним из направлений компании «ЭлектроПласт» является направление «Источники питания». Мы предлагаем Вам помощь Конструкторского отдела:

- Подбор оптимального решения, техническое обоснование при выборе компонента;
- Подбор аналогов;
- Консультации по применению компонента;
- Поставка образцов и прототипов;
- Техническая поддержка проекта;
- Защита от снятия компонента с производства.



Как с нами связаться

Телефон: 8 (812) 309 58 32 (многоканальный)

Факс: 8 (812) 320-02-42

Электронная почта: org@eplast1.ru

Адрес: 198099, г. Санкт-Петербург, ул. Калинина, дом 2, корпус 4, литера А.