

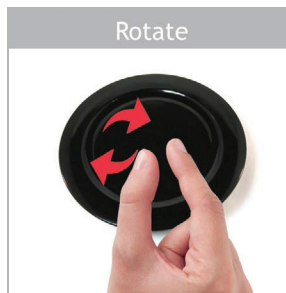

Let Your Fingers Do The Directing

Grayhill's Instinct technology tracks up to five finger touches at a time. The Multi-Touch Control Wheel combines a multi-touch touchpad with a circular groove to offer even more functionality. Touching the North, South, East or West points in the groove can be interpreted as joystick switch inputs. Running your finger around the groove can be interpreted as an encoder input. The number of relative state changes is user configurable from 4 to 256 per revolution. A proximity sensor automatically detects when a user approaches the device, allowing the OEM equipment to enter a power-saving mode when not in use. A few of the many multi-touch gestures are shown below.



Multi-Touch Control Wheel

Features

- Grayhill Instinct™ Gesture Recognition
- Three devices in one:
 - Multi-Touch touchpad
 - 4-256 position rotary encoder
 - 4 position (N, S, E, W) joystick
- Proximity sensor
- Impervious to cleaning solutions
- Easy to integrate into any device
- Rugged, scratch-resistant surface
- USB compatible HID device

Possible applications include:

- Medical devices
- Clean room controls
- Off-Highway vehicles

Instinct™ Technology. Intuitively Functional.

Grayhill Instinct is a set of multi-touch gesture recognition software tools that, when integrated with Grayhill multi-touch components, creates more intuitive human interface solutions.

A Shorter Distance from Mind to Machine

An intuitive, easy-to-use interface improves productivity. Instinctive movements provide a variety of commands, all without the fingers leaving the touchpad. This allows faster interaction without needing to take eyes off of the screen. Plus, ergonomics are improved by consolidating all controls within easy reach.

Simplicity in use & Device Design

The Multi-Touch Control Wheel can replace touchscreens, keypads, trackballs, switches and joysticks. This makes for clean design and cuts costs of manufacturing. The MTCW increases the engineer's flexibility in building functionality into any product, while reducing front panel size and complexity.

DIMENSIONS

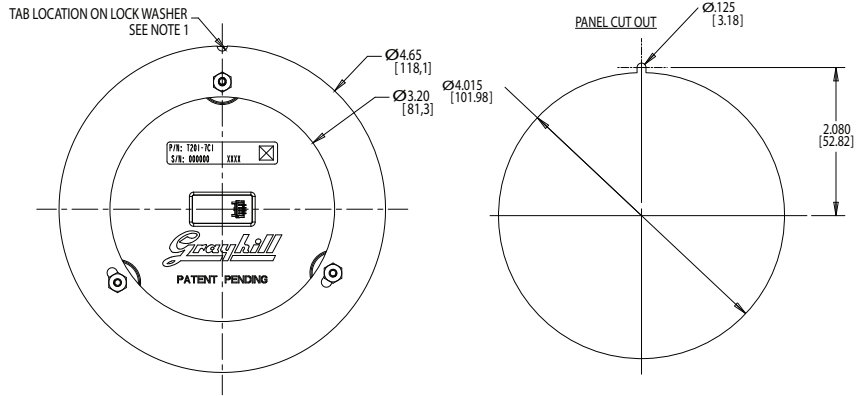
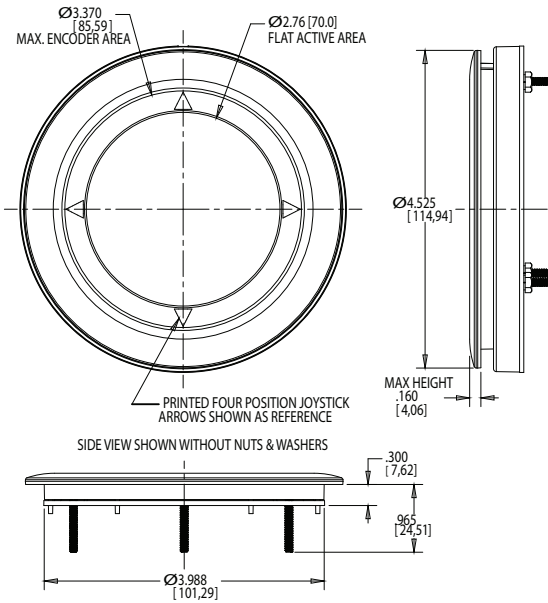

NOTES:
1. TAB DENOTES TOUCH SCREEN "TOP" OR "NORTH"

ENVIRONMENTAL & MATERIAL SPECIFICATIONS

Operating temperature	-10°C to +60°C
Seal	IP67
Humidity	95% Humidity at 60°C for 240 hours
Chemical resistance (Resistance to accidental spills and disinfectants)	72 Hr exposure to Coffee, Cola, Saline, Methylated spirits, Isopropyl, Ammonia, Chlorine bleach, Sodium Hypochlorite, Ethanol, Dupont® Virkon®, Dupont® RelyOn®, Betadine, Hydrogen Peroxide, Cidex®, Steris®, Civco®
Material	Xenoy

ELECTRICAL PERFORMANCE SPECIFICATIONS

USB	2.0, 3.0 Compatible, Full speed HID Compliant
Operating Voltage	2.5 to 5.5 Vdc
Input Current	50mA max @5V
Icon Wear Resistance	Minimum 1,000,000 cycle
Touchpad Resolution	1280 x 1280 pixels

CONNECTION

Mating Connector: Molex 501939-0400

PIN	1	2	3	4
USB	+ Vcc	USB Negative (D-)	USB Positive (D+)	Gnd

Grayhill, Inc.

561 Hillgrove Avenue phone: (708) 354-1040
LaGrange, Illinois 60525 fax: (708) 354-2820 instinct@grayhill.com

ELECTROMAGNETIC COMPATIBILITY SPECIFICATIONS

Designed and tested for use in systems requiring IEC 60601-1

RF Emissions	CISPR 11 Group 1 Class B
Electrostatic Discharge	IEC 61000-4-2 ±6kV Contact ±8kV Air
Electrical Fast Transient/Burst	IEC 61000-4-4 ±1kV Coupling Clamp
Power Frequency (50/60 Hz) Magnetic Field	IEC 61000-4-8 3 A/m
Conducted RF*	IEC 61000-4-6 Level 1 - 120dBuV, 150 kHz to 80 MHz
Radiated RF	IEC 61000-4-3 3 V/M 80 MHz to 2.5 GHz

* see Grayhill application notes

Specifications subject to change

SOFTWARE DEVELOPMENT KIT part: T201-DEV1

Grayhill offers an Instinct Software Development Kit that provides the user with a common development platform for prototyping and evaluating different solutions. The Software Development Kit is comprised of a mounted Multi-Touch Control Wheel, a standard USB cable and demo software. The kit is available directly from Grayhill, or from one of several distributors. For more detailed information, including a copy of the User's Guide, go to www.grayhill.com/instinct.

ORDERING INFORMATION

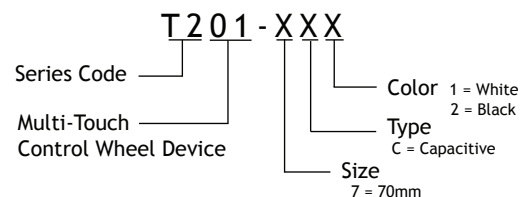

Contact Grayhill for Custom Options.



Компания «ЭлектроПласт» предлагает заключение долгосрочных отношений при поставках импортных электронных компонентов на взаимовыгодных условиях!

Наши преимущества:

- Оперативные поставки широкого спектра электронных компонентов отечественного и импортного производства напрямую от производителей и с крупнейших мировых складов;
- Поставка более 17-ти миллионов наименований электронных компонентов;
- Поставка сложных, дефицитных, либо снятых с производства позиций;
- Оперативные сроки поставки под заказ (от 5 рабочих дней);
- Экспресс доставка в любую точку России;
- Техническая поддержка проекта, помощь в подборе аналогов, поставка прототипов;
- Система менеджмента качества сертифицирована по Международному стандарту ISO 9001;
- Лицензия ФСБ на осуществление работ с использованием сведений, составляющих государственную тайну;
- Поставка специализированных компонентов (Xilinx, Altera, Analog Devices, Intersil, Interpoint, Microsemi, Aeroflex, Peregrine, Syfer, Eurofarad, Texas Instrument, Miteq, Cobham, E2V, MA-COM, Hittite, Mini-Circuits, General Dynamics и др.);

Помимо этого, одним из направлений компании «ЭлектроПласт» является направление «Источники питания». Мы предлагаем Вам помощь Конструкторского отдела:

- Подбор оптимального решения, техническое обоснование при выборе компонента;
- Подбор аналогов;
- Консультации по применению компонента;
- Поставка образцов и прототипов;
- Техническая поддержка проекта;
- Защита от снятия компонента с производства.



Как с нами связаться

Телефон: 8 (812) 309 58 32 (многоканальный)

Факс: 8 (812) 320-02-42

Электронная почта: org@eplast1.ru

Адрес: 198099, г. Санкт-Петербург, ул. Калинина, дом 2, корпус 4, литера А.