

### PRODUCT OVERVIEW

D1U54P-W-2000-12-HxxC is a series of 2000W highly efficient power factor corrected front end power supplies with a 12Vdc (main), a standby output, and is capable of active current sharing. A multifunctional status LED, hardware logic signals and PMBus™ digital communications are standard features and supports cold redundant system applications. The low profile 1U, 46W/cubic inch package make this series ideal for delivering reliable, efficient power to servers, workstations, storage systems and other 12V distributed power architectures.

### ORDERING GUIDE

Part Number	Output power & Nominal Input Voltage					Main Output	Standby Output	Airflow	
	230-240 Vac	220 Vac	208 Vac	200 Vac	110-120 Vac				
D1U54P-W-2000-12-HA3C	2000W	1956W	1848W	1776W	1400W	1260W	12Vdc	5Vdc	F - B B - F
D1U54P-W-2000-12-HA4C								3.3Vdc	F - B B - F
D1U54P-W-2000-12-HB3C									F - B B - F
D1U54P-W-2000-12-HB4C									F - B B - F
D1U54P-W-2000-12-HC3C									F - B B - F
D1U54P-W-2000-12-HC4C								F - B B - F	

### INPUT CHARACTERISTICS

Parameter	Conditions	Min.	Nom.	Max.	Units
Input Source Voltage AC Operating Range <sup>1</sup>		90	100/110/240	264	Vac
Input Source Voltage DC Operating Range <sup>1, 2</sup>			240		Vdc
Input Source Frequency		47	50/60	63	Hz
Turn-on Input Voltage	Ramp up	74		84	Vac
Turn-off Input Voltage	Ramp down	70		80	Vac
Maximum current at Vin = 180Vac/60Hz				15	Arms
Inrush Current	Cold start between 0 to 200msec, 264Vac			35	Apk
Power Factor	At 230Vac, full load		0.99		
Efficiency (230Vac), excluding fan load	20% load	90			
HxxC models 80 Plus® Certified	50% load	94			%
	100% load	91			

<sup>1</sup> Insert power supply into mating connector prior to applying input voltage; <sup>2</sup> Only for China

### OUTPUT VOLTAGE CHARACTERISTICS

Output	Parameter	Conditions	Min.	Typ.	Max.	Units	
12V	Nominal Output Voltage			12		Vdc	
	Output Set Point Accuracy	50% load; Tamb =25°C	-0.5		+0.5		
	Line and Load Regulation <sup>2</sup>	Measured at remote sense	-1.0		+1.5	%	
	Ripple Voltage & Noise <sup>1,2</sup>	20MHz Bandwidth			120	mV p-p	
	Output Current	2000W (207-264 Vac) Continuous <sup>4</sup>		0		166.7	A
		1956W (198-242 Vac) Continuous		0		163	
		1848W (188-228 Vac) Continuous		0		154	
		1776W (180-220 Vac) Continuous		0		148	
		1400W (99-132Vac) Continuous		0		116.7	
		1260W (90-110 Vac) Continuous		0		105	
Load Capacitance				30,000	µF		
12VSB	Nominal Output Voltage			12		Vdc	
	Line and Load Regulation <sup>3</sup>		11.7		12.3		
	Ripple Voltage & Noise <sup>1,3</sup>	20MHz Bandwidth			120	mV p-p	
	Output Current		0		3.0	A	
3.3VSB	Load Capacitance				1500	µF	
	Nominal Output Voltage			3.30		Vdc	
	Line and Load Regulation <sup>2</sup>		3.14		3.46	Vdc	
	Ripple Voltage & Noise <sup>1,3</sup>	20MHz Bandwidth			75	mV p-p	
5.0VSB	Output Current		0		3.0	A	
	Load Capacitance				3,000	µF	
	Nominal Output Voltage			5.0		Vdc	
	Line and Load Regulation <sup>3</sup>		4.76		5.24	Vdc	
5.0VSB	Ripple Voltage & Noise <sup>1,3</sup>	20MHz Bandwidth			75	mV p-p	
	Output Current		0		3.0	A	
	Load Capacitance				3,000	µF	

<sup>1</sup> Ripple and noise are measured with 0.1 µF of ceramic capacitance and 10 µF of tantalum capacitance on each of the power supply outputs. A short coaxial cable to the scope termination is used.

<sup>2</sup> Minimum Load of 7A applied to meet these limits. <sup>3</sup> Minimum Load of 0.25A applied to meet these limits <sup>4</sup> Peak current 200A, 100ms max.

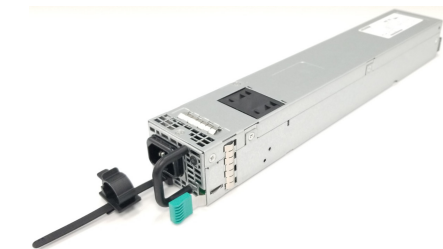

Pictorial View Only; NTS

### FEATURES

- 2000W continuous output power
- Cold Redundant power management features
- IEC60320-C16 connector for maximized low line operation
- 80+ Certified Platinum, HxxC models
- 12V main output, 120% surge current capability
- 3.3V, 5.0V & 12V Standby Output Options
- 1U height: 2.15" x 12.65" x 1.57"
- > 46 Watts per cubic inch density
- N+1 redundant, Hot Swap Capable
- Active (digital) current sharing on 12V main output; Integral ORing /isolation provided for both outputs; compatible with DC input series
- Internal cooling fan (variable speed)
- Overvoltage, overcurrent, over temperature Protection
- PMBus™/I<sup>2</sup>C interface with LED status indicators
- RoHS compliant
- Two Year Warranty

Available now at: [www.murata-ps.com/en/3d/acdc.html](http://www.murata-ps.com/en/3d/acdc.html)



Test Certificate and Test Report  
Planned Submission

**OUTPUT CHARACTERISTICS**

Parameter	Conditions	Min.	Typ.	Max.	Units
Startup Time	AC ramp up			3	s
Transient Response	12V Main 10% to 60% load step (50% max load change); 1A/ $\mu$ s slew rate; 2,000 $\mu$ F load capacitance	-5		+5	% nom
	Recovery Time to within 1% Vnom		2		ms
	VSB, 10% to 60% load step (50% max. load change); 1A/ $\mu$ s slew rate.	-5		+5	% nom
Current sharing accuracy	Recovery Time to within 1% Vnom		2		ms
	At 100% load	-5		+5	%
Hot Swap Transients	All outputs remain in regulation	-5		+5	%
Holdup Time	230-240Vac in voltage ranges, 2000W load, output dropping to 10.8V	10			ms
	230-240Vac in voltage ranges, 1000W load, output dropping to 10.8V	20			ms

**ENVIRONMENTAL CHARACTERISTICS**

Parameter	Conditions	Min.	Typ.	Max.	Units
Storage Temperature Range		-20		70	°C
Operating Temperature Range	2000W; 230-240Vac nom.	-5		50	
	1900W @ 4000M; 220Vac, 230-240Vac	-5		40	
Operating Humidity	Noncondensing	5		90	%
Storage Humidity		5		95	
Altitude (Derating at 40°C)		4000			m
Shock	30G non-operating				
Operational Vibration	Sine sweep, 5-150Hz, 2G; random vibration, 5-500Hz, 1.11G				
MTBF	Per Telcordia SR-332 M1C3 @40°C	540K			hrs.
Safety Approval Standards (Planned Submissions)	CAN/CSA-C22.2 No. 60950-1-07, Amendment 1:2011, Amendment 2:2014 (MOD) ANSI/UL 60950-1-2014 CSA: IEC 60950-1:2005 (Second Edition) + Am 1:2009 + Am 2:2013 TUV: EN 60950-1:2006+A11:2009+A1:2010+A12:2011+A2:2013 BSMI: CNS14336-1 (099/09/30); CNS13438 (095/06/01) CQC: GB4943.1-2011; GB9254-1-2008; GB17625.1-2012				
Input Fuse	Dual 20A/420VAC/420DC fuse provided as a series protective element in both input "line" and "neutral" connection				
Weight	2.56 lbs. (1.16 kg)				

**AIRFLOW CHARACTERISTICS:**

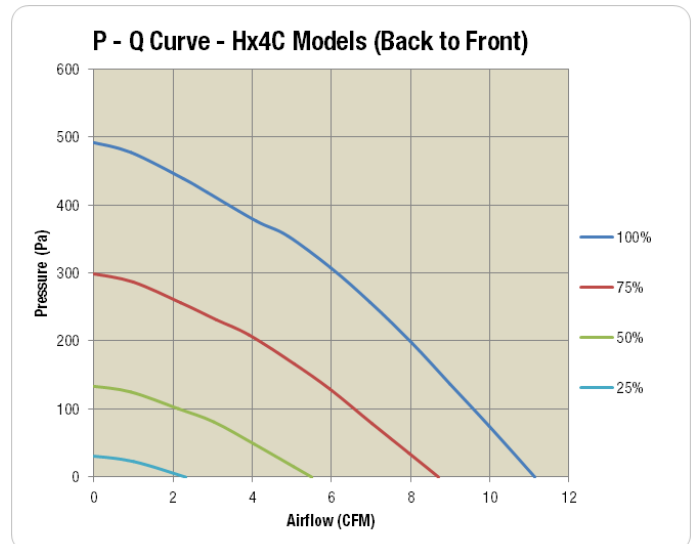
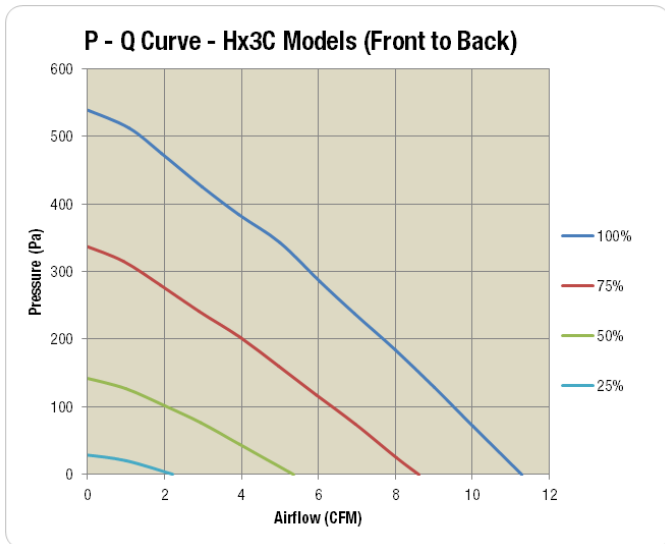

PROTECTION CHARACTERISTICS						
Output Voltage	Parameter	Conditions	Min.	Typ.	Max.	Units
12V	Over temperature (intake)	Auto restart	60	65	70	°C
	Overvoltage	Latching <sup>1</sup>	13.0		14.5	V
	Short-circuit	Latching <sup>1</sup>	200		-	
	Overcurrent (180-264Vac)	Hiccup mode, 5 retries before <sup>1</sup> Latch-off. Protection is delayed 100mS to accommodate Peak Power	184		200	A
	Overcurrent (90-150Vac)	Hiccup mode, 5 retries before <sup>1</sup> Latch-off.	110		120	A
12VSB	Overvoltage	Latching <sup>1</sup>	13.0		14.5	V
	Overcurrent	Hiccup	3.1		4.5	A
5.0VSB	Overvoltage	Latching <sup>1</sup>	5.4		6.0	V
	Overcurrent	Hiccup	3.1		5.0	A
3.3VSB	Overvoltage	Latching <sup>1</sup>	3.6		4.0	V
	Overcurrent	Hiccup	3.1		5.0	A

<sup>1</sup> Latch-off requires recycling either the AC input or PS\_ON to resume operation

ISOLATION CHARACTERISTICS					
Parameter	Conditions	Min.	Typ.	Max.	Units
Insulation Safety Rating / Test Voltage	Input to Output - Reinforced	3000			Vrms
	Input to Chassis - Basic	1500			Vrms
Isolation	Output to Chassis	500			Vdc

EMISSIONS AND IMMUNITY		
Characteristic	Standard	Compliance
Input Current Harmonics	IEC/EN 61000-3-2	Complies with Class A limits
Voltage Fluctuation and Flicker	IEC/EN 61000-3-3	Complies
Conducted Emissions	FCC 47 CFR Part15/CISPR22/EN55032	Class A with 6dB margin
ESD Immunity	IEC/EN 61000-4-2	±8KV Contact; ±15KV air discharge; Criteria A
Radiated Field Immunity	IEC/EN 61000-4-3	3V/m, 1KHz, 80% AM, 80MHz to 1GHz Criteria A <sup>2</sup>
Electrical Fast Transients/Burst Immunity	IEC/EN 61000-4-4	<sup>1</sup> Level 3 (2kV), criteria A
Surge Immunity	IEC/EN 61000-4-5	<sup>1</sup> Level 3 (2kV Line-Earth, 1kV Line-Line), criteria A
RF Conducted Immunity	IEC/EN 61000-4-6	Level 2 (3V/M) criteria A
Voltage Dips, Interruptions	IEC/EN 61000-4-11	230Vin, 100% load, Phase 0°, Dip 100% Duration 10ms (A) 230Vin, 50% load, Phase 0°, Dip 100% Duration 20ms (VSB:A, V1:B) 230Vin, 100% load, Phase 0°, Dip 100% Duration > 20ms (VSB, V1:B)

<sup>1</sup> measured at power supply's AC input connector <sup>2</sup> INSTALLED IN SYSTEM

<sup>2</sup> Contingent upon final system design

STATUS INDICATORS AND CONTROL SIGNALS (BI_COLOUR LED)	GREEN	AMBER
	LED Status (Power)	LED Status (Fault)
Standby - ON; Main output - OFF; AC PRESENT	Blinking green 1Hz	Off
Standby - ON; Main output - ON	Solid green	Off
Main output overcurrent, under voltage, overvoltage <sup>1</sup>	Off	On
FAN_FAULT; over temperature; standby overcurrent, under voltage <sup>1</sup>	Off	On
No AC Power	Off	Off
Power Supply Warning Event <sup>1</sup>	Off	Blinking
Cold Redundant mode – "COLD_STANDBY" / "FORCED STANDBY" MODE	Blinking green 2Hz	off

<sup>1</sup> coincides with PMBus™ Status Register(s) bit flags refer to [ACAN](#) for more information;

ADDR ADDRESS SELECTION			
ADDR pin (D4) resistor to GND (K-ohm)*	Power Supply Main Controller (Serial Communications Slave Address)	Power Supply External EEPROM (Serial Communications Slave Address)	
0.82	0xB0	0xA0	
2.7	0xB2	0xA2	
5.6	0xB4	0xA4	
8.2	0xB6	0xA6	
15	0xB8	0xA8	
27	0xBA	0xAA	
56	0xBC	0xAC	
180	0xBE	0xAE	

\* The resistor shall be +/-5% tolerance

Link to [Pin assignment table](#), [ADDR definition Table](#)

STATUS AND CONTROL SIGNALS			
Signal Name	I/O	Description	Interface Details
AC_OK/RAPID_ON Link to: <a href="#">Pin Table</a>	Output	<p>Multi-function signal and is configured as one of the following:</p> <p><b>AC_OK</b> (Default setting at initial power up): Output is driven high when input source is available and within acceptable limits. The output is driven low to indicate loss of input power. This signal de-asserts a minimum of 5ms before loss of main output and provides an accurate indication of loss of AC input voltage.</p> <p><b>RAPID_ON</b> is a two state analog signal forms the cold redundant bus with up to four (4) load connected PSUs. Apart from being tied to a common point at the system end, Only the PSU utilizes this signal as required for cold redundant mode, and must be configured via PMBus™; see <a href="#">ACAN-80 and 81</a> for details + <a href="#">wiring diagram</a>.</p> <p>Rapid_ON signal/bus provides these three functions:</p> <ul style="list-style-type: none"> <li>➤ Pull-up bus voltage: Bus pull-up is provided by the single PSU or the first PSU assigned the roll of “ACTIVE &amp; MASTER” aka “COLD_REDUNDANT ACTIVE”. More than one PSU can be assigned as “ACTIVE” only the first PSU assigned this roll provides the pull-up path and is why this PSU is referred to as the “Master”.</li> <li>➤ Each bus connected PSU drives the Rapid_ON bus low when any fault is detected.</li> <li>➤ Each bus connected PSU powers on its main output rapidly within 100µS after detection of LOW state.</li> </ul> <p><b>Note:</b> “Rapid_ON” pin configuration is retained once setup via PMBus™, even if AC power is recycled and remains the new default setting until commanded to INPUT_OK via PMBus™.</p>	<p><b>AC_OK</b> Pulled up via 511R to internal 5V bias supply and pulled down to DC Return via 10K OHM resistor.</p> <p><b>RAPID_ON:</b> Pulled 511R to 5V internal bias supply of the ACTIVE &amp; MASTER PSU; Pull-Down = 10K. Bus voltage reduces with the QTY of bus connected P</p>
PW_OK (Output OK) Link to: <a href="#">Pin Table</a>	Output	<p>The signal is asserted, driven high, by the power supply to indicate 12V main output is valid. Should a 12V main output fault occur, the PW_OK signal will de-assert + driven low. PW_OK output is driven low to indicate that the main output is outside of lower limit of regulation.</p>	<p>Pulled up internally via 10K to VDD<sup>1</sup>. A logic high &gt;2.0Vdc A logic low &lt;0.8Vdc Driven low by internal CMOS buffer (open drain output).</p>
SMB_ALERT (FAULT) Link to: <a href="#">Pin Table</a>	Output	<p>The signal output is driven low to indicate that the power supply has detected a fault / status register bits (except Status_CML) and is intended to alert the system. This output must be driven high when the power is operating correctly (within specified limits). The signal will revert to a high level when the fault stimulus (that caused the alert) is removed. The LED Status (Fault) reflects the status of SMB_ALERT signal</p>	<p>Pulled up internally via 10K to VDD<sup>1</sup>. A logic high &gt;2.0Vdc A logic low &lt;0.8Vdc Driven low by internal CMOS buffer (open drain output).</p>
PRESENT_L (Power Supply Absent) Link to: <a href="#">Pin Table</a>	Output	<p>The signal is used to detect the presence (installed) of a PSU by the host system. The signal is connected to PSU logic SGND within the power module.</p>	<p>Passive connection to +VSB_Return. A logic low &lt;0.8Vdc</p>
PS_ON (Main Out Enable/Disable) Link to: <a href="#">Pin Table</a>	Input	<p>This signal is pulled up, within the power supply, to the internal housekeeping supply. The power supply main 12Vdc output will be enabled when this signal is pulled low (to output return). In the low state the signal input shall not source more than 1mA of current. The 12Vdc output will be disabled when the input is driven higher than 2.4V, or open circuited. Cycling this signal shall clear latched fault conditions.</p>	<p>Pulled up internally via 10K to VDD<sup>1</sup>. A logic high &gt;2.0Vdc A logic low &lt;0.8Vdc Input is via CMOS Schmitt trigger buffer.</p>
ADDR (Address Select) Link to: <a href="#">Pin Table</a>	Input	<p>An analog input that is used to set the address of the internal slave devices (EEPROM and microprocessor) used for digital communications. Connection of a suitable resistor to +VSB_Return, in conjunction with an internal resistor divider chain, will configure the required address. See link to <a href="#">Address Selection Table</a></p>	<p>DC voltage between the limits of 0 and +3.3Vdc.</p>
SCL (Serial Clock) Link to Pin Table: Link to: <a href="#">Pin Table</a>	Both	<p>A serial clock line compatible with PMBus™ Power Systems Management Protocol Part 1 – General Requirements Rev 1.2. No additional internal capacitance is added that would affect the speed of the bus. The signal is provided with a series isolator device to disconnect the internal power supply bus in the event that the power module is unpowered.</p>	<p>VIL is 0.8V maximum VOL is 0.4V maximum when sinking 3mA VIH is 2.1V minimum</p>
SDA (Serial Data) Link to: <a href="#">Pin Table</a>	Both	<p>A serial data line compatible with PMBus™ Power Systems Management Protocol Part 1 – General Requirements Rev 1.2. The signal is provided with a series isolator device to disconnect the internal power supply bus in the event that the power module is unpowered.</p>	<p>VIL is 0.8V maximum VOL is 0.4V maximum when sinking 3mA VIH is 2.1V minimum</p>

STATUS AND CONTROL SIGNALS Continued:

Signal Name	I/O	Description	Interface Details
V1_SENSE & V1SENSE_RTN Link to: <a href="#">Pin_Table</a> <a href="#">Pin_Table</a>	Input	Remote sense connections intended to be connected at and sense the voltage at the point of load. The voltage sense will interact with the internal module regulation loop to compensate for voltage drops due to connection resistance between the output connector and the load. If remote sense compensation is not required then the voltage can be configured for local sense by: 1. V1_SENSE directly connected to main output 2. V1_SENSE_RTN directly connected to main output RTN	Compensation for up to 0.12Vdc total connection drop (output and return connections).
ISHARE Link to: <a href="#">Pin_table</a>	Both	This signal is connected between sharing units forming an ISHARE bus. It is a bi-directional analog bus voltage controls the current share between sharing units. PSU responds to change in bus voltage and also can change the bus voltage based on the load drawn from it. For single PSU, the voltage on the pin/ISHARE bus would read approximately 8VDC at 100% load. For two identical units sharing the same 100% load this would read approximately 4VDC for perfect current sharing (i.e. 50% module load capability per unit). This signal is also used by cold redundant enabled power supplies to determine Main output on/off state. Refer to <a href="#">ACAN-81</a> for details.	Analogue voltage: +8V maximum; 10K to +12V_RTN

<sup>1</sup>. VDD is an internal voltage rail derived from VSB and an internal housekeeping rail ("diode ORed") and is compatible with the voltage levels of TTL and CMOS logic families.

TIMING SPECIFICATIONS

Turn-On Delay & Output Rise Time:

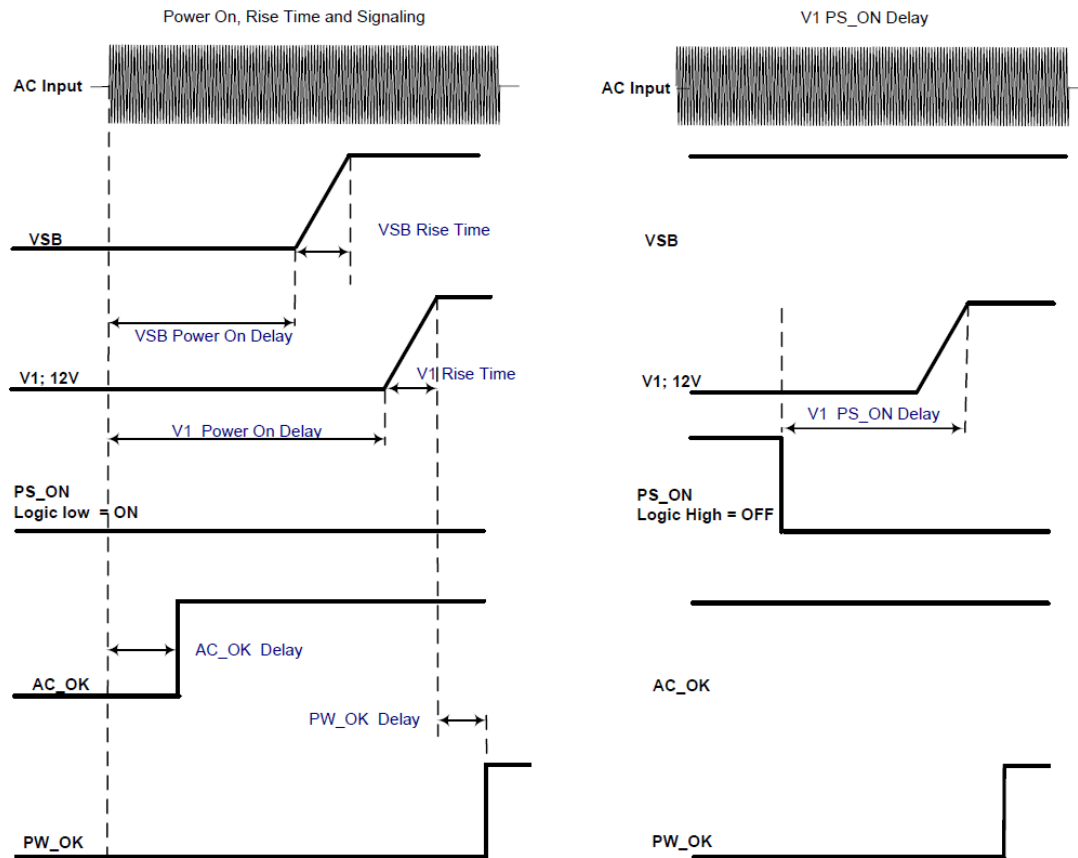

1. The turn-on delay after application of AC input within the operating range shall as defined in the following tables.
2. The output rise times shall be measured from 10% of the nominal output to the lower limit of the regulation band as defined in the following tables.

Time	Min	Max
Vsb Rise time	7ms	15ms
V1 Rise time	7ms	15ms
Vsb Power-on-delay		2700ms
V1 Power-on-delay		3000ms
V1 PS_ON delay	100ms	150ms
V1 PWOK delay	100ms	400ms
ACOK detect	250ms	1500ms

TIMING SPECIFICATIONS

Turn-Off (Shutdown by PS\_ON)



Turn-Off Timing	Min	Max	Notes
V1 Fall time	-	-	Must be monotonic
V1 PS_OFF delay	0ms	5ms	
PW_OK delay off	0.5ms		

1. Note this characteristic is applicable for the main 12Vdc output shutdown from PS\_ON pulled high (de-asserted).

TIMING SPECIFICATIONS

Power Removal Holdup

Power removed; holdup, falltime and signaling

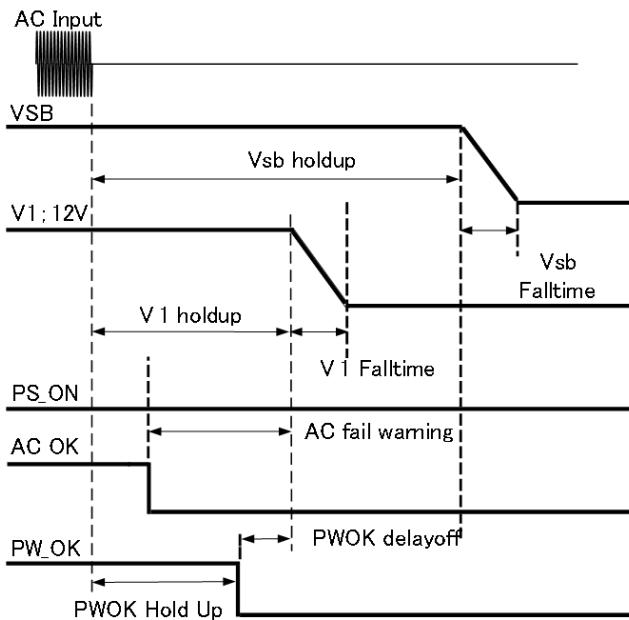

Power Removal Timing	Min	Typ.	Max	Notes
Vsb holdup	40ms		-	
V1 holdup	10ms		-	Full load (2000W)
AC Fail Warning	5ms		-	All load and input conditions
PWOK delay off	1ms		-	Full load (2000W)
Vsb Falltime	-		-	Must be monotonic
V1 Falltime	-		-	

**OUTPUT CONNECTOR & SIGNAL INTERFACE**

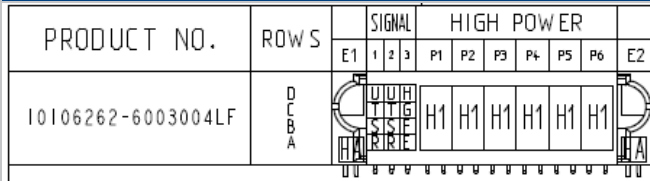

CODE	DESCRIPTION
E	MLBF SIGNAL CONTACT, ROW A (3.43)
F	MLBF SIGNAL CONTACT, ROW B (3.43)
G	MLBF SIGNAL CONTACT, ROW C (3.43)
H	MLBF SIGNAL CONTACT, ROW D (3.43)
H1	STD HIGH POWER CONTACT (3.43)
HA	METAL HOLD DOWN
R	STD SIGNAL CONTACT, ROW A (3.43)
S	STD SIGNAL CONTACT, ROW B (3.43)
T	STD SIGNAL CONTACT, ROW C (3.43)
U	STD SIGNAL CONTACT, ROW D (3.43)

**PIN ASSIGNMENTS - Power Module Output & Signal Interface Connector: FCI 10106262-6003004LF**

Pin	Signal Name	Comments
P4, P5, P6	V1	+ 12V main output
P1, P2, P3	V1 & V2 RETURN	+ 12V main and standby output return
A3	SDA	Short Pin <sup>1</sup> I2C data signal line; shorter MLFB pin; Link to definition table: <a href="#">STATUS AND CONTROL SIGNALS SDA</a>
B3	SCL	Short Pin <sup>1</sup> I2C clock signal line; shorter MLFB pin; Link to definition table: <a href="#">STATUS AND CONTROL SIGNALS SCL</a>
C3	PS_ON	Short Pin <sup>1</sup> Remote on/off Short; shorter MLFB pin; Link to definition table: <a href="#">STATUS AND CONTROL SIGNALS PS_ON</a>
D3	SMB_ALERT	Short Pin <sup>1</sup> 2C alert signal; shorter MLFB pin; Link to definition table: <a href="#">STATUS AND CONTROL SIGNALS SMB_ALERT</a>
A2	V1_SENSE_R	- Remote Sense/ return; Link to definition table: <a href="#">STATUS AND CONTROL SIGNALS V_Sense</a>
B2	V1_SENSE	+ Remote Sense; Link to definition table: <a href="#">STATUS AND CONTROL SIGNALS V_Sense</a>
C2	PW_OK	Power OK; Link to definition table: <a href="#">STATUS AND CONTROL SIGNALS SMB_PW_OK</a>
D2	ADDR	Address Selection (select by external pull down resistor); Link to selection table <a href="#">Address Selection Table</a> ; Link to definition table <a href="#">STATUS AND CONTROL SIGNALS ADDR</a>
A1	PRESENT_L	PS Present; Link to definition table <a href="#">STATUS AND CONTROL SIGNALS Present</a>
B1	VSB	Standby output
C1	AC_OK/ RAPID_ON_L	Default: AC_OK; Selectable via PMBus™; Link to definition table <a href="#">STATUS AND CONTROL SIGNALS AC_OK/RAPID_ON</a>
D1	ISHARE	Current share bus; Link to definition table <a href="#">STATUS AND CONTROL SIGNALS ISHARE</a>

<sup>1</sup> recessed (the shortest pin) in order to facilitate glitch free hot swap. It is "last to make, first to break" in the mating sequence.

**MATING CONNECTOR**

Part Number	Description
FCI 10106264-6003002LF	Right Angle
FCI 10106268-6003001LF	Straight Angle

WIRING DIAGRAM

Dotted lines show optional remote sense connections.  
Optional remote sense lines can be attached to a load that is a distance away from the power supply to improve regulation at the load.

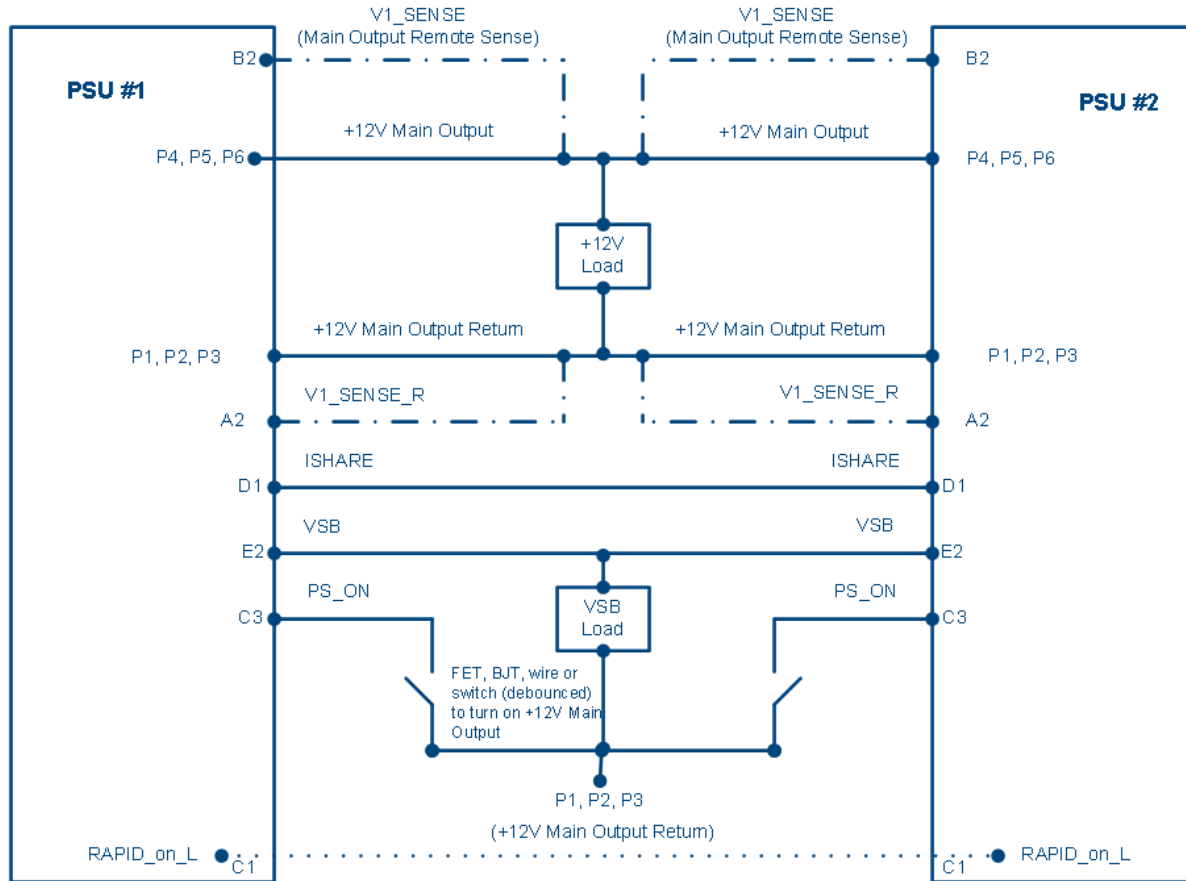

SMART\_ON application shown. For applications requiring AC\_OK signal, (default setting) refer to "signal" table for details

CURRENT SHARING NOTES

1. Main Output: Current sharing is achieved using the active current share method.
2. Current sharing can be achieved with or without the remote (V\_SENSE) connected to the common load.
3. +VSB Outputs can be tied together for redundancy but total combined output power must not exceed the rated standby power of a single unit. The +VSB output has an internal ORING MOSFET for additional redundancy/internal short protection.
4. Main output power of units sharing must not exceed the rated power of a single unit during power up.
5. The current sharing pin B5 is connected between sharing units (forming an ISHARE bus). It is an input and/or an output (bi-directional analog bus) as the voltage on the line controls the current share between sharing units. A power supply will respond to a change in this voltage but a power supply can also change the voltage depending on the load drawn from it. On a single unit the voltage on the pin (and the common ISHARE bus would read 8VDC at 100% load (power module capability). For two units sharing the same load this would read 4VDC for perfect current sharing (i.e. 50% power capability per unit).
6. The load for both the main 12V and the VSB rails at initial startup shall not be allowed to exceed the capability of a single unit. The load can be increased after a delay of 3sec (minimum), to allow all sharing units to achieve steady state regulation.



**MECHANICAL ENVELOPE**

THIS DRAWING IS ONLY A GRAPHICAL REPRESENTATION OF THE REAL PRODUCT AND MAY NOT SHOW ALL THE DETAILS ON THE PRODUCT.

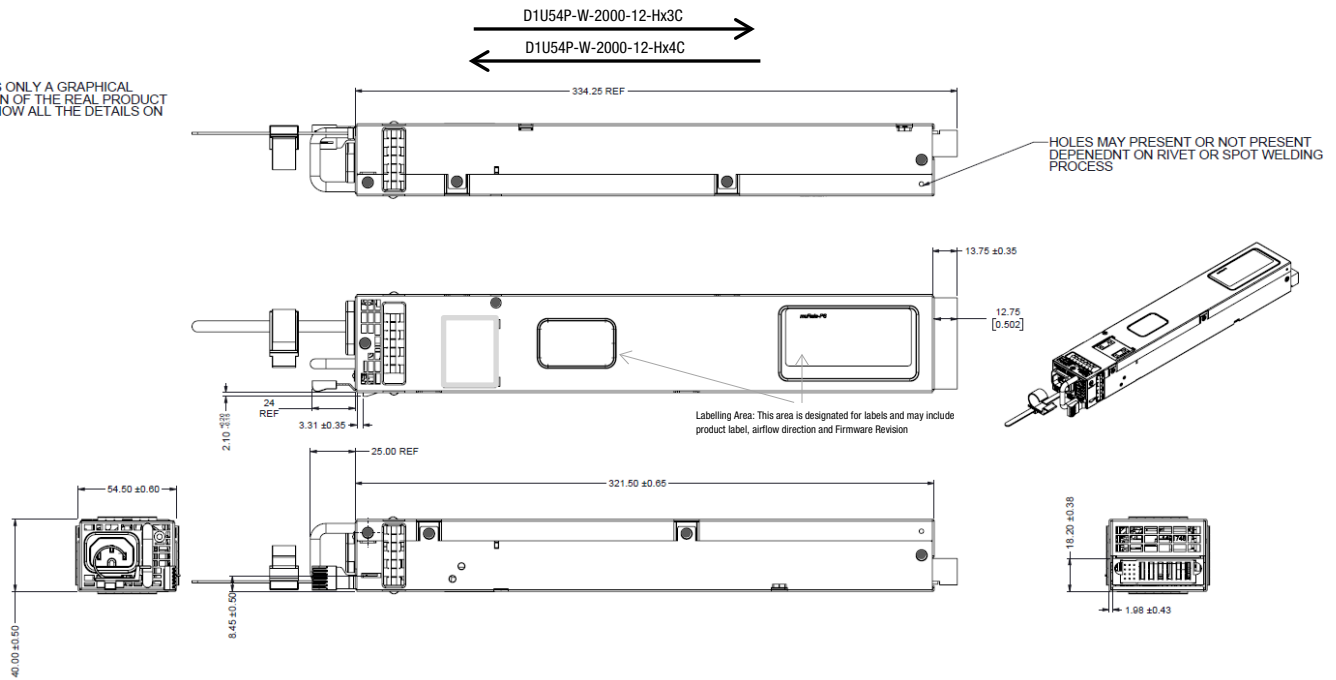

**AC Cord Retainer: Kang Yang SWPL-65-A**

CHASSIS HOLE  $\phi 5.0$   
CHASSIS THICKNESS 0.5~2.0mm



CABLE CLAMP

1. AC input connector: IEC 60320-C16
2. This drawing is a graphical representation of the product and may not show all fine details. Please contact Murata for 3D model for details
3. Reference File: \\tor-file06\mechanical\_design\Eng\_wip\UserPDDwg\1965\_1966\_1967\D75090019652\_DIMENSIONAL DRAWING AND BUSINESS SPEC Mar.15, 2018
4. Dimensions in mm, Material: 0.80mm hot dipped galvanized steel, Grade G60 minimum spangle finished with a CR(6+) free corrosion resistant coating
5. Product under development, subject to change. Contact factory for latest version.

**OPTIONAL ACCESSORIES**

Description	Part Number
Connector Card	D1U54P-12-CONC2K

**APPLICATION NOTES**

Document Number	Description	Link
ACAN-82	D1U54P-12-CONC2K , Output Connector Card	<a href="http://power.murata.com/datasheet?/data/apnotes/acan-82.pdf">http://power.murata.com/datasheet?/data/apnotes/acan-82.pdf</a>
ACAN-81	D1U54P-W-2000-12-HxxTC PBus™ Protocol	<a href="http://power.murata.com/datasheet?/data/apnotes/acan-81.pdf">http://power.murata.com/datasheet?/data/apnotes/acan-81.pdf</a>
ACAN-80	Cold Redundancy; RAPID_ON	<a href="http://power.murata.com/datasheet?/data/apnotes/acan-80.pdf">http://power.murata.com/datasheet?/data/apnotes/acan-80.pdf</a>

Murata Power Solutions, Inc.  
129 Flanders Rd. Westborough,  
Ma 01581, USA.  
ISO 9001 and 14001 REGISTERED



This product is subject to the following operating requirements and the Life and Safety Critical Application Sales Policy. Refer to: <http://www.murata-ps.com/requirements/>

Murata Power Solutions, Inc. ("Murata") makes no representation that the use of its products in the circuits described herein, or the use of other technical information contained herein, will not infringe upon existing or future patent rights. The descriptions contained herein do not imply the granting of licenses to make, use, or sell equipment constructed in accordance therewith. Buyer represents and agrees that it has all the necessary expertise to create and implement safeguards that anticipate dangerous consequences of failures, monitor failures and their consequences, lessen the likelihood of failures that might cause harm, and take appropriate remedial actions. Buyer will fully indemnify Murata, its affiliated companies, and its representatives against any damages arising out of the use of any Murata products in safety-critical applications. Specifications are subject to change without notice.

© 2018 Murata Power Solutions, Inc.

# Mouser Electronics

Authorized Distributor

Click to View Pricing, Inventory, Delivery & Lifecycle Information:

[Murata:](#)

[D1U54P-W-2000-12-HA3C](#) [D1U54P-W-2000-12-HA4C](#) [D1U54P-W-2000-12-HB3C](#) [D1U54P-W-2000-12-HB4C](#)  
[D1U54P-W-2000-12-HC3C](#) [D1U54P-W-2000-12-HC4C](#)



Компания «ЭлектроПласт» предлагает заключение долгосрочных отношений при поставках импортных электронных компонентов на взаимовыгодных условиях!

Наши преимущества:

- Оперативные поставки широкого спектра электронных компонентов отечественного и импортного производства напрямую от производителей и с крупнейших мировых складов;
- Поставка более 17-ти миллионов наименований электронных компонентов;
- Поставка сложных, дефицитных, либо снятых с производства позиций;
- Оперативные сроки поставки под заказ (от 5 рабочих дней);
- Экспресс доставка в любую точку России;
- Техническая поддержка проекта, помощь в подборе аналогов, поставка прототипов;
- Система менеджмента качества сертифицирована по Международному стандарту ISO 9001;
- Лицензия ФСБ на осуществление работ с использованием сведений, составляющих государственную тайну;
- Поставка специализированных компонентов (Xilinx, Altera, Analog Devices, Intersil, Interpoint, Microsemi, Aeroflex, Peregrine, Syfer, Eurofarad, Texas Instrument, Miteq, Cobham, E2V, MA-COM, Hittite, Mini-Circuits, General Dynamics и др.);

Помимо этого, одним из направлений компании «ЭлектроПласт» является направление «Источники питания». Мы предлагаем Вам помощь Конструкторского отдела:

- Подбор оптимального решения, техническое обоснование при выборе компонента;
- Подбор аналогов;
- Консультации по применению компонента;
- Поставка образцов и прототипов;
- Техническая поддержка проекта;
- Защита от снятия компонента с производства.



#### Как с нами связаться

**Телефон:** 8 (812) 309 58 32 (многоканальный)

**Факс:** 8 (812) 320-02-42

**Электронная почта:** [org@eplast1.ru](mailto:org@eplast1.ru)

**Адрес:** 198099, г. Санкт-Петербург, ул. Калинина, дом 2, корпус 4, литера А.