

Features

- High Voltage CMOS Technology
- Four Channel
- Positive Voltage Control
- CMOS device using TTL input levels
- Low Power Dissipation
- Low Cost Lead-Free SOIC-16 Plastic Package
- Halogen-Free “Green” Mold Compound
- RoHS* Compliant and 260°C Reflow Compatible

Description

The MADR-009190-000100 is a four channel driver used to translate TTL control inputs into gate control voltages for GaAs FET microwave switches and attenuators. High speed analog CMOS technology is utilized to achieve low power dissipation at moderate to high speeds, encompassing most microwave switching applications. The output HIGH level is optionally 0 to +2.0V (relative to GND) to optimize the intermodulation products of FET control devices at low frequencies. For driving PIN Diode circuits, the outputs are nominally switched between +5V & -5V. The actual driver output voltages will be lower when driving large currents due to the resistance of the output devices.

Functional Schematic

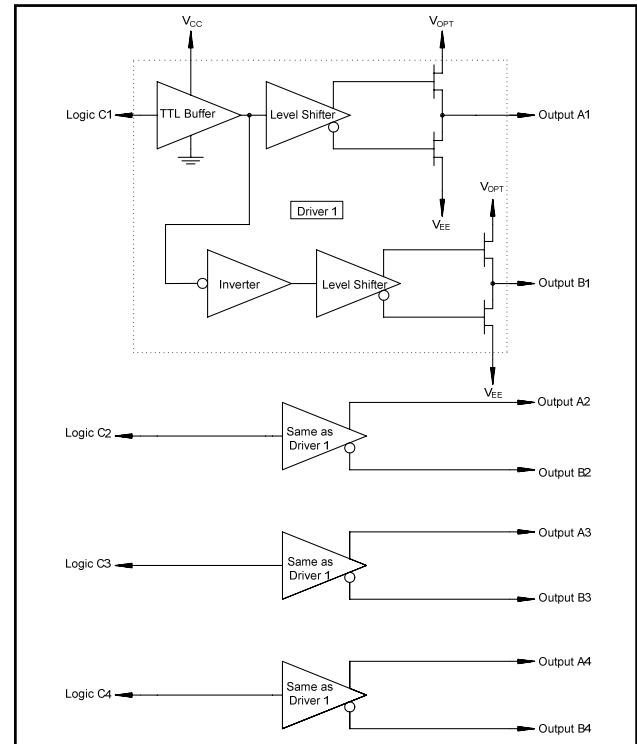

Ordering Information¹

Part Number	Package
MADR-009190-000100	Bulk Packaging
MADR-009190-000DIE	Die ²
MADR-009190-0001TR	1000 piece reel

1. Reference Application Note M513 for reel size information.
2. Die sales are available in wafer packs in increments of 100 pieces.

Pin Configuration³

Pin No.	Function	Pin No.	Function
1	V _{EE}	9	Output A1
2	V _{CC}	10	Output B1
3	C4	11	Output A2
4	C3	12	Output B2
5	C2	13	Output A3
6	C1	14	Output B3
7	V _{OPT}	15	Output A4
8	Ground	16	Output B4

3. The bottom of the die should be isolated for part number MADR-009190-000DIE.

* Restrictions on Hazardous Substances, European Union Directive 2002/95/EC.

Guaranteed Operating Ranges (for driving FET or PIN devices) ^{4,5,8}

Symbol	Parameter	Unit	Min.	Typ.	Max.
V_{CC}	Positive DC Supply Voltage	V	4.5	5.0	5.5
V_{EE}	Negative DC Supply Voltage	V	-10.5	-5.0	-4.5
$V_{OPT}^{6,7}$	Optional DC Output Supply Voltage	V	0	—	V_{CC}
$V_{OPT} - V_{EE}$	Negative Supply Voltage Range	V	4.5	Note 6,7	16.0
$V_{CC} - V_{EE}$	Positive to negative Supply Range	V	9.0	10.0	16.0
T_{OPER}	Operating Temperature	°C	-40	+25	+85
I_{OH}	DC Output Current - High	mA	-35	—	—
I_{OL}	DC Output Current - Low	mA	—	—	35
T_{rise}, T_{fall}	Maximum Input Rise or Fall Time	ns	—	—	500

4. Unused logic inputs must be tied to either GND or V_{CC} .
5. All voltages are relative to GND.
6. V_{OPT} is grounded in most cases when FETs are driven. To improve the intermodulation performance and the 1 dB compression point of GaAs control devices at low frequencies, V_{OPT} can be increased to between 1.0 and 2.0V. The nonlinear characteristics of the GaAs control devices will approximate performance at 500 MHz. It should be noted that the control current that is on the GaAs MMICs will increase when positive controls are applied.
7. When this driver is used to drive PIN diodes, V_{OPT} is often set to +5.0V, with V_{EE} set to -5.0V.
8. 0.01 uF decoupling capacitors are required on the power supply lines.

Handling Procedures

Please observe the following precautions to avoid damage:

Static Sensitivity

Silicon Integrated Circuits are sensitive to electrostatic discharge (ESD) and can be damaged by static electricity. Proper ESD control techniques should be used when handling these devices.

Truth Table

Input	Outputs	
Cn	An	Bn
Logic "0"	V_{EE}	V_{OPT}
Logic "1"	V_{OPT}	V_{EE}

DC Characteristics over Guaranteed Operating Range

Symbol	Parameter	Test Conditions	Units	Min.	Typ.	Max.
V_{IH}	Input High Voltage	Guaranteed High Input Voltage	V	2.0	—	—
V_{IL}	Input Low Voltage	Guaranteed Low Input Voltage	V	—	—	0.8
V_{OH}	Output High Voltage	$I_{OH} = -0.5 \text{ mA}$	V	$V_{OPT} - 0.1$	—	—
V_{OL}	Output Low Voltage	$I_{OL} = 0.5 \text{ mA}$	V	—	—	$V_{EE} + 0.1$
I_{IN}	Input Leakage Current (per Input)	$V_{IN} = V_{CC}$ or GND, $V_{EE} = \text{min}$, $V_{CC} = \text{max}$, $V_{OPT} = \text{min or max}$	nA	-250	—	250
I_{OH}	DC Output Current—High (per Output)	$V_{CC} = 5.0\text{V}$, $V_{EE} = -5.0\text{V}$, $V_{OPT} = 5.0\text{V}$	mA	-35	—	—
I_{OL}	DC Output Current—Low (per Output)	$V_{CC} = 5.0\text{V}$, $V_{EE} = -5.0\text{V}$, $V_{OPT} = 5.0\text{V}$	mA	—	—	35
I_{OH_SPIKE}	Peak Spike Output Current (Rising Edge) (per Output)	$V_{CC} = 5.0\text{V}$, $V_{EE} = -5.0\text{V}$, $V_{OPT} = 5.0\text{V}$, $C_L = 25 \text{ pF}$	mA	—	35	—
I_{OL_SPIKE}	Peak Spike Output Current (Falling Edge) (per Output)	$V_{CC} = 5.0\text{V}$, $V_{EE} = -5.0\text{V}$, $V_{OPT} = 5.0\text{V}$, $C_L = 25 \text{ pF}$	mA	—	50	—
I_{CC}	Quiescent Supply Current	$V_{IN} = V_{CC}$ or GND, $V_{EE} = -10.5\text{V}$, $V_{CC} = 5.5\text{V}$, $V_{OPT} = 5.5\text{V}$, No Output Load	μA	—	—	20
ΔI_{CC}	Additional Supply Current (per TTL Input pin)	$V_{CC} = \text{max}$, $V_{IN} = V_{CC} - 2.1\text{V}$	mA	—	—	1.0
I_{EE}	Quiescent Supply Current	$V_{IN} = V_{CC}$ or GND, $V_{EE} = -10.5\text{V}$, $V_{CC} = 5.5\text{V}$, $V_{OPT} = 5.5\text{V}$, No Output Load	μA	—	—	20
I_{OPT}	Quiescent Supply Current	$V_{IN} = V_{CC}$ or GND, $V_{EE} = -10.5\text{V}$, $V_{CC} = 5.5\text{V}$, $V_{OPT} = 5.5\text{V}$, No Output Load	μA	—	—	20
R_{NFET}	Output Resistance NFET On (to V_{EE})	$V_{CC} = 5.0\text{V}$, $V_{EE} = -5.0\text{V}$, $V_{OPT} = 5.0\text{V}$, $V_{OUT} = -4.9\text{V}$ +25°C, Note 9	Ω	—	40	—
R_{PFET}	Output Resistance PFET On (to V_{OPT})	$V_{CC} = 5.0\text{V}$, $V_{EE} = -5.0\text{V}$, $V_{OPT} = 5.0\text{V}$, $V_{OUT} = 4.9\text{V}$ +25°C, Note 9	Ω	—	45	—

9. See plot of R_{NFET} and R_{PFET} for variations over temperature for driving 4.99k and 82 ohm resistive load. (Note that this corresponds to 1 mA and 33 mA currents at 25°).

AC Characteristics Over Guaranteed Operating Range ¹⁰

Symbol	Parameter	Typical performance			Unit
		-40°C	+25°C	+85°C	
T _{PLH}	Propagation Delay	20	22	25	ns
T _{PHL}	Propagation Delay	20	22	25	ns
T _{TLH}	Output Transition Time (Rising Edge)	5	6	8	ns
T _{THL}	Output Transition Time (Falling Edge)	5	6	8	ns
T _{skew}	Delay Skew	2	2	2	ns
PRF (max)	50% Duty Cycle	DC	—	10	MHz
C _{IN}	Input Capacitance	5	5	5	pF
C _{PDC}	Power Dissipation Capacitance ¹¹	50	50	50	pF
C _{PDE}	Power Dissipation Capacitance ¹¹	100	100	100	pF

10. V_{CC} = 4.5V, V_{OPT} = 0V, V_{EE} = min or max, C_L = 25 pF, input LOGIC1 = 3V, LOGIC0 = 0V, Trise, Tfall = 6 ns.

11. Total Power Dissipation is calculated by the following formula: PD = V_{CC}²fC_{PDC} + V_{EE}²fC_{PDE}

Switching Waveforms

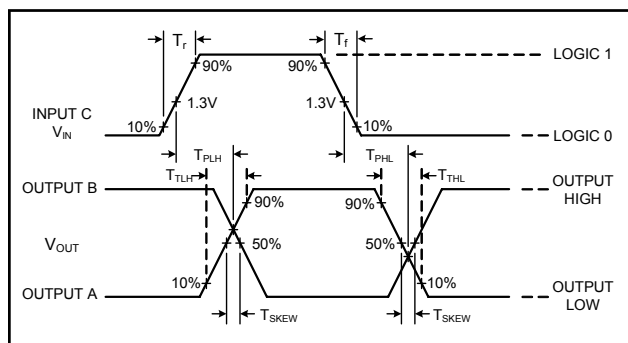

Output Resistance vs. Temperature ¹²

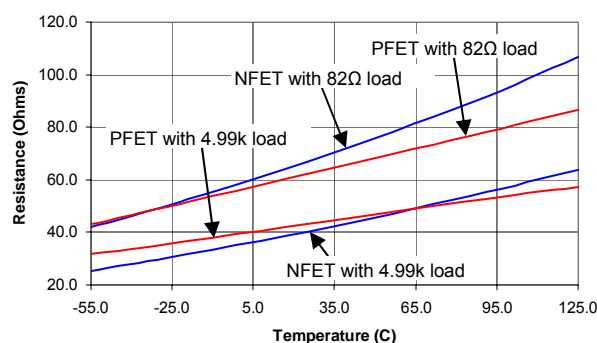

12. Output resistance were measured under the condition of V_{CC} = 5.0V, V_{OPT} = 5.0V, and V_{EE} = -5.0V, with load resistors from outputs to ground.

Absolute Maximum Ratings¹³

Symbol	Parameter	Min	Max	Unit
V_{CC}	Positive DC Supply Voltage	-0.5	7.0	V
I_{CC}	Positive DC Supply Current ($-0.5V \leq V_{IN} \leq 0.8V$; $2.0V \leq V_{IN} \leq V_{CC} + 0.5V$; $V_{CC} - V_{IN} \leq 7.0V$)	—	20	mA
V_{EE}	Negative DC Supply Voltage	-11.0	0.5	V
I_{EE}	Negative DC Supply Current (per Output) ¹⁴	-50	—	mA
V_{OPT}	Optional DC Output Supply Voltage	-0.5	$V_{CC} + 0.5$	V
I_{OPT}	Optional DC Output Supply Current (per Output) ¹⁴	—	50	V
$V_{OPT} - V_{EE}$	Output to Negative Supply Voltage Range	-0.5	18.0	V
$V_{CC} - V_{EE}$	Positive to Negative Supply Voltage Range	-0.5	18.0	V
V_{IN}	DC Input Voltage	-0.5 Note 15	$V_{CC} + 0.5$	V
V_O	DC Output Voltage	$V_{EE} - 0.5$	$V_{OPT} + 0.5$	V
P_D ¹⁶	Power Dissipation in Still Air	—	500	mW
T_{OPER}	Operating Temperature	-55	125	°C
T_{STG}	Storage Temperature	-65	150	°C
ESD	ESD Sensitivity	2.0	—	kV

13. All voltages are referenced to GND. All inputs and outputs incorporate latch-up protection structures.

14. The maximum I_{EE} and I_{OPT} are specified under the condition of $V_{CC} = 5.5V$, $V_{EE} = -5.5V$, $V_{OPT} = 5.5V$, and the total power dissipation is within 500 mW in still air.

15. If $V_{CC} \geq 6.5V$, then the minimum for V_{IN} is $V_{CC} - 7.0V$.

16. Derate -7 mW/°C from 65°C to 85°C.

Equivalent Output Circuit for An and Bn Outputs (33 mA load at 25°)

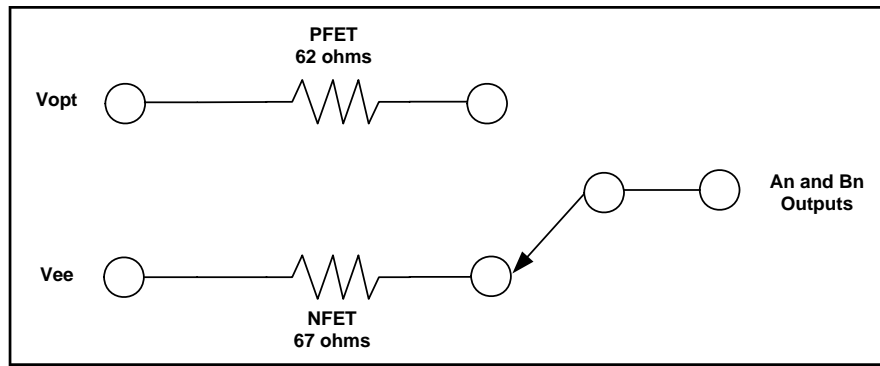

Typical Application for a SPDT Switch ^{17,18}

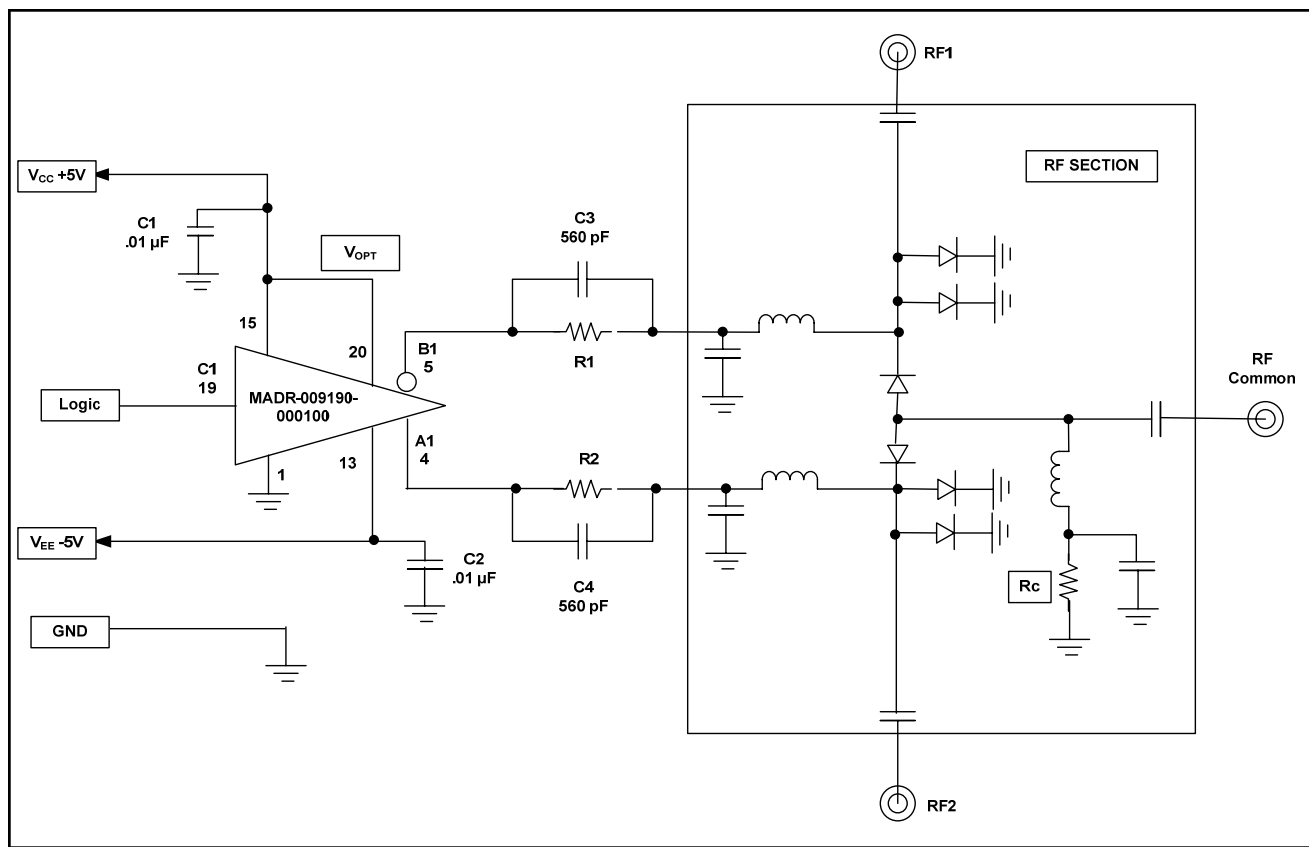

17. Note that the description of the above circuit is on the following page.

18. Only one section of MADR-009190-000100 is shown. The other three sections will have equivalent performance.

Quad Driver for GaAs FET or PIN Diode Switches and Attenuators

Rev. 4

Description of Circuit

The MADR-009190-000100 provides four pairs of complementary outputs that are each capable of driving a maximum of ± 35 mA into a load. In addition, with proper capacitor selection (C3 & C4) used in parallel with the current setting resistor (R1 & R2), additional spiking current can be achieved.

To achieve the Non-Inverting and Inverting complementary voltages, each output is switched between two internal FETs. The FETs are connected to V_{OPT} for the positive output and V_{EE} for the negative output. V_{OPT} and V_{EE} are adjustable for various configurations and have the following limitations: V_{EE} can be no more negative than -10.5 volts; V_{OPT} can be no more positive than $+5.5$ volts AND V_{OPT} must always be less than or equal to V_{CC} . Increasing V_{OPT} beyond V_{CC} will prevent the device from switching states when commanded to by the logic input. The most common configuration is to drive V_{EE} at -5.0 volts with V_{CC} and V_{OPT} tied together at $+5.0$ volts.

Lead-Free, SOIC-16[†]

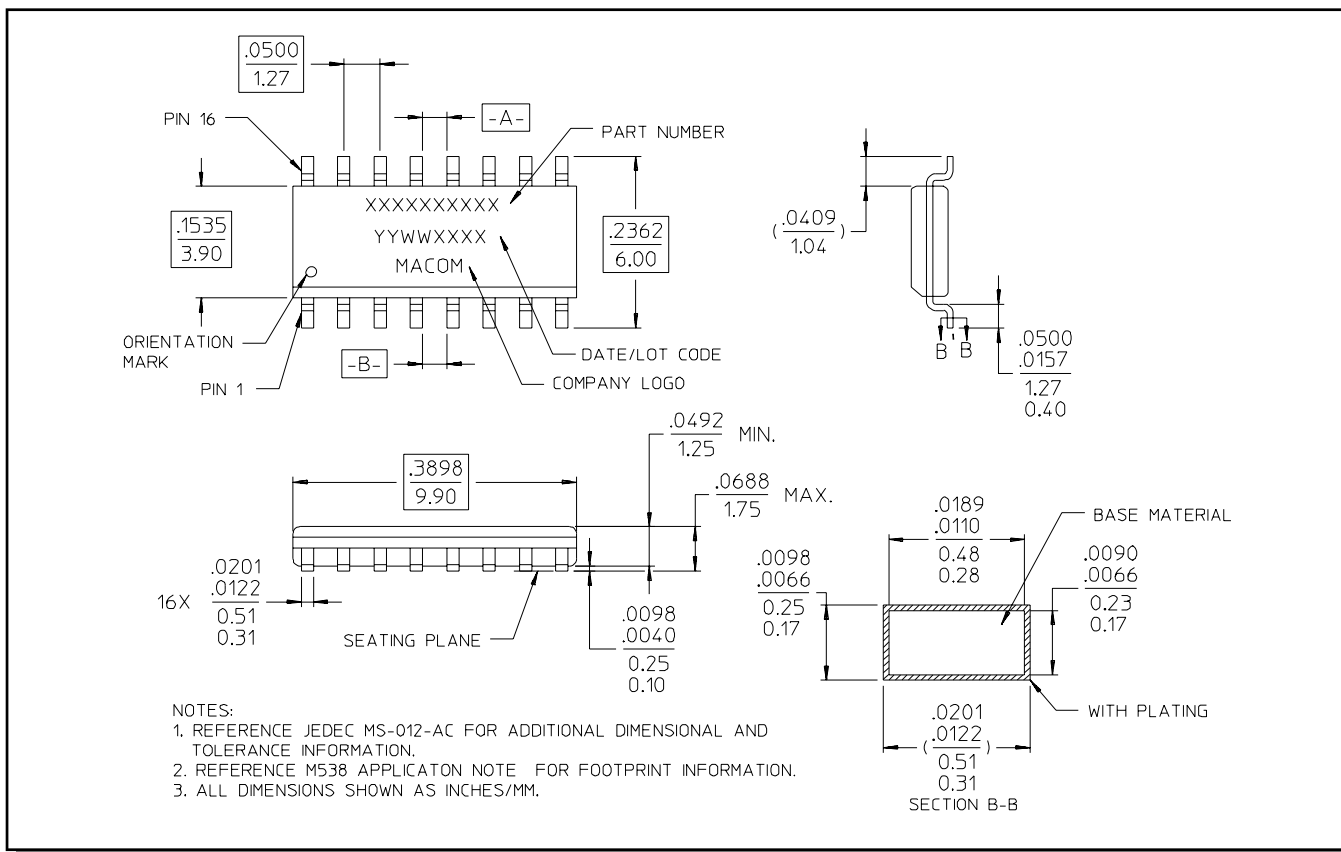

[†] Reference Application Note M538 for lead-free solder reflow recommendations. Plating is 100% matte tin over copper.

Die Outline

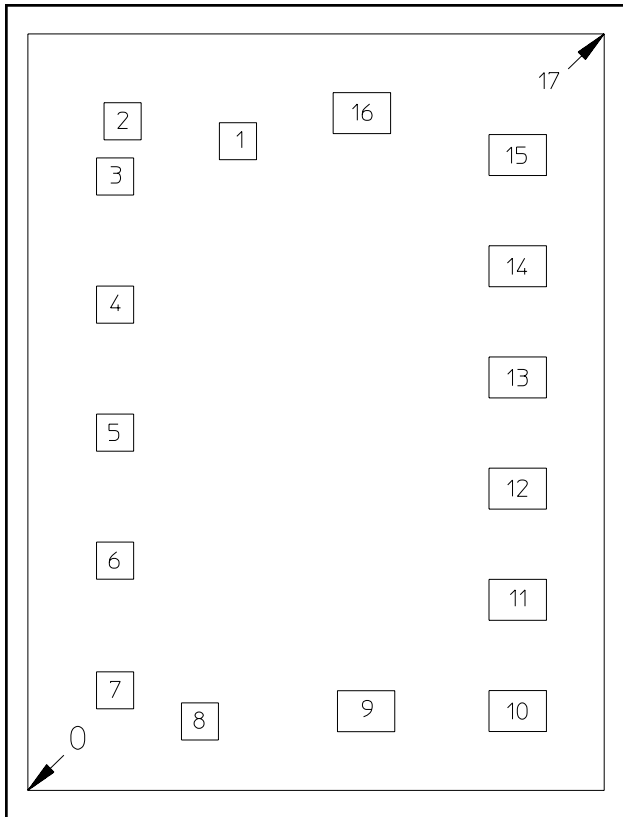

Pad Configuration^{19,20}

Die Size: 1325 x 1735 μm (nominal)

Pad No.	X (μm) nominal	Y (μm) nominal	Pad Size (μm) X x Y
0	0	0	Lower left edge of die
1	482.95	1489	85 x 85
2	217.85	1534.6	85 x 85
3	200.45	1407.9	85 x 85
4	200.45	1114.2	85 x 85
5	200.45	820.45	85 x 85
6	200.45	526.8	85 x 85
7	200.45	229.35	85 x 85
8	395.6	157.95	85 x 85
9	777.55	181.5	132 x 94
10	1126.35	181.75	132 x 94
11	1126.35	436.85	132 x 94
12	1126.35	691.95	132 x 94
13	1126.35	947.05	132 x 94
14	1126.35	1202.15	132 x 94
15	1126.35	1457.3	132 x 94
16	767.9	1553.5	132 x 94
17	1325	1735	Upper right edge of die

19. All X,Y dimensions are at bond pad center.
20. Die thickness is 8.0 mils.



Компания «ЭлектроПласт» предлагает заключение долгосрочных отношений при поставках импортных электронных компонентов на взаимовыгодных условиях!

Наши преимущества:

- Оперативные поставки широкого спектра электронных компонентов отечественного и импортного производства напрямую от производителей и с крупнейших мировых складов;
- Поставка более 17-ти миллионов наименований электронных компонентов;
- Поставка сложных, дефицитных, либо снятых с производства позиций;
- Оперативные сроки поставки под заказ (от 5 рабочих дней);
- Экспресс доставка в любую точку России;
- Техническая поддержка проекта, помощь в подборе аналогов, поставка прототипов;
- Система менеджмента качества сертифицирована по Международному стандарту ISO 9001;
- Лицензия ФСБ на осуществление работ с использованием сведений, составляющих государственную тайну;
- Поставка специализированных компонентов (Xilinx, Altera, Analog Devices, Intersil, Interpoint, Microsemi, Aeroflex, Peregrine, Syfer, Eurofarad, Texas Instrument, Miteq, Cobham, E2V, MA-COM, Hittite, Mini-Circuits, General Dynamics и др.);

Помимо этого, одним из направлений компании «ЭлектроПласт» является направление «Источники питания». Мы предлагаем Вам помощь Конструкторского отдела:

- Подбор оптимального решения, техническое обоснование при выборе компонента;
- Подбор аналогов;
- Консультации по применению компонента;
- Поставка образцов и прототипов;
- Техническая поддержка проекта;
- Защита от снятия компонента с производства.



Как с нами связаться

Телефон: 8 (812) 309 58 32 (многоканальный)

Факс: 8 (812) 320-02-42

Электронная почта: org@eplast1.ru

Адрес: 198099, г. Санкт-Петербург, ул. Калинина, дом 2, корпус 4, литера А.