

FP-BGA
Commercial Temp
Industrial Temp

128K x 8
1Mb Asynchronous SRAM

7, 8, 10, 12 ns
3.3 V V_{DD}
Center V_{DD} and V_{SS}

Features

- Fast access time: 7, 8, 10, 12 ns
- CMOS low power operation: 140/120/95/80 mA at minimum cycle time
- Single 3.3 V power supply
- All inputs and outputs are TTL-compatible
- Fully static operation
- Industrial Temperature Option: -40° to 85°C
- Package line up
 - U: 6 mm x 8 mm Fine Pitch Ball Grid Array package
 - GU: RoHS-compliant 6 mm x 8 mm Fine Pitch Ball Grid Array package

Description

The GS71108A is a high speed CMOS Static RAM organized as 131,072 words by 8 bits. Static design eliminates the need for external clocks or timing strobes. The GS 71108 operates on a single 3.3 V power supply and all inputs and outputs are TTL-compatible. The GS71108A is available in the 6 mm x 8 mm Fine Pitch BGA package.

Fine Pitch BGA 128K x 8-Bump Configuration

	1	2	3	4	5	6
A	NC	$\overline{\text{OE}}$	A2	A6	A7	NC
B	DQ1	NC	A1	A5	$\overline{\text{CE}}$	DQ8
C	DQ2	NC	A0	A4	NC	DQ7
D	V_{SS}	NC	NC	A3	NC	V_{DD}
E	V_{DD}	NC	NC	NC	NC	V_{SS}
F	DQ3	NC	A14	A11	DQ5	DQ6
G	DQ4	NC	A15	A12	$\overline{\text{WE}}$	A8
H	NC	A10	A16	A13	A9	NC

Package U
6 mm x 8 mm, 0.75 mm Bump Pitch
Top View

Pin Descriptions

Symbol	Description
A ₀ –A ₁₆	Address input
DQ ₁ –DQ ₈	Data input/output
$\overline{\text{CE}}$	Chip enable input
$\overline{\text{WE}}$	Write enable input
$\overline{\text{OE}}$	Output enable input
V_{DD}	+3.3 V power supply
V_{SS}	Ground
NC	No connect

Block Diagram

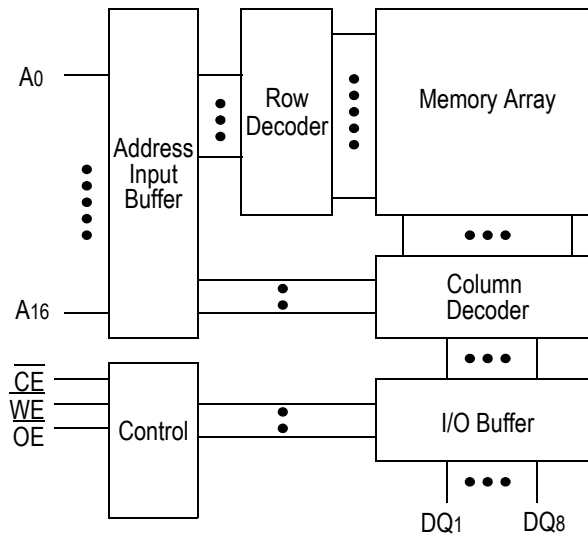

Truth Table

\overline{CE}	\overline{OE}	\overline{WE}	DQ1 to DQ8	V_{DD} Current
H	X	X	Not Selected	ISB1, ISB2
L	L	H	Read	IDD
L	X	L	Write	
L	H	H	High Z	

Note:
X: "H" or "L"

Absolute Maximum Ratings

Parameter	Symbol	Rating	Unit
Supply Voltage	V _{DD}	-0.5 to +4.6	V
Input Voltage	V _{IN}	-0.5 to V _{DD} +0.5 (≤ 4.6 V max.)	V
Output Voltage	V _{OUT}	-0.5 to V _{DD} +0.5 (≤ 4.6 V max.)	V
Allowable power dissipation	PD	0.7	W
Storage temperature	T _{STG}	-55 to 150	°C

Note:

Permanent device damage may occur if Absolute Maximum Ratings are exceeded. Functional operation shall be restricted to Recommended Operating Conditions. Exposure to higher than recommended voltages for extended periods of time could affect device reliability.

Recommended Operating Conditions

Parameter	Symbol	Min	Typ	Max	Unit
Supply Voltage for -7/-8/-10/-12	V _{DD}	3.0	3.3	3.6	V
Input High Voltage	V _{IH}	2.0	—	V _{DD} +0.3	V
Input Low Voltage	V _{IL}	-0.3	—	0.8	V
Ambient Temperature, Commercial Range	T _{Ac}	0	—	70	°C
Ambient Temperature, Industrial Range	T _{AI}	-40	—	85	°C

Notes:

1. Input overshoot voltage should be less than V_{DD} +2 V and not exceed 20 ns.
2. Input undershoot voltage should be greater than -2 V and not exceed 20 ns.

Capacitance

Parameter	Symbol	Test Condition	Max	Unit
Input Capacitance	C _{IN}	V _{IN} = 0 V	5	pF
Output Capacitance	C _{OUT}	V _{OUT} = 0 V	7	pF

Notes:

1. Tested at T_A = 25°C, f = 1 MHz
2. These parameters are sampled and are not 100% tested.

DC I/O Pin Characteristics

Parameter	Symbol	Test Conditions	Min	Max
Input Leakage Current	I _{IL}	V _{IN} = 0 to V _{DD}	-1 uA	1 uA
Output Leakage Current	I _{LO}	Output High Z V _{OUT} = 0 to V _{DD}	-1 uA	1 uA
Output High Voltage	V _{OH}	I _{OH} = -4 mA	2.4	—
Output Low Voltage	V _{OL}	I _{LO} = +4 mA	—	0.4 V

Power Supply Currents

Parameter	Symbol	Test Conditions	0 to 70°C				-40 to 85°C			
			7 ns	8 ns	10 ns	12 ns	7 ns	8 ns	10 ns	12 ns
Operating Supply Current	I _{DD}	$\overline{CE} \leq V_{IL}$ All other inputs $\geq V_{IH}$ or $\leq V_{IL}$ Min. cycle time I _{OUT} = 0 mA	140 mA	120 mA	95 mA	80 mA	145 mA	125 mA	100 mA	85 mA
Standby Current	I _{SB1}	$\overline{CE} \geq V_{IH}$ All other inputs $\geq V_{IH}$ or $\leq V_{IL}$ Min. cycle time	25 mA	20 mA	20 mA	15 mA	30 mA	25 mA	25 mA	20 mA
Standby Current	I _{SB2}	$\overline{CE} \geq V_{DD} - 0.2 V$ All other inputs $\geq V_{DD} - 0.2 V$ or $\leq 0.2 V$	2 mA				5 mA			

AC Test Conditions

Parameter	Conditions
Input high level	$V_{IH} = 2.4\text{ V}$
Input low level	$V_{IL} = 0.4\text{ V}$
Input rise time	$t_r = 1\text{ V/ns}$
Input fall time	$t_f = 1\text{ V/ns}$
Input reference level	1.4 V
Output reference level	1.4 V
Output load	Fig. 1 & 2

Notes:

1. Include scope and jig capacitance.
2. Test conditions as specified with output loading as shown in **Fig. 1** unless otherwise noted.
3. Output load 2 for t_{LZ} , t_{HZ} , t_{OLZ} and t_{OHZ}



AC Characteristics

Read Cycle

Parameter	Symbol	-7		-8		-10		-12		Unit
		Min	Max	Min	Max	Min	Max	Min	Max	
Read cycle time	t_{RC}	7	—	8	—	10	—	12	—	ns
Address access time	t_{AA}	—	7	—	8	—	10	—	12	ns
Chip enable access time (\overline{CE})	t_{AC}	—	7	—	8	—	10	—	12	ns
Output enable to output valid (\overline{OE})	t_{OE}	—	3	—	3.5	—	4	—	5	ns
Output hold from address change	t_{OH}	3	—	3	—	3	—	3	—	ns
Chip enable to output in low Z (\overline{CE})	t_{LZ}^*	3	—	3	—	3	—	3	—	ns
Output enable to output in low Z (\overline{OE})	t_{OLZ}^*	0	—	0	—	0	—	0	—	ns
Chip disable to output in High Z (\overline{CE})	t_{HZ}^*	—	3.5	—	4	—	5	—	6	ns
Output disable to output in High Z (\overline{OE})	t_{OHZ}^*	—	3	—	3.5	—	4	—	5	ns

* These parameters are sampled and are not 100% tested

Read Cycle 1: $\overline{CE} = \overline{OE} = V_{IL}$, $\overline{WE} = V_{IH}$



Read Cycle 2: $\overline{WE} = V_{IH}$



Write Cycle

Parameter	Symbol	-7		-8		-10		-12		Unit
		Min	Max	Min	Max	Min	Max	Min	Max	
Write cycle time	tWC	7	—	8	—	10	—	12	—	ns
Address valid to end of write	tAW	5	—	5.5	—	7	—	8	—	ns
Chip enable to end of write	tCW	5	—	5.5	—	7	—	8	—	ns
Data set up time	tDW	3	—	4	—	5	—	6	—	ns
Data hold time	tDH	0	—	0	—	0	—	0	—	ns
Write pulse width	tWP	5	—	5.5	—	7	—	8	—	ns
Address set up time	tAS	0	—	0	—	0	—	0	—	ns
Write recovery time (\overline{WE})	tWR	0	—	0	—	0	—	0	—	ns
Write recovery time (\overline{CE})	tWR1	0	—	0	—	0	—	0	—	ns
Output Low Z from end of write	tWLZ*	3	—	3	—	3	—	3	—	ns
Write to output in High Z	tWHZ*	—	3	—	3.5	—	4	—	5	ns

* These parameters are sampled and are not 100% tested



Write Cycle 2: \overline{CE} control



6 mm x 8 mm Fine Pitch BGA

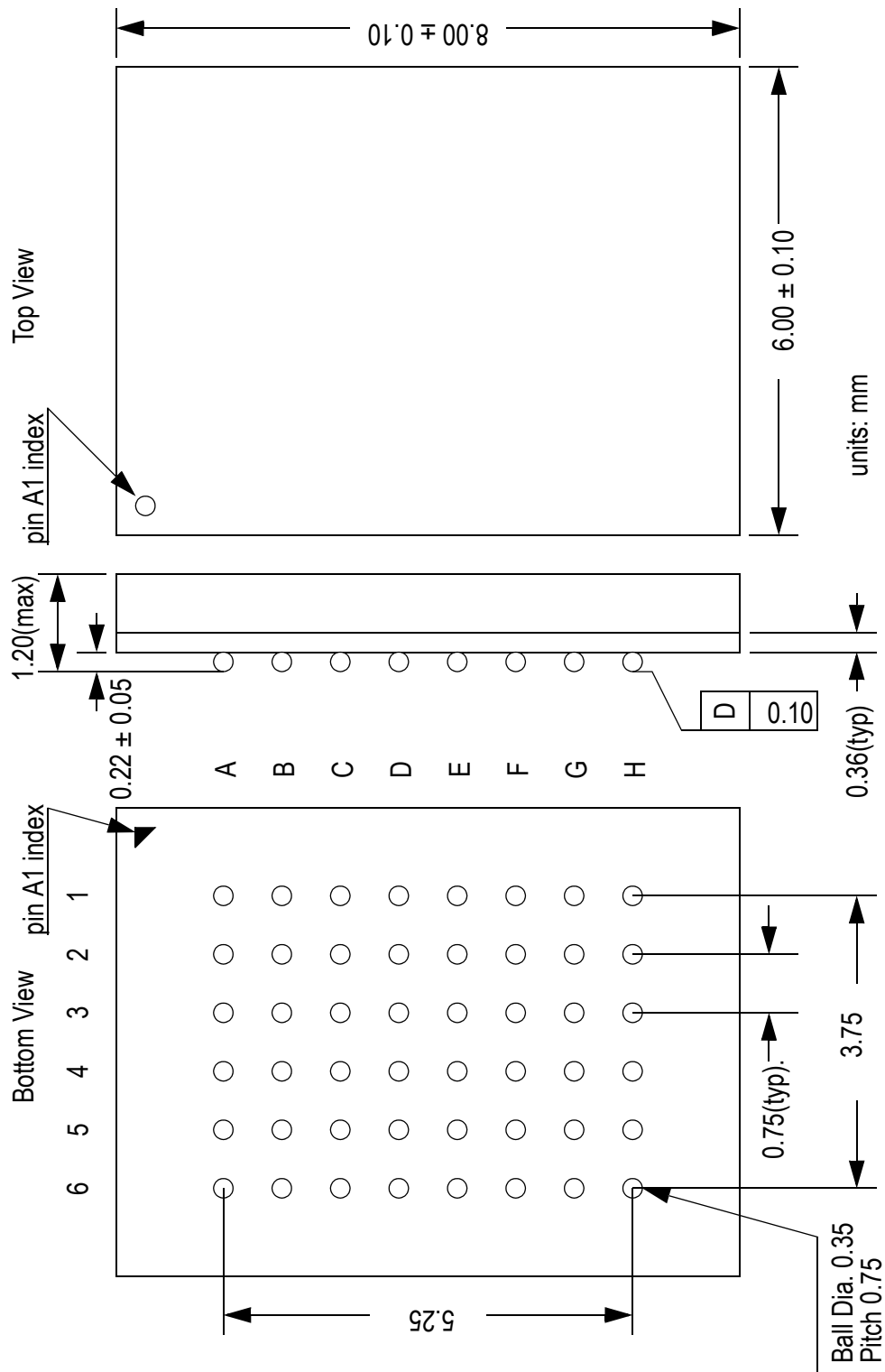

Ordering Information

Part Number*	Package	Access Time	Temp. Range
GS71108AU-7	6 mm x 8 mm Fine Pitch BGA	7 ns	Commercial
GS71108AU-8	6 mm x 8 mm Fine Pitch BGA	8 ns	Commercial
GS71108AU-10	6 mm x 8 mm Fine Pitch BGA	10 ns	Commercial
GS71108AU-12	6 mm x 8 mm Fine Pitch BGA	12 ns	Commercial
GS71108AU-7I	6 mm x 8 mm Fine Pitch BGA	7 ns	Industrial
GS71108AU-8I	6 mm x 8 mm Fine Pitch BGA	8 ns	Industrial
GS71108AU-10I	6 mm x 8 mm Fine Pitch BGA	10 ns	Industrial
GS71108AU-12I	6 mm x 8 mm Fine Pitch BGA	12 ns	Industrial
GS71108AGU-7	RoHS-compliant 6 mm x 8 mm Fine Pitch BGA	7 ns	Commercial
GS71108AGU-8	RoHS-compliant 6 mm x 8 mm Fine Pitch BGA	8 ns	Commercial
GS71108AGU-10	RoHS-compliant 6 mm x 8 mm Fine Pitch BGA	10 ns	Commercial
GS71108AGU-12	RoHS-compliant 6 mm x 8 mm Fine Pitch BGA	12 ns	Commercial
GS71108AGU-7I	RoHS-compliant 6 mm x 8 mm Fine Pitch BGA	7 ns	Industrial
GS71108AGU-8I	RoHS-compliant 6 mm x 8 mm Fine Pitch BGA	8 ns	Industrial
GS71108AGU-10I	RoHS-compliant 6 mm x 8 mm Fine Pitch BGA	10 ns	Industrial
GS71108AGU-12I	RoHS-compliant 6 mm x 8 mm Fine Pitch BGA	12 ns	Industrial

Note:

Customers requiring delivery in Tape and Reel should add the character "T" to the end of the part number. For example: GS71108AU-8T.

1Mb Asynchronous Datasheet Revision History

Rev. Code: Old; New	Types of Changes Format or Content	Page #/Revisions/Reason
71108A_r1		• Creation of new datasheet
71108A_r1; 71108A_r1_01	Content	• Added 6 ns speed bin to entire document
71108A_r1_01; 71108A_r1_02	Content	• Updated all power numbers • Changed 6 mm x 10 mm package designator from U to X
71108A_r1_02; 71108A_r1_03	Content	• Updated Recommended Operating Conditions table on page 3 • Updated Power Supply Currents table • Changed FPBGA package from 6 x 10 to 6 x 8 (package U)
71108A_r1_03; 71108A_r1_04	Content	• Removed 6 ns speed bin from entire document • Added 7 ns speed bin to entire document
71108A_r1_04; 71108A_r1_05	Content	• Added missing 300 mil SOJ mechanical drawing
71108A_r1_05; 71108A_r1_06	Content	• Updated format • Added RoHS-compliant information for TSOP-II package
71108A_r1_06; 71108A_r1_07	Content	• Added RoHS-compliant information for FP-BGA package
71108A_r1_07; 71108A_r1_08	Content	• Added RoHS-compliant 400 mil, 32-pin SOJ
71108A_r1_08; 71108A_r1_09	Content	• Updated to MP in ordering information table
71108A_r1_09; 71108A_r1_10	Content	• Removed Status column from Ordering Information Table • Removed SOJ package reference from entire document • (Rev1.10a: Removed TSOP-II references due to EOL (EOL_091016111-CY)



Компания «ЭлектроПласт» предлагает заключение долгосрочных отношений при поставках импортных электронных компонентов на взаимовыгодных условиях!

Наши преимущества:

- Оперативные поставки широкого спектра электронных компонентов отечественного и импортного производства напрямую от производителей и с крупнейших мировых складов;
- Поставка более 17-ти миллионов наименований электронных компонентов;
- Поставка сложных, дефицитных, либо снятых с производства позиций;
- Оперативные сроки поставки под заказ (от 5 рабочих дней);
- Экспресс доставка в любую точку России;
- Техническая поддержка проекта, помощь в подборе аналогов, поставка прототипов;
- Система менеджмента качества сертифицирована по Международному стандарту ISO 9001;
- Лицензия ФСБ на осуществление работ с использованием сведений, составляющих государственную тайну;
- Поставка специализированных компонентов (Xilinx, Altera, Analog Devices, Intersil, Interpoint, Microsemi, Aeroflex, Peregrine, Syfer, Eurofarad, Texas Instrument, Miteq, Cobham, E2V, MA-COM, Hittite, Mini-Circuits, General Dynamics и др.);

Помимо этого, одним из направлений компании «ЭлектроПласт» является направление «Источники питания». Мы предлагаем Вам помощь Конструкторского отдела:

- Подбор оптимального решения, техническое обоснование при выборе компонента;
- Подбор аналогов;
- Консультации по применению компонента;
- Поставка образцов и прототипов;
- Техническая поддержка проекта;
- Защита от снятия компонента с производства.



Как с нами связаться

Телефон: 8 (812) 309 58 32 (многоканальный)

Факс: 8 (812) 320-02-42

Электронная почта: org@eplast1.ru

Адрес: 198099, г. Санкт-Петербург, ул. Калинина, дом 2, корпус 4, литера А.