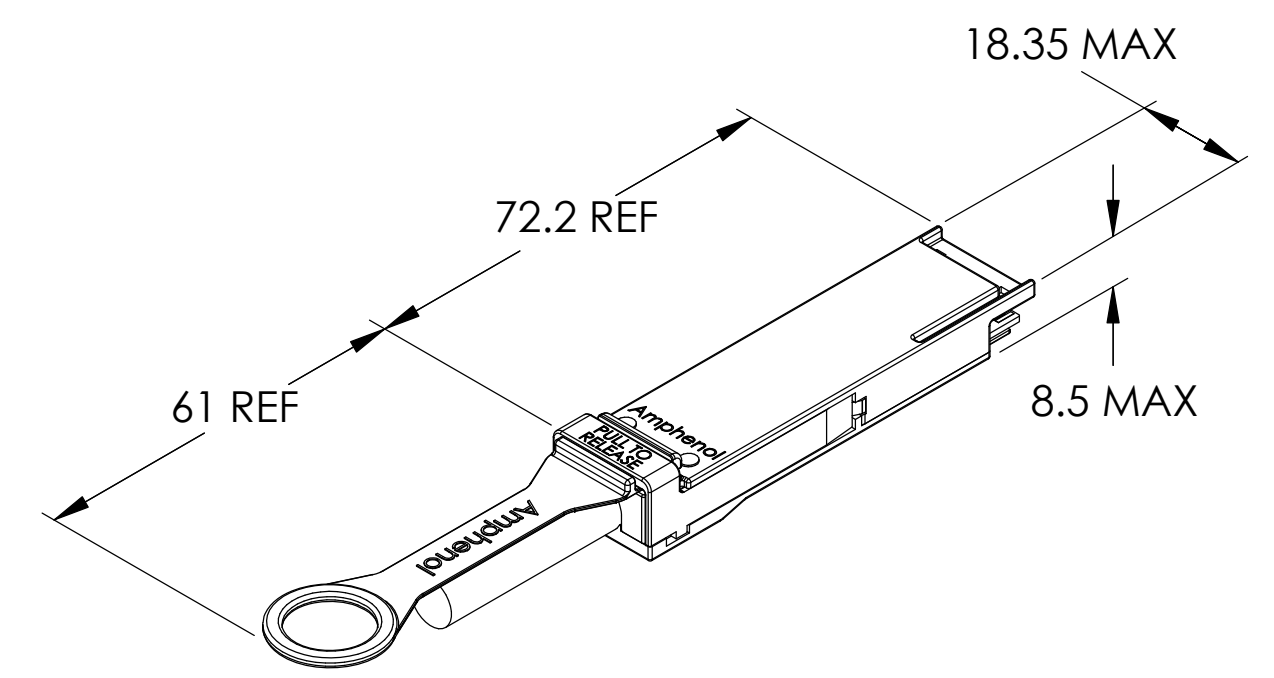
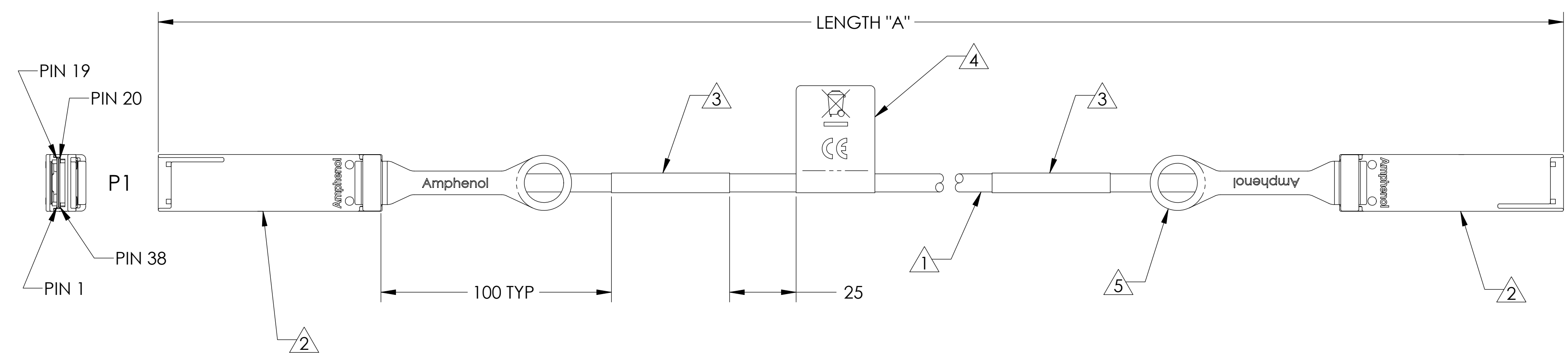

TABLE 1		
AHSP P/N	LENGTH "A" MM	CUSTOMER P/N
NDAAFJ-C102	5000 ±100	SF-NDAAFJ100G-005M
NDAAFJ-C103	2000 ± 50	SF-NDAAFJ100G-002M
NDAAFJ-C104	3000 ± 75	SF-NDAAFJ100G-003M

ZONE		REV.	SCR NUMBER	DESCRIPTION	BY	DATE	APPROVED
		A	DDYR-A3AQWW.VER01	NEW RELEASE		10/15/2015	DC
		B		ADDED 2M & 3M ASSY LENGTHS			DD



QSF DIECAST DIMENSIONS

ITEM No.	DESCRIPTION
1	26 AWG, 8-PR, PVC BLACK, 75°C CMG OR AWM STYLE 20276 80°C
2	PLUG, QSFP+, REFERENCE SFF-8661
3	LABEL, WRAPPED - AHSP P/N, REV, DATE CODE, LENGTH, CoO & SERIAL NUMBER
4	LABEL, FLAGGED - WEEE LOGO AND CE LOGO
5	LANYARD - PANTONE 347C (GREEN)
6	EPROM - REFERENCE SFF-8636, PAGE A0 ONLY

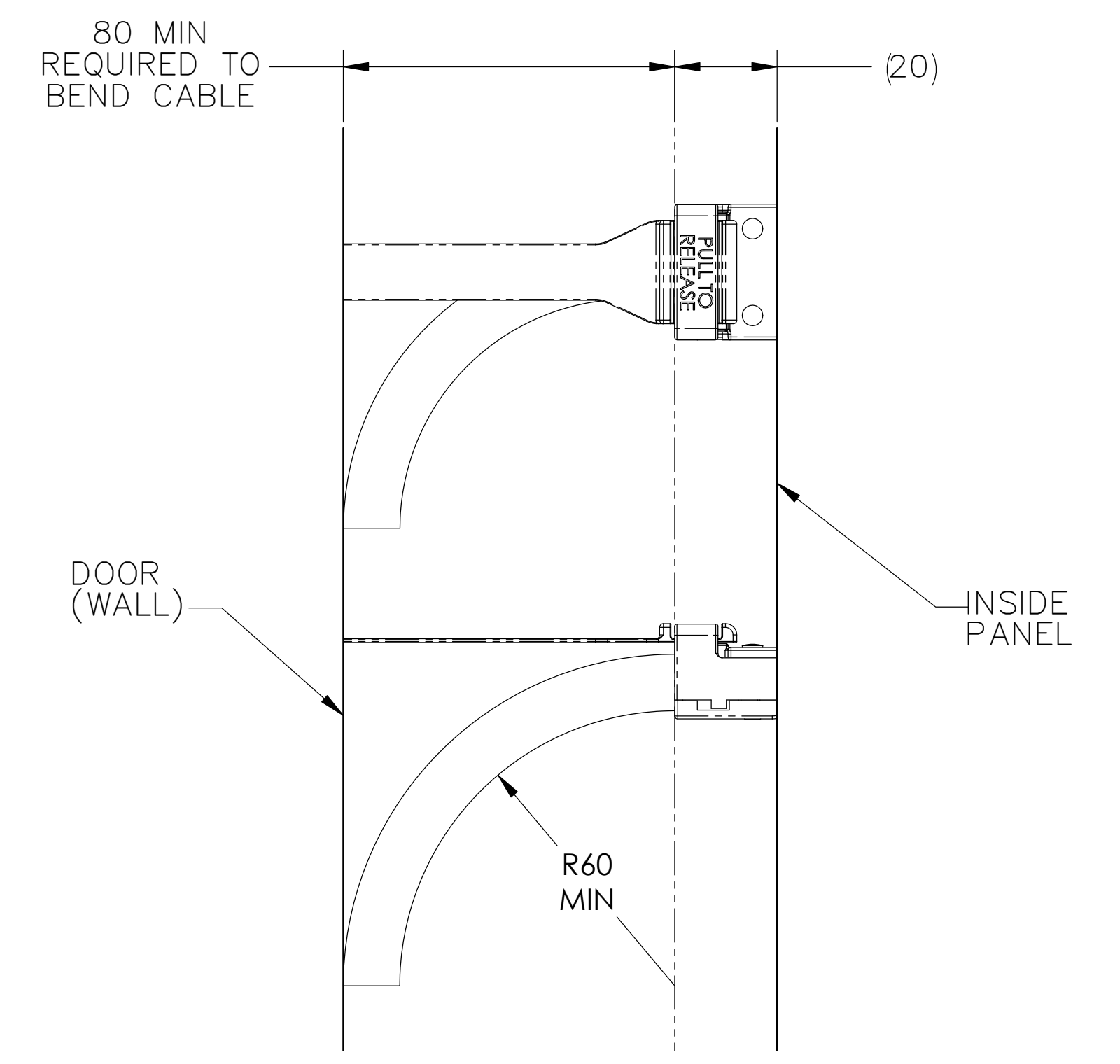
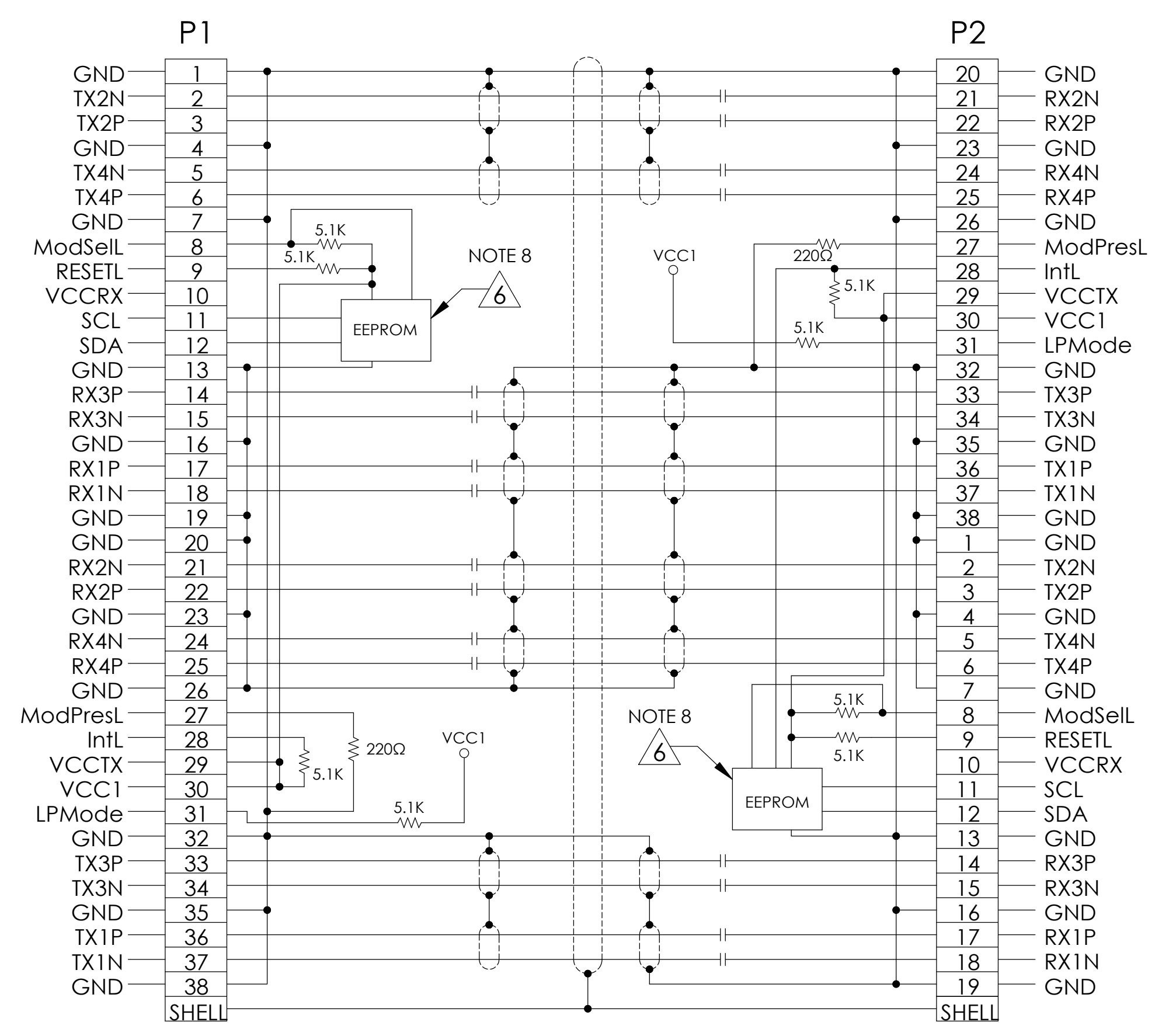

RADIUS FROM EDGE OF DIECAST

7. UL LABEL MUST BE ON THE SHIPPING CARTON PER SUBJECT 764 OF THE UL COMPONENT WIRING HARNESS (ZPFW2) FILE #E86140. CSA LABEL MUST BE ON SHIPPING CARTON.
 6. PACKAGE COMPLETED ASSY IN AN APPROPRIATELY SIZED ESD BAG.
 5. EPROM CONTENT SHALL BE COMPLIANT WITH SFF-8636 SPECIFICATIONS FOR 100G BASE-CR4. EPROM REVISION IS EQUAL TO AHSP PART NUMBER REVISION.
 4. CABLE ASSEMBLIES MUST MEET SHIELDING EFFECTIVENESS REQUIREMENTS OF 35dB FROM 1-10GHz AND 30dB FROM 10-18GHz.
 3. COMPLIANT TO EU DIRECTIVE 2011/65/EU - RoHS2.
 2. ASSEMBLIES SHALL BE COMPLIANT TO 100GBASE-CR4 SPECIFICATION.
 1. THIS DRAWING IS RESERVED FOR AMPHENOL CABLES ON DEMAND.
- NOTES: UNLESS OTHERWISE SPECIFIED

NOTE: DC BLOCKING CAP VALUE IS 0.1μ
EEPROM CONNECTED TO VCCTX

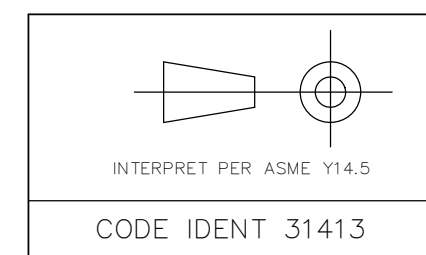
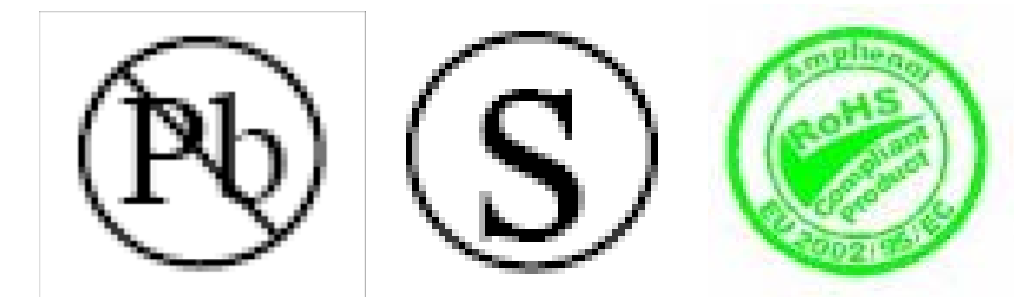

TOLERANCES	DWN	CHK	APVD	EM	TITLE
0.0	± 0.25	DC	10/13/2015	DD	Amphenol AHSP A Division of Amphenol Corporation 200 Innovative Way, Suite 201, Nashua, N.H. 03062 (603) 879-3000
0.00	± 0.08	DD	10/13/2015	DD	
		EM	10/13/2015	EM	

UNLESS OTHERWISE SPECIFIED DIMENSIONS ARE IN MM

PART NO.	SEE TABLE 3
DRAWING NO.	P-NDAAFJ-C199
SIZE	D
SCALE	1:1
SHEET	1 OF 2

TABLE 3					
AHSP P/N	AHSP REV	CUT LENGTH "A"	LABEL QUANTITY	HAND SOLDER	AUTO SOLDER
NDAAFJ-C102	A	16.437 FT	2	Y	Y
NDAAFJ-C103	A	6.594 FT	2	Y	Y
NDAAFJ-C104	A	9.879 FT	2	Y	Y

REVISIONS					
ZONE	REV.	SCR NUMBER	DESCRIPTION	BY	DATE
			SEE SHEET 1		

TABLE 4 - PARTS LIST FOR 26G ASSEMBLIES					
ITEM	AHSP P/N	AHSI P/N	COMPONENT DESCRIPTION	QUANTITY	U Of M
1	023-0010-092	1662699807	CBL RND 8PR 26 AWG SKWCLR S.S. 166-2699-807 RC	SEE CUT LENGTH 'A' IN TABLE 3	FT
2	023-Q030-042	N/A	COVER DIECAST QSFP .350 CBL RC	2	EA
3	023-Q020-140	N/A	HOUSING DIECAST QSFP .350 CBL AMPHENOL LOGO RC	2	EA
4	023-Q120-001	602480001	LATCH RELEASE DIECAST QSFP COPPER RC	2	EA
5	023-0000-054	605480001	SPRING COMPRESSION RC	4	EA
6	023-0000-052	555880001	RIVET LOW PRO MINI-SAS RC	4	EA
7	023-Q075-007	N/A	ASM PCB QSFP PASSIVE 100Gbps 26AWG RC	2	EA
8	023-0000-015	532320001	ADH HOT MELT AMBER 430F 3M 3779-PG RC UL-94V0	0.009	LB
9	527-4882-000	N/A	AHSP STANDARD CABLE LABEL	2	EA
10	023-Q080-025	587240025	LANYARD QSFP PULL TO RELEASE GRN AMPH 3.0 RC	2	EA
11	023-0000-016	24831	TAPE COPPER 1/2 CONDUCTIVE CCH-36-101-0050 RC	0.25	FT
12	023-Q130-002	613890001	DUST COVER QSFP RC	2	EA
13	023-0000-026	24848	TAPE COPPER 1-3/4 NON-CONDUCTIVE CCH-36-301-0175 RC	0.292	FT
14	527-4880-000	N/A	AHSP STANDARD CE/WEEE LABEL	1	EA
15	023-0000-056	567150001	LOCTITE UV CURE LOCTITE 3106 RC	AS NEEDED	ML
16	800-0138-107	C1518107	SHK TBG 3/8 POLY TW BLK RAYCHEM V4 3/8 BLK UL RC	0.085	FT
17	800-0122-105	C1504105	SHK TBG 1/2 POLY AW BLK TAT-125-1/2-0 RC UL	0.335	FT
18	023-0000-062	43724	KAPTON TAPE 3/4"	AS NEEDED	FT
19	527-4986-000	N/A	ACD CUST BAG LABEL	1	EA

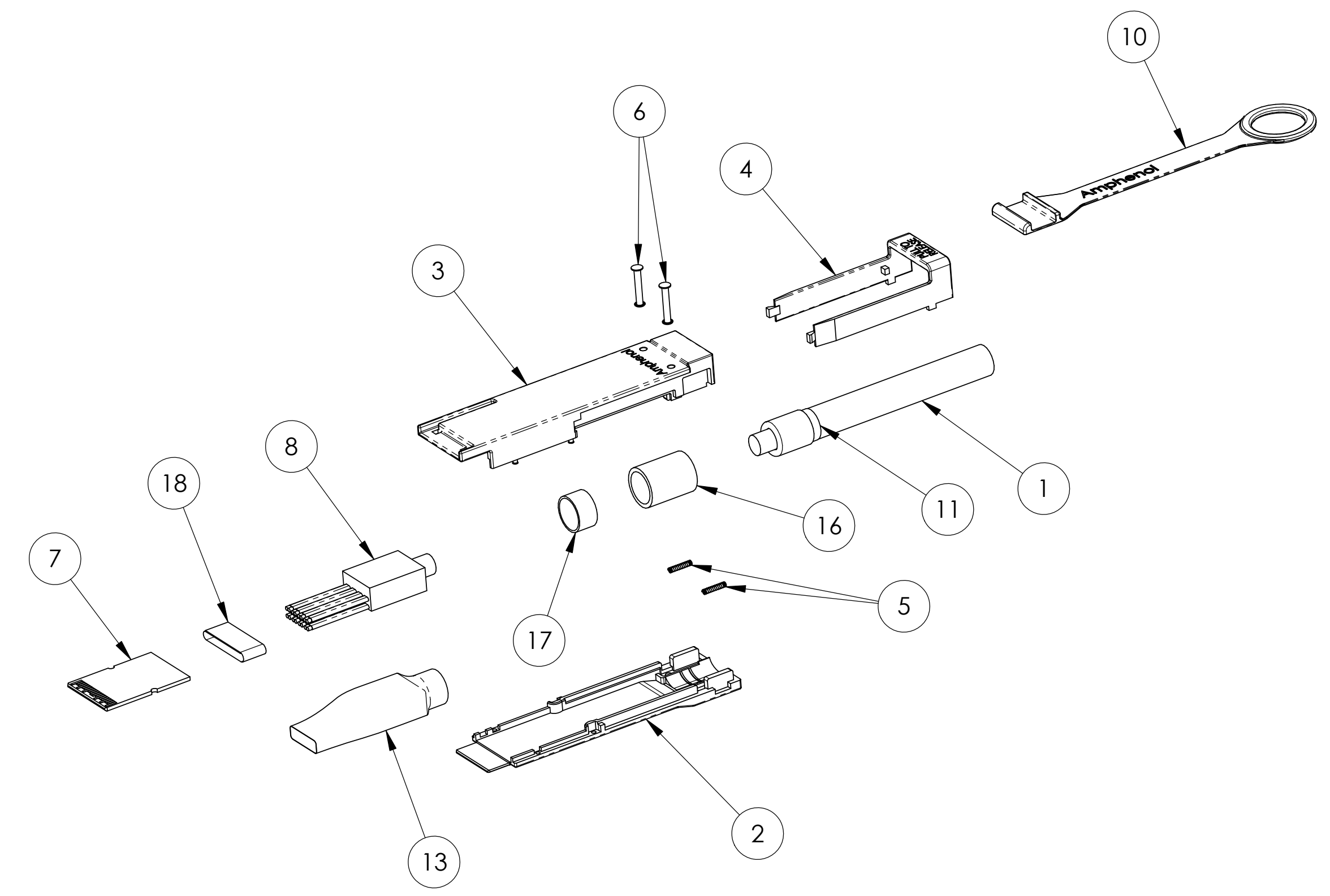

TABLE 5-AMPHENOL SPECIFICATION	
ACS-1152	AMPHENOL REGULATED MATERIALS
ACS-1154	EPROM PROGRAMMING
ACS-1186	LEAD-FREE SOLDER
ACS-1199	HIGH SPEED ASSEMBLY TEST
TMS-115-0001	CABLE ASSEMBLY MFG PROCESS
ACS-1210	STANDARD SPECIFICATIONS FOR WEEE, CHINA RoHS AND CE LABELS

TOLERANCES	DWN 10/13/2015 DC	<p>Amphenol AHSP</p> <p>A Division of Amphenol Corporation</p> <p>200 Innovative Way, Suite 201, Nashua, N.H. 03062 (603) 879-3000</p>	TITLE	CABLE ASSEMBLY, QSFP/QSFP, PSV, 100Ω, 100 GbE, 26 AWG EXD	
0.0 ± 0.25	CHK 10/13/2015 DD		PART NO.	SEE TABLE 3	
0.00 ± 0.08	APVD 10/13/2015 EM		DRAWING NO.	P-NDAAFJ-C199	
±			SIZE	D	
ANGLES	± 1.0°	UNLESS OTHERWISE SPECIFIED DIMENSIONS ARE IN MM		SCALE	1:1
<p>INTERPRET PER ASME Y14.5</p> <p>CODE IDENT 31413</p>		<p>THESE DRAWINGS AND SPECIFICATIONS ARE THE PROPERTY OF AMPHENOL CORPORATION AND SHALL NOT BE REPRODUCED OR COPIED OR USED AS THE BASIS FOR THE MANUFACTURE OR SALE OF APPARATUS WITHOUT THE WRITTEN PERMISSION OF AMPHENOL CORPORATION</p>		SHEET 2 OF 2	



Компания «ЭлектроПласт» предлагает заключение долгосрочных отношений при поставках импортных электронных компонентов на взаимовыгодных условиях!

Наши преимущества:

- Оперативные поставки широкого спектра электронных компонентов отечественного и импортного производства напрямую от производителей и с крупнейших мировых складов;
- Поставка более 17-ти миллионов наименований электронных компонентов;
- Поставка сложных, дефицитных, либо снятых с производства позиций;
- Оперативные сроки поставки под заказ (от 5 рабочих дней);
- Экспресс доставка в любую точку России;
- Техническая поддержка проекта, помощь в подборе аналогов, поставка прототипов;
- Система менеджмента качества сертифицирована по Международному стандарту ISO 9001;
- Лицензия ФСБ на осуществление работ с использованием сведений, составляющих государственную тайну;
- Поставка специализированных компонентов (Xilinx, Altera, Analog Devices, Intersil, Interpoint, Microsemi, Aeroflex, Peregrine, Syfer, Eurofarad, Texas Instrument, Miteq, Cobham, E2V, MA-COM, Hittite, Mini-Circuits, General Dynamics и др.);

Помимо этого, одним из направлений компании «ЭлектроПласт» является направление «Источники питания». Мы предлагаем Вам помощь Конструкторского отдела:

- Подбор оптимального решения, техническое обоснование при выборе компонента;
- Подбор аналогов;
- Консультации по применению компонента;
- Поставка образцов и прототипов;
- Техническая поддержка проекта;
- Защита от снятия компонента с производства.



Как с нами связаться

Телефон: 8 (812) 309 58 32 (многоканальный)

Факс: 8 (812) 320-02-42

Электронная почта: org@eplast1.ru

Адрес: 198099, г. Санкт-Петербург, ул. Калинина, дом 2, корпус 4, литера А.