



LM

SPECIFICATIONS

- **316L SS Pressure Sensor with PVC Threads**
- **Small Profile**
- **4.5V (typ) High Level Output**
- **Gage, Absolute, Sealed Gage**
- **ASIC Calibrated**
- **Variety of Cable Lengths**

The LM incorporates stainless steel and plastic isolation suitable for level sensing in water and other liquids. The LM uses a patented low cost stainless steel sensor in a PVC plastic fitting. The modular design is adaptable to an infinite number of plastic port variations. With high performance in a small form factor, the LM Series enables the miniaturization of high accuracy pressure systems. The standard output is 4.5V with a 5V supply.

FEATURES

- Threaded Process Fitting
- -20°C to +70°C Operating Temperature
- ±1% Accuracy
- ±3.0% Total Error Band
- Solid State Reliability
- Variety of Cable Lengths

APPLICATIONS

- Irrigation
- RV and Marine Holding Tank Level
- Water Storage & Recycling Systems
- Small Tank Fluid Level
- Chillers & Evaporative Coolers

STANDARD RANGES

| Range (psi) | Range (Bar) | Gage | Absolute | Sealed Gage |
|-------------|-------------|------|----------|-------------|
| 0 to 1 | 0 to .07 | • | | |
| 0 to 2 | 0 to .20 | • | | |
| 0 to 5 | 0 to .35 | • | • | • |
| 0 to 15 | 0 to 1 | • | • | • |
| 0 to 30 | 0 to 2 | • | • | • |
| 0 to 50 | 0 to 5 | • | • | • |
| 0 to 100 | 0 to 7 | • | • | • |
| 0 to 150 | 0 to 10 | • | • | • |

Note: Intermediate pressure ranges available.

PERFORMANCE SPECIFICATIONS

Supply Voltage: 5.0Vdc

Ambient Temperature: 25°C (unless otherwise specified)

| PARAMETERS | MIN | TYP | MAX | UNITS | NOTES |
|---|---|------|------|-------|-------|
| Full Scale Output | | 4.5 | | V | 1 |
| Zero Pressure Output | | 0.5 | | V | 1, 2 |
| Accuracy (combined linearity, hysteresis, & repeatability) | -1 | | +1 | %Span | 3 |
| Total Error Band (includes calibration errors above & temperature effects over the compensated range) | -3 | | +3 | %Span | |
| Supply Voltage | 4.75 | 5.00 | 5.25 | V | |
| Insulation Resistance (50Vdc) | 50 | | | MΩ | 4 |
| Pressure Overload | | | 3X | Rated | 5 |
| Pressure Burst | | | 4X | Rated | 6 |
| Compensated Temperature | 0 | | 40 | °C | |
| Operating Temperature | -20 | | +70 | °C | |
| Tightening Torque (recommended) | 1~2 Turns from Finger Tight | | | | 7 |
| Zero Offset Effect @ 1psiG from 90° Changes due to Installation Orientation | | 0.6 | | %Span | 8 |
| Media, Pressure Port | Liquids and Gases compatible with PVC, 316/316L ST STL, Buna-N O-Ring | | | | |

Notes

1. Ratiometric to supply voltage.
2. Measured at vacuum for Absolute (A), ambient for Gage (G) and Sealed Gage (S).
3. Best fit straight line.
4. Minimum from any wire to metal diaphragm.
5. The maximum pressure that can be applied without changing the transducer's performance or accuracy
6. The maximum pressure that can be applied to a transducer without rupture of either the sensing element or transducer.
7. Over-torquing will damage the PVC fitting and will cause sensor calibration and/or zero offset to shift during installation. Always check for a zero offset shift after installing.
8. Zero offset effect is inversely ratiometric to pressure range, for 2psiG: 0.3% Span (typ); for 5psiG: 0.12% Span (typ).

Additional Notes

9. Standard gage units are not recommended for vacuum applications.
10. Direct mechanical contact with diaphragm is prohibited. Diaphragm surface must remain free of defects (scratches, punctures, dents, fingerprints, etc.) for device to operate properly. Caution is advised when handling parts with exposed diaphragms. Use protective cap whenever devices are not in use.

DIMENSIONS

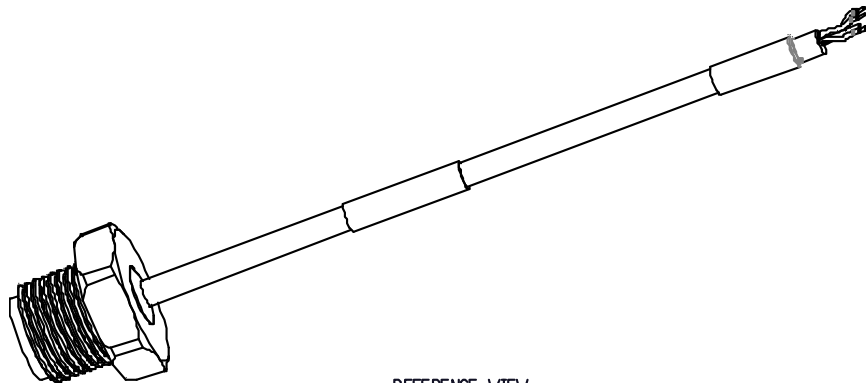
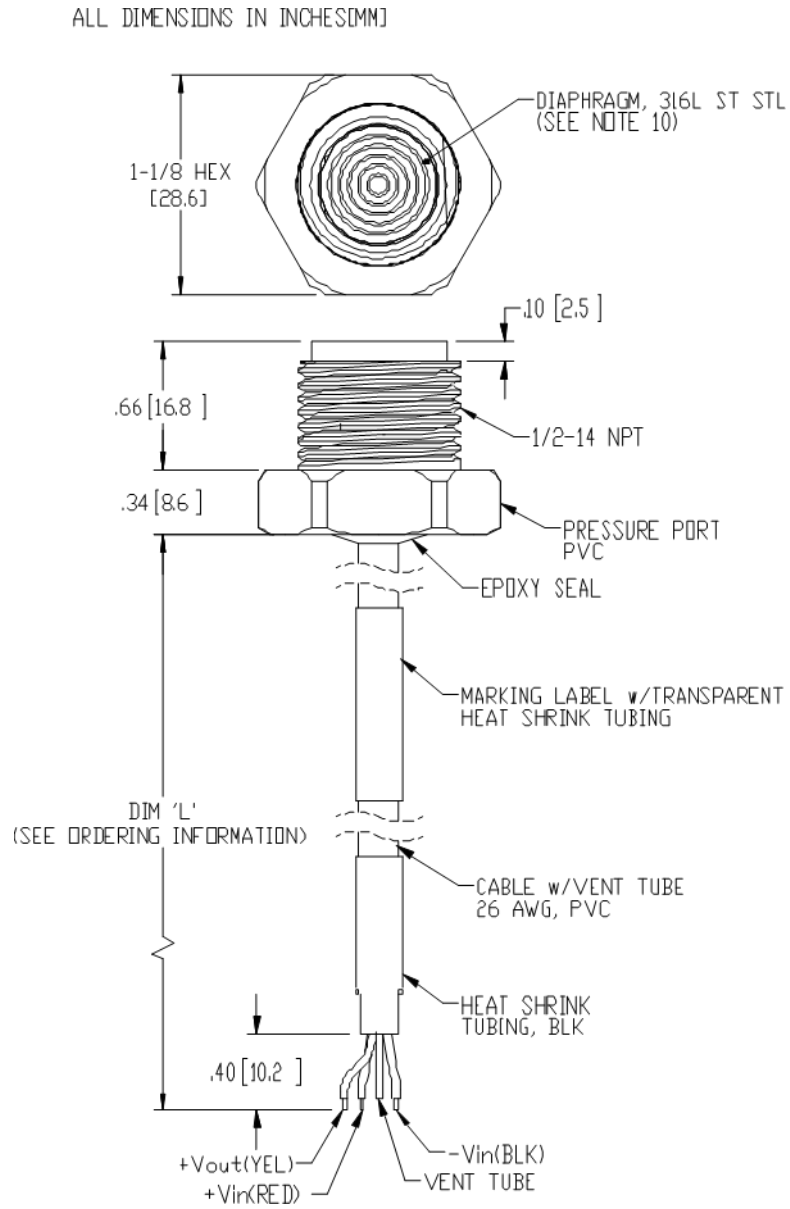

ORDERING INFORMATION

| | | | | | | | | | |
|--------------|---|---|---|--------------|---|---|--|--|--|
| LM | 3 | 1 | - | 00000 | F | - | 100P | G | |
| Model | Output Signal | Connection Type | - | 00000 | Pressure Port | - | Pressure Range | Pressure Type | |
| LM | 3* = 0.5 – 4.5V Ratiometric X = Special | Dim 'L' Cable Inches [mm] 1 = 12 ± 0.25 [305 ± 6.4] 2 = 24 ± 0.5 [610 ± 12.7] 3 = 48 ± 1.0 [1219 ± 25.4] 4 = 84 ± 1.5 [2134 ± 38.1] 5 = 120 ± 1.5 [3048 ± 38.1] 6 = 180 ± 2.0 [4572 ± 50.8] 7 = 360 ± 2.0 [9144 ± 50.8] | - | 00000 | F = 1/2-14 NPT X = Special | - | 001P** 002P** 005P 015P 030P 050P 100P 150P | .07B** .20B** .35B 001B 002B 005B 007B 010B | G = Gage A = Absolute S = Sealed Gage |

*Note: Ratiometric output span changes with input voltage. (See supply voltage specification)

**Note: 1psi (.07Bar) and 2psi (.20Bar) only available in Gage (G). (See standard rages)

NORTH AMERICA

Measurement Specialties, Inc.,
a TE Connectivity Company
45738 Northport Loop West
Fremont, CA 94538
Tel: 1-800-767-1888
Fax: 1-510-498-1578
Sales: pfg.cs.amer@meas-spec.com

EUROPE

Measurement Specialties (Europe), Ltd.,
a TE Connectivity Company
26 Rue des Dames
78340 Les Clayes-sous-Bois, France
Tel: +33 (0) 130 79 33 00
Fax: +33 (0) 134 81 03 59
Sales: pfg.cs.emea@meas-spec.com

ASIA

Measurement Specialties (China), Ltd.,
a TE Connectivity Company
No. 26 Langshan Road
Shenzhen High-Tech Park (North)
Nanshan District, Shenzhen 518057
China
Tel: +86 755 3330 5088
Fax: +86 755 3330 5099
Sales: pfg.cs.asia@meas-spec.com

TE.com/sensorsolutions

Measurement Specialties, Inc., a TE Connectivity company.

Measurement Specialties, TE Connectivity, TE Connectivity (logo) and EVERY CONNECTION COUNTS are trademarks. All other logos, products and/or company names referred to herein might be trademarks of their respective owners.

The information given herein, including drawings, illustrations and schematics which are intended for illustration purposes only, is believed to be reliable. However, TE Connectivity makes no warranties as to its accuracy or completeness and disclaims any liability in connection with its use. TE Connectivity's obligations shall only be as set forth in TE Connectivity's Standard Terms and Conditions of Sale for this product and in no case will TE Connectivity be liable for any incidental, indirect or consequential damages arising out of the sale, resale, use or misuse of the product. Users of TE Connectivity products should make their own evaluation to determine the suitability of each such product for the specific application.

© 2015 TE Connectivity Ltd. family of companies All Rights Reserved.



Компания «ЭлектроПласт» предлагает заключение долгосрочных отношений при поставках импортных электронных компонентов на взаимовыгодных условиях!

Наши преимущества:

- Оперативные поставки широкого спектра электронных компонентов отечественного и импортного производства напрямую от производителей и с крупнейших мировых складов;
- Поставка более 17-ти миллионов наименований электронных компонентов;
- Поставка сложных, дефицитных, либо снятых с производства позиций;
- Оперативные сроки поставки под заказ (от 5 рабочих дней);
- Экспресс доставка в любую точку России;
- Техническая поддержка проекта, помощь в подборе аналогов, поставка прототипов;
- Система менеджмента качества сертифицирована по Международному стандарту ISO 9001;
- Лицензия ФСБ на осуществление работ с использованием сведений, составляющих государственную тайну;
- Поставка специализированных компонентов (Xilinx, Altera, Analog Devices, Intersil, Interpoint, Microsemi, Aeroflex, Peregrine, Syfer, Eurofarad, Texas Instrument, Miteq, Cobham, E2V, MA-COM, Hittite, Mini-Circuits, General Dynamics и др.);

Помимо этого, одним из направлений компании «ЭлектроПласт» является направление «Источники питания». Мы предлагаем Вам помощь Конструкторского отдела:

- Подбор оптимального решения, техническое обоснование при выборе компонента;
- Подбор аналогов;
- Консультации по применению компонента;
- Поставка образцов и прототипов;
- Техническая поддержка проекта;
- Защита от снятия компонента с производства.



Как с нами связаться

Телефон: 8 (812) 309 58 32 (многоканальный)

Факс: 8 (812) 320-02-42

Электронная почта: org@eplast1.ru

Адрес: 198099, г. Санкт-Петербург, ул. Калинина, дом 2, корпус 4, литера А.