



A New Direction in Mixed-Signal

February 2013

# XRP7618 8-Channel Constant Current Linear LED Driver With Smart Talk™

Rev. 1.2.0

## GENERAL DESCRIPTION

The XRP7618 is an 8-channel, high voltage, constant-current sink LED driver capable of driving up to 100mA current per channel. With outputs rated at 30V, the XRP7618 can control strings of multiple LEDs with better than  $\pm 1.5\%$  channel to channel current matching.

LED channel current is programmed via an external resistor within a 10mA to 100mA range. Dimming control is supported through a standard PWM scheme up to 25kHz or through an analog signal.

Featuring Exar's Smart Talk™ technology, when combined with a boost converter, the XRP7618 maximizes the overall system efficiency by dynamically reporting the minimum LED voltage necessary to maintain current regulation mode. Multiple channels can be combined to increase current driving capability per channel and multiple XRP7618s can be placed in parallel to drive over 8 strings of LEDs.

An under voltage lock out, open LED and over temperature protections insure safe operations under abnormal operating conditions.

The XRP7618 is available in RoHS compliant, "green"/halogen free space saving 20-pin TSSOP (EP) package.

## APPLICATIONS

- LCD Backlighting
- Desktop, Notebook and TV Displays
- Industrial and Medical Displays
- Signage Backlighting

## FEATURES

- **8 Constant-Current Channels**
  - Adjustable up to 100mA per Channel
  - Channel Paralleling for higher Current
  - $\pm 1.5\%$  Current Matching Accuracy
- **Up to 30V LED Channel Voltage Range**
  - 5V Biasing Voltage and Control
- **Smart Talk™ Power Optimization**
- **Parallel Operations Support**
- **PWM and Analog Dimming**
- **UVLO, Open LED & Over Temperature protection**
- **RoHS Compliant Halogen Free, 20-pin TSSOP (EP) Package**

## TYPICAL APPLICATION DIAGRAM

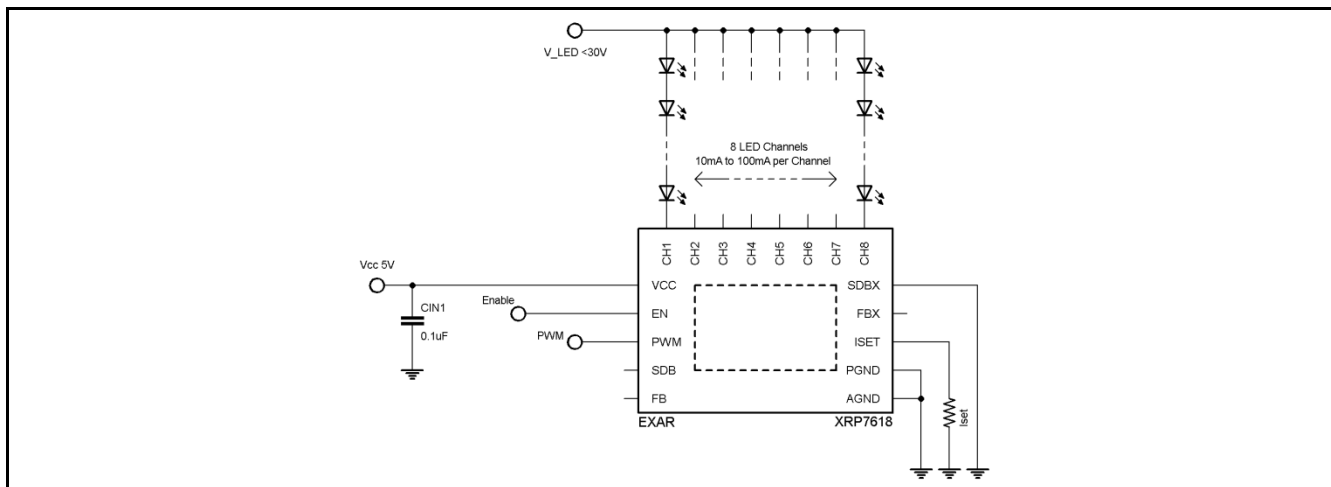

Fig. 1: XRP7618 Typical Application Diagram

### ABSOLUTE MAXIMUM RATINGS

These are stress ratings only and functional operation of the device at these ratings or any other above those indicated in the operation sections of the specifications below is not implied. Exposure to absolute maximum rating conditions for extended periods of time may affect reliability.

V <sub>CC</sub> , ISET, EN, FB, SDB, PWM	-0.3V to 6.0V
CHx	-0.3V to 30V
Junction Temperature	150°C
Storage Temperature	-65°C to 150°C
Power Dissipation	Internally Limited
Lead Temperature (Soldering, 10 sec)	260°C
ESD Rating (HBM - Human Body Model)	6kV
ESD Rating (MM - Machine Model)	200V

### OPERATING RATINGS

Input Voltage Range V <sub>CC</sub>	4.2V to 5.5V
PWM Dimming Frequency	0.1KHz to 25KHz
Current per Channel	
V <sub>CHx</sub> ≥ 0.5V	10mA to 25mA
V <sub>CHx</sub> ≥ 1V	10mA to 65mA
V <sub>CHx</sub> ≥ 1.5V	10mA to 110mA
Operating Temperature Range	-40°C to 85°C
Thermal Resistance θ <sub>JA</sub> (TSSOP-20) <sup>1</sup>	35°C/W

Note 1: The device is soldered to a 60mm<sup>2</sup> plane of copper (4mm × 15mm - top side solder mask) of 1oz. on a PCB with 8 × 0.5mm vias.

### ELECTRICAL SPECIFICATIONS

Specifications with standard type are for an Operating Junction Temperature of T<sub>J</sub> = 25°C only. Minimum and Maximum limits are guaranteed through test, design, or statistical correlation. Typical values represent the most likely parametric norm at T<sub>J</sub> = 25°C, and are provided for reference purposes only. Unless otherwise indicated, V<sub>CC</sub> = 5V, R<sub>ISET</sub> = 8.2kΩ, T<sub>A</sub> = 25°C.

Parameter	Min.	Typ.	Max.	Units	Conditions
Operating Input Voltage Range V <sub>CC</sub>	4.2	5.0	5.5	V	
Shutdown Supply Current		0.1	1	µA	V <sub>EN</sub> =0V
Quiescent Supply Current		0.5	1	mA	No load
Under Voltage Lockout threshold	3.6	3.8	4.0	V	Falling edge
Under Voltage Lockout Hysteresis		200		mV	
ISET Reference Voltage	1.170	1.194	1.218	V	
Current Multiplication Ratio	370	400	430		I <sub>CHX</sub> /I <sub>ISET</sub>
Maximum Output Current per Channel	23	45		mA	V <sub>CHX</sub> =0.5V
	65	70			V <sub>CHX</sub> =1.0V
	110	120			V <sub>CHX</sub> =1.5V
LED Current Matching	-1.5		1.5	%	Any 2 channels V <sub>CHX</sub> =1.0V, I <sub>CHX</sub> =60mA
Current Sink Saturation Voltage			0.45	V	I <sub>CHX</sub> =20mA
			0.8		I <sub>CHX</sub> =60mA
			1.2		I <sub>CHX</sub> =100mA
Output Current Line Regulation			2	%/V	V <sub>CC</sub> =4.2V to 5.5V
Output Current Load Regulation			4	%	V <sub>CHX</sub> =0.5V to 2.8V
Enable Logic LOW			0.8	V	XRP7618 is disabled
Enable Logic HIGH	1.8			V	XRP7618 is active
PWM Pin Logic LOW			0.8	V	XRP7618 is disabled
PWM Pin Logic HIGH	1.8			V	XRP7618 is active
SDB Pin Logic LOW			0.4	V	
SDB Pin Logic HIGH	2.4			V	
Feedback Output Current	5	15		µA	
Thermal Shutdown Die Temperature		160		°C	
Thermal Shutdown Hysteresis		20		°C	

### BLOCK DIAGRAM

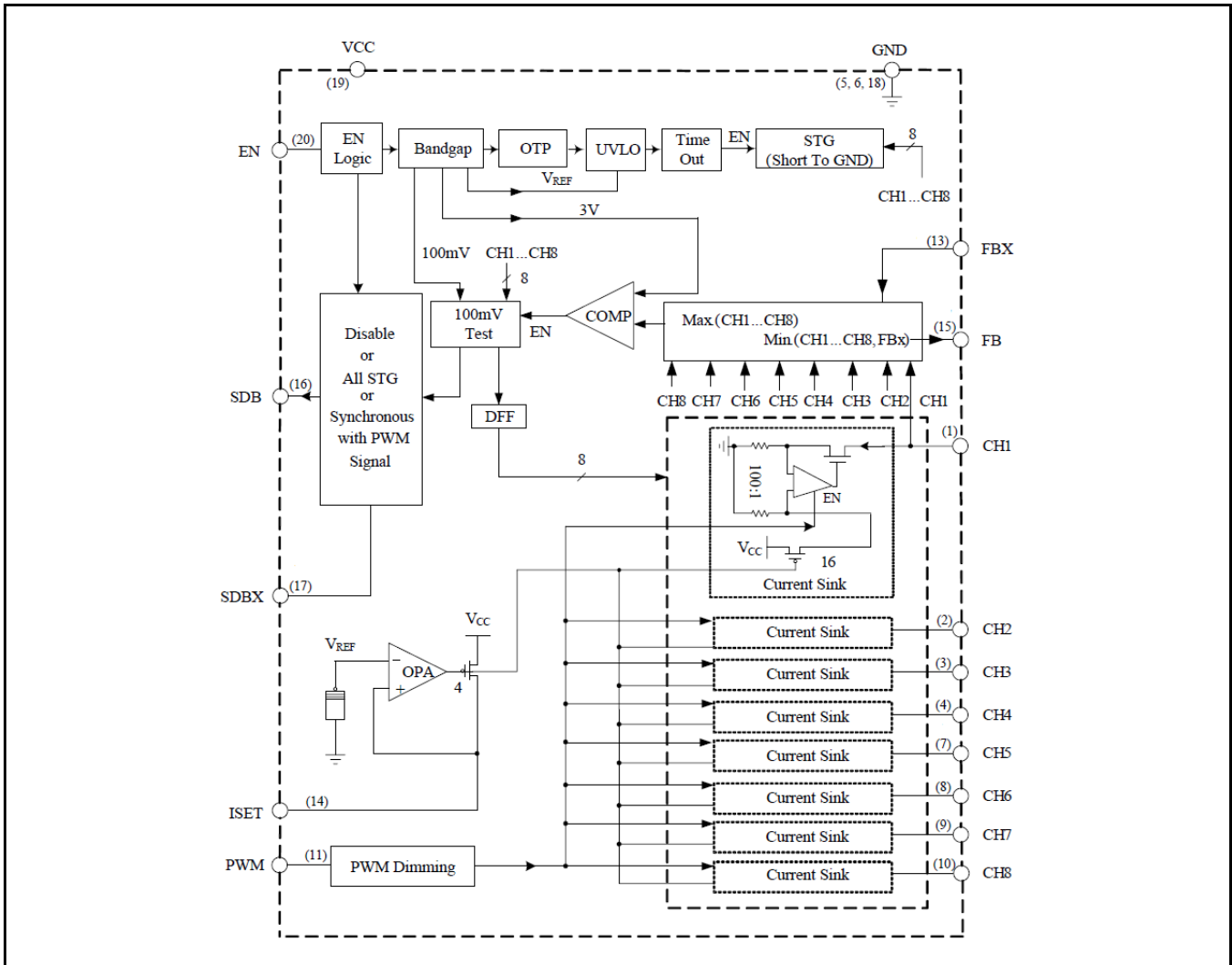

Fig. 2: XRP7618 Block Diagram

### PIN ASSIGNMENT

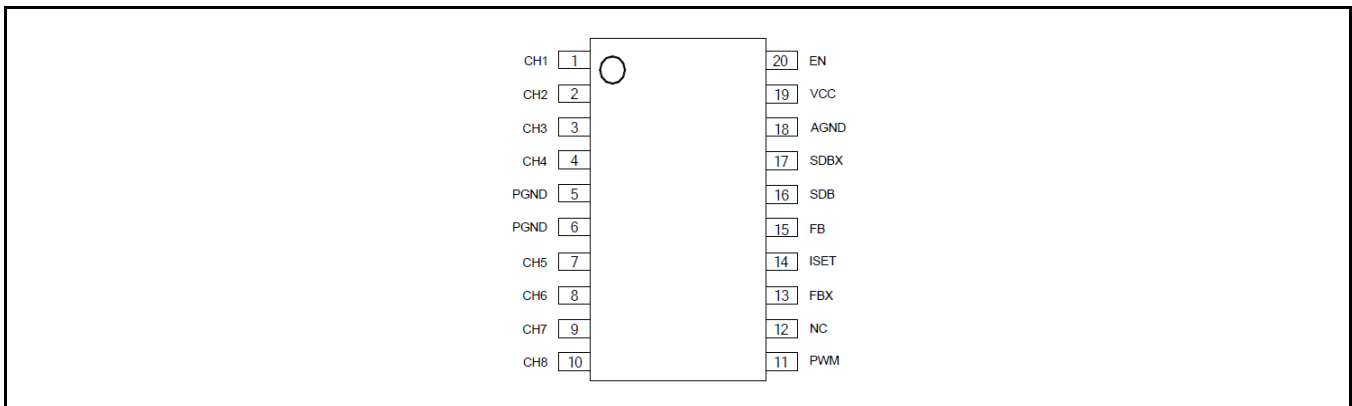

Fig. 3: XRP7618 Pin Assignment

### PIN DESCRIPTION

Name	Pin Number	Description
CHx	1, 2, 3, 4, 7, 8, 9, 10	CH1 to CH8 pins Connect an LED between each pin and LED supply rail voltage ( $V_{LED}$ ). Current value is controlled by $R_{SET}$ . Connect unused channel(s) to GND.
NC	12	Not Connected
PWM	11	PWM pin This must be held HIGH to enable the output drivers. It can be used for PWM dimming up to 25kHz. If not used, connect to $V_{CC}$ .
FBX	13	FBX input pin Used in parallel configuration as an interface terminal by connecting it to FB pin of the next XRP7618. If not used, leave it unconnected.
ISET	14	ISET pin Connect resistor $R_{SET}$ from this pin to ground to set LED channel current as per $I_{CHANNEL} = 1.194 \times 400 / R_{SET}$
FB	15	FB pin Samples the LED cathode voltage on each channel and outputs the lowest voltage to the step-up converter.
SDB	16	SDB output pin SDB signal is synchronous with the PWM signal during PWM Dimming. It outputs low logic to the step-up converter under conditions such as shutdown or when all channels are inactive.
SDBX	17	SDBX input pin Used in parallel configuration as an interface terminal by connecting it to SDB pin of the next XRP7618. If not used, connect it to GND.
AGND	18	Ground pin
VCC	19	Input Voltage pin Must be closely decoupled to GND pin with a 0.1 $\mu$ F ceramic capacitor.
EN	20	Enable pin This pin must be held HIGH to enable the XRP7618.
PGND	5, 6	Ground pin
EP	Exposed Pad	Exposed Pad Connect to ground

### ORDERING INFORMATION

Part Number	Temperature Range	Marking	Package	Packing Quantity	Note 1	Note 2
XRP7618IGB-F	-40°C ≤ T <sub>A</sub> ≤ +85°C	EXAR XRP7618IGB YYWWF XXXX	TSSOP-20	Bulk	Halogen Free RoHS Compliant	Exposed Pad
XRP7618IGBTR-F				1.5K/Tape & Reel		
XRP7618EVB	XRP7618 Evaluation Board					

“YY” = Year – “WW” = Work Week – “X” = Lot Number, when applicable.

### TYPICAL PERFORMANCE CHARACTERISTICS

All data taken at  $V_{CC} = 5V$ ,  $R_{ISET} = 8k\Omega$ ,  $T_A = 25^\circ C$ , unless otherwise specified - Schematic and BOM from Application Information section of this datasheet.

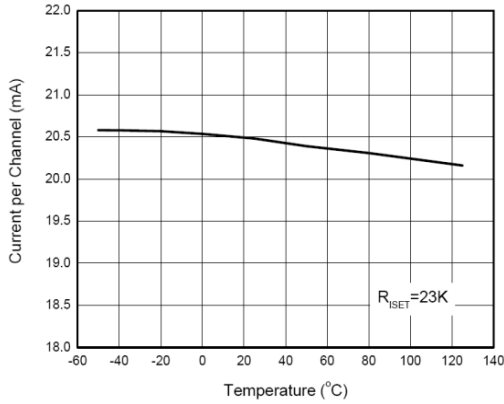

Fig. 4: Current per Channel vs Temperature

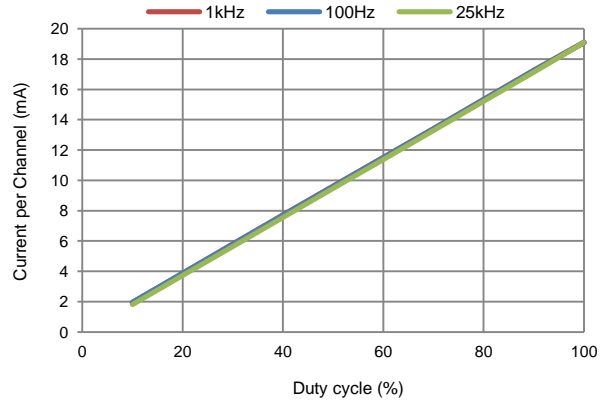

Fig. 5: PWM Dimming: Current per Channel vs Duty Cycle

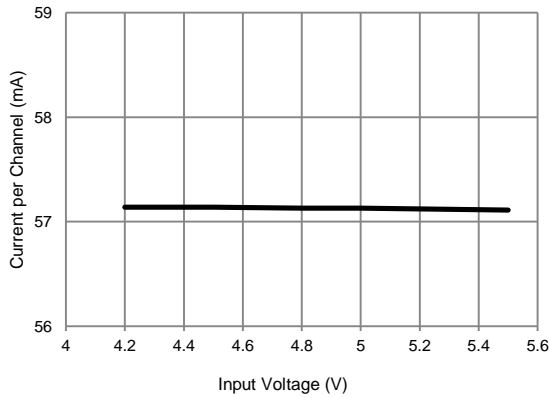

Fig. 6: Current per Channel vs Input Voltage

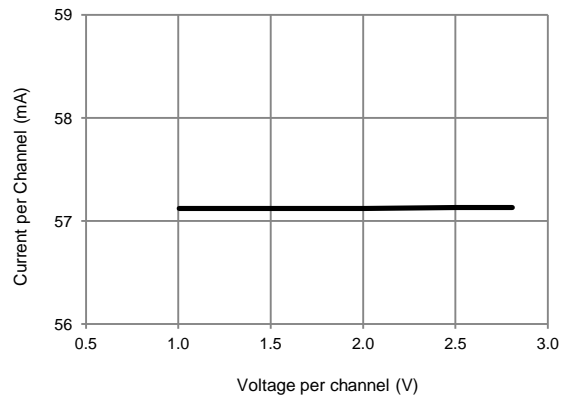

Fig. 7: Current per Channel vs Voltage per Channel

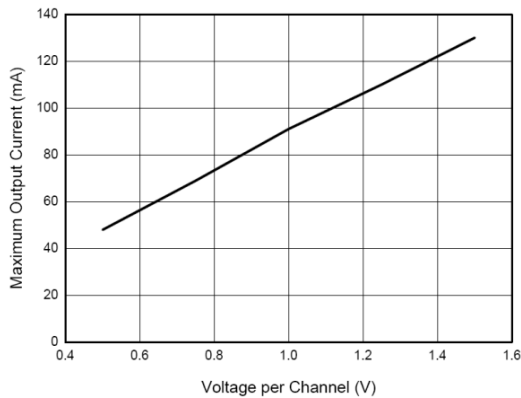

Fig. 8: Maximum Output Current vs Voltage per Channel

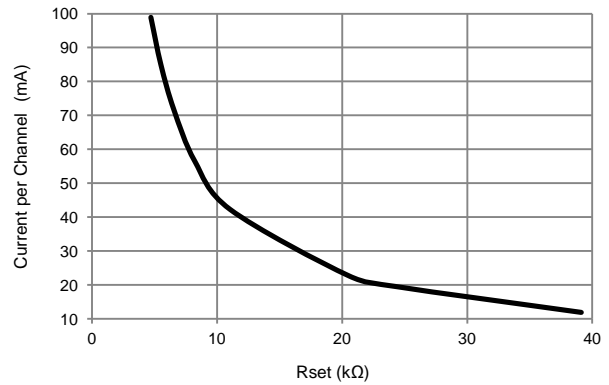

Fig. 9: Current per Channel vs RSET resistor

### THEORY OF OPERATION

The XRP7618 is an eight channel programmable constant current LED driver capable of up to 100mA per channel. A single external resistor adjusts the current for each channel over a 10mA to 100mA range with tight matching between channels.

Dimming is supported through a standard PWM scheme or through an analog signal. Furthermore, the XRP7618 maximizes the overall system efficiency by dynamically reporting the minimum LED voltage necessary to remain in current regulation mode when used with a boost converter.

Multiple XRP7618s can be placed in parallel to drive over 8 strings of LEDs; however, unused channels should be tied to ground.

Built-in under voltage lock out, open LED and over temperature protections insure safe operations under abnormal operating conditions.

### LED CHANNELS CURRENT SETTING

The maximum LED current can be set up to 100mA per channel through the ISET pin. To set the reference current  $I_{SET}$ , connect a resistor  $R_{SET}$  between this pin and ground. The value of  $R_{SET}$  can be calculated by the following formula:

$$I_{SET} = \frac{1.194V}{R_{SET}}$$

This reference current is multiplied internally with a gain (K) of 400 then mirrored on all enabled channels. This sets the maximum LED current, referred to as 100% current ( $I_{LEDMAX}$ ). The value can be calculated by the following formula:

$$I_{LEDMAX} = K \times I_{SET}$$

or,

$$R_{SET} = \frac{K \times 1.194V}{I_{LEDMAX}} = \frac{400 \times 1.194V}{I_{LEDMAX}}$$

The LED current can be reduced from 100% by PWM dimming control.

### PWM DIMMING CONTROL

The LED current can be adjusted by applying a PWM signal to the PWM pin. In this mode, all enabled channels are adjusted at the same time and brightness is adjusted from 1% to 100% of  $I_{LEDMAX}$ .

The supported external PWM signal frequency is 100Hz to 25kHz.

### ANALOG DIMMING CONTROL

Besides PWM dimming control, the LED current can be controlled continuously (from highest to lowest LED current) by raising the voltage at the bottom of RSET from 0V normally to 1V max, respectively. RSET value may be determined as

$$R_{SET} = \frac{(1.194 - V_{MOD}) \times 400}{I_{LEDMAX}}$$

where, 1.194V is a typical ISET pin voltage,  $V_{MOD}$  is an adjustment voltage applied to the bottom side of RSET, 400 is the typical current multiplication ratio, and  $I_{LEDMAX}$  is the required LED current per channel.

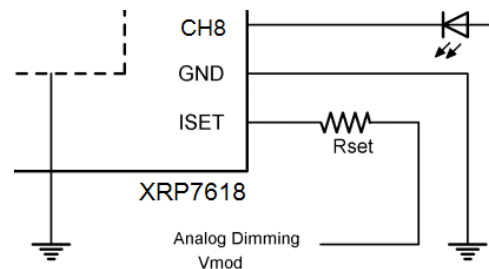

Fig. 10: XRP7618 Analog Dimming Control

If adjustment voltage  $V_{MOD}$  isn't used, RSET resistor should be connected to ground.

### SYSTEM POWER OPTIMIZATION

The Smart Talk feature enables XRP7618 to maximize the overall system power efficiency, when used with a step-up converter, by dynamically reporting the minimum LED channel voltage needed to maintain current regulation mode. The XRP7618 samples the voltage on each channel input and reports the lowest voltage of all strings via the FB signal to the associated step up converter.

If placed in shutdown through the EN pin or if all channels are inactive, the XRP7618 outputs

a logic low to the converter via the SDB signal. Furthermore, the SDB signal is synchronous to the PWM signal when PWM dimming is used.

### OPEN LED PROTECTION

The XRP7618 provides a built-in protection for open LED channel. Upon detection of an open LED channel event, the FB signal is driven low to allow the step-up converter to operate open loop which in turn raises the voltage on the remaining CHx pins. Upon reaching an internally pre-set threshold of 3V, the XRP7618 identifies the faulty channel and removes it from the control and reporting loop. At this point the FB signal resumes its normal function of reporting the lowest LED channel voltage and hence restores the proper operations of the converter. Note that the open LED channel is not disabled; however, its

CHx voltage is no longer reported. Upon reconnection of the open LED channel, current will be driven at the programmed level.

### PARALLEL MODE OF OPERATION

Multiple XRP7618s can be placed in parallel to drive over 8 strings of LEDs; however, unused channels should be tied to ground.

While the initial XRP7618 is connected to the step-up converter via its FB and SDB pins, the daisy chained XRP7618s are connected to each other through the respective FBX and SDBX pins. In this configuration, the initial XRP7618 reports the lowest LED voltage and SDB signal of all the XRP7618s in parallel. Refer to figure 12.

## TYPICAL APPLICATION SCHEMATICS

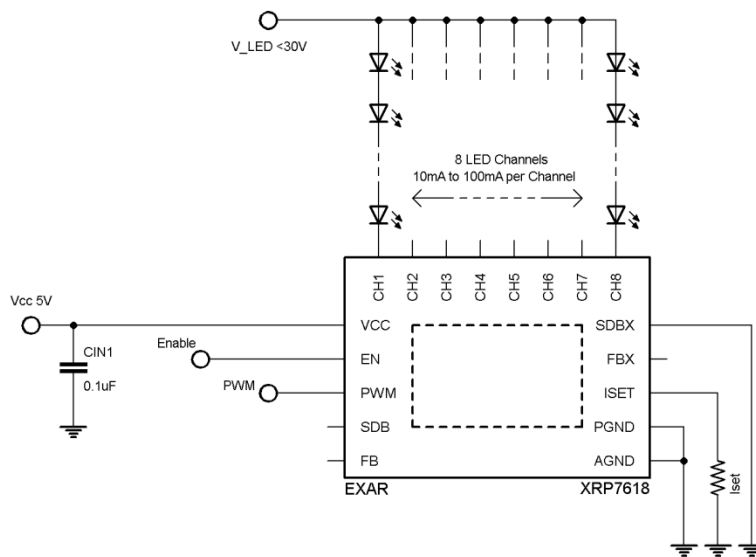

Fig. 11: Single XRP7618 Application

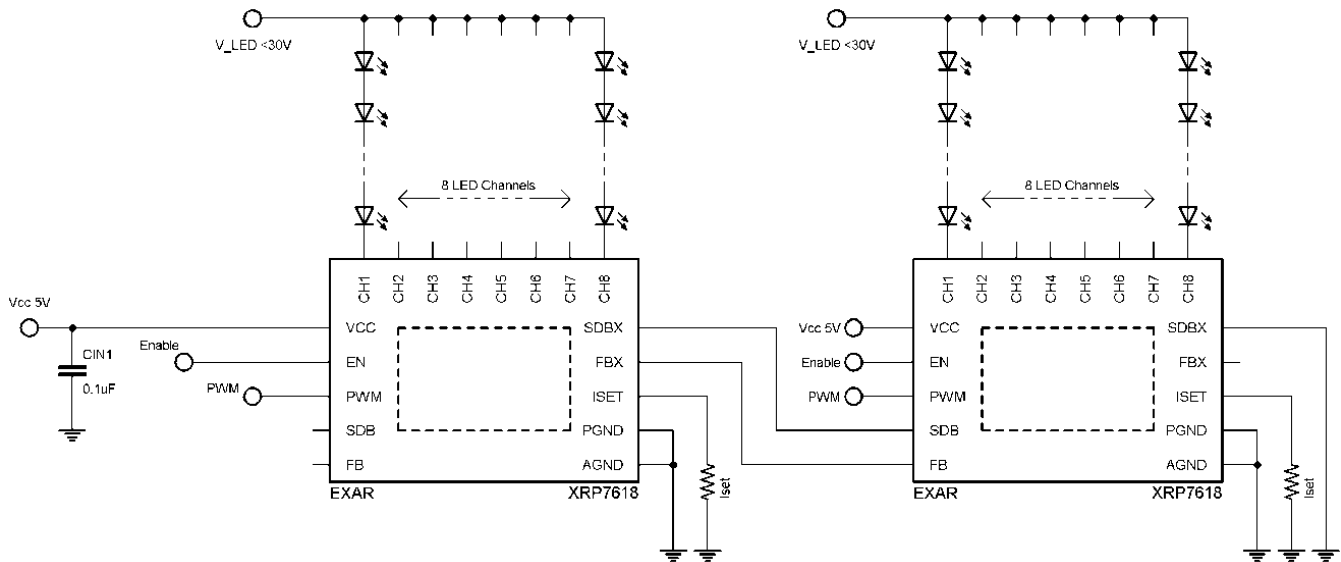

Fig. 12: Parallel Operations with the XRP7618

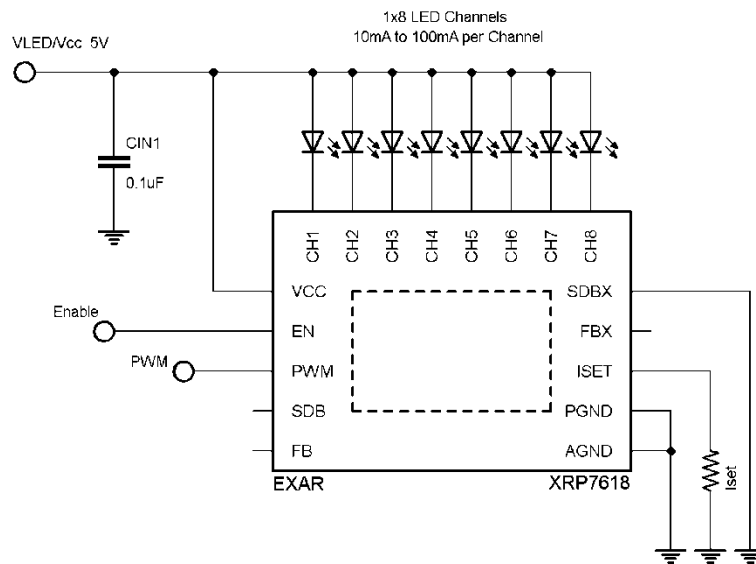

Fig. 13: Single Supply Operations with the XRP7618





A New Direction in Mixed-Signal

# XRP7618 8-Channel Constant Current Linear LED Driver With Smart Talk™

## PACKAGE SPECIFICATION

### 20-PIN TSSOP (EXPOSED PAD)

Unit: mm (inch)

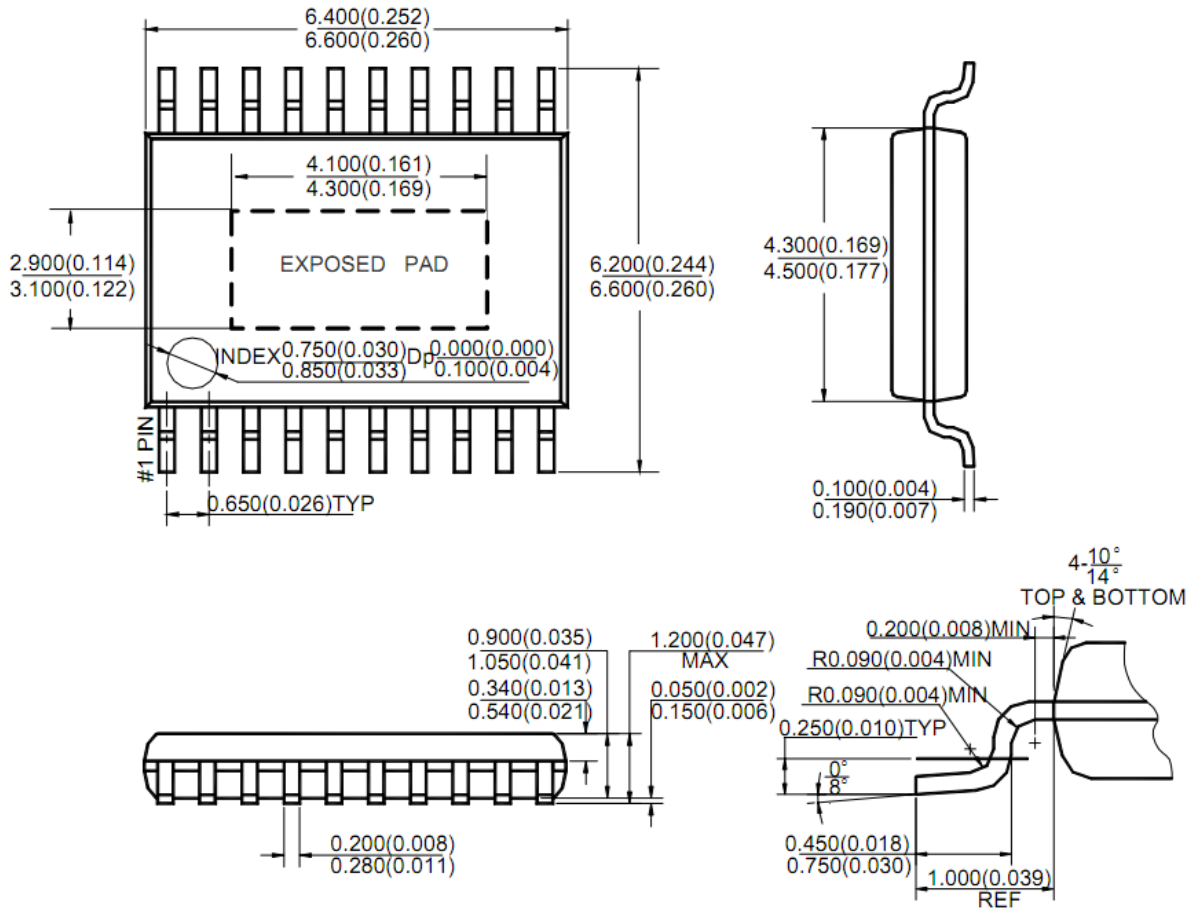

Note: Eject hole, oriented hole and mold mark is optional.

**REVISION HISTORY**

Revision	Date	Description
1.0.0	07/26/2011	Initial Release of datasheet
1.1.0	08/24/2012	Corrected package drawings
1.2.0	02/12/2013	Addition of Note 1, package thermal performance under Operating Ratings section

**FOR FURTHER ASSISTANCE**

Email:

[customersupport@exar.com](mailto:customersupport@exar.com)

[powertechsupport@exar.com](mailto:powertechsupport@exar.com)

Exar Technical Documentation:

<http://www.exar.com/TechDoc/default.aspx?>



**EXAR CORPORATION**

**HEADQUARTERS AND SALES OFFICES**

48720 Kato Road

Fremont, CA 94538 – USA

Tel.: +1 (510) 668-7000

Fax: +1 (510) 668-7030

[www.exar.com](http://www.exar.com)

**NOTICE**

EXAR Corporation reserves the right to make changes to the products contained in this publication in order to improve design, performance or reliability. EXAR Corporation assumes no responsibility for the use of any circuits described herein, conveys no license under any patent or other right, and makes no representation that the circuits are free of patent infringement. Charts and schedules contained herein are only for illustration purposes and may vary depending upon a user's specific application. While the information in this publication has been carefully checked; no responsibility, however, is assumed for inaccuracies.

EXAR Corporation does not recommend the use of any of its products in life support applications where the failure or malfunction of the product can reasonably be expected to cause failure of the life support system or to significantly affect its safety or effectiveness. Products are not authorized for use in such applications unless EXAR Corporation receives, in writing, assurances to its satisfaction that: (a) the risk of injury or damage has been minimized; (b) the user assumes all such risks; (c) potential liability of EXAR Corporation is adequately protected under the circumstances.

Reproduction, in part or whole, without the prior written consent of EXAR Corporation is prohibited.



Компания «ЭлектроПласт» предлагает заключение долгосрочных отношений при поставках импортных электронных компонентов на взаимовыгодных условиях!

Наши преимущества:

- Оперативные поставки широкого спектра электронных компонентов отечественного и импортного производства напрямую от производителей и с крупнейших мировых складов;
- Поставка более 17-ти миллионов наименований электронных компонентов;
- Поставка сложных, дефицитных, либо снятых с производства позиций;
- Оперативные сроки поставки под заказ (от 5 рабочих дней);
- Экспресс доставка в любую точку России;
- Техническая поддержка проекта, помощь в подборе аналогов, поставка прототипов;
- Система менеджмента качества сертифицирована по Международному стандарту ISO 9001;
- Лицензия ФСБ на осуществление работ с использованием сведений, составляющих государственную тайну;
- Поставка специализированных компонентов (Xilinx, Altera, Analog Devices, Intersil, Interpoint, Microsemi, Aeroflex, Peregrine, Syfer, Eurofarad, Texas Instrument, Miteq, Cobham, E2V, MA-COM, Hittite, Mini-Circuits, General Dynamics и др.);

Помимо этого, одним из направлений компании «ЭлектроПласт» является направление «Источники питания». Мы предлагаем Вам помощь Конструкторского отдела:

- Подбор оптимального решения, техническое обоснование при выборе компонента;
- Подбор аналогов;
- Консультации по применению компонента;
- Поставка образцов и прототипов;
- Техническая поддержка проекта;
- Защита от снятия компонента с производства.



#### Как с нами связаться

**Телефон:** 8 (812) 309 58 32 (многоканальный)

**Факс:** 8 (812) 320-02-42

**Электронная почта:** [org@eplast1.ru](mailto:org@eplast1.ru)

**Адрес:** 198099, г. Санкт-Петербург, ул. Калинина, дом 2, корпус 4, литера А.