

ISL26134AV28EV1Z

Evaluation Board User Guide

AN1672
Rev.2.00
Jan 9, 2018

General Description

The ISL26134AV28EV1Z provides a means to evaluate the functionality and performance of the [ISL26134](#) A/D converter.

The board includes an AT90USB162 microcontroller with a USB interface. The microcontroller interfaces to the ISL26134 ADC through a galvanically-isolated interface and provides serial communication through the USB between the board and the PC.

Software for the PC provides a Graphical User Interface (GUI) that allows the user to perform data capture, and then to process and plot the results of the time domain analysis, the histogram analysis, and/or the frequency domain analysis on the captured data. The GUI also enables the user to save conversion data from the ADC to a file, or to save the results of the analyzed conversion data.

Ordering Information

PART NUMBER	DESCRIPTION
ISL26134AV28EV1Z	Evaluation Board

Related Literature

- For a full list of related documents, visit our website
- [ISL26134](#) product page

Features

- Galvanically-isolated USB communication with PC
- On-board microcontroller
- On-board voltage reference
- Evaluation software
 - Time domain analysis
 - Noise histogram analysis
 - FFT analysis

Hardware

The ISL26134AV28EV1Z evaluation board provides the user a means of evaluating the ISL26134 Analog-to-Digital Converter (ADC). The ISL26134 is a high performance 24-bit ADC that includes a very low noise programmable gain amplifier. The ISL26134 offers gain selections of 1x, 2x, 64x, and 128x. It offers word rates of 10Sps and 80Sps (clock = 4.9152MHz). Gain and word rate selections are made by pin function control through jumper selections.

The board comes with an ISL26134 soldered in place. This can be removed and an ISL26132 soldered in its place.

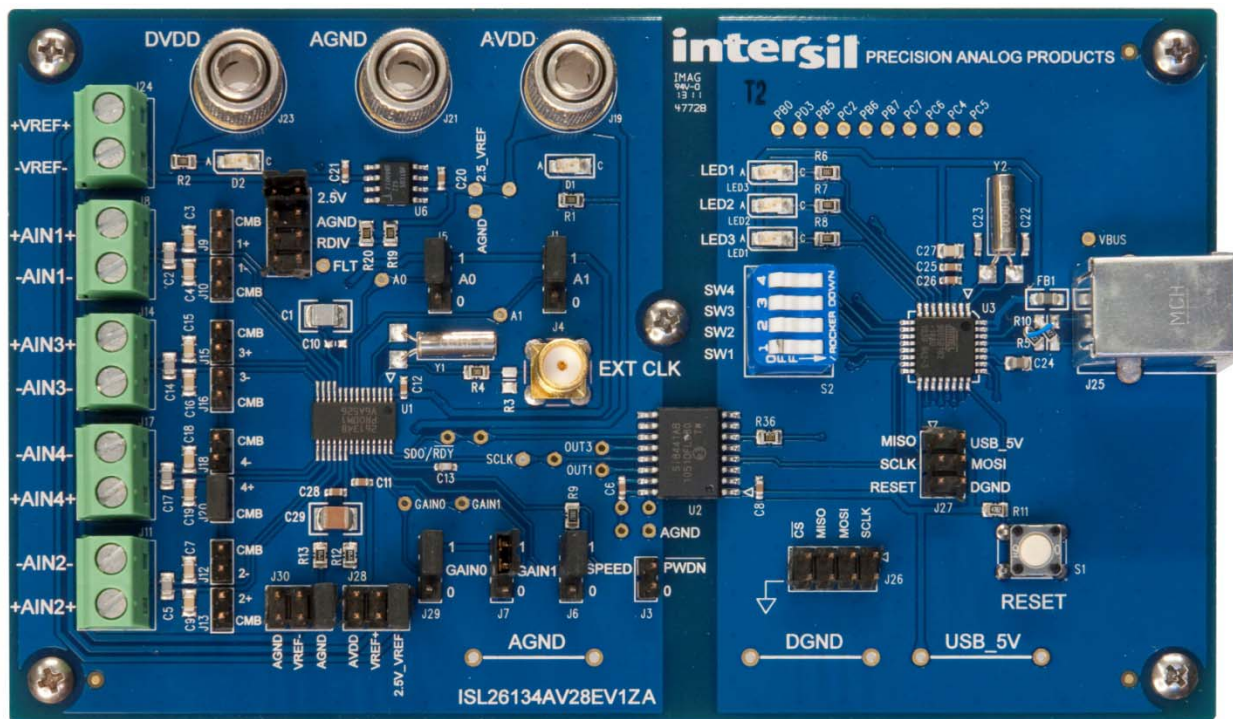

FIGURE 1. ISL26134 EVALUATION BOARD

Evaluation Board Overview

The ISL26134AV28EV1Z evaluation board is segmented into two sections. These sections are galvanically isolated with a multi-channel isolation chip. The ISL26134 ADC and its associated circuitry (voltage reference and input signal components) are isolated from the microcontroller-USB interface to the PC. The ADC and its associated circuitry are powered by a laboratory supply. The microcontroller with its USB interface is powered from the USB connection. Galvanic isolation is not necessary in every application. The purpose of the isolation is to eliminate noise from the USB ground power connection from affecting the sensitive measurements made by the ADC when used in the 64X or 128X gain settings.

The ADC section of the evaluation board has three banana jack power connections. One of these is AGND which serves as the power supply ground connection for the ADC segment of the board. The DVDD jack supplies the digital side of the ADC (3.3V to 5V). The AVDD jack supplies the analog portion of the ADC (5V) and powers the voltage reference. The voltage reference is a ISL21090BFB825Z-TK 2.5V reference. A header is provided to also use an external voltage reference for the ADC.

The microcontroller provides the USB interface to the PC. A software GUI is available to communicate with the microcontroller and provides the means to collect and analyze data for the ADC.

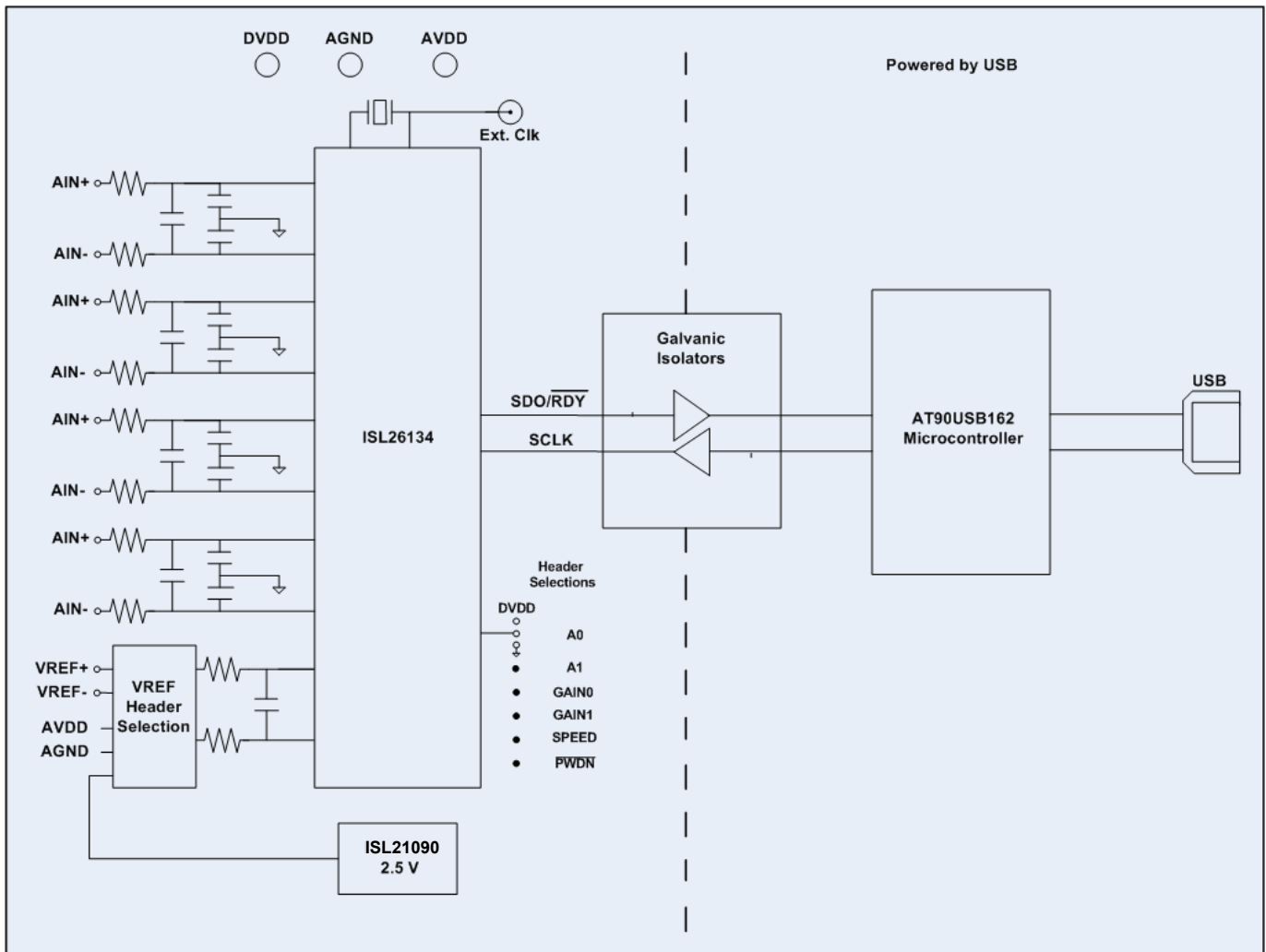

FIGURE 2. BLOCK DIAGRAM OF THE EVALUATION BOARD FOR THE ISL26134

ADC Section

The ADC offers different sample rates, gain, and input channel options. These are selected by setting jumpers on headers (1 = positive supply; 0 = ground) as shown in the table on the bottom of [Figure 3](#).

The ADC uses a 4.9152MHz crystal operating with an on-chip amplifier for its clock source. This can be disconnected and an external clock can be sourced to drive the clock input to the chip. Alternately, the XTALIN/CLOCK pin can be grounded and the ADC will operate from an on-chip RC type oscillator.

The board provides a 2.5V reference IC as the voltage reference for the ADC, or an external voltage can be connected to a terminal block and selected through jumpers on headers J28 and J30 as shown in [Figure 5, on page 6](#). These headers also provide the option of selecting AVDD and AGND as the inputs to VREF+ and VREF- on the ADC.

The evaluation board provides separate terminal connections for each of the differential signals into the ADC. These terminals are in shown in [Figure 4, on page 5](#). Be attentive of the labeling of the connections and their polarities when connecting external signals. The channel numbers on the terminal blocks are not in numeric order and some have their polarities labeled opposite of others.

Header connector J22 in [Figure 4](#) allows the user to select one of the following options for the common-mode voltage: the 2.5V voltage reference output, ground (AGND), a voltage generated by a resistor divider that divides the AVDD supply using two 1k Ω resistors, or to a voltage determined by the user which must be connected to the hole next to the header connection labeled FLT (Floating Input).

Each of the input channels has jumpers to allow the user to connect the common-mode voltage to either the AIN+ or the AIN- input. This enables the external circuit to be biased to a common-mode value supplied by the board. If both jumpers are put in place, the inputs will be shorted to the common-mode voltage. This provides a means for testing the noise performance of the ADC with its inputs shorted.

The ADC interfaces to the microcontroller through the galvanic isolators. The ADC side of the isolator chip is powered by the same supply that powers the DVDD supply of the ADC.

Power from an external supply must be provided to the DVDD (3.3V to 5V), AVDD (5V), and AGND banana plug connectors for the ADC portion of the board to function. LEDs will be illuminated by DVDD and AVDD when they are powered. Note that these supplies can be applied and removed without regard to whether the USB interface is connected and powered.

Microcontroller Section

[Figure 6](#) illustrates the microcontroller circuitry. A reset button is provided, but it is seldom necessary because the microcontroller has its own power-on reset which will initialize the microcontroller when the USB interface is connected to a powered PC. Power for the microcontroller section comes from the USB interface. The microcontroller circuit includes a DIP switch and some LEDs. The board is shipped from the factory with four switches of the DIP switch set in the OFF position. This is required for normal operation.

The microcontroller circuit includes a header through which the flash memory on the microcontroller is programmed. A second header provides a means for the user to monitor the signals (SCLK and SDO/RDYb — on the J22 header these are labeled as MOSI and MISO [Master Out, Slave In and Master In, Slave Out], respectively) from the microcontroller that communicate with the ADC.

One LED lights up to indicate when power is applied to the USB interface. A second LED indicates when the microcontroller is available to collect data from the ADC. The microcontroller communicates with the ADC through the galvanic isolator chip. The microcontroller side of the isolator is powered by the voltage from the USB connection. The USB connection can be powered or unpowered without regard to the supplies to the ADC side of the board. There is no power sequence requirement between the two sections of the board.

Schematics

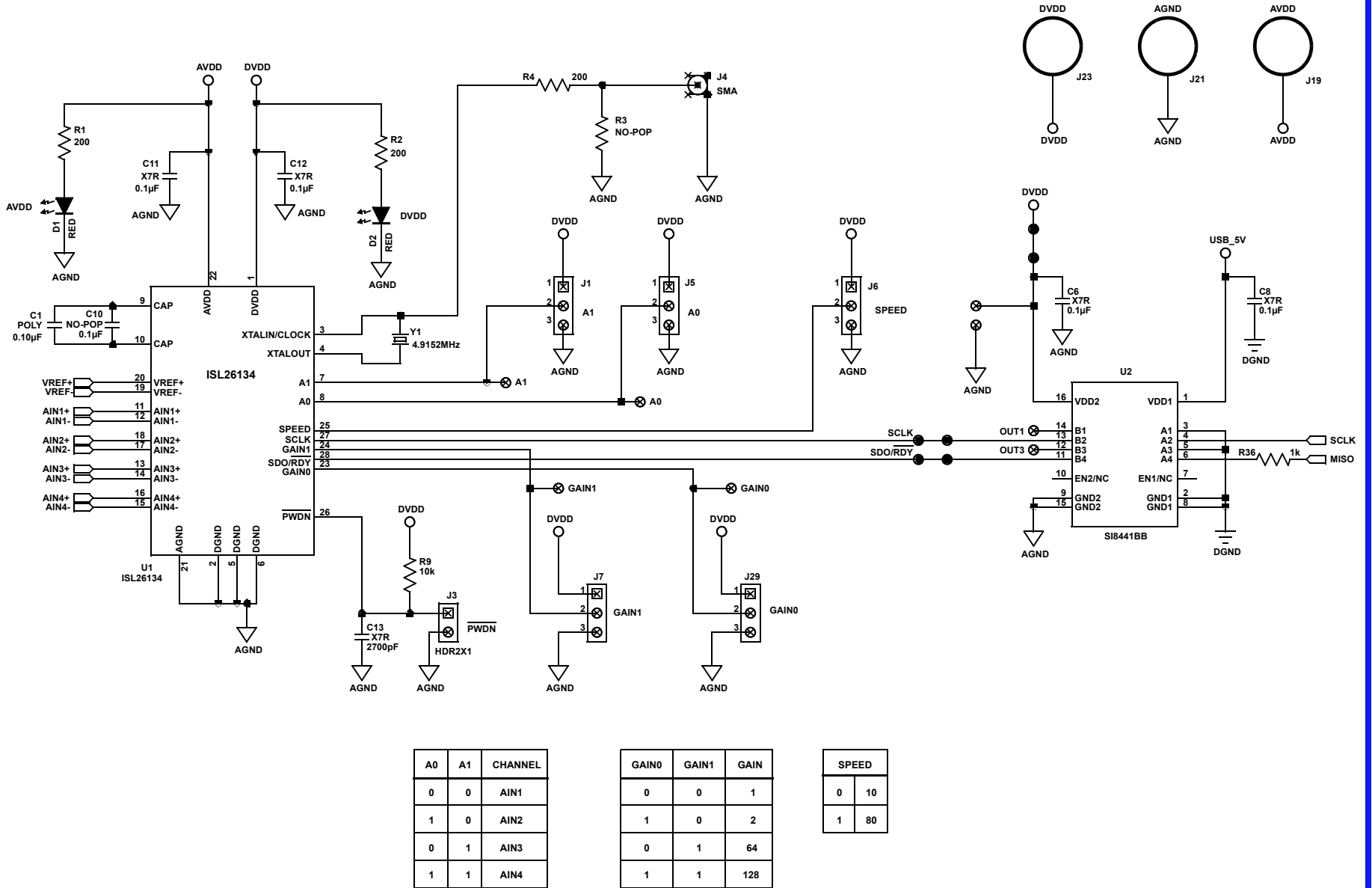

A0	A1	CHANNEL
0	0	AIN1
1	0	AIN2
0	1	AIN3
1	1	AIN4

GAIN0	GAIN1	GAIN
0	0	1
1	0	2
0	1	64
1	1	128

SPEED
0
10
1
80

FIGURE 3. ADC WITH POWER SUPPLY CONNECTIONS, JUMPER SELECTIONS, AND ISOLATOR INTERFACE

Schematics (Continued)

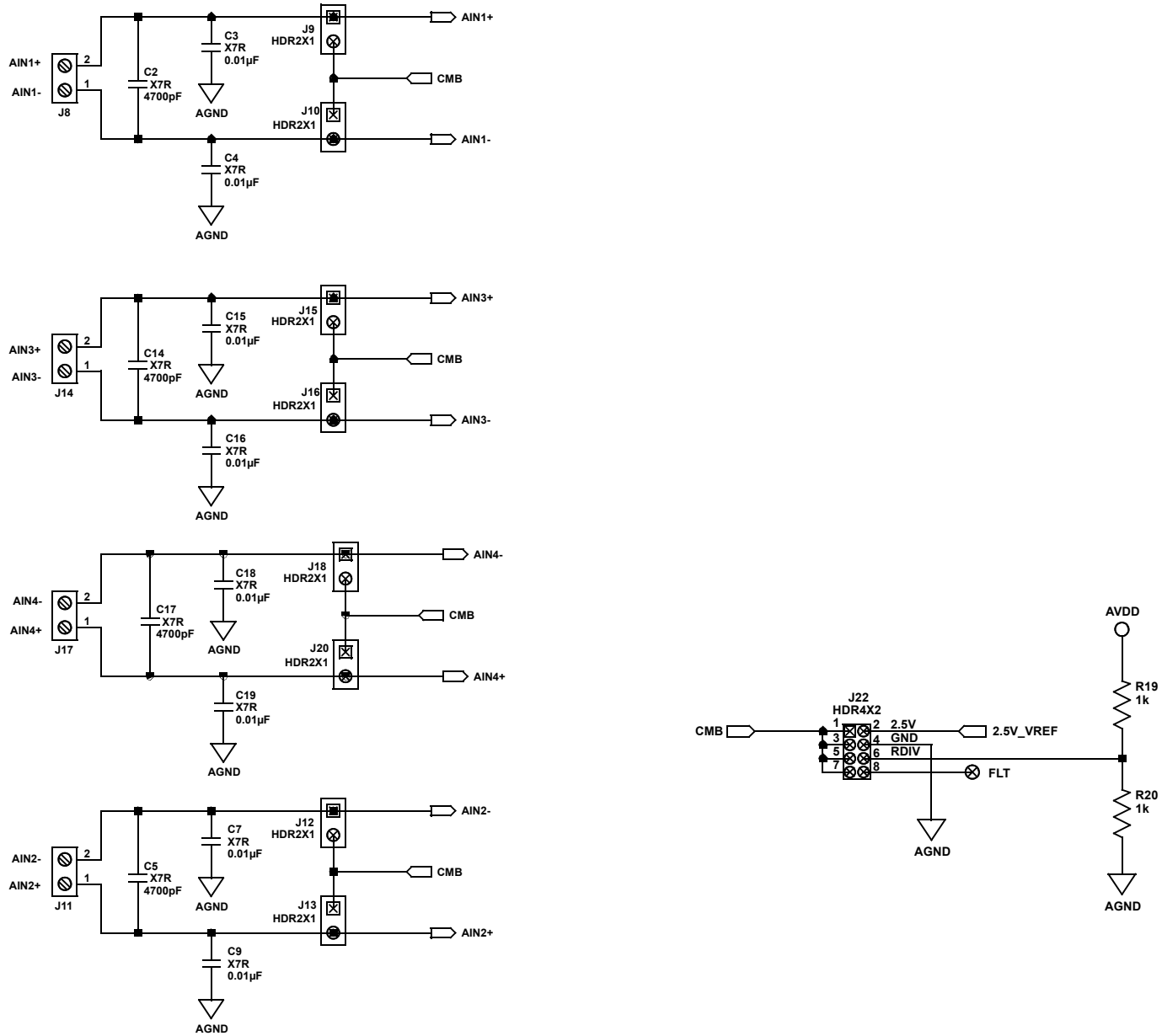

FIGURE 4. ANALOG INPUTS AND COMMON MODE SELECTION SELECTIONS

Schematics (Continued)

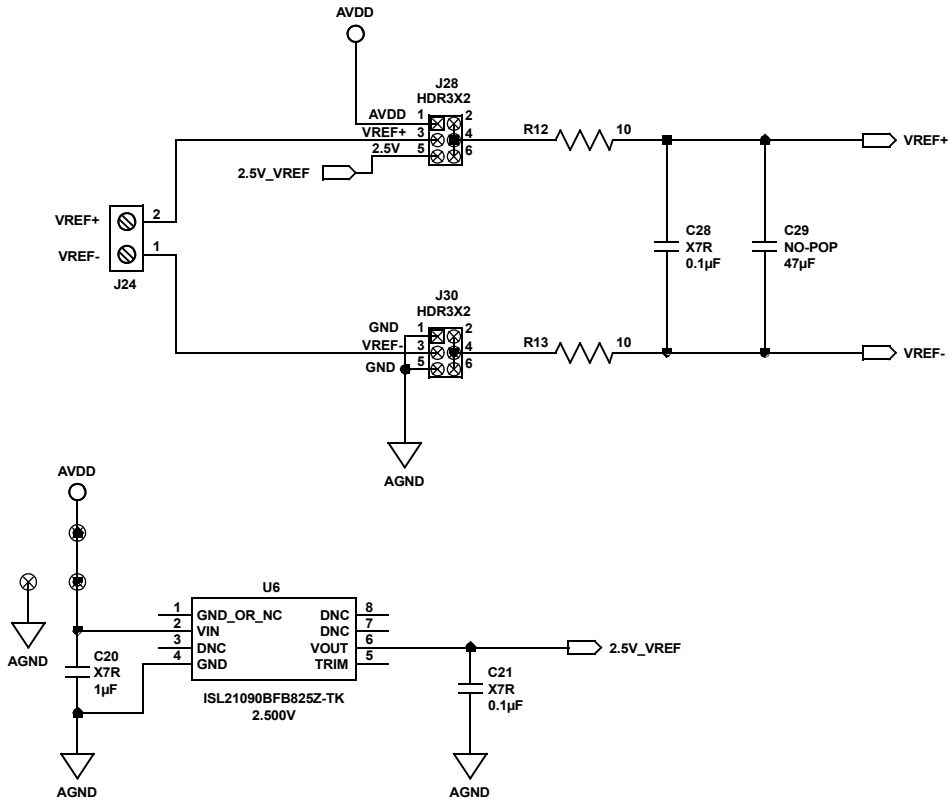

FIGURE 5. VOLTAGE REFERENCE AND VOLTAGE REFERENCE SELECTION OPTIONS

Schematics (Continued)

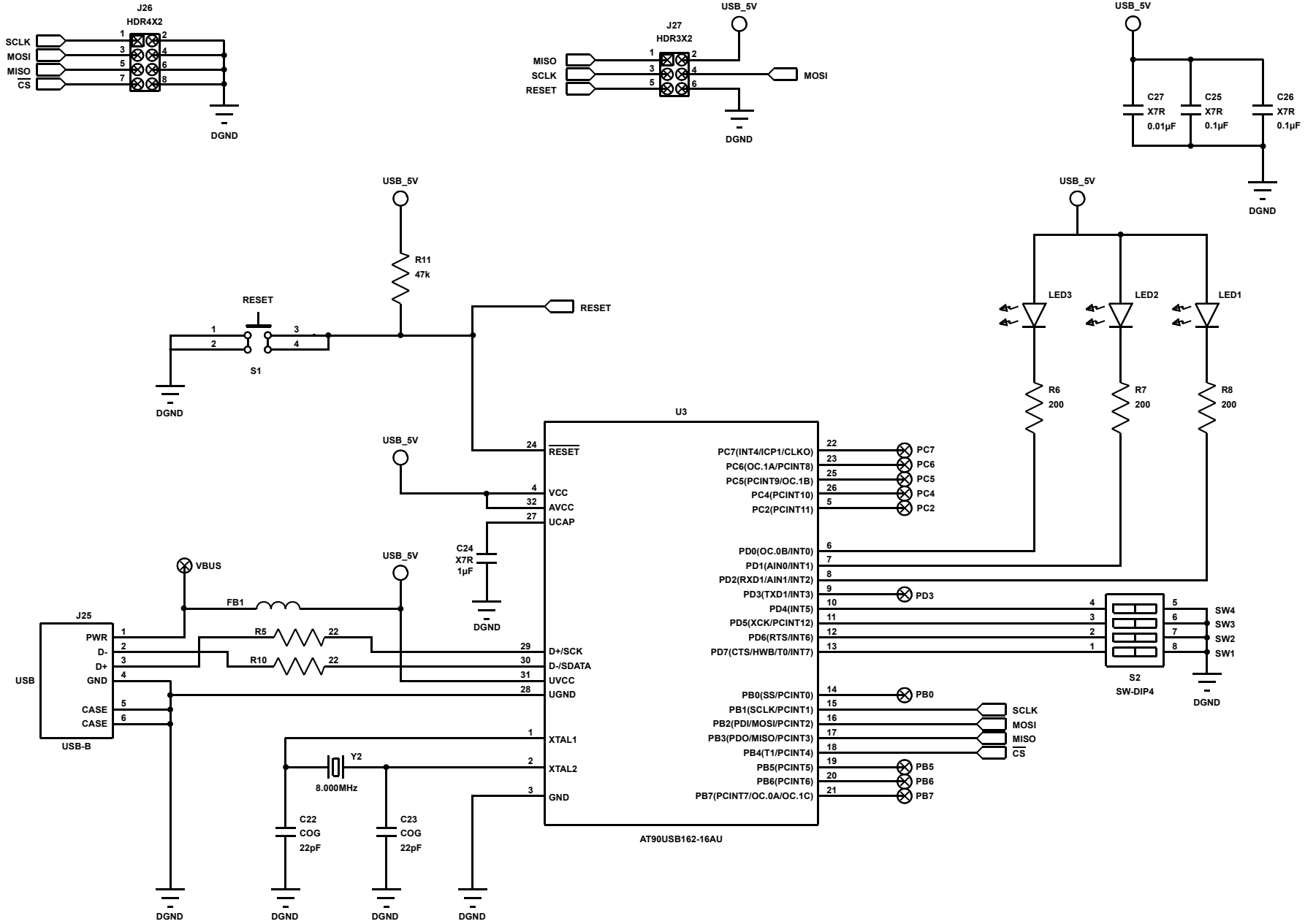

FIGURE 6. MICROCONTROLLER WITH USB INTERFACE

Software

The evaluation board has software available that runs on the PC. ISL26134AV28EVZ1 evaluation boards manufactured before June 2014, use different uC code (Version 5) and a different PC GUI (Version 1.1). Boards manufactured after June 2014, use uC code Version 7 and PC GUI Version 4.

The software (uC code Version 7 and PC GUI Version 4) is designed to operate under Windows XP or later.

Read "[Appendix #1 How to Obtain and Install the GUI Software](#)" on page 19 to obtain the internet link to download the GUI software.

Once the PC software is copied onto the PC, click on the **isl261xx_installer_v4.exe** file and follow the on screen instructions to load the software. Note that the software uses the USB interface to communicate with the evaluation board. The software uses the USB HID driver that is part of the Windows operating system so it is not necessary to load any other drivers for the USB interface.

Running the GUI

Before starting the software, the evaluation board should be connected to the PC with a USB cable.

With the board connected by USB, run the GUI program by selecting Start → All Programs → Renesas → ISL261XX Evaluation Software => ISL261XX Evaluation Software.

If the software is started before the connection to the board is made, the GUI will output a message (USB Status: Not Connected) as shown in [Figure 7](#).

If this occurs, connect the evaluation board to the PC with the USB cable. The message should automatically change as shown in [Figure 8](#).

Note that the font of the text at the top of the GUI and the color of the top section and the trim of the GUI window is dictated by the Theme selection set in the Windows OS so it may have a different color on your computer display than what is shown in this document.

Using the GUI Software

When the GUI software is started and the USB connection is established, the GUI will present a menu as shown in [Figure 8](#). The **Initialize** button is colored red to indicate that it is waiting for a part number to be chosen in the **Device Selection** window.

The user must pick a part number from the Device Selection Window and click on the **Initialize** button. This causes the software GUI to be configured to support the selected device. There is no evaluation board for the ISL26132. Select ISL26134 to use the software GUI with the evaluation board referenced in this document.

Once the **Initialize** button is clicked with the ISL2613X selection, the screen will change slightly to indicate the output word rate options of the ISL2613X ADC. Note that the actual word rate used by the ADC is selected by a jumper on the evaluation board. The selection here in the Sample Frequency window only tells the GUI software which sample rate is to be used for the frequency axis when graphing the spectrum for the spectral (FFT) plot.

The top line of the menu page has two options, **File** and **About**. The **File** selection will be discussed after the **Time Domain**, **Histogram** and **Frequency Domain** windows are selected. When the GUI is started it sends a command to the evaluation board and tells the microcontroller to send back the version of the code that is in the microcontroller. If **About** is selected, the GUI will open a window that indicates the version number of the microcontroller code, and the version of the GUI software, as shown in [Figure 10](#).

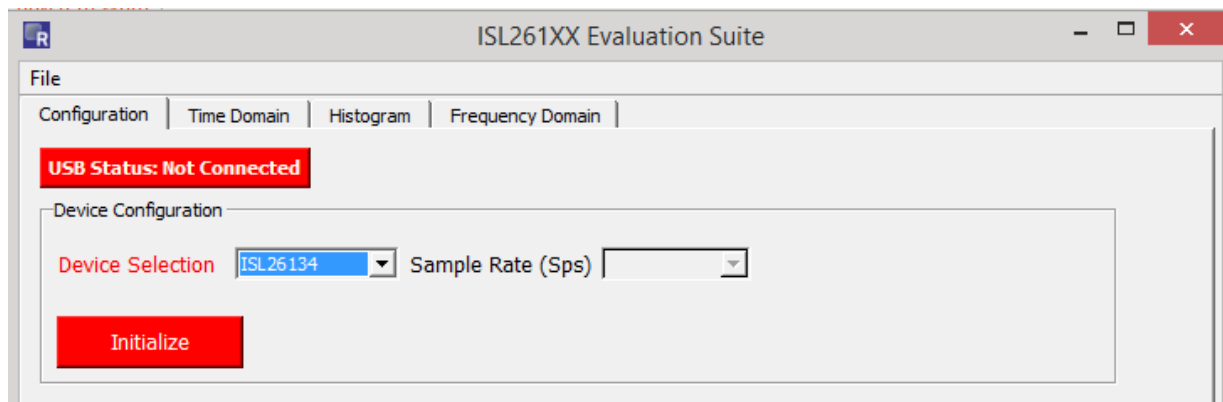

FIGURE 7. USB STATUS: NOT CONNECTED

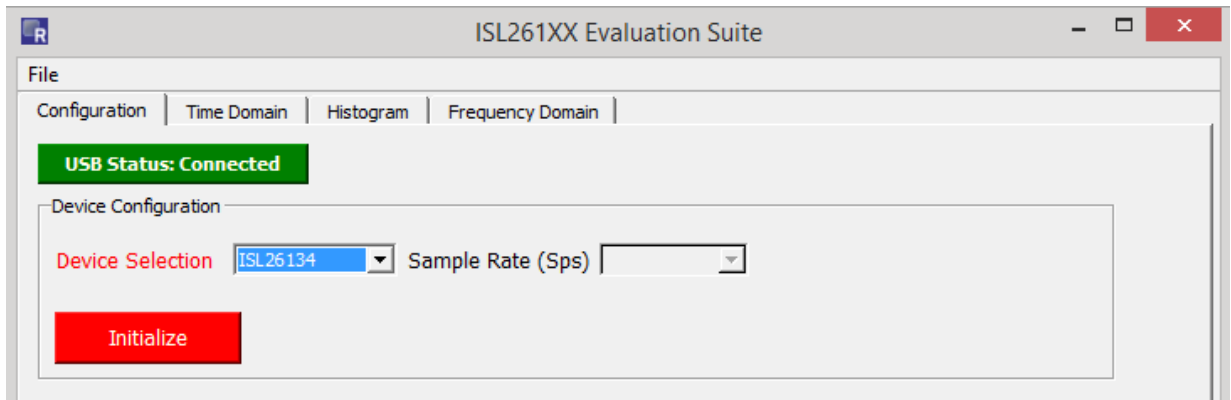

FIGURE 8. USB STATUS: CONNECTED

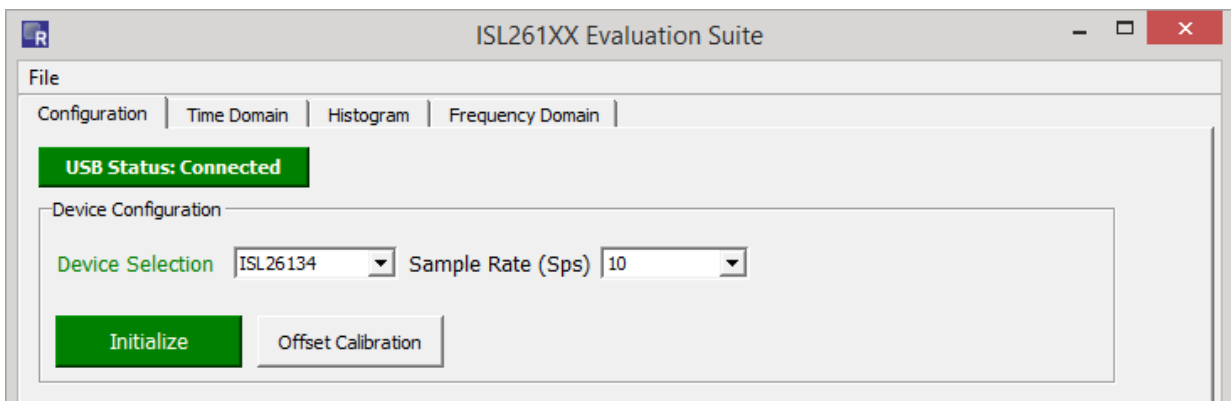

FIGURE 9. USB STATUS

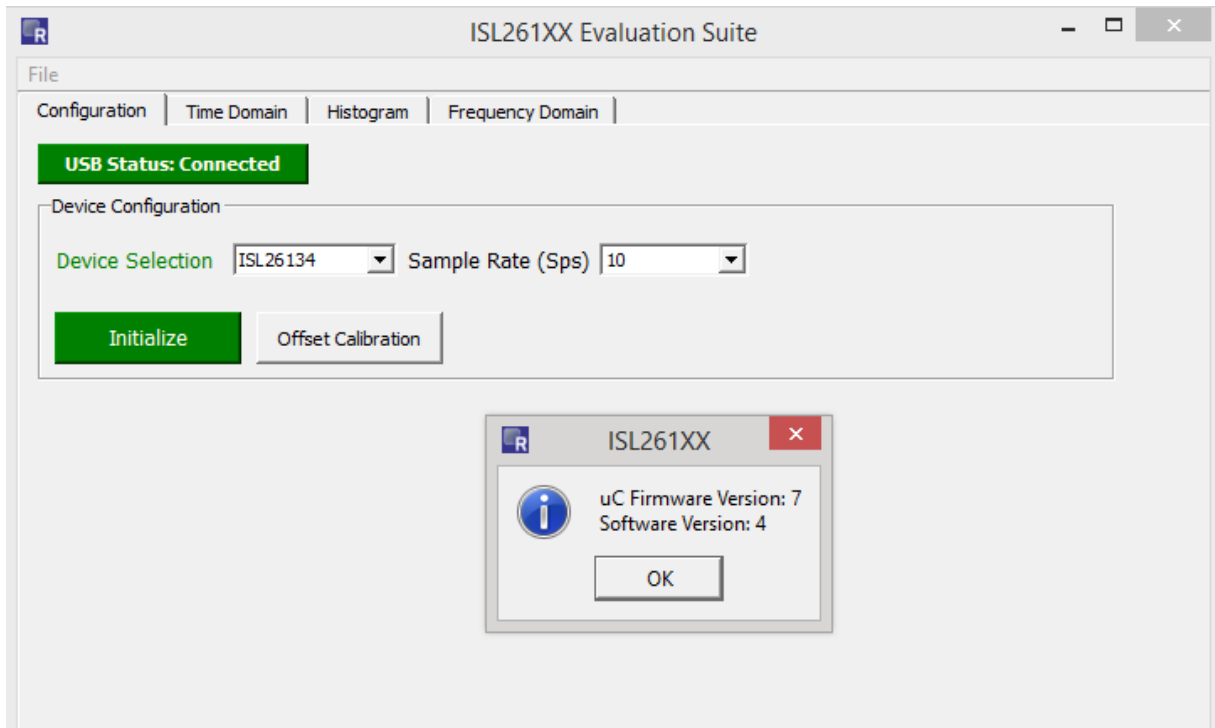

FIGURE 10. About: FIRMWARE AND SOFTWARE VERSIONS

Time Domain Window

The **Time Domain** window allows the user to collect samples from the ADC on the evaluation board and display them in the time domain. The number of samples is initially defaulted at 64, but can be set in a pull-down window from 1 to 1048576. Realize the time involved if a large number of samples is requested on an ADC with a slow sample rate. When the **Acquire** button is clicked,

the samples will be collected and the samples up to 256 will be displayed in the graphing window. If greater than 256 samples are collected, then, after the samples are captured and the first 256 are displayed, the time plot of the entire sample set can be displayed by clicking on the **Pop Out** button. [Figures 11](#) and [13](#) illustrate the capture of 4096 samples. The window in [Figure 11](#) displays only the first 256 samples. [Figure 13](#) illustrates the results when the **Pop Out** button has been selected.

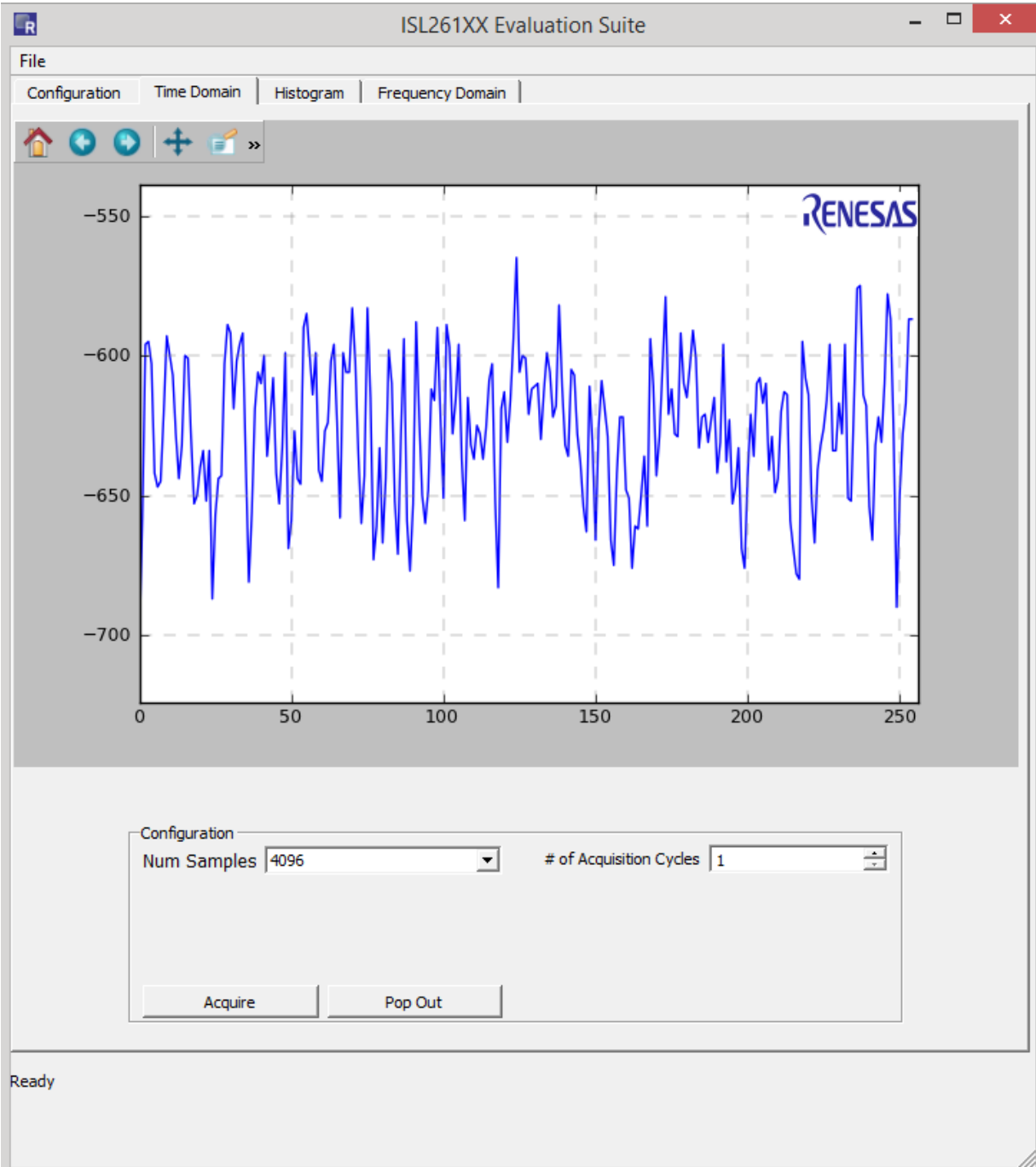

FIGURE 11. TIME DOMAIN WINDOW, "About" BUTTON RESULTS (256 SAMPLES)

Buttons at the top of the plot provide several user graph tool functions as shown in [Figure 12](#).

These are also available in the **Histogram** and **Frequency Domain** windows.

House: Zooms to the original zoom scale factor.

Left/Right: Goes back/forward 1 zoom command. If you zoom in twice and want to go back to the first zoom, click the left arrow.

Four Points: Moves the axes around.

Magnifying Glass: Zoom box.

Scaling Icon (Up/down/left/right): Changes the size of the plot in the window. You can scale the graph as large as the border.

Check Box: Allows customization of axis labels/plot title as shown in [Figure 13](#).

Disk: Saves the plot as an image. When selected, a window will open that offers several image format options.

Once the data from the ADC has been captured, the data can be saved to a file. The histogram data and the spectrum data can also be saved. See [“Appendix #2 Data File Formats” on page 19](#) for a discussion of the formats of the saved files. Note that the raw data (conversion words from the ADC) files can also be read back into the GUI once saved or, data collected from another source can be read into the GUI software for analysis if the proper data format is used. See [“Appendix #2 Data File Formats”](#) for details.



FIGURE 12. TOP OF PLOT GRAPH TOOLS

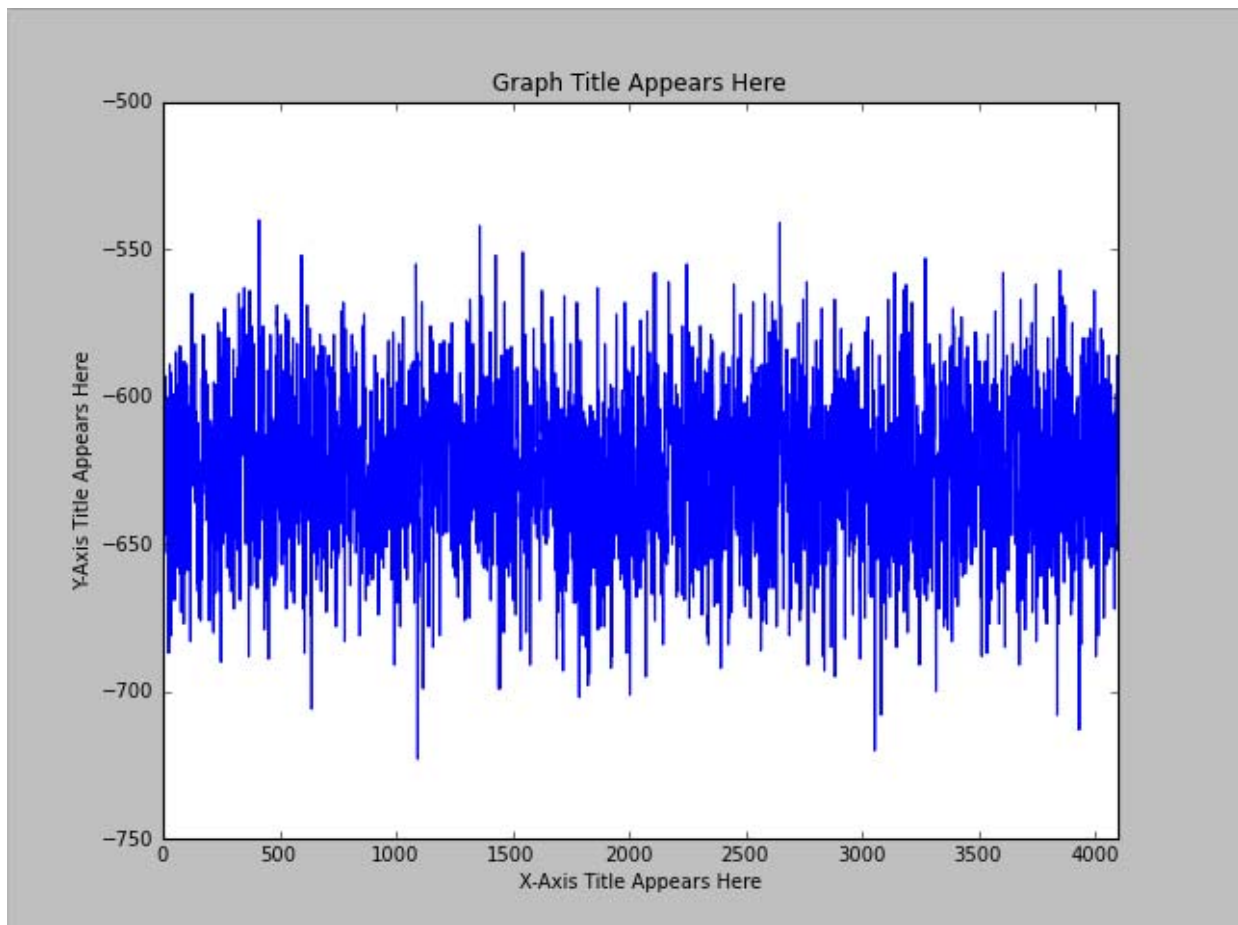

FIGURE 13. TIME DOMAIN WINDOW, “Pop Out” BUTTON RESULTS

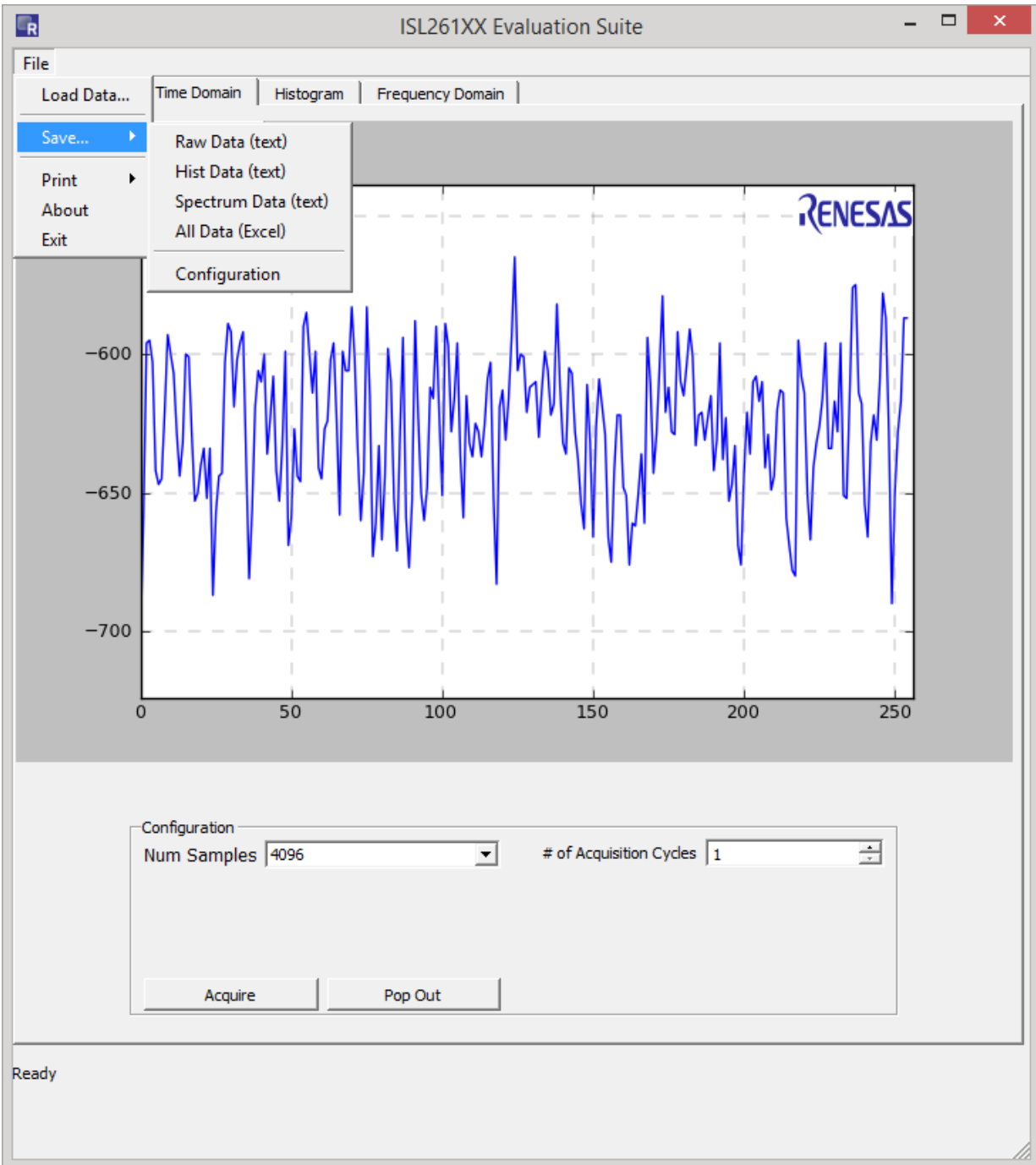

FIGURE 14. "Save" OPTIONS

Histogram Window

If the user clicks on the histogram window after collecting data using the **Time Domain** window, the histogram of the time domain data will be plotted. Alternatively, the **Histogram** window provides the user options to set the number of samples to be collected and to acquire a new sample set based upon this selection. The **Bin Width** window allows the user to set the

number of converter codes that are counted in one bin of the histogram. This number is defaulted to "1".

When the histogram is plotted, the plot includes markers for the mean value (red vertical line) and for one standard deviation from the mean on each side (green dashed lines). Signal statistics are listed in the plot itself and in the text boxes below the graph. The **Pop Out** button shows the graph without the statistics listed.

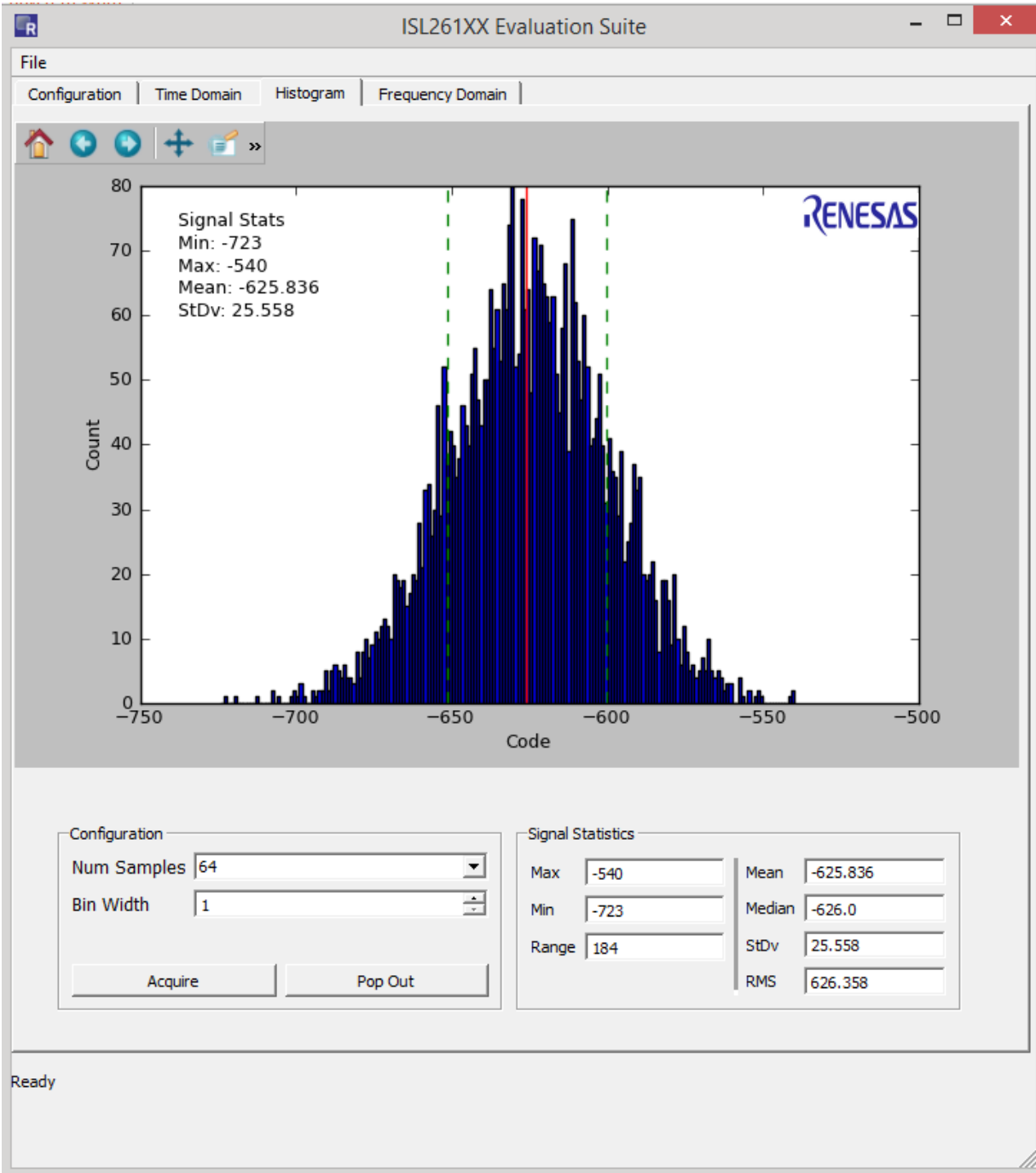

FIGURE 15. HISTOGRAM WINDOW

Frequency Domain

If the user has collected data in either the Time Domain window or the Histogram window, and then clicks on the Frequency Domain menu option, the data will be processed with the FFT algorithm and the resulting spectral information will be displayed, as shown in [Figure 16](#). The red lines indicate harmonics. If no signal is present, the software assumes the highest point in the spectrum is the fundamental. If the **log(freq)** check box is checked, the spectral plot will be graphed with the frequency axis on a Log scale, as shown in [Figure 19](#). If the **Grounded Input Test** check box is checked, and data is collected

with the input to the converter shorted, the GUI software will calculate the various parameters such as SNR (Signal-to-Noise Ratio) by computing the ratio of an artificial full-scale sine wave to the total noise in the bandwidth. The **Grounded Input Test** check box should only be checked if there is no actual signal input into the converter. Note that if the **Grounded Input Test** check box is not checked, the software will compute parameters such as SNR, by calculating the ratio of the largest magnitude component in the spectrum (other than the DC offset) to the noise.

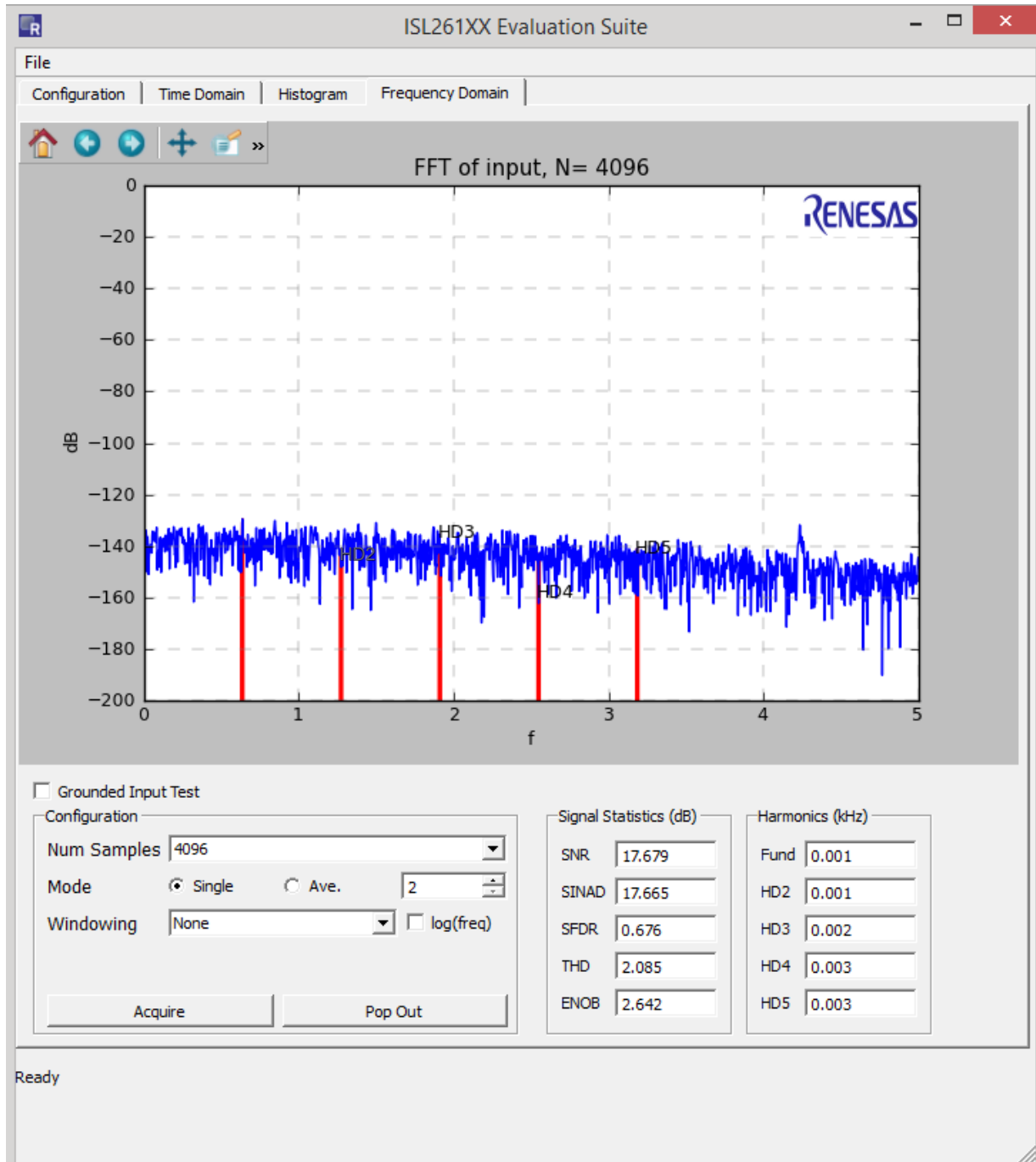

FIGURE 16. FREQUENCY DOMAIN

There are several different selectable options in the Frequency Domain window. The number of samples can be set up to 1048576 using a pull-down menu as shown in [Figure 17](#). Note that the Frequency Domain software must have at least 1024 samples to compute a proper spectral plot.

The software also allows a number of different window functions to be used. The different windowing options can be selected in the Windowing pull-down menu as shown in [Figure 18](#). These are normally used when testing is performed with a sine wave as the input signal.

[Figure 19](#) illustrates the spectral plot of one data set of 4096 samples. The results of the FFT can be averaged by setting the Mode radio button option to Ave. and then using the window next to the "Ave." button to set the number of data sets to be averaged. When averaging is performed, the output results of many FFTs are averaged and produce a spectral plot with smoothed (averaged) spectrum as shown in [Figure 20](#).

Remember that the spectrum plot data can be saved by clicking on the File → Save → Spectrum Data option at the top of the window.

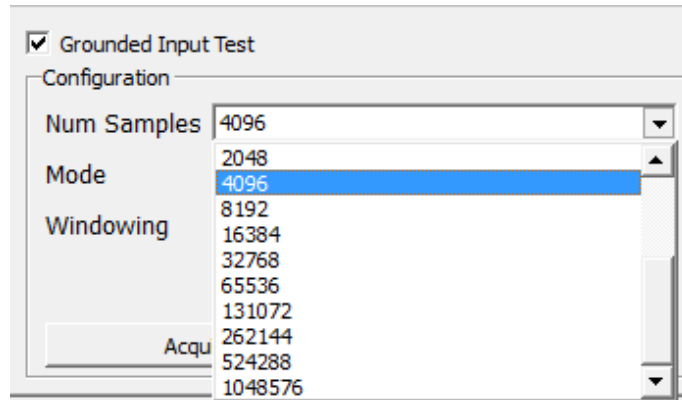

FIGURE 17. Num Samples PULL-DOWN WINDOW

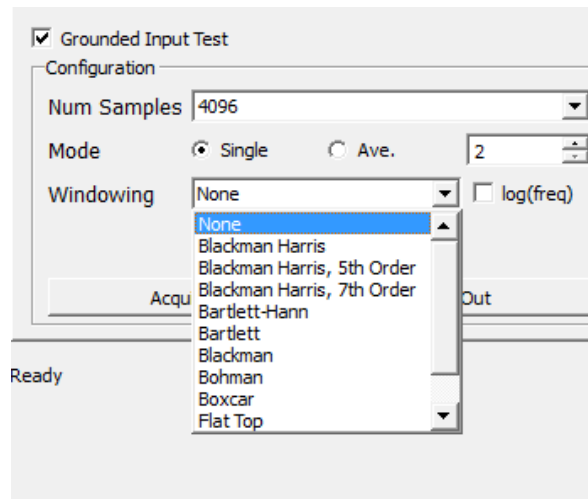

FIGURE 18. Windowing PULL-DOWN WINDOW

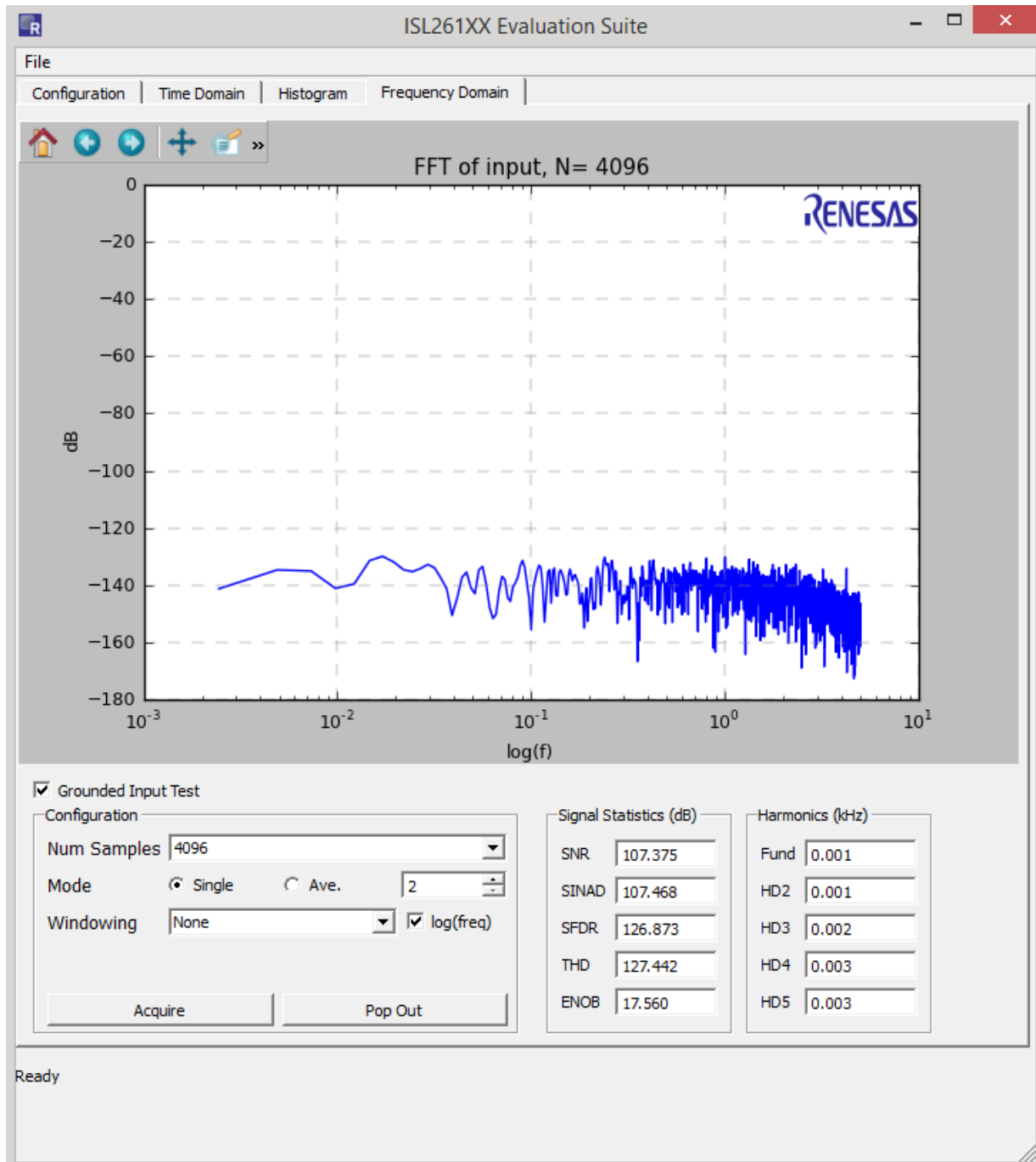

FIGURE 19.

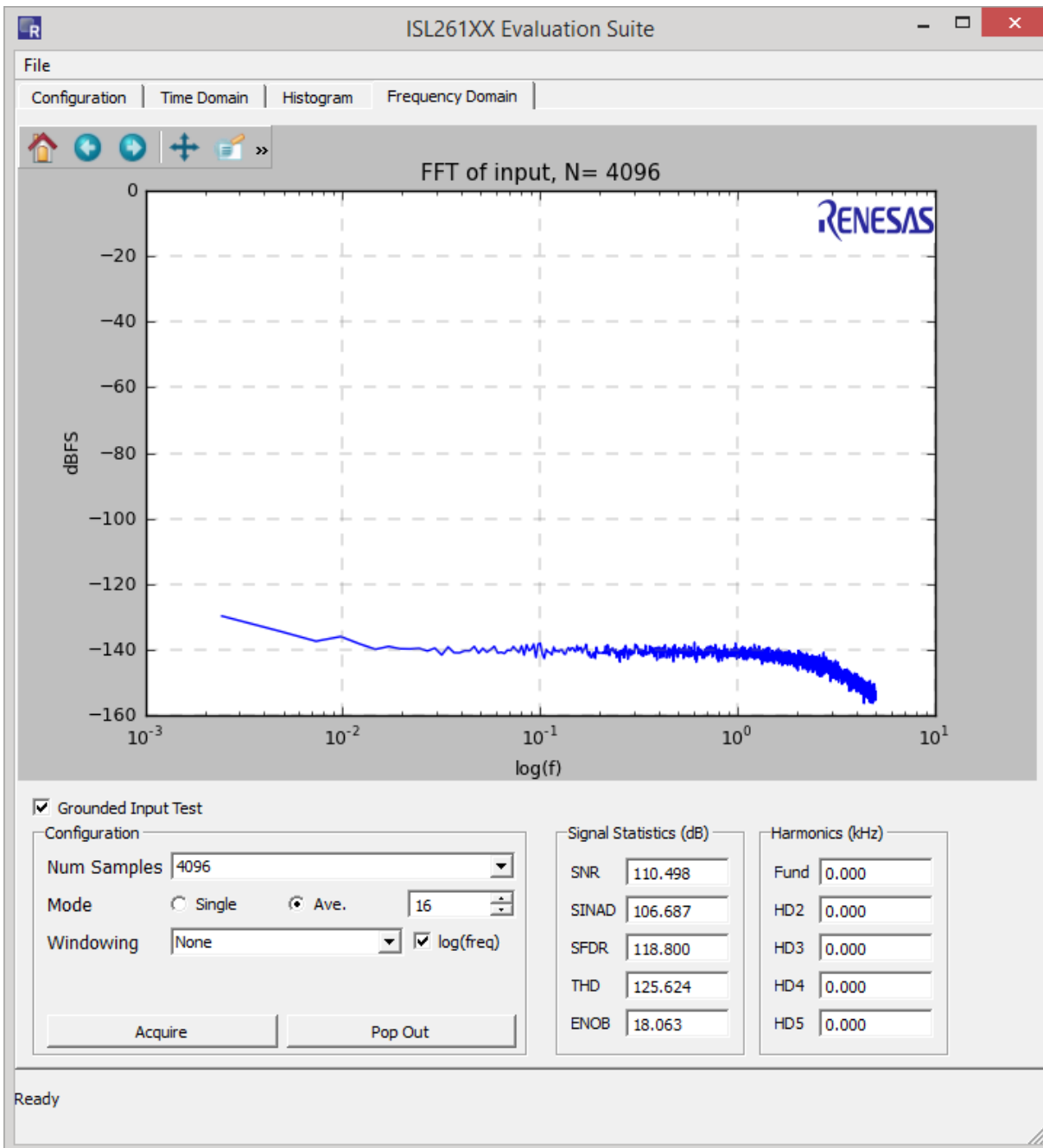

FIGURE 20.

ISL26134AV28EV1Z Bill of Materials

ITEM	QTY	REFERENCE	PART NUMBER	MANUFACTURER	DESCRIPTION	NOTES
1	1	C1	ECH-U1C104JX5	PANASONIC	CAP, 0.10 μ F, 5%, PPS FILM, 1210	
2	4	C2, C5, C14, C17	C0805C472J5RAC	KEMET	CAP, 4700pF, X7R, 0805, 50V, 5%	
3	9	C3, C4, C7, C9, C15, C16, C18, C19, C27	C0805C103J5RAC	KEMET	CAP, 0.01 μ F, X7R, 0805, 50V, 5%	
4	9	C6, C8, C10, C11, C12, C21, C25, C26, C28	C0603C104J3RACTU	KEMET	CAP, 0.1 μ F, X7R, 0603, 25V, 5%	
5	1	C13	C0603C272J5RAC	KEMET	CAP, 2700pF, X7R, 0603, 50V, 5%	
6	1	C20	C0603C105K4RACTU	KEMET	CAP, 1 μ F, X7R, 0603, 16V, 10%	
7	2	C22, C23	C0603C220J5GAC	KEMET	CAP, 22pF, COG, 0603, 50V, 5%	
8	1	C24	C0805C105J4RAC	KEMET	CAP, 1 μ F, X7R, 0805, 16V, 5%	
9	1	C29	C1210C476M9RACTU	KEMET	CAP, 47 μ F, 20%, 6.3V, X7R, 1210	
10	5	D1, D2, LED1, LED2, LED3	SML-LX1206IC-TCR	LUMEX OPTO	LED, SMT 3216, RED	
11	1	FB1	MI0805M221R-10	LAIRD - SIGNAL INTEGRITY	FERRITE CHIP POWER 220 Ω SMD	
12	5	J1, J5, J6, J7, J29	TSW-103-07-G-S	SAMTEC	STAKE HEADER, 3x1, 0.1" CTR, GOLD	
13	9	J3, J9, J10, J12, J13, J15, J16, J18, J20	TSW-102-07-G-S	SAMTEC	STAKE HEADER, 2x1, 0.1" CTR, GOLD	
14	1	J4	5-1814832-1	TYCO	CONNECTOR, SMA, GOLD PLATED	
15	5	J8, J11, J14, J17, J24	1729128	PHOENIX CONTACT	CONN TERM BLOCK 2POS 5.08MM	
16	3	J19, J21, J23	111-2223-001	EMMERSON	BINDING POST, GROUNDED TYPE NICKEL PLATED	
17	2	J22, J26	TSW-104-07-G-D	SAMTEC	STAKE HEADER, 4x2, 0.1" CTR, GOLD	
18	1	J25	67068-9000	MOLEX	CONN USB RT ANG RECPT TYPE B WHT	
19	3	J27, J28, J30	TSW-103-07-G-D	SAMTEC	STAKE HEADER, 3x2, 01." CTR, GOLD	
20	6	R1, R2, R4, R6, R7, R8	CRCW08052000F	DALE	RES, 200 Ω , 0805, 1/10W, 1%. 100ppm	
21	1	R3	NP-RES-0805	N/A	DO NOT POPULATE	
22	2	R5, R10	CRCW0805220J	DALE	RES, 22 Ω , 0805, 1/10W, 5%, 200ppm	
23	1	R9	CRCW0805103J	VISHAY	RES, 10k, 0805, 1/10W, 5%. 200ppm	
24	1	R11	CRCW0805473J	DALE	RES, 47k, 0805, 1/10W, 5%, 200ppm	
25	2	R12, R13	CRCW0805100J	VISHAY	RES, 10 Ω , 0805, 1/10W, 5%. 200ppm	
26	3	R19, R20, R36	CRCW08051001F	DALE	RES, 1k, 0805, 1/10W, 1%. 100ppm	
27	1	S1	B3F-1000	OMRON	SWITCH. PUSHBUTTON SPST 6x6mm	INSTALL AFTER WASH PROCESS
28	1	S2	5435640-2	TYCO	SWITCH DIP 4POS UNSEALED GOLD	
29	1	U1	ISL26134AV28	RENESAS	PRECISION ADC, TSSOP28 PKG	
30	1	U2	SI8441BB	SILICON LABS	DIGITAL ISOLATOR, QUAD CHANNEL, SOIC16 WIDE BODY PKG	
31	1	U3	AT90USB162-16AU	ATMEL	MICROCONTROLLER, USB CONTROLLER, 8-BIT, 16k FLASH, TQFN32 PKG	
32	1	U6	ISL21090BFB825Z-TK	RENESAS	VOLTAGE REFERENCE, 2.5V, \pm 0.02%, 7ppm, SOIC8	
33	1	Y1	CMR309T-4.9152MABJ-UT	CITIZEN	CRYSTAL, 4.9152MHz, TUBULAR, MINIATURE	
34	1	Y2	CMR309T-8.000MABJ-UT	CITIZEN	CRYSTAL, 8.000MHz, TUBULAR, MINIATURE	
35	12		881545-2	TE CONNECTIVITY	SHUNT, LP W/HANDLE, 2 POS, 30AU	
36	1		UB 12-03	SF CABLES	CABLE, USB 2.0 A MALE TO B MALE, 3FT	

Appendix #1 How to Obtain and Install the GUI Software

The following is the web page link for the ISL26134 device:
<http://www.intersil.com/products/ISL26134>

Go to this link to find the tab where the PC GUI software installer can be downloaded. Note that the software installer does have a license agreement that will be presented when the software is loaded onto your PC.

Appendix #2 Data File Formats

The GUI software allows the user to save data from the time domain (raw data), data from the histogram processing, and data from the spectrum processing segments of the software. It also allows raw data (time domain data) files to be read back into the GUI if they have the proper header and format.

Raw Data

As an example, a time domain collection of only 8 samples has been collected and saved to a file. The content of the file that is saved has the following format:

```
ISL2613X
80.0
24
8
-394
-361
-405
-411
-397
-416
-423
-416
```

The file has a header that consist of the part number (ISL26134), the sample rate (80), the number of bits in the conversion word (24), and the number of samples in the file (8). The header is followed by the 8 conversion words in signed decimal format.

Histogram Data

A data collection of 1024 data words was collected and the histogram performed. The histogram data was then saved into a file. The content of the file has the following format. The histogram statistics are listed first, followed by the converter codes and their respective histogram counts.

Signal Statistics

```
Min: -486
Max: -462
Range: 25
Mean: -472.762
StDv: 3.631
```

Code	Hits
-488	0
-487	0
-486	1
-485	0

-484	0
-483	4
-482	4
-481	7
-480	15
-479	29
-478	47
-477	54
-476	79
-475	84
-474	96
-473	112
-472	107
-471	99
-470	87
-469	71
-468	57
-467	40
-466	14
-465	11
-464	2
-463	3
-462	1
-461	0

Spectrum Data

A data set of 1024 points was collected at a sample rate of 80Sps. The FFT output will produce a spectrum plot with 512 Bins of magnitude data. Only the beginning and ending portion of the data file has been reproduced here. Note that the Bins start at 0 frequency and increase to one half the sample rate (40Hz). Note that the magnitude in dB is the magnitude of the noise in dB below full-scale rms but it is scaled based upon magnitude/ $\sqrt{\text{BIN}}$, not magnitude/ $\sqrt{\text{Hz}}$.

Freq	Magnitude (dB)
0.0	-152.176082921
0.078125	-150.765450438
0.15625	-151.161495054
0.234375	-161.302103964
0.3125	-152.403880548
0.390625	-153.371854853
0.46875	-147.933929413
0.546875	-140.814871676
XX	
39.375	-158.163736345
39.453125	-186.035243892
39.53125	-162.574730282
39.609375	-161.238997758
39.6875	-160.482611598
39.765625	-157.776276313
39.84375	-156.626469649
39.921875	-158.855304029

All Data (Excel)

The advantage of saving data with this option is that the raw data, the histogram data, and the spectrum data will all be saved on separate sheets of the spreadsheet, but the version of Excel that is supported only allows up to 32k samples.

Load Data Function

The GUI allows raw (time domain) data to be loaded back into the GUI. Alternately, the user might collect data in another system and import the conversion word data into the GUI to perform analysis. To be able to read the data the file must have the proper header (as discussed in [“Raw Data” on page 19](#) of this appendix).

The header must have a header with a part number (this can be something other than a chip number), sample rate, number of bits in the converter, and the number of samples, followed by the data in decimal format. The largest value of any reading cannot exceed one half 2^n (n = number of bits in the converter). For example, if the number of bits in the converter is 12, then the largest reading can be no greater than $(2^{12})/2$ or 2048.

```
ISL2613X > part number
80.0 > sample rate
24 > number of bits in the converter
8 > number of data samples in the file
-394 > conversion data in signed decimal
format
-361
-405
-411
-397
-416
-423
-416
```

Appendix #3 Evaluation Board Factory Jumper Settings

[Figure 21](#) indicates the position of the header shunts when the board is shipped from the factory.

Header J22 is connected with the 2.5V reference selected as the common mode voltage.

Headers J9 and J10 are shorted with shunts to connect the common mode voltage to the AIN1+ and AIN1- signals coming from the terminal block connector. This effectively shorts both inputs to channel 1 on the ADC to the common mode voltage and enables the ADC to be tested with a shorted input. One or both of these jumpers must be removed if the ADC is to measure a signal on this channel.

Headers J1 and J5: these are set to select logic 1, A0 = A1 = 0 => Channel = 1.

Headers J 29 and J7: These are set to select logic 1, Gain0 = Gain1 = 1 => Gain = 128X.

Header J6: Set to select logic 1. Speed = 1 => 80Sps.

Headers J28 and J30: the 2.5V_VREF option is selected on J28. The AGND option is selected on J30. These enable to 2.5V voltage reference chip to be the voltage reference for the ADC.

DIP switch: Switches S2-1, S2-2, S2-3 and S2-4 cannot be in the closed (ON) position. With all four switches in this position the board is in a factory test mode and will not function properly with the PC software GUI. If the factory test mode is selected LED3 will be lighted.

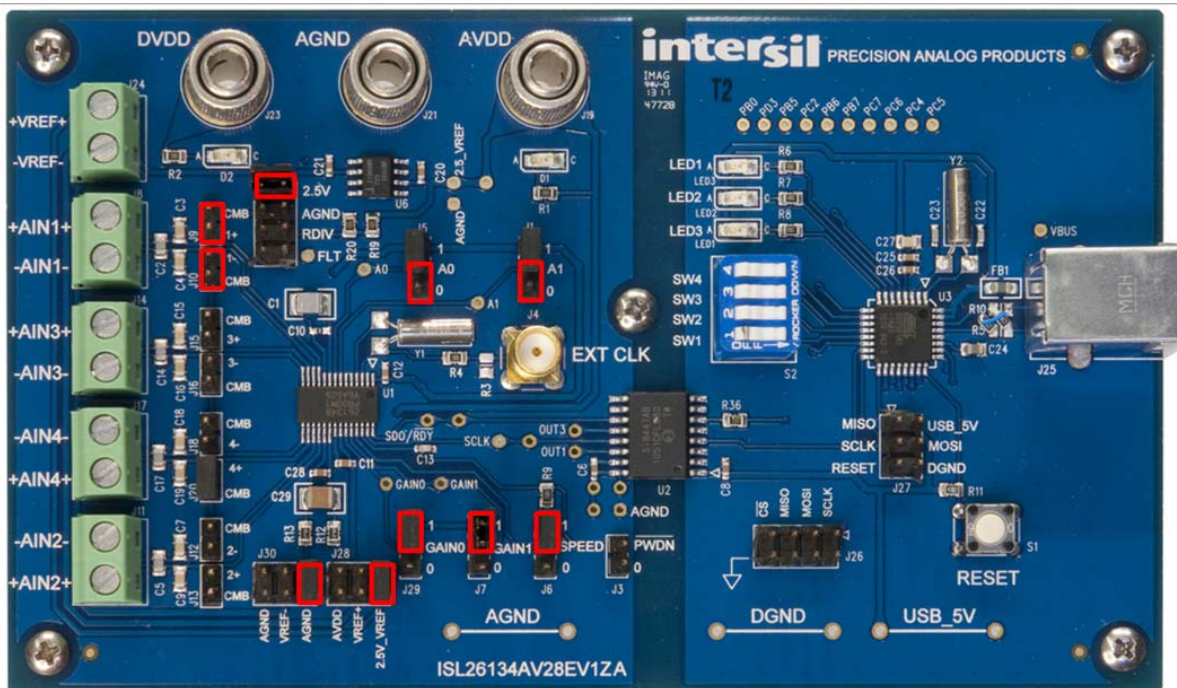

FIGURE 21. EVALUATION BOARD INDICATING HEADER SHUNT POSITIONS

Appendix #4 Evaluation Board Layout and Component Placement

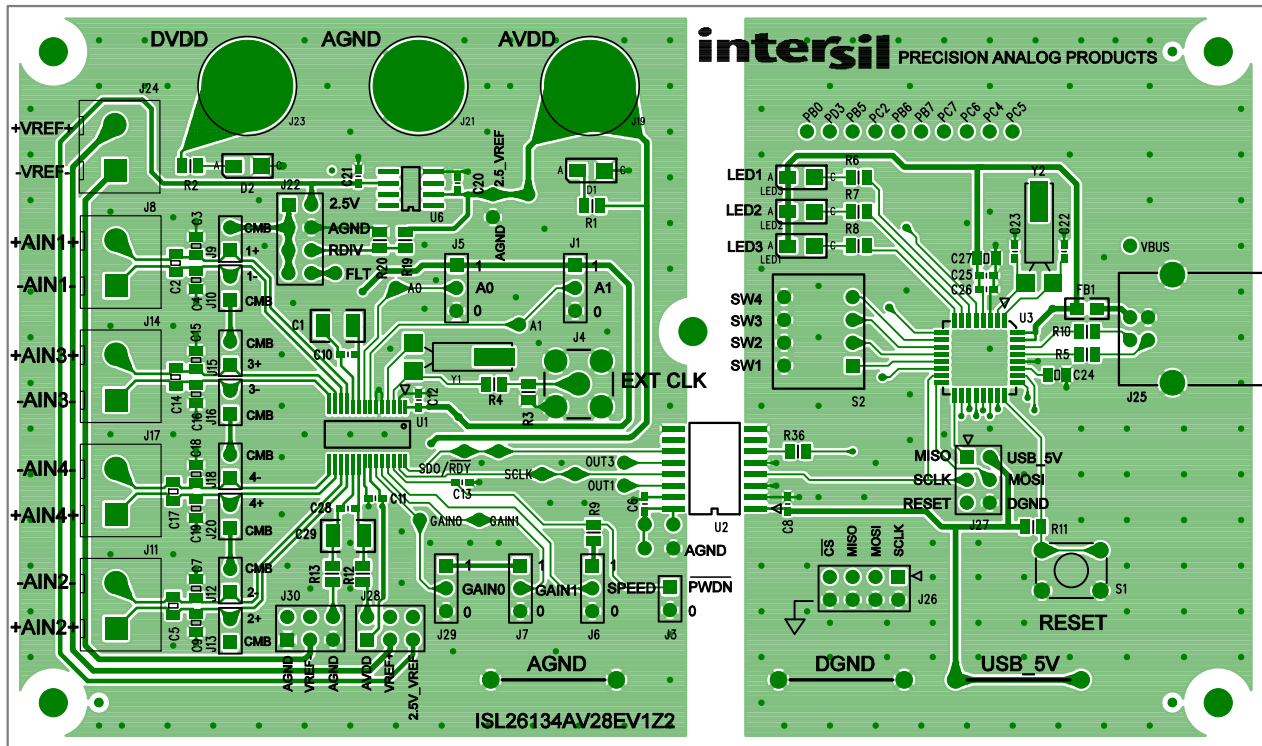

FIGURE 22. TOP LAYER

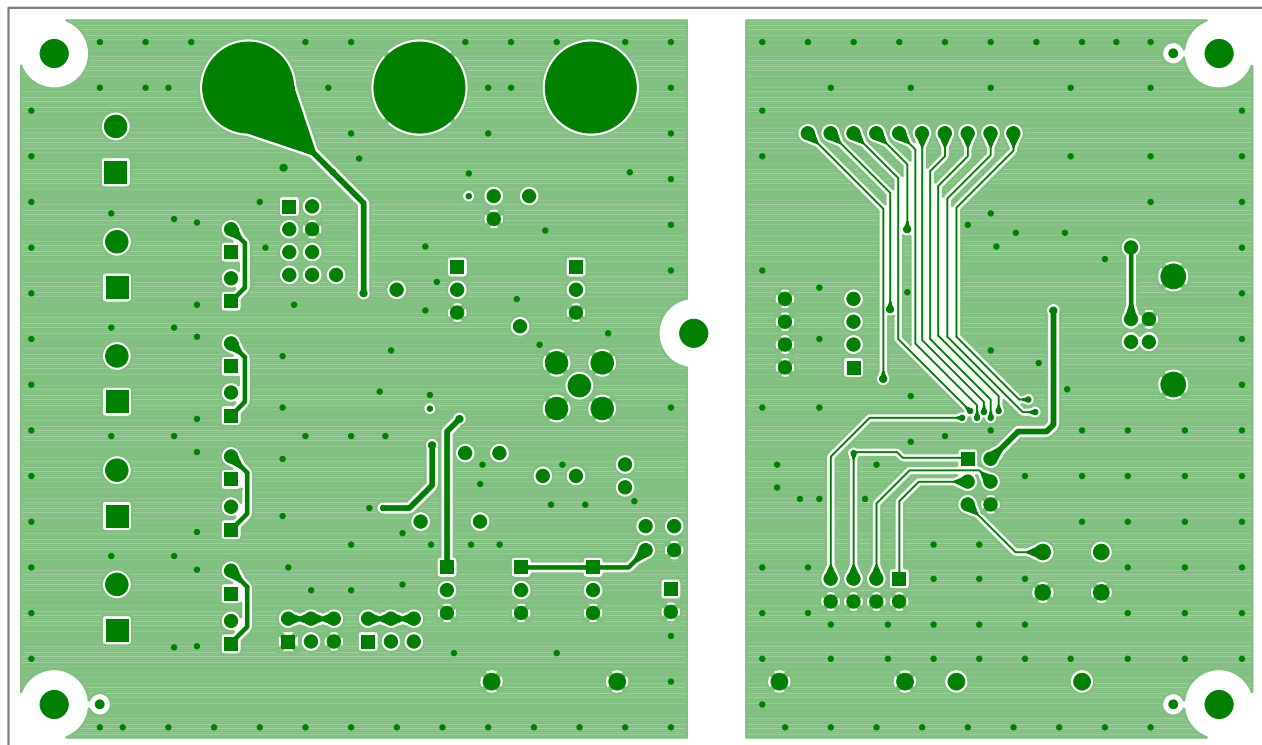

FIGURE 23. BOTTOM LAYER

Appendix #4 Evaluation Board Layout and Component Placement (Continued)

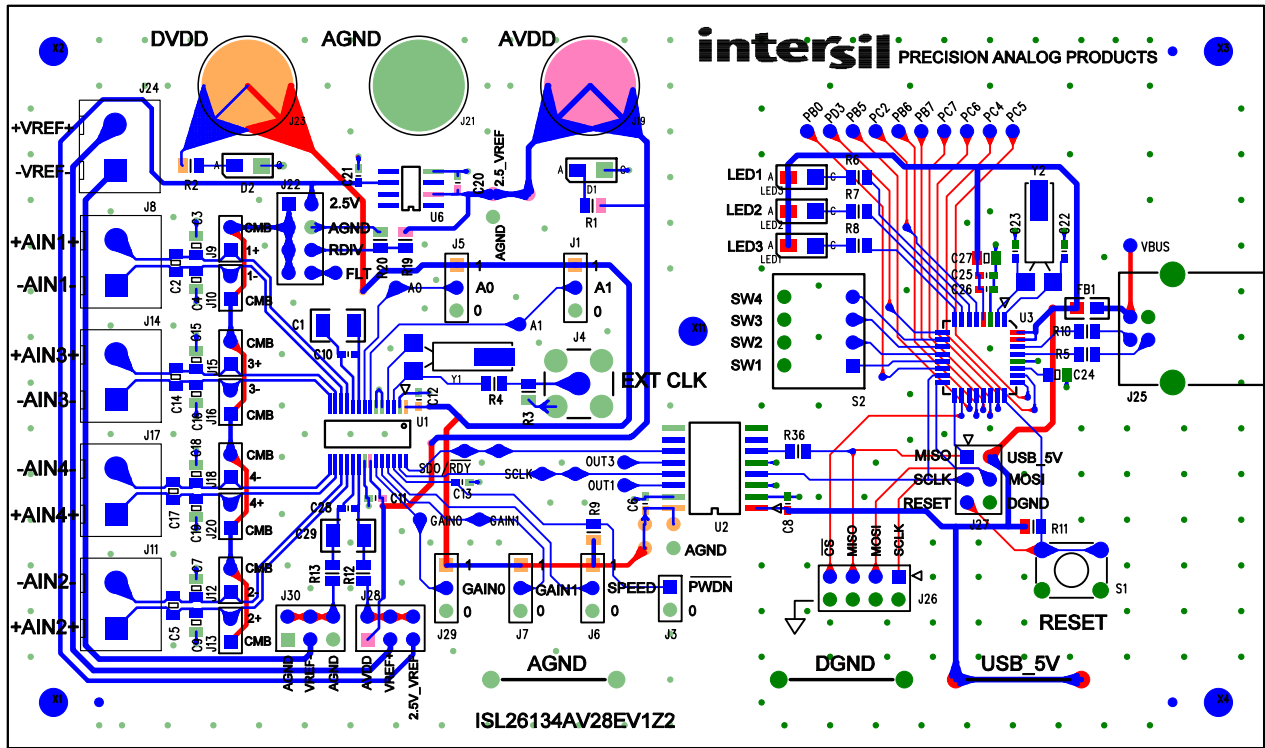

FIGURE 24. COMPOSITE OF LAYERS

Notice

1. Descriptions of circuits, software and other related information in this document are provided only to illustrate the operation of semiconductor products and application examples. You are fully responsible for the incorporation or any other use of the circuits, software, and information in the design of your product or system. Renesas Electronics disclaims any and all liability for any losses and damages incurred by you or third parties arising from the use of these circuits, software, or information.
2. Renesas Electronics hereby expressly disclaims any warranties against and liability for infringement or any other claims involving patents, copyrights, or other intellectual property rights of third parties, by or arising from the use of Renesas Electronics products or technical information described in this document, including but not limited to, the product data, drawings, charts, programs, algorithms, and application examples.
3. No license, express, implied or otherwise, is granted hereby under any patents, copyrights or other intellectual property rights of Renesas Electronics or others.
4. You shall not alter, modify, copy, or reverse engineer any Renesas Electronics product, whether in whole or in part. Renesas Electronics disclaims any and all liability for any losses or damages incurred by you or third parties arising from such alteration, modification, copying or reverse engineering.
5. Renesas Electronics products are classified according to the following two quality grades: "Standard" and "High Quality". The intended applications for each Renesas Electronics product depends on the product's quality grade, as indicated below.
"Standard": Computers; office equipment; communications equipment; test and measurement equipment; audio and visual equipment; home electronic appliances; machine tools; personal electronic equipment; industrial robots; etc.
"High Quality": Transportation equipment (automobiles, trains, ships, etc.); traffic control (traffic lights); large-scale communication equipment; key financial terminal systems; safety control equipment; etc.
Unless expressly designated as a high reliability product or a product for harsh environments in a Renesas Electronics data sheet or other Renesas Electronics document, Renesas Electronics products are not intended or authorized for use in products or systems that may pose a direct threat to human life or bodily injury (artificial life support devices or systems; surgical implantations; etc.), or may cause serious property damage (space system; undersea repeaters; nuclear power control systems; aircraft control systems; key plant systems; military equipment; etc.). Renesas Electronics disclaims any and all liability for any damages or losses incurred by you or any third parties arising from the use of any Renesas Electronics product that is inconsistent with any Renesas Electronics data sheet, user's manual or other Renesas Electronics document.
6. When using Renesas Electronics products, refer to the latest product information (data sheets, user's manuals, application notes, "General Notes for Handling and Using Semiconductor Devices" in the reliability handbook, etc.), and ensure that usage conditions are within the ranges specified by Renesas Electronics with respect to maximum ratings, operating power supply voltage range, heat dissipation characteristics, installation, etc. Renesas Electronics disclaims any and all liability for any malfunctions, failure or accident arising out of the use of Renesas Electronics products outside of such specified ranges.
7. Although Renesas Electronics endeavors to improve the quality and reliability of Renesas Electronics products, semiconductor products have specific characteristics, such as the occurrence of failure at a certain rate and malfunctions under certain use conditions. Unless designated as a high reliability product or a product for harsh environments in a Renesas Electronics data sheet or other Renesas Electronics document, Renesas Electronics products are not subject to radiation resistance design. You are responsible for implementing safety measures to guard against the possibility of bodily injury, injury or damage caused by fire, and/or danger to the public in the event of a failure or malfunction of Renesas Electronics products, such as safety design for hardware and software, including but not limited to redundancy, fire control and malfunction prevention, appropriate treatment for aging degradation or any other appropriate measures. Because the evaluation of microcomputer software alone is very difficult and impractical, you are responsible for evaluating the safety of the final products or systems manufactured by you.
8. Please contact a Renesas Electronics sales office for details as to environmental matters such as the environmental compatibility of each Renesas Electronics product. You are responsible for carefully and sufficiently investigating applicable laws and regulations that regulate the inclusion or use of controlled substances, including without limitation, the EU RoHS Directive, and using Renesas Electronics products in compliance with all these applicable laws and regulations. Renesas Electronics disclaims any and all liability for damages or losses occurring as a result of your noncompliance with applicable laws and regulations.
9. Renesas Electronics products and technologies shall not be used for or incorporated into any products or systems whose manufacture, use, or sale is prohibited under any applicable domestic or foreign laws or regulations. You shall comply with any applicable export control laws and regulations promulgated and administered by the governments of any countries asserting jurisdiction over the parties or transactions.
10. It is the responsibility of the buyer or distributor of Renesas Electronics products, or any other party who distributes, disposes of, or otherwise sells or transfers the product to a third party, to notify such third party in advance of the contents and conditions set forth in this document.
11. This document shall not be reprinted, reproduced or duplicated in any form, in whole or in part, without prior written consent of Renesas Electronics.
12. Please contact a Renesas Electronics sales office if you have any questions regarding the information contained in this document or Renesas Electronics products.
(Note 1) "Renesas Electronics" as used in this document means Renesas Electronics Corporation and also includes its directly or indirectly controlled subsidiaries.
(Note 2) "Renesas Electronics product(s)" means any product developed or manufactured by or for Renesas Electronics.

(Rev.4.0-1 November 2017)



SALES OFFICES

Renesas Electronics Corporation

<http://www.renesas.com>

Refer to "<http://www.renesas.com/>" for the latest and detailed information.

Renesas Electronics America Inc.
1001 Murphy Ranch Road, Milpitas, CA 95035, U.S.A.
Tel: +1-408-432-8888, Fax: +1-408-434-5351

Renesas Electronics Canada Limited
9251 Yonge Street, Suite 8309 Richmond Hill, Ontario Canada L4C 9T3
Tel: +1-905-237-2004

Renesas Electronics Europe Limited
Dukes Meadow, Millboard Road, Bourne End, Buckinghamshire, SL8 5FH, U.K
Tel: +44-1628-651-700, Fax: +44-1628-651-804

Renesas Electronics Europe GmbH
Arcadiastrasse 10, 40472 Düsseldorf, Germany
Tel: +49-211-6503-0, Fax: +49-211-6503-1327

Renesas Electronics (China) Co., Ltd.
Room 1709 Quantum Plaza, No.27 ZhichunLu, Haidian District, Beijing, 100191 P. R. China
Tel: +86-10-8235-1155, Fax: +86-10-8235-7679

Renesas Electronics (Shanghai) Co., Ltd.
Unit 301, Tower A, Central Towers, 555 Langao Road, Putuo District, Shanghai, 200333 P. R. China
Tel: +86-21-2226-0888, Fax: +86-21-2226-0999

Renesas Electronics Hong Kong Limited
Unit 1601-1611, 16/F., Tower 2, Grand Century Place, 193 Prince Edward Road West, Mongkok, Kowloon, Hong Kong
Tel: +852-2265-6688, Fax: +852-2886-9022

Renesas Electronics Taiwan Co., Ltd.
13F, No. 363, Fu Shing North Road, Taipei 10543, Taiwan
Tel: +886-2-8175-9600, Fax: +886-2-8175-9670

Renesas Electronics Singapore Pte. Ltd.
80 Bendemeer Road, Unit #06-02 Hyflux Innovation Centre, Singapore 339949
Tel: +65-6213-0200, Fax: +65-6213-0300

Renesas Electronics Malaysia Sdn.Bhd.
Unit 1207, Block B, Menara Amcorp, Amcorp Trade Centre, No. 18, Jln Persiaran Barat, 46050 Petaling Jaya, Selangor Darul Ehsan, Malaysia
Tel: +60-3-7955-9390, Fax: +60-3-7955-9510

Renesas Electronics India Pvt. Ltd.
No.777C, 100 Feet Road, HAL 2nd Stage, Indiranagar, Bangalore 560 038, India
Tel: +91-80-67208700, Fax: +91-80-67208777

Renesas Electronics Korea Co., Ltd.
17F, KAMCO Yangjae Tower, 262, Gangnam-daero, Gangnam-gu, Seoul, 06265 Korea
Tel: +82-2-558-3737, Fax: +82-2-558-5338



Компания «ЭлектроПласт» предлагает заключение долгосрочных отношений при поставках импортных электронных компонентов на взаимовыгодных условиях!

Наши преимущества:

- Оперативные поставки широкого спектра электронных компонентов отечественного и импортного производства напрямую от производителей и с крупнейших мировых складов;
- Поставка более 17-ти миллионов наименований электронных компонентов;
- Поставка сложных, дефицитных, либо снятых с производства позиций;
- Оперативные сроки поставки под заказ (от 5 рабочих дней);
- Экспресс доставка в любую точку России;
- Техническая поддержка проекта, помощь в подборе аналогов, поставка прототипов;
- Система менеджмента качества сертифицирована по Международному стандарту ISO 9001;
- Лицензия ФСБ на осуществление работ с использованием сведений, составляющих государственную тайну;
- Поставка специализированных компонентов (Xilinx, Altera, Analog Devices, Intersil, Interpoint, Microsemi, Aeroflex, Peregrine, Syfer, Eurofarad, Texas Instrument, Miteq, Cobham, E2V, MA-COM, Hittite, Mini-Circuits, General Dynamics и др.);

Помимо этого, одним из направлений компании «ЭлектроПласт» является направление «Источники питания». Мы предлагаем Вам помощь Конструкторского отдела:

- Подбор оптимального решения, техническое обоснование при выборе компонента;
- Подбор аналогов;
- Консультации по применению компонента;
- Поставка образцов и прототипов;
- Техническая поддержка проекта;
- Защита от снятия компонента с производства.



Как с нами связаться

Телефон: 8 (812) 309 58 32 (многоканальный)

Факс: 8 (812) 320-02-42

Электронная почта: org@eplast1.ru

Адрес: 198099, г. Санкт-Петербург, ул. Калинина, дом 2, корпус 4, литера А.