

Special function module - AXL CNT 2/INC 2 - 2688093

Please be informed that the data shown in this PDF Document is generated from our Online Catalog. Please find the complete data in the user's documentation. Our General Terms of Use for Downloads are valid (<http://phoenixcontact.com/download>)



Axioline special function module, 2 counter inputs, 2 incremental encoder inputs (including bus base module and connectors)

Product description

The module is designed for use within an Axioline station.

On the one hand, it is used to acquire fast pulse sequences from sensors, and on the other hand to detect positions using incremental encoders.

The module combines two counter inputs for the evaluation of fast counter pulses and two incremental encoder inputs for position detection.

Product Features

- 2 counter inputs
- 2 incremental encoder inputs
- Maximum input frequency: 300 kHz/100 kHz (depending on the wiring)
- 32-bit counter (up and down)
- Output control according to two limit values
- Counter: counting (source) is controlled via a control input (gate)
- Counter: single or periodic counting
- Incremental encoder acquisition: acquisition of digital signals from symmetrical and asymmetrical incremental encoders
- Incremental encoder acquisition: evaluation of linear or rotary axes
- Device rating plate stored
- Diagnostic and status indicators



Key commercial data

Packing unit	1 pc
Weight per Piece (excluding packing)	240.0 GRM
Custom tariff number	85389091
Country of origin	Germany

Technical data

Dimensions

Width	53.6 mm
-------	---------

Special function module - AXL CNT 2/INC 2 - 2688093

Technical data

Dimensions

Height	126.1 mm
Depth	54 mm
Note on dimensions	The depth is valid when a TH 35-7.5 DIN rail is used (according to EN 60715).

Ambient conditions

Ambient temperature (operation)	-25 °C ... 60 °C
Ambient temperature (storage/transport)	-40 °C ... 85 °C
Permissible humidity (operation)	5 % ... 95 % (non-condensing)
Permissible humidity (storage/transport)	5 % ... 95 % (non-condensing)
Air pressure (operation)	70 kPa ... 106 kPa (up to 3000 m above sea level)
Air pressure (storage/transport)	70 kPa ... 106 kPa (up to 3000 m above sea level)
Degree of protection	IP20

General

Weight	205 g
Note on weight specifications	with connectors and bus base module
Mounting type	DIN rail
Protection class	III, IEC 61140, EN 61140, VDE 0140-1
Test section	5 V communications power (logic), 24 V supply (I/O) 500 V AC 50 Hz 1 min
	5 V supply (logic)/functional earth ground 500 V AC 50 Hz 1 min
	24 V supply (I/O) / functional earth ground 500 V AC 50 Hz 1 min
Conformance with EMC directives	Noise immunity test in accordance with EN 61000-6-2 Electrostatic discharge (ESD) EN 61000-4-2/IEC 61000-4-2 Criterion B; 6 kV contact discharge, 8 kV air discharge
	Noise immunity test in accordance with EN 61000-6-2 Electromagnetic fields EN 61000-4-3/IEC 61000-4-3 Criterion A; Field intensity: 10 V/m
	Noise immunity test in accordance with EN 61000-6-2 Fast transients (burst) EN 61000-4-4/IEC 61000-4-4 Criterion B, 2 kV
	Noise immunity test in accordance with EN 61000-6-2 Transient surge voltage (surge) EN 61000-4-5/IEC 61000-4-5 Criterion B; DC supply lines: ±0.5 kV/±0.5 kV (symmetrical/asymmetrical)
	Noise immunity test in accordance with EN 61000-6-2 Conducted interference EN 61000-4-6/IEC 61000-4-6 Criterion A; Test voltage 10 V
	Noise emission test according to EN 61000-6-3 Radio interference properties EN 55022 Class B
Mechanical tests	Vibration resistance in acc. with EN 60068-2-6/IEC 60068-2-6 5g
	Shock in acc. with EN 60068-2-27/IEC 60068-2-27 30g
	Continuous shock according to EN 60068-2-27/IEC 60068-2-27 10g
Diagnostics messages	Short-circuit / overload of the digital outputs Yes
	Error at the symmetrical incremental encoder Yes

Special function module - AXL CNT 2/INC 2 - 2688093

Technical data

Interfaces

Designation	Axioline F local bus
Connection method	Bus base module
Transmission speed	100 MBit/s

Axioline potentials

Communications power U_{Bus}	5 V DC (via bus base module)
Current consumption from U_{Bus}	typ. 100 mA
	max. 120 mA
Supply of digital input modules U_i	24 V DC
Current consumption from U_i	typ. 50.5 mA (Own current consumption; without wiring of the terminal points)
	max. 2.5 A (dependent on the encoder or sensor type used and the load on the digital output.)

Counter inputs

Number of inputs	2 (S1, S2)
Description of the input	EN 61131-2, type 3
Connection method	Push-in technology
Input voltage	24 V DC
Input voltage range "0" signal	-3 V DC ... 5 V DC
Input voltage range "1" signal	11 V DC ... 30 V DC
Input frequency	max. 300 kHz (1 channel wired)
	max. 100 kHz (More than one channel wired or Z signal monitoring via the firmware)
Input current	2.5 mA (per channel)
Resolution	32
Permissible cable length to the sensor	30 m

Encoder inputs

Input name	Incremental encoder inputs
Number of inputs	2 (A1, /A1, B1, /B1, Z1, /Z1; A2, /A2, B2, /B2, Z2, /Z2)
Connection method	Push-in technology
Encoder signals	Symmetrical and asymmetrical encoders
Cable length	30 m

Encoder data

Number of 5 V encoder supplies	2 (U_{E1} , U_{E2})
Nominal output voltage	5 V DC
Voltage range	5 V DC ... 5.5 V DC
Current carrying capacity	max. 250 mA

Special function module - AXL CNT 2/INC 2 - 2688093

Technical data

Encoder data

Type of protection	Short-circuit protection
Protective circuit/component	Electronic
Number of 24 V encoder supplies	2 (U _{S1} , U _{S2})
Nominal output voltage	24 V DC
Voltage range	19.2 V DC ... 30 V DC
Current carrying capacity	typ. 500 mA
Type of protection	Short-circuit protection
Protective circuit/component	Electronic
Designation	Symmetrical incremental encoders
Encoder types that can be connected	max. 2 (A, /A, B, /B, (Z, /Z))
Type of connection of signals	Push-in technology
Encoder supply voltage	5 V DC
	24 V DC
Signal voltage level	Differential signal (signal – inverted signal) ±0.5 V, minimum; ±6 V, maximum
Common mode voltage range signal - ground	-10 V ... 13.2 V
Input frequency	max. 300 kHz (1 channel wired)
	max. 100 kHz (More than one channel wired or Z signal monitoring via the firmware)
Designation	Asymmetrical incremental encoders
Encoder types that can be connected	max. 2 (A, B, (Z))
Type of connection of signals	Push-in technology
Signal voltage level	Low ≤ 2.5 V, high ≥ 3.5 V (up to 27 V, maximum)
Input frequency	max. 300 kHz (1 channel wired)
	max. 100 kHz (More than one channel wired or Z signal monitoring via the firmware)

Digital inputs

Input name	Digital inputs
Description of the input	EN 61131-2, type 3
Connection method	Push-in technology
	1-wire (optionally 2, 3-wire)
Number of inputs	8 (CNT: G1, G2, Dir1, Dir2; INC: Ref1, Ref2, L1, L2)
Input voltage range "0" signal	-3 V DC ... 5 V DC
Input voltage range "1" signal	11 V DC ... 30 V DC
Nominal input current at U _{IN}	2.5 mA (per channel)

Digital outputs

Output name	Digital outputs
-------------	-----------------

Special function module - AXL CNT 2/INC 2 - 2688093

Technical data

Digital outputs

Connection method	Push-in technology
	1-wire
Number of outputs	2 (Out1, Out2)
Protective circuit	Short-circuit protection, overload protection of the outputs
Output voltage	24 V DC
Nominal output voltage	24 V DC
Maximum output current per channel	500 mA
Nominal load, inductive	max. 12 VA (1.2 H; 48 Ω; with nominal voltage)
Nominal load, lamp	max. 12 W (at nominal voltage)
Nominal load, ohmic	max. 12 W (48 Ω; with nominal voltage)

Classifications

eCl@ss

eCl@ss 4.0	27240409
eCl@ss 4.1	27240409
eCl@ss 5.0	27242205
eCl@ss 5.1	27242605
eCl@ss 6.0	27242605
eCl@ss 7.0	27242605
eCl@ss 8.0	27242605

ETIM

ETIM 4.0	EC001601
ETIM 5.0	EC001601

UNSPSC

UNSPSC 6.01	43172015
UNSPSC 7.0901	43201404
UNSPSC 11	39121311
UNSPSC 12.01	39121311
UNSPSC 13.2	39121311

Approvals

Approvals

Special function module - AXL CNT 2/INC 2 - 2688093

Approvals

Approvals

UL Listed / cUL Listed / BSH / RINA / DNV / cULus Listed

Ex Approvals

Approvals submitted

Approval details

UL Listed 

cUL Listed 

BSH

RINA

DNV

cULus Listed 

Drawings

Special function module - AXL CNT 2/INC 2 - 2688093

Connection diagram

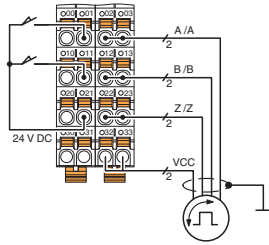

Dimensioned drawing

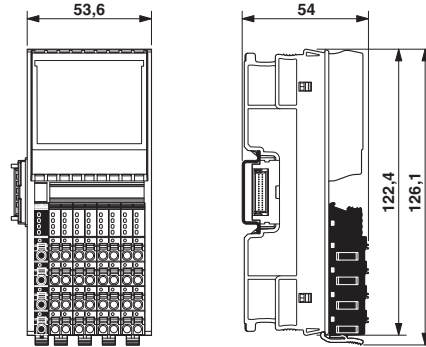

Block diagram

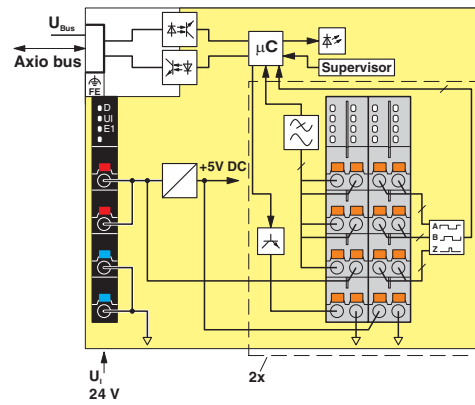

Internal wiring of the terminal points



Компания «ЭлектроПласт» предлагает заключение долгосрочных отношений при поставках импортных электронных компонентов на взаимовыгодных условиях!

Наши преимущества:

- Оперативные поставки широкого спектра электронных компонентов отечественного и импортного производства напрямую от производителей и с крупнейших мировых складов;
- Поставка более 17-ти миллионов наименований электронных компонентов;
- Поставка сложных, дефицитных, либо снятых с производства позиций;
- Оперативные сроки поставки под заказ (от 5 рабочих дней);
- Экспресс доставка в любую точку России;
- Техническая поддержка проекта, помощь в подборе аналогов, поставка прототипов;
- Система менеджмента качества сертифицирована по Международному стандарту ISO 9001;
- Лицензия ФСБ на осуществление работ с использованием сведений, составляющих государственную тайну;
- Поставка специализированных компонентов (Xilinx, Altera, Analog Devices, Intersil, Interpoint, Microsemi, Aeroflex, Peregrine, Syfer, Eurofarad, Texas Instrument, Miteq, Cobham, E2V, MA-COM, Hittite, Mini-Circuits, General Dynamics и др.);

Помимо этого, одним из направлений компании «ЭлектроПласт» является направление «Источники питания». Мы предлагаем Вам помощь Конструкторского отдела:

- Подбор оптимального решения, техническое обоснование при выборе компонента;
- Подбор аналогов;
- Консультации по применению компонента;
- Поставка образцов и прототипов;
- Техническая поддержка проекта;
- Защита от снятия компонента с производства.



Как с нами связаться

Телефон: 8 (812) 309 58 32 (многоканальный)

Факс: 8 (812) 320-02-42

Электронная почта: org@eplast1.ru

Адрес: 198099, г. Санкт-Петербург, ул. Калинина, дом 2, корпус 4, литера А.