

注記 NOTES

1. 使用材料 MATERIALS
 - ハウジング : 耐熱性樹脂(UL94V-0、ベージュ)
 - アクチュエータ : 耐熱性樹脂(UL94HB、黒色)
 - 奇数端子 : 銅合金、ニッケル下地、金メッキ
 - 偶数端子 : 銅合金、ニッケル下地、金メッキ
 - 補強金具 : 銅合金、ニッケル下地、スズメッキ
 - HOUSING : G.F. HEAT RESISTANCE PLASTIC (BEIGE)
 - ACTUATOR : G.F. HEAT RESISTANCE PLASTIC (BLACK)
 - ODD TERMINAL : COPPER ALLOY, Gold OVER Nickel PLATING
 - EVEN TERMINAL : COPPER ALLOY, Gold OVER Nickel PLATING
 - FITTING NAIL : COPPER ALLOY, Tin OVER Nickel PLATING
- △ 端子、補強金具のコプラナリティーは 0.1 以下とする
COPLANARITY OF SOLDER TAILS AND FITTING NAILS : 0.1MAX.
3. 一般公差: ±0.3
GENERAL TOLERANCES: ±0.3
- △ アクチュエータの図示箇所にゲート逃げの凹みがあります
THERE ARE DENT SHAPES AT ACTUATOR FOR MOLDING GATE
5. ELV 及び RoHS 適合品
ELV AND ROHS COMPLIANT
6. 塩素系・臭素系難燃剤非使用
CHLORINATED AND BROMINATED FLAME RETARDANTS FREE

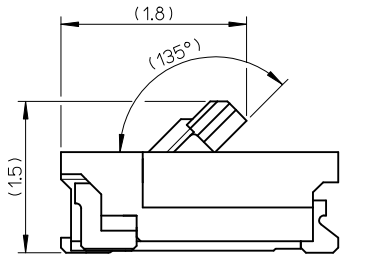

アクチュエータ開放位置
ACTUATOR OPENING POSITION

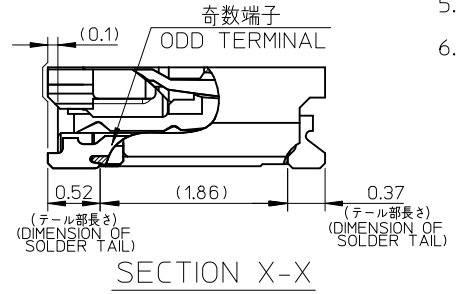
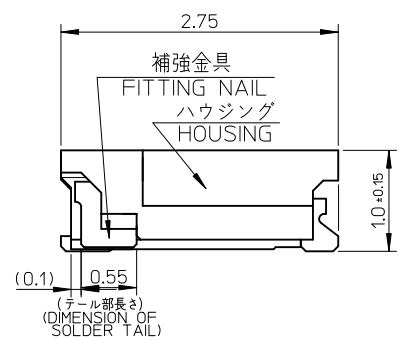
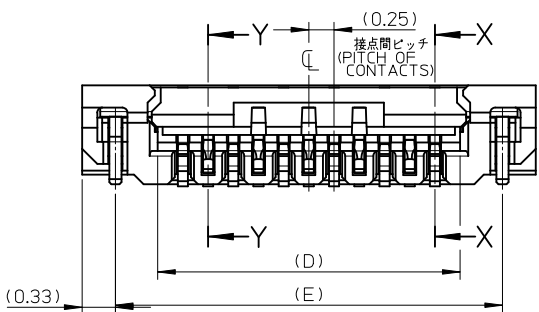
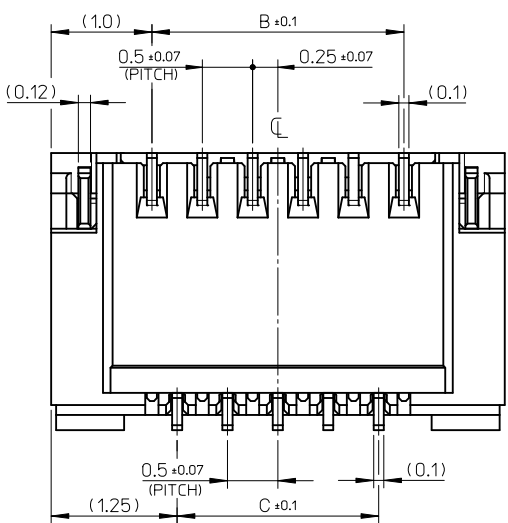

13.84	13	12	12.5	14.5	502078-5110	502078-5118	51
10.84	10	9	9.5	11.5	502078-3910	502078-3918	39
9.34	8.5	7.5	8	10	502078-3310	502078-3318	33
7.34	6.5	5.5	6	8	502078-2510	502078-2518	25
6.34	5.5	4.5	5	7	502078-2110	502078-2118	21
5.34	4.5	3.5	4	6	502078-1710	502078-1718	17
E	D	C	B	A	ORDER NO.	MATERIAL NO.	CKT.=N

REVISED EC NO: J2012-0409 DRAWN: TANAKA 2011/09/21 CHKD: APPR: SHOSHIKAWA 2011/09/30	DESCRIPTION	GENERAL TOLERANCES (UNLESS SPECIFIED)		DIMENSION STYLE	SCALE	DESIGN UNITS	THIRD ANGLE PROJECTION	
				MM ONLY	20:1	METRIC	◎ □	
		10 UNDER	± ---	DRAWN BY	DATE	TITLE		0.25 PITCH FPC CONN E/O HGT=1.0 BTM CONTACT TYPE
		10 OVER 30 UNDER	± ---	YFUJITA	2008/12/15			
30 OVER	± ---	CHECKED BY	DATE	MOLEX INCORPORATED		DOCUMENT NO. SD-502078-003		
ANGULAR	±1 °	TKANEKO	2008/12/15	MATERIAL NO.			SHEET NO. 1 OF 2	
DRAFT WHERE APPLICABLE MUST REMAIN WITHIN DIMENSIONS		SEE CHART		THIS DRAWING CONTAINS INFORMATION THAT IS PROPRIETARY TO MOLEX INCORPORATED AND SHOULD NOT BE USED WITHOUT WRITTEN PERMISSION				

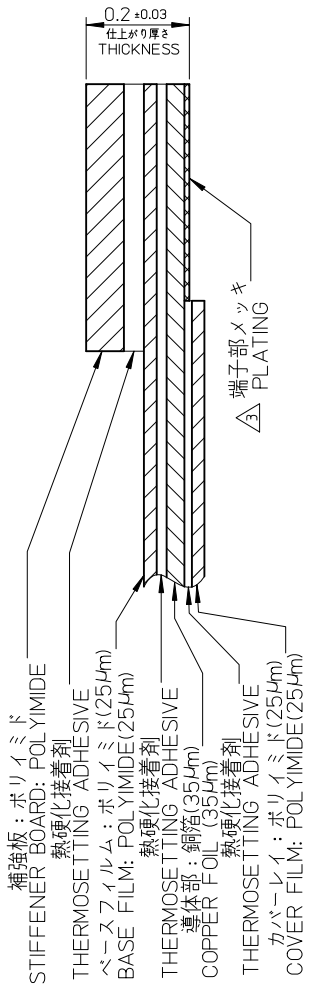

FPC 構成材料例
EXAMPLE OF FPC COMPOSITION MATERIAL

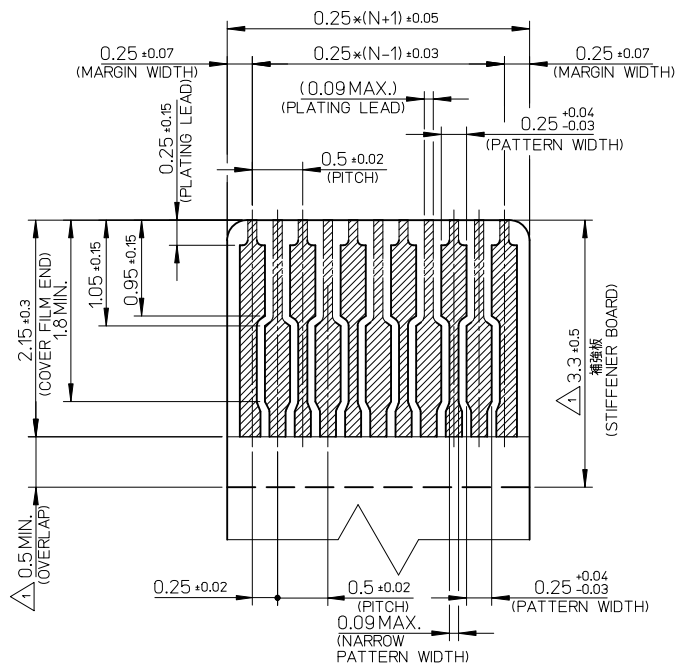

適合するFPC 推奨寸法
APPLICABLE FPC
RECOMMENDED DIMENSION

(端子部仕上がり厚さ: 0.2±0.03)
(THICKNESS: 0.2±0.03)

注記 NOTES

- 補強板長さが図面通り確保できない場合は、カバーレイと補強板のオーバーラップ寸法を 0.5mm 以上としてください
WHEN STIFFENER BOARD DIMENSION CAN NOT BE SECURED AS DRAWING, PLEASE GIVE THE OVERLAP SIZE OF COVER FILM AND STIFFENER BOARD AS 0.5mm MINIMUM
- 推奨ペースト厚 : 100μm
推奨マスク開口率 : 80%
RECOMMEND SCREEN THICKNESS : 100μm
RECOMMEND SCREEN OPEN RATIO : 80%

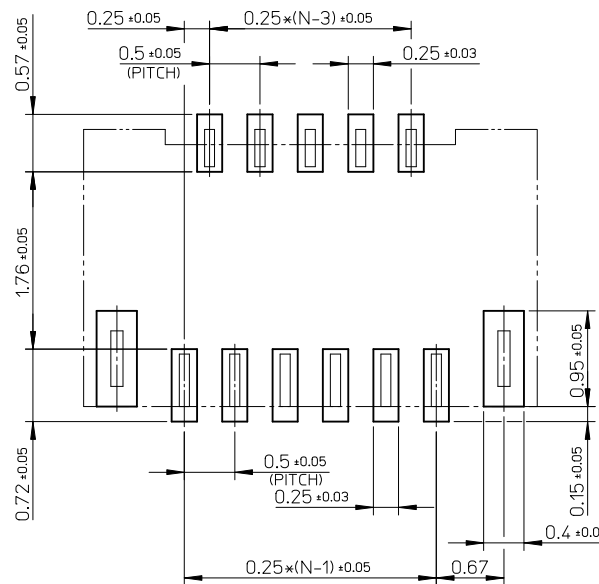

FPC挿入側
FPC INSERSION SIDE
参考基板レイアウト
RECOMMENDED PCB
PATTERN DIMENSIONS (REF.)

4 FPCについて (ABOUT FPC)

抜き方向は、導体側から補強板側を推奨します
補強板材質は、ポリイミドを推奨します
接着剤は熱硬化接着剤を推奨します
なお、接着剤の接点部への付着は導通不良の原因となりますので染み出しがないよう、お願いします
RECOMMENDED PUNCHER DIRECTION:
FROM CONDUCTOR SIDE TO STIFFENER BOARD SIDE
RECOMMENDED MATERIAL:
STIFFENER BOARD: POLYIMIDE
BONDING AGENT: THERMOSETTING AGENT
PLEASE PUT APPROPRIATE AMOUNT OF ADHESIVE ON THE CONTACT AREA BECAUSE THE EXTRA ADHESIVE MAY CAUSE THE DEFECT IN ELECTRICAL CONTINUITY

REVISED EC NO: J2012-04-09 DRAWN: TANAKA 2011/09/21 CHKD: APPR: SHOSHIKAWA 2011/09/30	GENERAL TOLERANCES (UNLESS SPECIFIED)		DIMENSION STYLE MM ONLY	SCALE 20:1	DESIGN UNITS METRIC	THIRD ANGLE PROJECTION
	10 UNDER	± ---	DRAWN BY YFUJITA	DATE 2008/12/15	TITLE 0.25 PITCH FPC CONN E/O HGT=1.0 BTM CONTACT TYPE	
	10 OVER 30 UNDER	± ---	CHECKED BY TKANEKO	DATE 2008/12/15	MOLEX INCORPORATED	
	30 OVER	± ---	APPROVED BY AHORINO	DATE 2008/12/15		
ANGULAR ±1 °	DRAFT WHERE APPLICABLE MUST REMAIN WITHIN DIMENSIONS	MATERIAL NO. SEE SHEET 1 OF 2	DOCUMENT NO. SD-502078-003	SHEET NO. 2 OF 2		
SIZE A3	THIS DRAWING CONTAINS INFORMATION THAT IS PROPRIETARY TO MOLEX INCORPORATED AND SHOULD NOT BE USED WITHOUT WRITTEN PERMISSION					

注記 NOTES

- 製品詳細寸法については図面 SD-502078-003 を参照下さい。
RE DETAILED DIMENSION, SEE SD-502078-003
- 梱包数量：3000 個/リール
NUMBER OF CONNECTORS : 3000 PCS/REEL
- リードテープ長さ LEAD TAPE LENGTH

引き出し方向
PULL OUT
DIRECTION

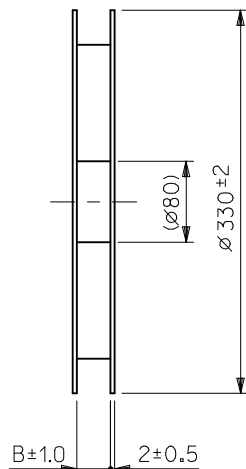
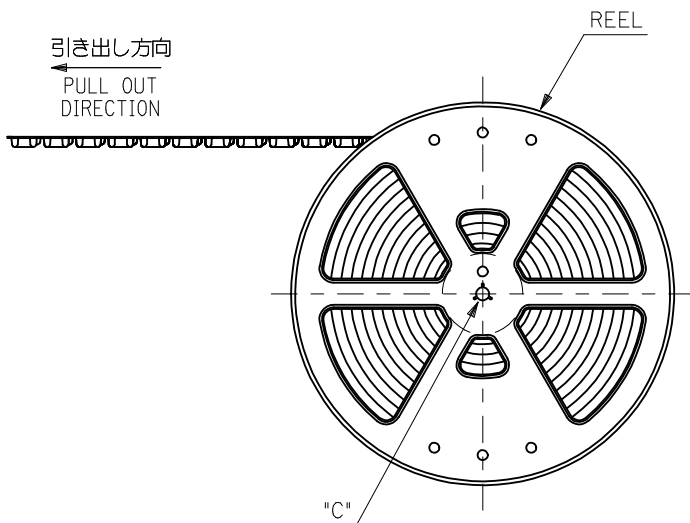

引き出し方向
PULL OUT
DIRECTION

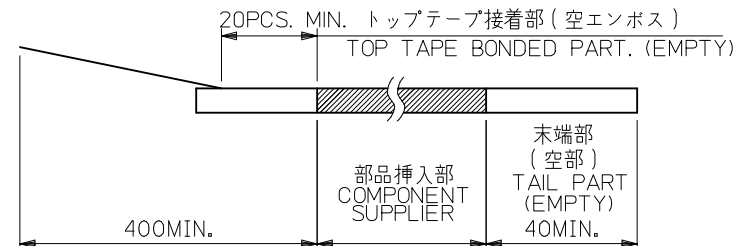

- 材料 MATERIAL
キャリアテープ (CARRIER TAPE) : ポリスチレン (POLYSTYRENE)
トップテープ (TOP TAPE) : PET, PE, PEF
リール (REEL) : ポリスチレン (PS) <リサイクル材を含む>
POLYSTYRENE (PS) <RECYCLE MATERIAL CONTAINED>

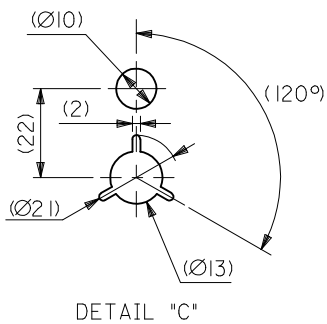

DETAIL "C"

RELEASED EC NO: J2009-1529 DRWN: YFUJITA 2008/12/15 CHKD: TKANEKO 2008/12/15 APPR: TKANEKO 2008/12/15	GENERAL TOLERANCES (UNLESS SPECIFIED)		DIMENSION STYLE MM ONLY		SCALE 1:1	DESIGN UNITS METRIC	MODEL NO. 502078-**10
	10 UNDER	±0.2	DRAWN BY YFUJITA	DATE 2008/12/15	TITLE 0.25 FPC CONN E/O HSG ASSY EMBOSSED TAPE PACKAGE		
	10 OVER 30 UNDER	±0.25	CHECKED BY TKANEKO	DATE 2008/12/15			
	30 OVER	±0.3	APPROVED BY AHORINO	DATE 2008/12/15	MOLEX INCORPORATED		
	ANGULAR ±1 °		MATERIAL NO. SEE CHART				
DRAFT WHERE APPLICABLE MUST REMAIN WITHIN DIMENSIONS		THIS DRAWING CONTAINS INFORMATION THAT IS PROPRIETARY TO MOLEX INCORPORATED AND SHOULD NOT BE USED WITHOUT WRITTEN PERMISSION					

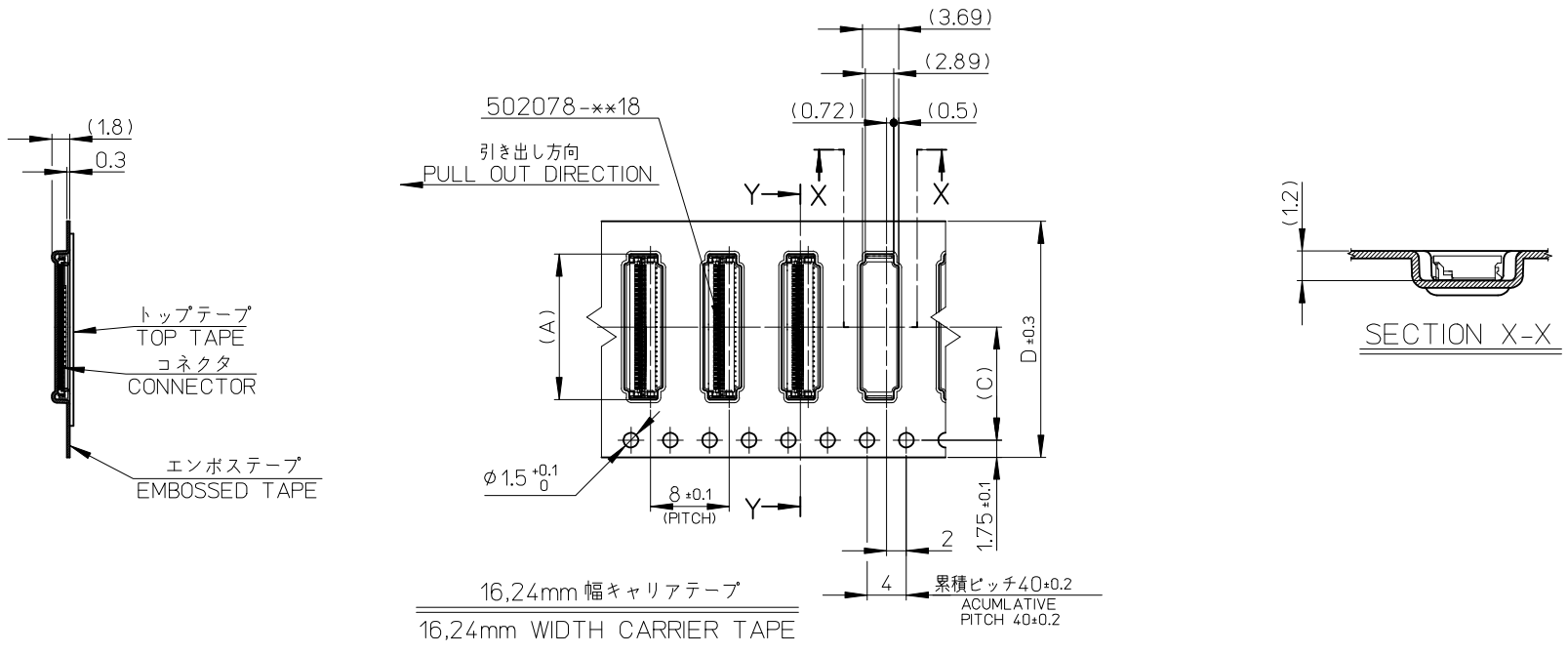

24	11.5	25.4	14.8	502078-5110	51
			11.8	502078-3910	39
			10.3	502078-3310	33
			8.3	502078-2510	25
			7.3	502078-2110	21
16	7.5	17.4	6.3	502078-1710	17
D キャリアテープ幅 CARRIER TAPE WIDTH	C	B	(A)	製品番号 MATERIAL NO.	極数 CKT.
MODEL NO.			502078-**-10		

RELEASED EC NO: J2009-1529 DRWN: YFUJITA 2008/12/15 CHKD: TKANEKO 2008/12/15 APPR: TKANEKO 2008/12/15 REV: 0	DESCRIPTION GENERAL TOLERANCES (UNLESS SPECIFIED) 10 UNDER ±0.2 10 OVER 30 UNDER ±0.25 30 OVER ±0.3 ANGULAR ±1 ° DRAFT WHERE APPLICABLE MUST REMAIN WITHIN DIMENSIONS	DIMENSION STYLE MM ONLY		SCALE	DESIGN UNITS	TITLE 0.25MM FPC CONN E/O HSG ASSY EMBOSSED TAPE PACKAGE MOLEX INCORPORATED DOCUMENT NO. SD-502078-004 SHEET NO. 2 OF 2	
		DRAWN BY DATE		1:1	METRIC		THIRD ANGLE PROJECTION
		YFUJITA 2008/12/15					
		CHECKED BY DATE					
		TKANEKO 2008/12/15					
APPROVED BY DATE							
AHORINO 2008/12/15							
MATERIAL NO.		SEE CHART					
SIZE		A3		THIS DRAWING CONTAINS INFORMATION THAT IS PROPRIETARY TO MOLEX INCORPORATED AND SHOULD NOT BE USED WITHOUT WRITTEN PERMISSION			



Компания «ЭлектроПласт» предлагает заключение долгосрочных отношений при поставках импортных электронных компонентов на взаимовыгодных условиях!

Наши преимущества:

- Оперативные поставки широкого спектра электронных компонентов отечественного и импортного производства напрямую от производителей и с крупнейших мировых складов;
- Поставка более 17-ти миллионов наименований электронных компонентов;
- Поставка сложных, дефицитных, либо снятых с производства позиций;
- Оперативные сроки поставки под заказ (от 5 рабочих дней);
- Экспресс доставка в любую точку России;
- Техническая поддержка проекта, помощь в подборе аналогов, поставка прототипов;
- Система менеджмента качества сертифицирована по Международному стандарту ISO 9001;
- Лицензия ФСБ на осуществление работ с использованием сведений, составляющих государственную тайну;
- Поставка специализированных компонентов (Xilinx, Altera, Analog Devices, Intersil, Interpoint, Microsemi, Aeroflex, Peregrine, Syfer, Eurofarad, Texas Instrument, Miteq, Cobham, E2V, MA-COM, Hittite, Mini-Circuits, General Dynamics и др.);

Помимо этого, одним из направлений компании «ЭлектроПласт» является направление «Источники питания». Мы предлагаем Вам помощь Конструкторского отдела:

- Подбор оптимального решения, техническое обоснование при выборе компонента;
- Подбор аналогов;
- Консультации по применению компонента;
- Поставка образцов и прототипов;
- Техническая поддержка проекта;
- Защита от снятия компонента с производства.



Как с нами связаться

Телефон: 8 (812) 309 58 32 (многоканальный)

Факс: 8 (812) 320-02-42

Электронная почта: org@eplast1.ru

Адрес: 198099, г. Санкт-Петербург, ул. Калинина, дом 2, корпус 4, литера А.