

## Preliminary Product Specification

### **32GFC RoHS Compliant Long Wavelength SFP+ Transceiver FTLF1432P3BCV**

#### PRODUCT FEATURES

- Up to 28.05 Gb/s bi-directional data links
- Hot-pluggable SFP+ footprint
- Built-in digital diagnostic functions
- 1310nm DFB laser transmitter
- Duplex LC connector
- RoHS compliant
- Up to 10 km on 9/125µm SMF
- Metal enclosure, for lower EMI
- 1.5W maximum power consumption with established link
- Single 3.3V power supply
- Operating temperature range:  
0°C to 70°C



#### APPLICATIONS

- Tri-Rate 8.5/14.025/28.05 Gb/s Fibre Channel

Finisar's FTLF1432P3BCV SFP+ transceivers are designed for use in Fibre Channel links up to 28.05 Gb/s data rate and upto 10km link length. They are compliant with FC-PI-6<sup>a</sup>, SFF-8472 Rev 12.1<sup>c</sup>, and compatible with SFF-8432<sup>b</sup> and applicable portions of SFF-8431 Rev. 4.1<sup>d</sup>. The optical transceiver is compliant per RoHS Directive 2011/65/EU<sup>e</sup>. See Finisar Application Note AN-2038 for more details.

#### PRODUCT SELECTION

**FTLF1432P3BCV**

## I. Pin Descriptions

Pin	Symbol	Name/Description	Ref.
1	V <sub>EET</sub>	Transmitter Ground (Common with Receiver Ground)	1
2	T <sub>FAULT</sub>	Transmitter Fault.	2
3	T <sub>DIS</sub>	Transmitter Disable. Laser output disabled on high or open.	3
4	SDA	2-wire Serial Interface Data Line (MOD-DEF2)	4
5	SCA	2-wire Serial Interface Clock (MOD-DEF1)	4
6	MOD_ABS	Module Absent, connected to V <sub>EET</sub> or V <sub>EER</sub>	4
7	RS0	Rx Rate Select: Open or Low = 8.5 or 14.025 Gb/s Fibre Channel (Low Bandwidth) High = 28.05 Gb/s Fibre Channel (High Bandwidth)	5
8	LOS	Loss of Signal indication. Logic 0 indicates normal operation.	6
9	RS1	Tx Rate Select: Open or Low = 8.5 or 14.025 Gb/s Fibre Channel (Low Bandwidth) High = 28.05 Gb/s Fibre Channel (High Bandwidth)	5
10	V <sub>EER</sub>	Receiver Ground (Common with Transmitter Ground)	1
11	V <sub>EER</sub>	Receiver Ground (Common with Transmitter Ground)	1
12	RD-	Receiver Inverted DATA out. AC Coupled	
13	RD+	Receiver Non-inverted DATA out. AC Coupled	
14	V <sub>EER</sub>	Receiver Ground (Common with Transmitter Ground)	1
15	V <sub>CCR</sub>	Receiver Power Supply	
16	V <sub>CCT</sub>	Transmitter Power Supply	
17	V <sub>EET</sub>	Transmitter Ground (Common with Receiver Ground)	1
18	TD+	Transmitter Non-Inverted DATA in. AC Coupled.	
19	TD-	Transmitter Inverted DATA in. AC Coupled.	
20	V <sub>EET</sub>	Transmitter Ground (Common with Receiver Ground)	1

### Notes:

- Circuit ground is internally isolated from chassis ground.
- T<sub>FAULT</sub> is an open collector/drain output, which should be pulled up with a 4.7k – 10k Ohms resistor on the host board if intended for use. Pull up voltage should be between 2.0V to V<sub>cc</sub> + 0.3V. A high output indicates a transmitter fault caused by either the TX bias current or the TX output power exceeding the preset alarm thresholds. A low output indicates normal operation. In the low state, the output is pulled to <0.8V.
- Laser output disabled on T<sub>DIS</sub> >2.0V or open, enabled on T<sub>DIS</sub> <0.8V.
- Should be pulled up with 4.7k – 10kohms on host board to a voltage between 2.0V and 3.6V. MOD\_ABS pulls line low to indicate module is plugged in.
- Rate select can also be set through the 2-wire bus in accordance with SFF-8472 v. 12.1°. Rx Rate Select is set at Bit 3, Byte 110, Address A2h. Tx Rate Select is set at Bit 3, Byte 118, Address A2h. Note: writing a “1” selects maximum bandwidth operation. Rate select is the logic OR of the input state of Rate Select Pin and 2-wire bus.
- LOS is open collector output. Should be pulled up with 4.7k – 10kohms on host board to a voltage between 2.0V and 3.6V. Logic 0 indicates normal operation; logic 1 indicates loss of signal.

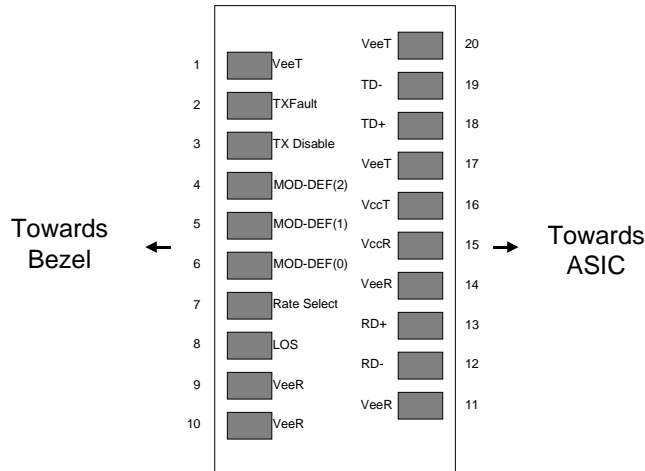

**Diagram of Host Board Connector Block Pin Numbers and Names**

## II. Absolute Maximum Ratings

Parameter	Symbol	Min	Typ	Max	Unit	Ref.
Maximum Supply Voltage	V <sub>CC</sub>	-0.5		4.0	V	
Storage Temperature	T <sub>S</sub>	-40		85	°C	
Case Operating Temperature	T <sub>C</sub>	0		70	°C	
Relative Humidity (Non-condensing)	RH	0		85	%	1

### Notes:

1. Non Condensing

## III. Electrical Characteristics (T<sub>A</sub>, V<sub>CC</sub> = 3.15 to 3.46 Volts)

Parameter	Symbol	Min	Typ	Max	Unit	Ref.
Supply Voltage	V <sub>CC</sub>	3.15		3.46	V	
Supply Current	I <sub>CC</sub>			400	mA	1
<b>Transmitter</b>						
Input differential impedance	R <sub>in</sub>		100		Ω	2
Differential data input eye height 28.05Gb/s 14.025Gb/s & 8.5Gb/s	V <sub>in,pp</sub>	250 180		900 700	mV	2
Inner Eye Height	EH6	50			mV	3
Transmit Disable Voltage	V <sub>D</sub>	2		V <sub>CC</sub>	V	4
Transmit Enable Voltage	V <sub>EN</sub>	V <sub>EE</sub>		V <sub>EE</sub> +0.8	V	
<b>Receiver</b>						
Single ended data output swing	V <sub>out,pp</sub>	185		425	mV	5
LOS Fault	V <sub>LOS fault</sub>	2		V <sub>CC</sub> HOST	V	6
LOS Normal	V <sub>LOS norm</sub>	V <sub>EE</sub>		V <sub>EE</sub> +0.8	V	6
Power Supply Rejection	PSR	100			mV <sub>pp</sub>	7

### Notes:

1. With established link, the total power dissipation shall not exceed 1.3W.
2. Connected directly to TX data input pins. AC coupling from pins into CDR, BER contour 10<sup>-6</sup>, per FC-PI 6 and FC-MSQS-2.
3. Inner eye height (EH6) for high loss case
4. Or open circuit.
5. Into 100 ohms differential termination.
6. LOS is an open collector output. Should be pulled up with 4.7k – 10kohms on the host board. Normal operation is logic 0; loss of signal is logic 1. Maximum pull-up voltage is 5.5V.
7. Receiver sensitivity is compliant with power supply sinusoidal modulation of 20 Hz to 1.5 MHz up to specified value applied through the recommended power supply filtering network.

#### IV. Optical Characteristics ( $T_A$ , $V_{CC} = 3.15$ to $3.46$ Volts)

Parameter	Symbol	Min	Typ	Max	Unit	Ref.
<b>Transmitter</b>						
Average Output Power, 28.05Gb/s & 14.025G/s	$P_{OUT}$	-5		+2.0	dBm	1,2
Average Output Power, 8.5Gb/s	$P_{OUT}$	-8.4		+2.0	dBm	1
Optical Wavelength	$\lambda$	1295		1325	nm	
Spectral Width (-20dB)	$\sigma$			1	nm	
Side Mode Suppression Ratio		30			dB	
Optical Modulation Amplitude 8.5 Gb/s 14.025Gb/s 28.05Gb/s	OMA	290 (-5.4) 631 (-2.0) 631 (-2.0)		(+3)	$\mu$ W(dBm)	
Transmitter Dispersion Penalty @ 8.5 Gb/s 14.025Gb/s 28.05Gb/s	TDP			3.2 4.4 2.7	dB	
Extinction Ratio 8.5Gb/s & 14.025Gb/s 28.05Gb/s	ER	3.5 4			dB	
Relative Intensity Noise 28.05Gb/s & 14.025Gb/s 8.5Gb/s	RIN			-130 -128	dB/Hz	
<b>Receiver</b>						
Unstressed Receiver OMA Sensitivity 8.5 Gb/s 14.025Gb/s 28.05Gb/s	RxSENS			42 (-13.8) 63 (-12.0) 72(-11.4)	$\mu$ W(dBm)	3
Average Receiver Power	$R_{XMAX}$			2	dBm	
Optical Return Loss 8.5Gb/s & 14.025Gb/s 28.05Gb/s		12 26			dB	
LOS De-Assert	$LOS_D$			-17	dBm	
LOS Assert	$LOS_A$	-30			dBm	
LOS Hysteresis		0.5			dB	

Notes:

1. Class 1 Laser Safety limit per FDA/CDRH, and EN (IEC) 60825 laser safety standards.
2. 3200-SM-LC-L OMA in dBm shall also exceed -5.0 TDP.
3. For 32GFC with FEC, receiver sensitivity is defined at  $10^{-6}$  BER level, not  $10^{-12}$  BER level.

#### IV. General Specifications

Parameter	Symbol	Min	Typ	Max	Units	Ref.
Data Rate	BR		8.5 14.025 28.05		Gb/sec	1
Bit Error Rate	BER			$10^{-12}$ $10^{-6}$		2 3
Fiber Length	L			10	km	

##### Notes:

1. 8x, 16x and 32x Fibre Channel compatible, per FC-PI-5<sup>a</sup>., FC-PI-6<sup>a</sup> respectively
2. PRBS 2<sup>7</sup>-1 for 8GFC. PRBS 2<sup>31</sup>-1 for 16GFC
3. FEC for 32GFC

#### VI. Environmental Specifications

Parameter	Symbol	Min	Typ	Max	Units	Ref.
Case Operating Temperature	T <sub>op</sub>	0		85	°C	
Storage Temperature	T <sub>sto</sub>	-40		85	°C	

#### VII. Regulatory Compliance

Finisar transceivers are Class 1 Laser Products and comply with US FDA regulations. These products are certified by TÜV and CSA to meet the Class 1 eye safety requirements of EN (IEC) 60825 and the electrical safety requirements of EN (IEC) 60950. Copies of certificates are available at Finisar Corporation upon request.

### **VIII. Digital Diagnostic Functions**

Finisar FTLF1432P3BCV SFP+ transceivers support the 2-wire serial communication protocol as defined in the SFP MSA<sup>f</sup>. It is very closely related to the E<sup>2</sup>PROM defined in the GBIC standard, with the same electrical specifications.

The standard SFP serial ID provides access to identification information that describes the transceiver's capabilities, standard interfaces, manufacturer, and other information.

Additionally, Finisar SFP transceivers provide an enhanced digital diagnostic monitoring interface, which allows real-time access to device operating parameters such as transceiver temperature, laser bias current, transmitted optical power, received optical power and transceiver supply voltage. It also defines a sophisticated system of alarm and warning flags, which alerts end-users when particular operating parameters are outside of a factory set normal range.

The SFP MSA defines a 256-byte memory map in E<sup>2</sup>PROM that is accessible over a 2-wire serial interface at the 8 bit address 1010000X (A0h). The digital diagnostic monitoring interface makes use of the 8 bit address 1010001X (A2h), so the originally defined serial ID memory map remains unchanged. The interface is identical to, and is thus fully backward compatible with both the GBIC Specification and the SFP Multi Source Agreement. The complete interface is described in Finisar Application Note AN-2030: "Digital Diagnostics Monitoring Interface for SFP Optical Transceivers".

The operating and diagnostics information is monitored and reported by a Digital Diagnostics Transceiver Controller (DDTC) inside the transceiver, which is accessed through a 2-wire serial interface. When the serial protocol is activated, the serial clock signal (SCL, Mod Def 1) is generated by the host. The positive edge clocks data into the SFP transceiver into those segments of the E<sup>2</sup>PROM that are not write-protected. The negative edge clocks data from the SFP transceiver. The serial data signal (SDA, Mod Def 2) is bi-directional for serial data transfer. The host uses SDA in conjunction with SCL to mark the start and end of serial protocol activation. The memories are organized as a series of 8-bit data words that can be addressed individually or sequentially.

For more information, please see the SFP MSA documentation<sup>e,f</sup> and Finisar Application Note AN-2030.

## IX. Digital Diagnostic Specifications

FTLF1432P3BCV transceivers can be used in host systems that require either internally or externally calibrated digital diagnostics.

Parameter	Symbol	Units	Min	Max	Accuracy	Ref.
Transceiver temperature	DDDTemp	°C	0	+70	±5°C	
Transceiver supply voltage	DDDVoltage	V	3.14	3.45	±3%	
Transmitter bias current	DDBBias	mA	0	50	±10%	1
Transmitter output power	DDDTx-Power	dBm	-9	+2	±3dB	
Receiver average optical input power	DDDRx-Power	dBm	-12	2	±3dB	

Notes:

1. Accuracy of Measured Tx Bias Current is 10% of the actual Bias Current from the laser driver to the laser.



### X. Mechanical Specifications

Finisar's FTLF1432P3BCV SFP+ transceivers are compatible with the SFF-8432<sup>b</sup> specification for improved pluggable form factor.

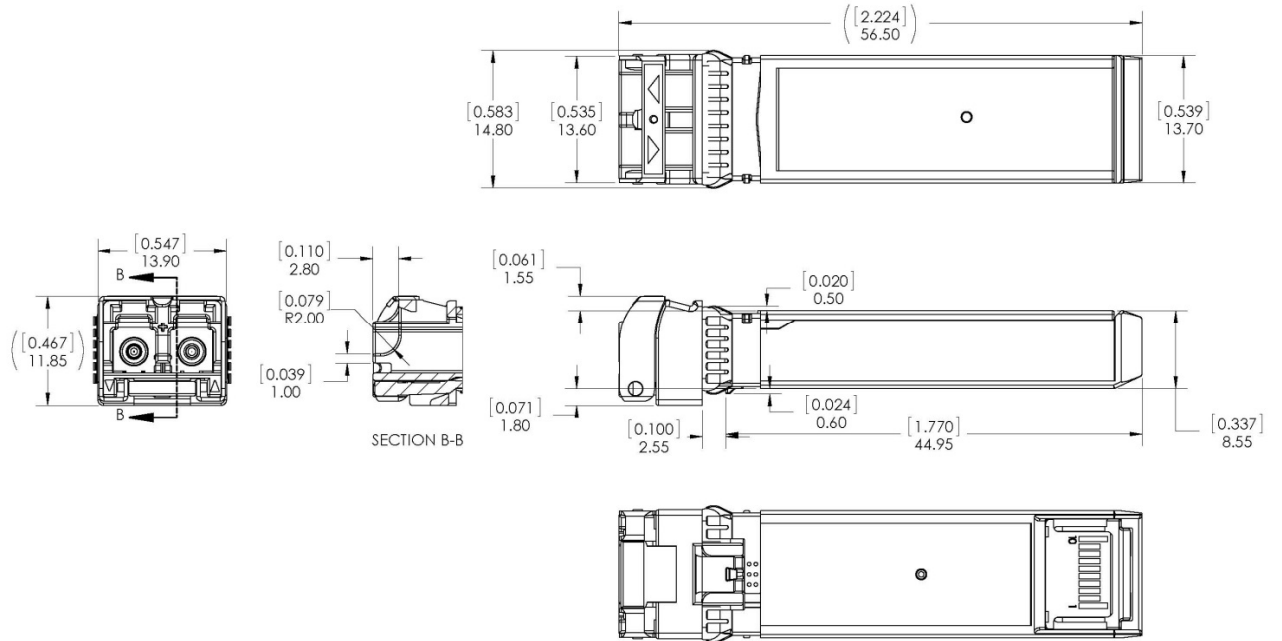

## FTLF1432P3BCV

### XI. PCB Layout and Bezel Recommendations

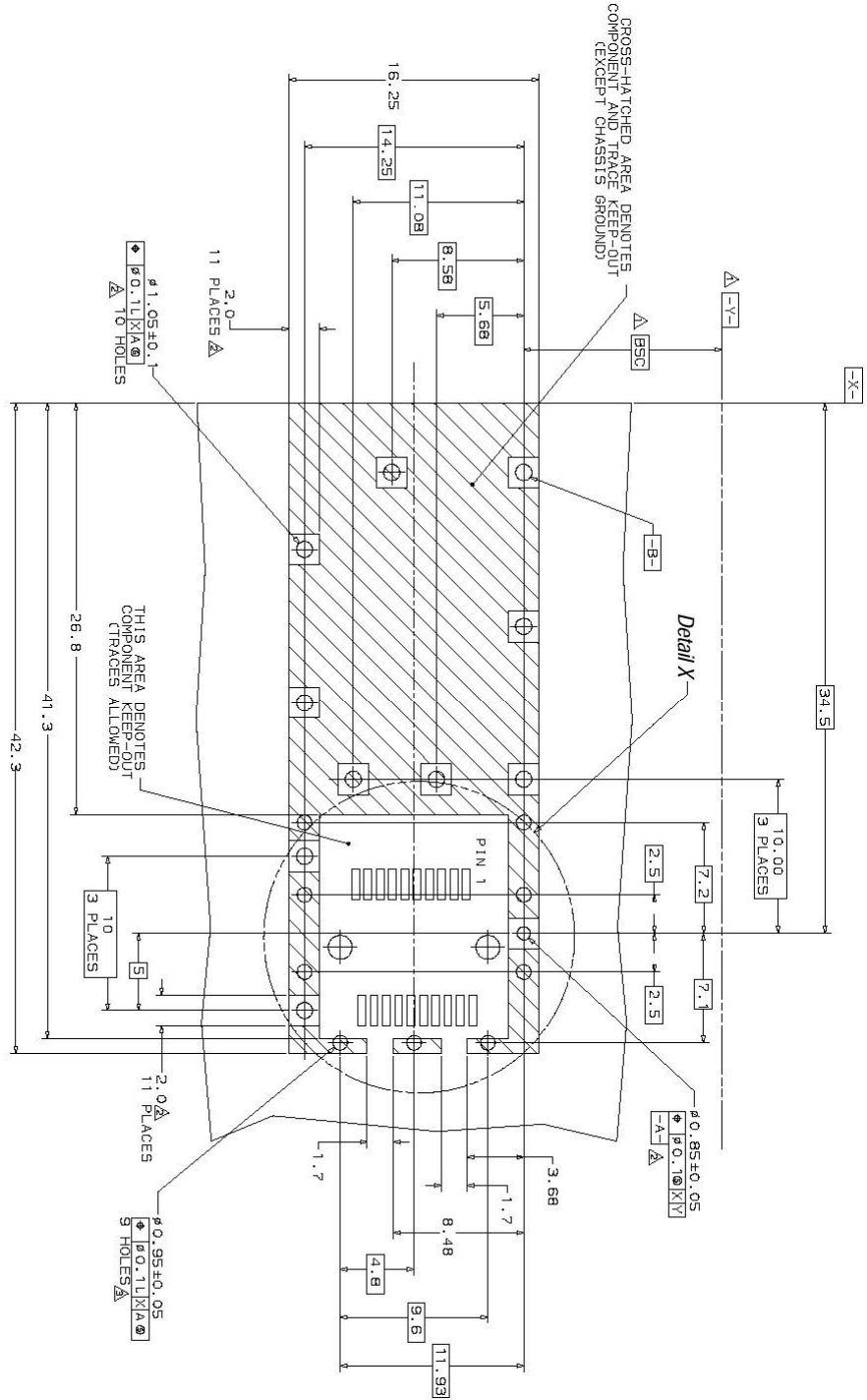

- △ Datum and Basic Dimension Established by Customer
- ⊕ Pads and Vias are Chassis Ground, 11 Places
- ⊖ Through Holes are Unplated

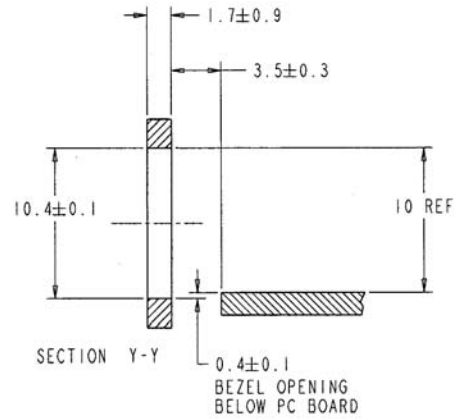
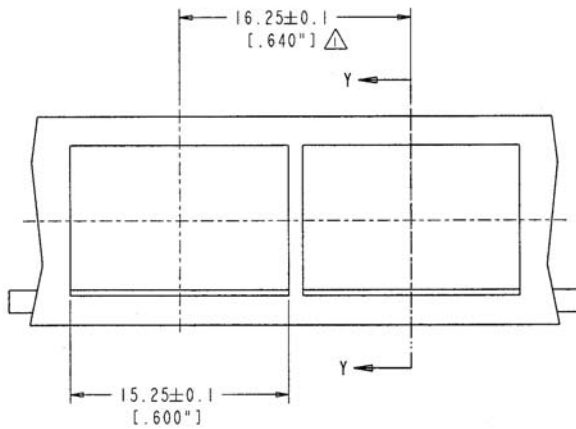
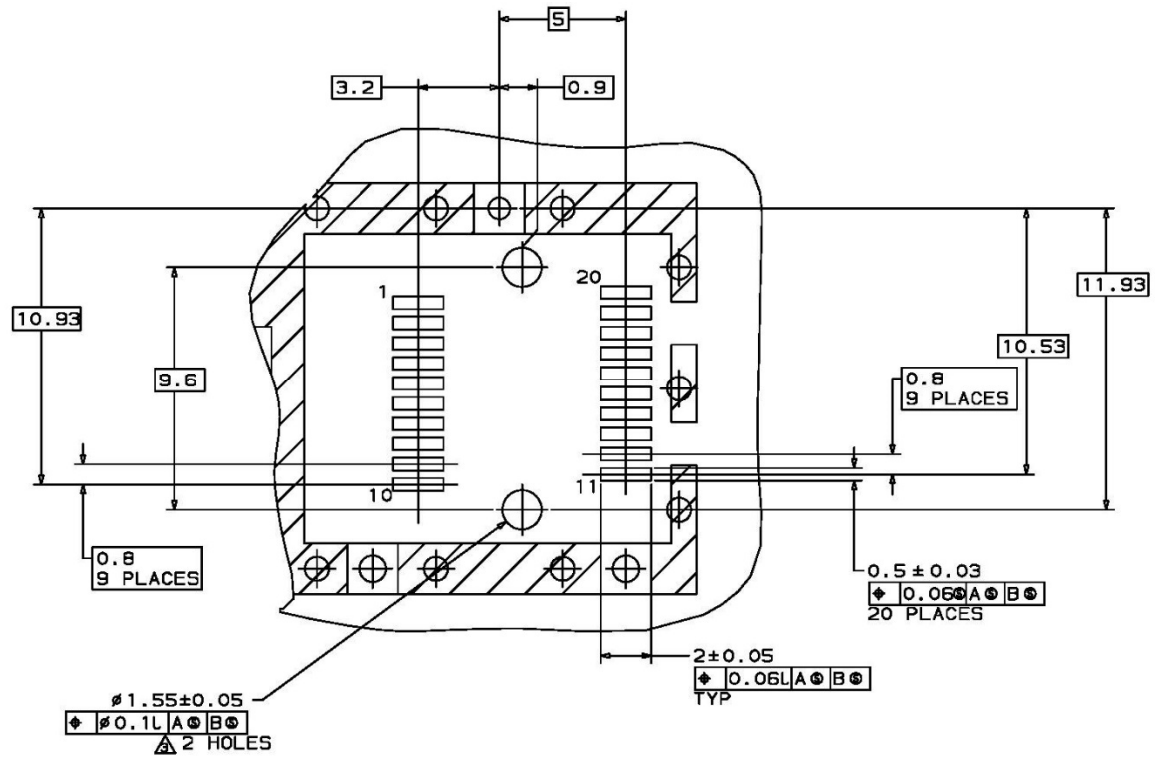

NOTES:

△ MINIMUM PITCH ILLUSTRATED, ENGLISH DIMENSIONS ARE FOR REFERENCE ONLY

2. NOT RECOMMENDED FOR PCI EXPANSION CARD APPLICATIONS

**XII. References**

- a. “Fibre Channel – Physical Interfaces -5, INCITS 479-2011 (*Defines 8GFC and 16GFC*)  
Fibre Channel – Physical Interfaces -6, INCITS 512-2014 (*Defines 32GFC*)”
- b. “Improved Pluggable Form Factor”, SFF Document Number SFF-8432, Revision 5.0, July 16, 2007.
- c. “Digital Monitoring Interface for Optical Transceivers”, SFF Document Number SFF-8472, Revision 12.1.
- d. “Enhanced Small Form Factor Pluggable Module ‘SFP+ ’”, SFF Document Number SFF-8431, Revision 4.1, July 6, 2009; Addendum Jun 21, 2013.
- e. Directive 2011/65/EU of the European Council Parliament and of the Council, “on the restriction of the use of certain hazardous substances in electrical and electronic equipment”. 08-June 2011, which supercedes the previous ROHS Directive 2002/95/EC.
- f. Small Form Factor Pluggable (SFP) Transceiver Multi-source Agreement (MSA), September 14, 2000 which is available as SFF Document Number INF-8074, Revision 1.0 May 12, 2001
- g. “0.8mm Card Edge Connector for 16Gb/s Applications”, SFF Document Number SFF-8081, Revision 0.2, December 21, 2009.
- h. SFF-8402, Revision 0.2

**XIII. For More Information**

Finisar Corporation  
1308 Moffett Park Drive  
Sunnyvale, CA 94089-1133  
Tel. 1-408-548-1000  
Fax 1-408-541-6138  
[sales@finisar.com](mailto:sales@finisar.com)  
[www.finisar.com](http://www.finisar.com)



Компания «ЭлектроПласт» предлагает заключение долгосрочных отношений при поставках импортных электронных компонентов на взаимовыгодных условиях!

Наши преимущества:

- Оперативные поставки широкого спектра электронных компонентов отечественного и импортного производства напрямую от производителей и с крупнейших мировых складов;
- Поставка более 17-ти миллионов наименований электронных компонентов;
- Поставка сложных, дефицитных, либо снятых с производства позиций;
- Оперативные сроки поставки под заказ (от 5 рабочих дней);
- Экспресс доставка в любую точку России;
- Техническая поддержка проекта, помощь в подборе аналогов, поставка прототипов;
- Система менеджмента качества сертифицирована по Международному стандарту ISO 9001;
- Лицензия ФСБ на осуществление работ с использованием сведений, составляющих государственную тайну;
- Поставка специализированных компонентов (Xilinx, Altera, Analog Devices, Intersil, Interpoint, Microsemi, Aeroflex, Peregrine, Syfer, Eurofarad, Texas Instrument, Miteq, Cobham, E2V, MA-COM, Hittite, Mini-Circuits, General Dynamics и др.);

Помимо этого, одним из направлений компании «ЭлектроПласт» является направление «Источники питания». Мы предлагаем Вам помощь Конструкторского отдела:

- Подбор оптимального решения, техническое обоснование при выборе компонента;
- Подбор аналогов;
- Консультации по применению компонента;
- Поставка образцов и прототипов;
- Техническая поддержка проекта;
- Защита от снятия компонента с производства.



#### Как с нами связаться

**Телефон:** 8 (812) 309 58 32 (многоканальный)

**Факс:** 8 (812) 320-02-42

**Электронная почта:** [org@eplast1.ru](mailto:org@eplast1.ru)

**Адрес:** 198099, г. Санкт-Петербург, ул. Калинина, дом 2, корпус 4, литера А.