

NCP81295, NCP81296

Hot Swap Smart Fuse

The NCP81295 and NCP81296 are 50 A, electronically re-settable, in-line fuses for use in 12 V, high current applications such as servers, storage and base stations. The NCP81295/6 offers a very low 0.65 mΩ integrated MOSFET to reduce solution size and minimize power loss. It also integrates a highly accurate current sensor for monitoring and overload protection.

Power Features

- Co-packaged Power Switch, Hotswap Controller and Current Sense
- Up to 60 A Peak Current Output, 50 A Continuous
- Vin Range: 4.5 V to 18 V
- 0.65 mΩ, no R_{SENSE} Required

Control Features

- Enable Input
- Optional Enable-controlled Output Pulldown when Disabled
- Programmable Soft-Start
- Programmable, Multi-level Current Limit

Reporting Features

- Accurate Analog Load Current Monitor
- Programmable Over Current Alert Output
- Analog Temperature Output
- Status Fault OK Output

Other Features

- 5 mm x 5 mm QFN32 Package
- Operating Temperature: -40°C to 125°C
- Can be Paralleled for Higher Current Applications
- Built-in Insertion Delay for Hotswap Applications
- NCP81295: Latch off for Following Protection Features
- NCP81296: Auto-Retry Mode for Following Protection Features
 - ◆ Current-limit after Delay
 - ◆ Fast Short-circuit Protection
 - ◆ Over-Temperature Shutdown
 - ◆ Excessive Soft-start Duration
- Internal Switch Fault Diagnostics
- Low-power Auxiliary Output Voltage



ON Semiconductor®

www.onsemi.com

MARKING DIAGRAM

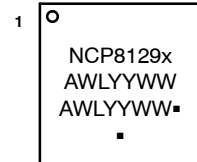
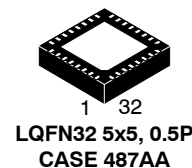

NCP8129x = Specific Device Code

x = 5 or 6

A = Assembly Location

WL = Wafer Lot

YY = Year

WW = Work Week

▪ = Pb-Free Package
(may or may not be present)

(Note: Microdot may be in either location)

PINOUT

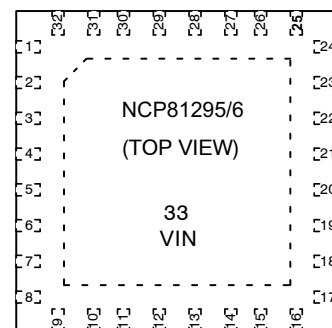

For more details see Figure 1.

ORDERING INFORMATION

See detailed ordering and shipping information on page 2 of this data sheet.

NCP81295, NCP81296

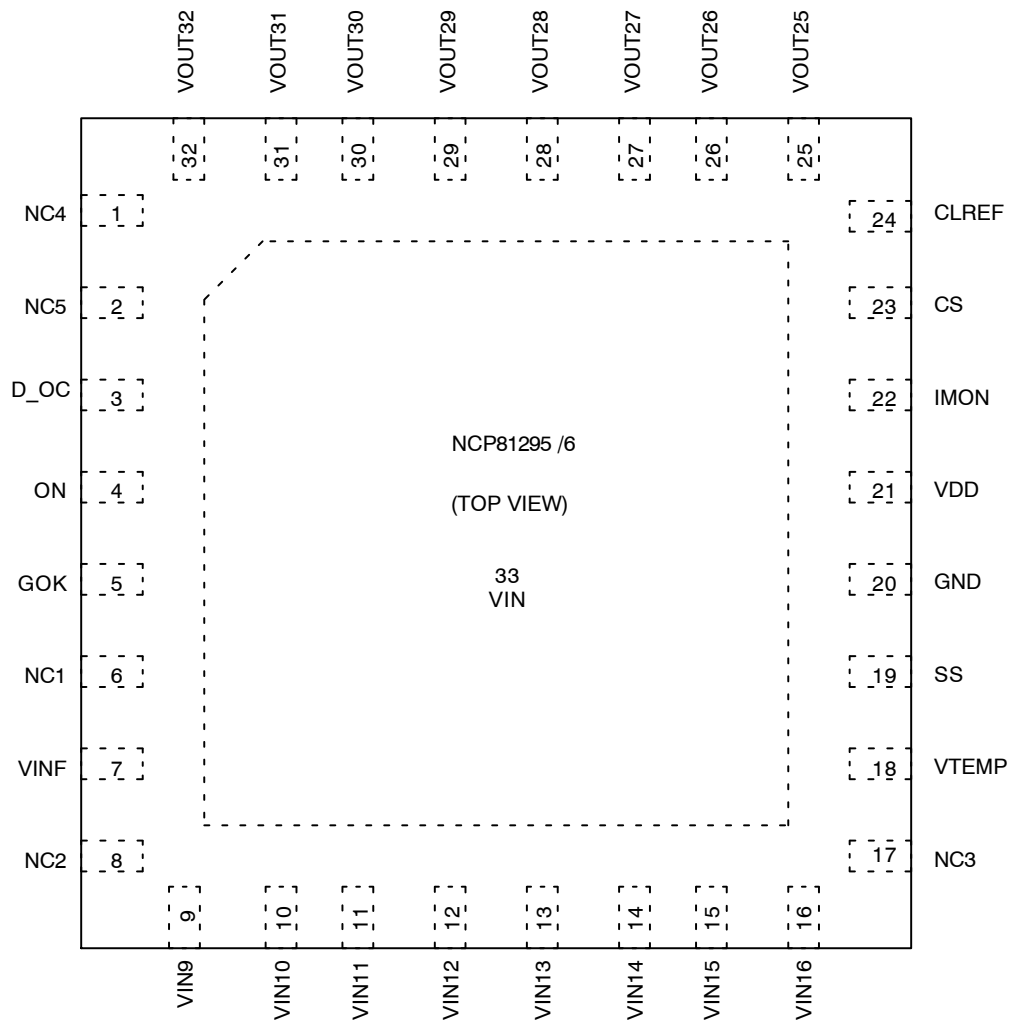

Figure 1. Pin Configuration

Ordering Information

Table 1. AVAILABLE DEVICES

Device	Package	Shipping [†]
NCP81295MNTXG	QFN32	2500/Tape & Reel
NCP81296MNTXG	QFN32	2500/Tape & Reel

[†]For information on tape and reel specifications, including part orientation and tape sizes, please refer to our Tape and Reel Packaging Specifications Brochure, BRD8011/D.

NCP81295, NCP81296

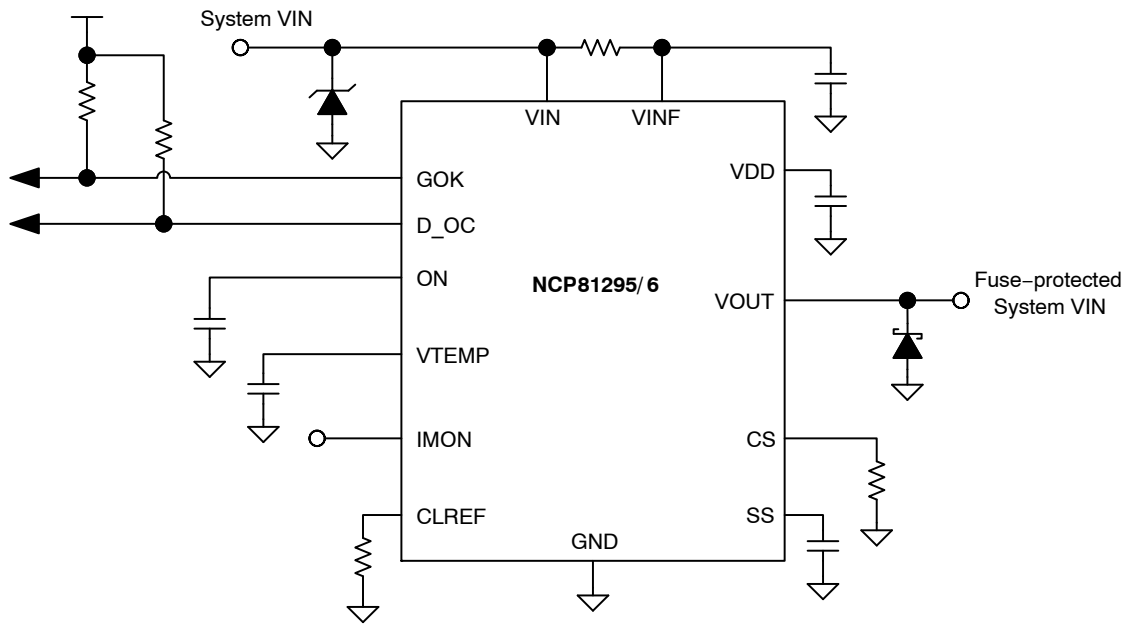

Figure 2. Typical Application

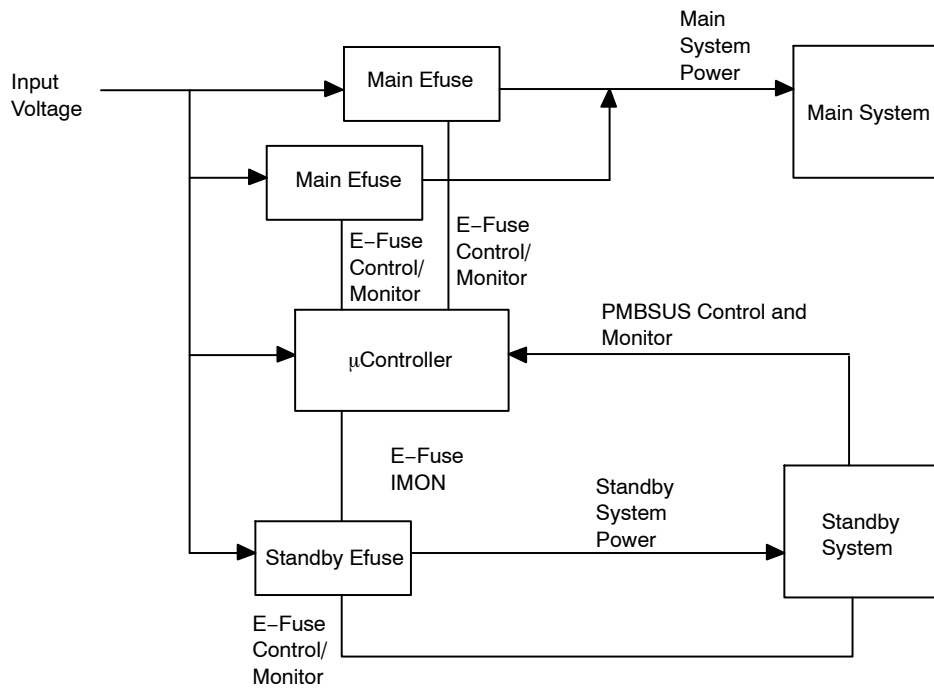

Figure 3. Typical Application Diagram

NCP81295, NCP81296

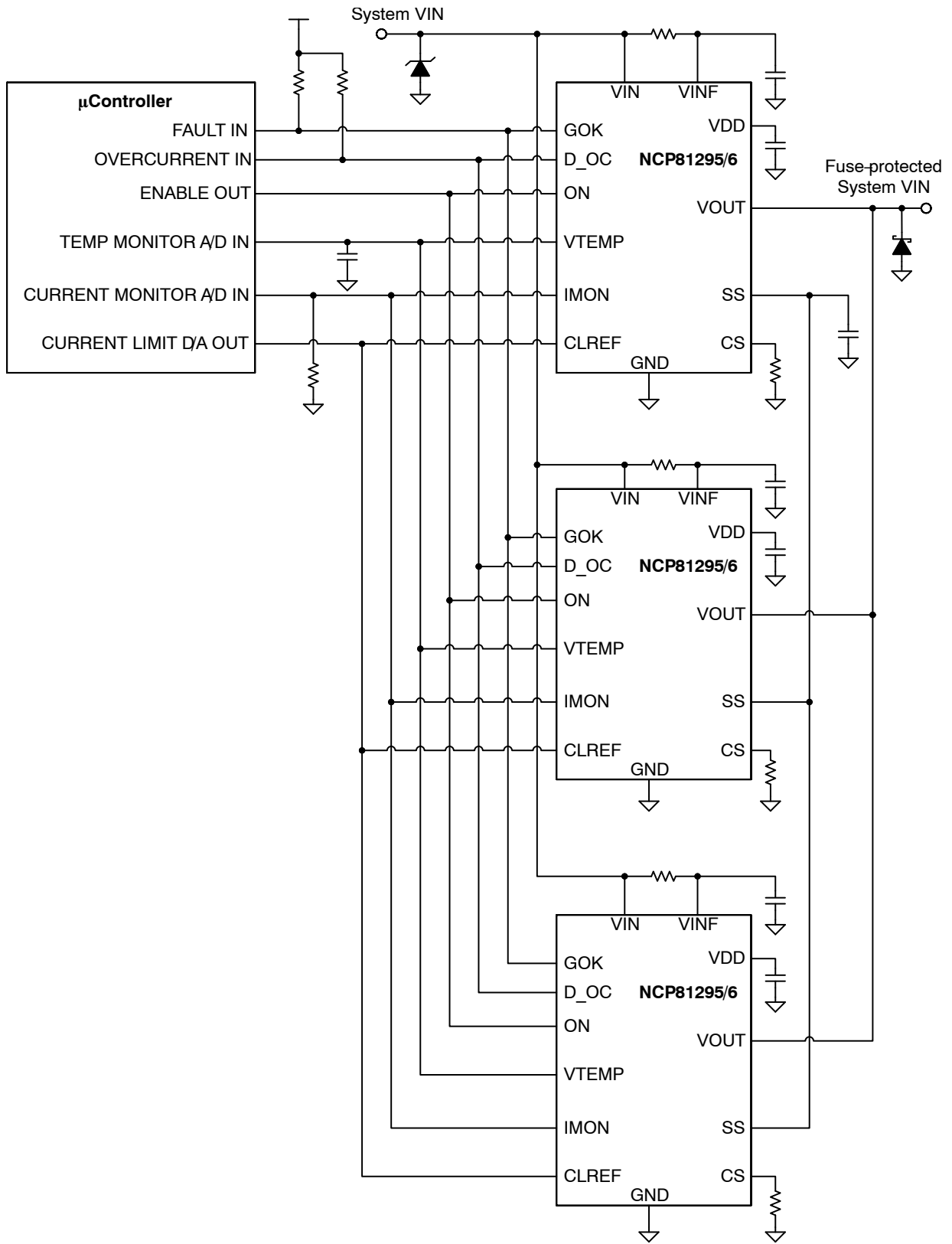

Figure 4. Application Schematic – Parallel Fuse Operation with Controller

NCP81295, NCP81296

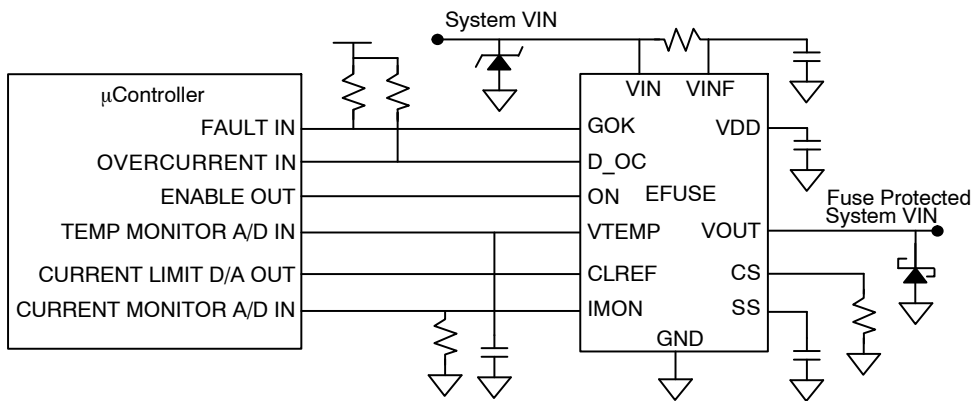

Figure 5. Application Schematic - Single EFuse with Controller

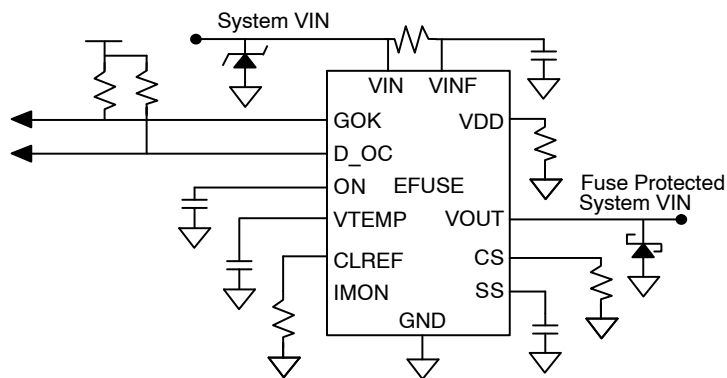

Figure 6. Application Schematic - Stand-alone Operation

NCP81295, NCP81296

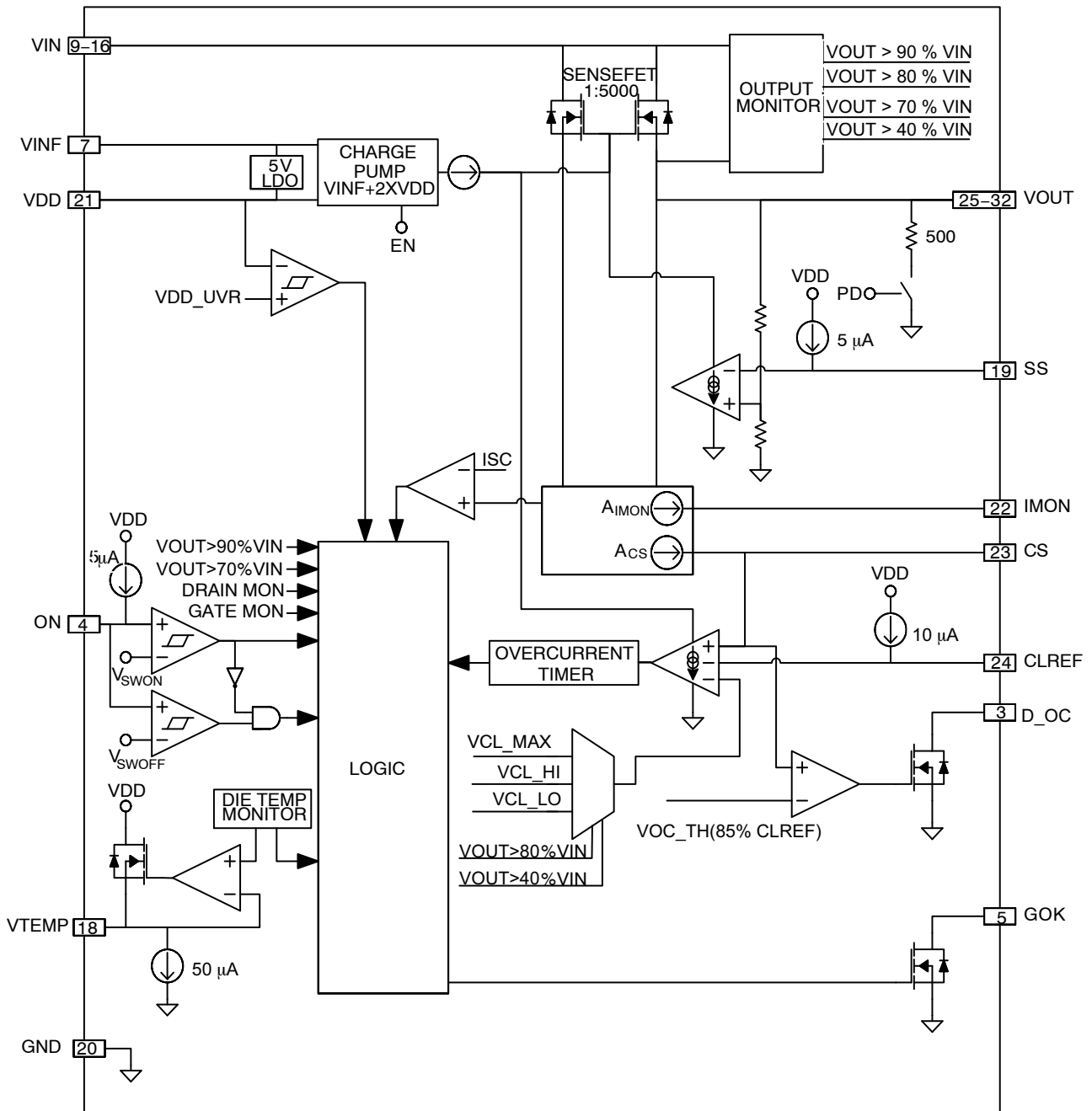

Figure 7. Block Diagram

NCP81295, NCP81296

Table 2. PIN DESCRIPTION

Pin No.	Symbol	Description
1	NC4	No electrical connection internally. May connect to any potential
2	NC5	No electrical connection internally. May connect to any potential
3	D_OC	Overcurrent indicator output (open drain). Low indicates the NCP81295 is limiting current. The D_OC output does not report current limiting during soft-start.
4	ON	Enable input and output pulldown resistance control.
5	GOK	OK status indicator output (open drain). Low indicates that the NCP81295 was turned off by a fault.
6	NC1	Test pin. Do not connect to this pin. Leave floating
7	VINF	Control circuit power supply input. Connect to VIN pins through an RC filter.
8	NC2	Internal FET sense pin. Do not connect to this pin. Leave floating
9	VIN09	Input of high current output switch
10	VIN10	Input of high current output switch
11	VIN11	Input of high current output switch
12	VIN12	Input of high current output switch
13	VIN13	Input of high current output switch
14	VIN14	Input of high current output switch
15	VIN15	Input of high current output switch
16	VIN16	Input of high current output switch
17	NC3	Internal FET gate pin. Do not connect to this pin. Leave floating
18	VTEMP	Analog temperature monitor output.
19	SS	Soft Start time programming pin. Connect a capacitor to this pin to set the softstart time.
20	GND	Ground
21	VDD	Linear regulator output
22	IMON	Analog current monitor output
23	CS	Current sense feedback output (current). Scaling the voltage developed at this pin with a resistor to ground makes this also an input for several current limiting functions and overcurrent indicator D_OC.
24	CLREF	Current limit setpoint input for normal operation (after soft-start).
25	VOUT25	Output of high current output switch
26	VOUT26	Output of high current output switch
27	VOUT27	Output of high current output switch
28	VOUT28	Output of high current output switch
29	VOUT29	Output of high current output switch
30	VOUT30	Output of high current output switch
31	VOUT31	Output of high current output switch
32	VOUT32	Output of high current output switch
33	VIN33	Input of high current output switch

NCP81295, NCP81296

Table 3. MAXIMUM RATINGS

Rating	Symbol	Min	Max	Unit
Pin Voltage Range (Note 2)	VINx, VINf	-0.3	20	V
Pin Voltage Range (Note 2)	VOUTx	-0.3 -1(<500 ms)	20	V
Pin Voltage Range (Note 2)	VDD	-0.3	6.0	V
Pin Voltage Range (Note 2)	All Other Pins	-0.3	VDD + 0.3	V
Operating Junction Temperature	T _{J(max)}		150	°C
Storage Temperature Range	TSTG	-55	150	°C
Lead Temperature Soldering Reflow (SMD Styles Only), Pb-Free Versions (Note 3)	T _{SLD}		260	°C

Stresses exceeding those listed in the Maximum Ratings table may damage the device. If any of these limits are exceeded, device functionality should not be assumed, damage may occur and reliability may be affected.

1. All signals referenced to GND unless noted otherwise.
2. Pin ratings referenced to VDD apply with VDD at any voltage within the VDD Pin Voltage Range.
3. For information, please refer to our Soldering and Mounting Techniques Reference Manual, SOLDERRM/D

Table 4. THERMAL CHARACTERISTICS

Rating	Symbol	Value	Unit
Thermal Resistance, Junction-to-Ambient (Note 4)	R _{θJA}	30	°C/W
Thermal Resistance, Junction-to-Top-Case	R _{θJCT}	50	°C/W
Thermal Resistance, Junction-to-Bottom-Case	R _{θJCB}	1.5	°C/W
Thermal Resistance, Junction-to-Board (Note 5)	R _{θJB}	1.5	°C/W
Thermal Resistance, Junction-to-Case (Note 6)	R _{θJC}	1.5	°C/W

4. Obtained by simulating the device mounted on a 500 mm², 1-oz Cu pad on a 80 mm x 80 mm, 1.6 mm thick 8-layer FR4 board.
5. R_{θJB} value based on hottest board temperature within 1 mm of the package.
6. R_{θJC} ≈ R_{θJCT} // R_{θJCB} (Two-Resistor Compact Thermal Model, JEESD15-3).

Table 5. RECOMMENDED OPERATING RANGES

Parameter	Symbol	Min	Max	Unit
VIN, VINf Pin Voltage Range		4.5	18	V
Maximum Continuous Output Current	I _{AVE}		50	A
Peak Output Current	I _{PEAK}		60	A
VDD Output Load Capacitance Range	C _{VDD}	2.2	10	μF
VTEMP Output Load Capacitance Range	C _{VTEMP}	0.1		μF
Softstart Duration	T _{SS}	10	100	ms
CS Load Resistance Range	R _{CS}	1.8	4	kΩ
CLREF Voltage Range	V _{CLREF}	0.2	1.4	V
Operating Junction Temperature	T _{J(OP)}	-40	125	°C

Functional operation above the stresses listed in the Recommended Operating Ranges is not implied. Extended exposure to stresses beyond the Recommended Operating Ranges limits may affect device reliability.

NCP81295, NCP81296

Table 6. ELECTRICAL CHARACTERISTICS ($V_{INx} = V_{INF} = 12.0\text{ V}$, $V_{ON} = 3.3\text{ V}$, $C_{VINx} = 0.1\ \mu\text{F}$, $C_{VDD} = 4.7\ \mu\text{F}$, $C_{VTEMP} = 0.1\ \mu\text{F}$, $R_{VTEMP} = 1\ \text{k}\Omega$, $C_{SS} = 100\ \text{nF}$ (unless specified otherwise) Min/Max values are valid for the temperature range $-40^{\circ}\text{C} \leq T_A = T_J \leq 125^{\circ}\text{C}$ unless noted otherwise, and are guaranteed by design and characterization through statistical correlation.

Parameter	Symbol	Test Conditions	Min	Typ	Max	Units
-----------	--------	-----------------	-----	-----	-----	-------

VINF INPUT

Quiescent Current		$V_{ON} > 1.4\text{ V}$, no load		3.23	5.0	mA
		$V_{ON} > 1.4\text{ V}$, fault			5.0	mA
		$V_{ON} < 0.8\text{ V}$		2.38	4.0	mA
		$V_{ON} < 0.8\text{ V}$, $V_{INF} = 16\text{ V}$			4.0	mA

VDD REGULATOR

VDD Output Voltage	V_{DD_NL}	$I_{VDD} = 0\text{ mA}$, $V_{INF} = 6\text{ V}$	4.7	5.09	5.3	V
VDD Load Capability	I_{DDLOAD}	$V_{INF} = 5.5\text{ V}$			30	mA
VDD Current Limit	I_{DD_CL}	$V_{INF} = 12\text{ V}$ and $V_{INF} = 6\text{ V}$	50	70		mA
VDD Dropout Voltage		$I_{VDD} = 25\text{ mA}$, $V_{INF} = 4.5\text{ V}$		85	200	mV
UVLO threshold – rising	V_{DD_UVR}		4.1	4.3	4.5	V
UVLO threshold – falling	V_{DD_UVF}		3.8	4.0	4.2	V

ON INPUT

Bias Current	I_{ON}	From pin into a 0 V or 1.5 V source	4.0	5.0	6.0	μA
Switch ON Threshold	V_{SWON}		1.3	1.4	1.5	V
Switch OFF/ Pulldown Upper Threshold	V_{SWOFF}			1.2		V
Pulldown Lower Threshold	V_{PDOFF}			0.8		V
Switch ON Delay Timer	t_{ON}	From ON transitioning above V_{SWON} to SS start	0.6	1.0	2.5	ms
Switch OFF Delay Time (Note 7)	t_{OFF}	From ON transitioning below V_{SWOFF} to GATE pulldown		1.7		μs
ON Current Source Clamp Voltage	V_{ON_CLMP}	Max pullup voltage of current source		3.0		V
Load Pulldown Delay Timer	t_{PD_DEL}	From ON transitioning into the range between V_{SWOFF} and V_{PDOFF}		2.0		ms
Output Pulldown Resistance	R_{PD}	$V_{OUT} = 12\text{ V}$, PD mode = 1		0.77		$\text{k}\Omega$

SS PIN

Bias Current	I_{SS}	From pin into a 0 V or 1 V source	4.62	5.15	5.62	μA
Gain to VOUT	A_{VSS}		9.6	10	10.4	V/V
SS Pulldown Voltage	V_{OL_SS}	0.1 mA into pin during ON delay		22		mV

GOK OUTPUT

Output Low Voltage	V_{OL_GOK}	$I_{GOK} = 1\text{ mA}$			0.1	V
Off-state Leakage Current	I_{LK_GOK}	$V_{GOK} = 5\text{ V}$			1.0	μA

Product parametric performance is indicated in the Electrical Characteristics for the listed test conditions, unless otherwise noted. Product performance may not be indicated by the Electrical Characteristics if operated under different conditions.

7. Guaranteed by design or characterization data. Not tested in production.

NCP81295, NCP81296

Table 6. ELECTRICAL CHARACTERISTICS ($V_{INx} = V_{INF} = 12.0\text{ V}$, $V_{ON} = 3.3\text{ V}$, $C_{VINf} = 0.1\ \mu\text{F}$, $C_{VDD} = 4.7\ \mu\text{F}$, $C_{VTEMP} = 0.1\ \mu\text{F}$, $R_{VTEMP} = 1\ \text{k}\Omega$, $C_{SS} = 100\ \text{nF}$ (unless specified otherwise) Min/Max values are valid for the temperature range $-40^\circ\text{C} \leq T_A = T_J \leq 125^\circ\text{C}$ unless noted otherwise, and are guaranteed by design and characterization through statistical correlation.

Parameter	Symbol	Test Conditions	Min	Typ	Max	Units
IMON/CS OUTPUT						
IMON or CS Current (single EFuse) Based on $10\ \mu\text{A}/\text{A} + 5\ \mu\text{A}$	I_{IMON}/I_{CS}	$T_J = 0\text{ to }85^\circ\text{C}$	IOUT = 5 A (Note 7)		55	μA
			IOUT = 10 A (Note 7)		105	μA
			IOUT = 25 A (Note 7)		255	μA
			IOUT = 50 A (Note 7)		505	μA
Accuracy (single EFuse)		$T_J = 0\text{ to }85^\circ\text{C}$	IOUT = 5 A (Note 7)	-6	+6	%
			IOUT = 10 A (Note 7)	-4	+4	%
			IOUT = 25 A (Note 7)	-4	+4	%
			IOUT = 50 A (Note 7)	-4	+4	%
IMON or CS Current Source Clamp Voltage	V_{IM_CLMP}/V_{CS_CLMP}	Max pullup voltage of current source		3.0		V
Pre-Biased Offset Current Load for Auto-Zero Op-Amp	I_{AZ_BIAS}			5.0		μA

CURRENT LIMIT & CLREF PIN

Current Limit Voltage	V_{CL_TH}	If $V_{CS} > V_{CL_TH}$ current limiting regulation occurs via gate	95	98	101	$\%V_{CLREF}$
Current Limit Clamp Voltage	V_{CL_LO}	$V_{OUT} < 40\%$, $V_{IN} V_{CLREF} > 0.15\text{ V}$	135	152	165	mV
	V_{CL_HI}	$40\% V_{IN} < V_{OUT} < 80\% V_{IN}$ $V_{CLREF} > 0.5\text{ V}$	480	504	520	mV
Max Current Limit Reference Voltage	V_{CL_MX}	$V_{OUT} > 80\% V_{IN}$, $V_{CLREF} > 1.6\text{ V}$	1.55	1.6	1.65	V
Response Time (Note 7)	t_{CL_REG}	$V_{CS} > V_{CLREF}$ until current limiting		200		μs
CLREF Bias Current	I_{CL}	From pin into a 1.2 V source	9.6	10	10.4	μA
CLREF Current Source Clamp Voltage	V_{CL_CLMP}	Max pullup voltage of current source		3.0		V
FET Turn-off Timer	t_{CL_LA}	Delay between current limit detection and FET turn-off (GOK = 0)		250		μs

D_OC OUTPUT

Overcurrent Threshold	V_{OC_TH}	If $V_{CS} > V_{OC_TH}$ D_OC pin pulls low	83	86	90	$\%V_{CLREF}$
Output Low Voltage	V_{OL_DOC}	$I_{DOC} = 1\ \text{mA}$			0.1	V
Off-state Leakage Current	I_{LK_DOC}	$V_{DOC} = 5\text{ V}$	-		1.0	μA
Delay (rising) (Note 7)		$V_{CS} < \text{limit}$ until D_OC rising	-	1.0		μs
Delay (falling) (Note 7)		$V_{CS} > \text{limit}$ until D_OC falling	-	1.0		μs

Product parametric performance is indicated in the Electrical Characteristics for the listed test conditions, unless otherwise noted. Product performance may not be indicated by the Electrical Characteristics if operated under different conditions.

7. Guaranteed by design or characterization data. Not tested in production.

NCP81295, NCP81296

Table 6. ELECTRICAL CHARACTERISTICS ($V_{INx} = V_{INF} = 12.0\text{ V}$, $V_{ON} = 3.3\text{ V}$, $C_{VINf} = 0.1\ \mu\text{F}$, $C_{VDD} = 4.7\ \mu\text{F}$, $C_{VTEMP} = 0.1\ \mu\text{F}$, $R_{VTEMP} = 1\ \text{k}\Omega$, $C_{SS} = 100\ \text{nF}$ (unless specified otherwise) Min/Max values are valid for the temperature range $-40^\circ\text{C} \leq T_A = T_J \leq 125^\circ\text{C}$ unless noted otherwise, and are guaranteed by design and characterization through statistical correlation.

Parameter	Symbol	Test Conditions	Min	Typ	Max	Units
SHORT CIRCUIT PROTECTION						
Current Threshold (Note 7)	I_{SC}	NCP81295		100		A
		NCP81296		80		A
Response Time (Note 7)	t_{SC}	From $I_{OUT} > I_{LIMSC}$ until gate pulldown		500		ns
VTEMP OUTPUT						
Bias Voltage	$V_{VTEMP25}$	At 25°C		450		mV
Gain (Note 7)	A_{VTEMP}	$0^\circ\text{C} \leq T_J \leq 125^\circ\text{C}$		10		mV/ $^\circ\text{C}$
Load Capability	R_{VTEMP}	At 25°C		1		k Ω
Pulldown Current	I_{VTEMP}	At 25°C		50		μA
THERMAL SHUTDOWN						
Temperature Shutdown (Note 7)	T_{TSD}	GOK pulls dow		140		$^\circ\text{C}$
OUTPUT SWITCH (FET)						
On Resistance	R_{DSon}	$T_J = 25^\circ\text{C}$		0.65	1.0	m Ω
Off-state leakage current	I_{DSoff}	$V_{IN} = 16\text{ V}$, $V_{ON} < 1.2\text{ V}$, $T_J = 25^\circ\text{C}$			1.0	μA
FAULT detection						
V_{DS} Short Threshold	V_{DS_TH}	Startup postponed if $V_{OUT} > V_{DS_TH}$ at $V_{ON} > V_{SWON}$ transition		88.8		%VIN
V_{DS} Short OK Threshold	V_{DS_OK}	Startup resumed if $V_{OUT} < V_{DS_OK}$ anytime after postponed		68.6		%VIN
V_{GD} Short Threshold	V_{DG_TH}	Startup postponed if $V_G > V_{DG_TH}$ at $V_{ON} > V_{SWON}$ transition		3.1		V
V_{GD} Short OK Threshold	V_{DG_OK}	Startup resumed if $V_G < V_{DG_OK}$ anytime after postponed		3.0		V
V_G Low Threshold	V_{G_TH}	Latch/Restart if $V_{GD} < V_{G_TH}$ after t_{SSF_END} or t_{GATE_FLT}		5.4		V
V_{OUT} Low Threshold	V_{OUTL_TH}	Latch/Restart if $V_{OUT} < V_{OUTL_TH}$ after t_{SSF_END}		90		%VIN
Gate Fault Timer (Note 7)	t_{GATE_FLT}	Time from $V_{GD} < V_{G_TH}$ transition after t_{SSF_END} completed		200		ms
Startup Timer Failsafe (Note 7)	t_{SSF_END}	Time from $V_{ON} > V_{SWON}$ transition, Max programmable softstart time		200		ms
AUTO-RETRY (NCP81296)						
Auto-Retry Delay	t_{DLY_RETRY}	Delay from power-down to retry of startup		1000		ms

Product parametric performance is indicated in the Electrical Characteristics for the listed test conditions, unless otherwise noted. Product performance may not be indicated by the Electrical Characteristics if operated under different conditions.

7. Guaranteed by design or characterization data. Not tested in production.

NCP81295, NCP81296

TYPICAL CHARACTERISTICS

Test Conditions: $V_{in} = 12\text{ V}$, $R_{cs} = 2\text{ k}\Omega$, $C_{ss} = 200\text{ nF}$, $R_{CLREF} = 121\text{ k}\Omega$, $R_{IMON} = 2\text{ k}\Omega$

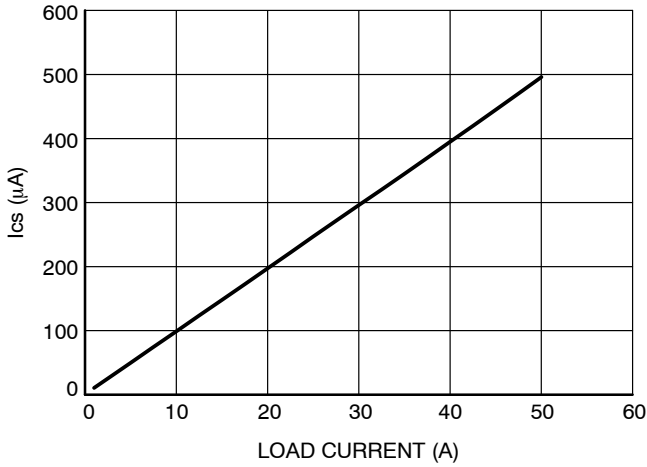

Figure 8. Ics vs. Load Current

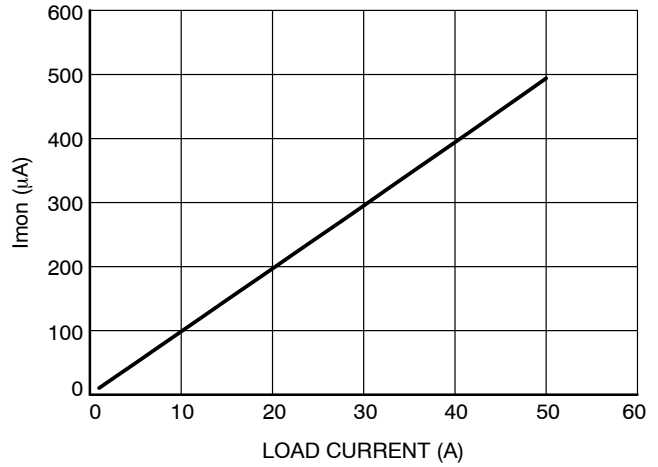

Figure 9. Imon vs. Load Current

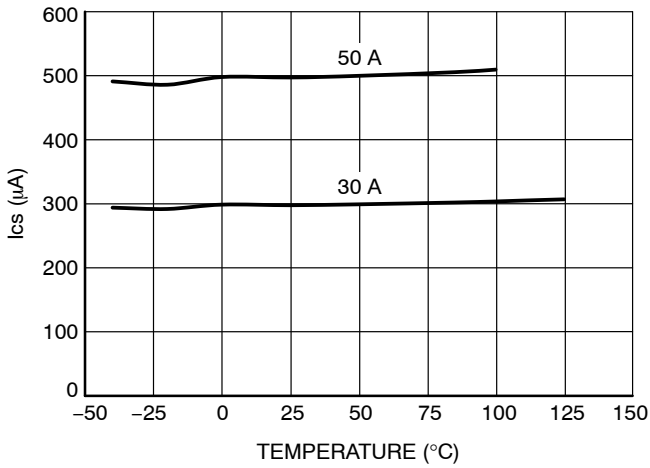

Figure 10. Ics vs. Temperature

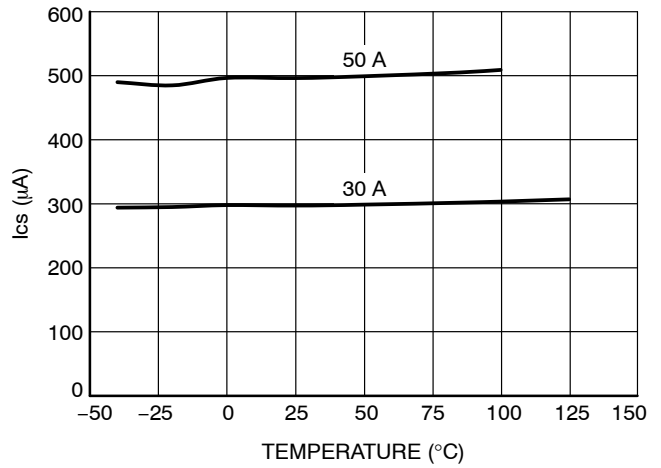

Figure 11. Imon vs. Temperature

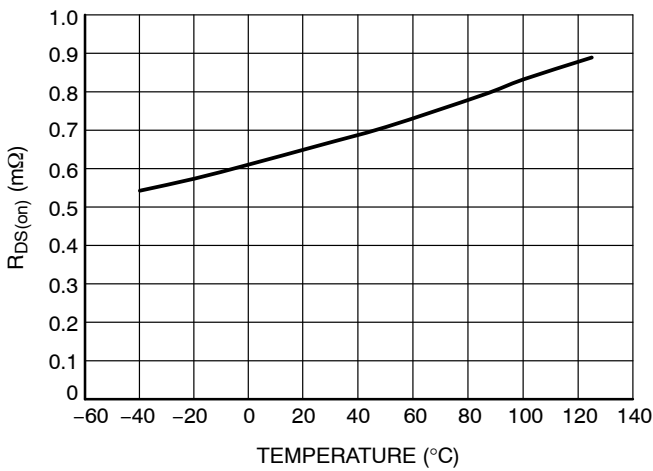

Figure 12. Output Switch $R_{DS(on)}$ @ 22 A vs. Temperature

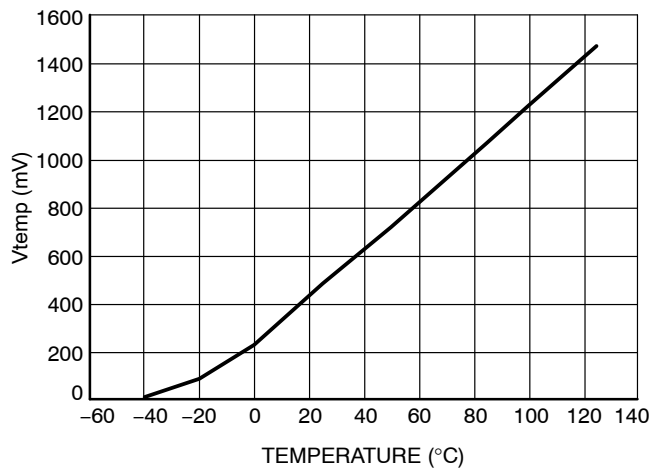

Figure 13. Vtemp vs. Temperature (no load)

NCP81295, NCP81296

TYPICAL CHARACTERISTICS

Test Conditions: $V_{in} = 12\text{ V}$, $R_{cs} = 2\text{ k}\Omega$, $C_{ss} = 200\text{ nF}$, $R_{CLREF} = 121\text{ k}\Omega$, $R_{IMON} = 2\text{ k}\Omega$

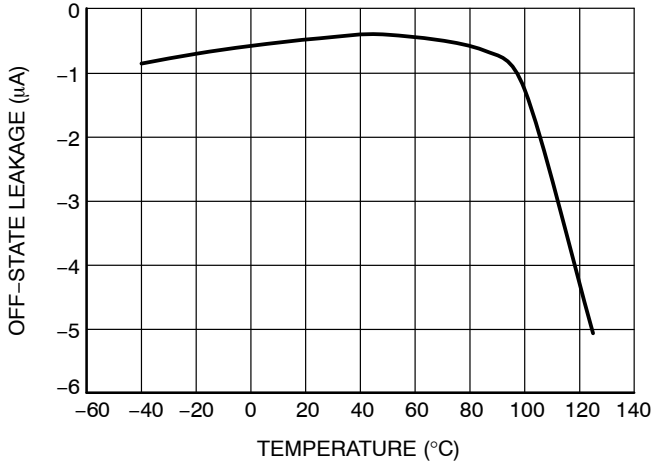

Figure 14. Output Switch Off-state Leakage vs. Temperature

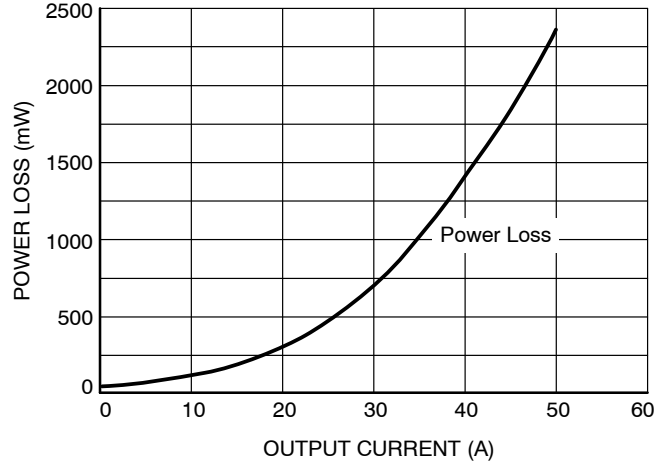

Figure 15. Power Loss vs. Load Current

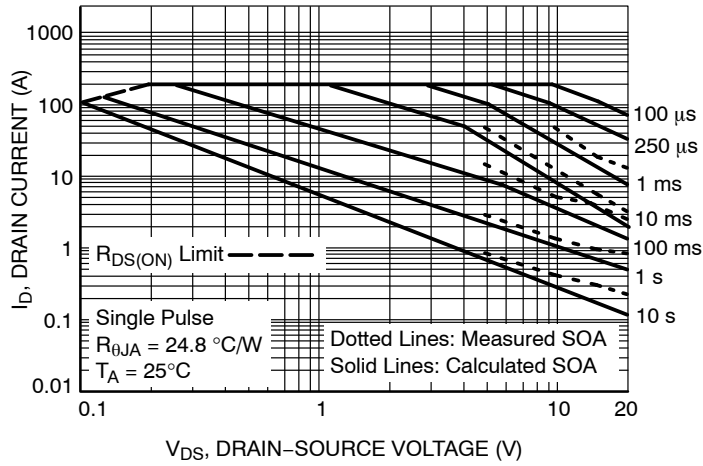

Figure 16. Internal FET's Safe Operating Area (SOA)

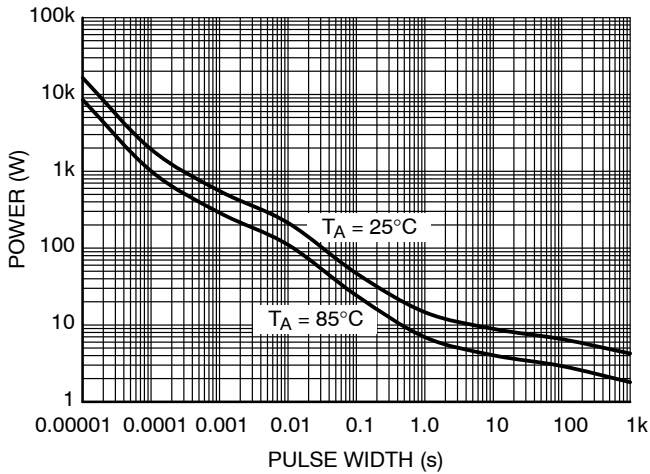

Figure 17. Single Pulse Power Rating (10 μs - 1000 s, Junction-to-Ambient, Note 4)

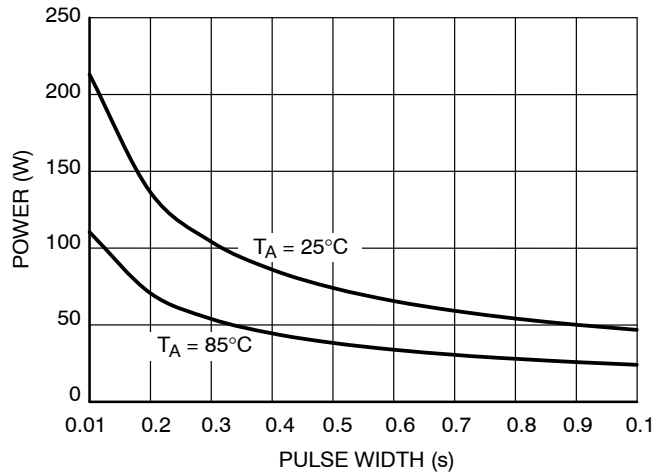

Figure 18. Single Pulse Power Rating (10 ms - 100 ms, Junction-to-Ambient, Note 4)

NCP81295, NCP81296

TYPICAL CHARACTERISTICS

Test Conditions: $V_{in} = 12\text{ V}$, $R_{cs} = 2\text{ k}\Omega$, $C_{ss} = 200\text{ nF}$, $R_{CLREF} = 121\text{ k}\Omega$, $R_{IMON} = 2\text{ k}\Omega$

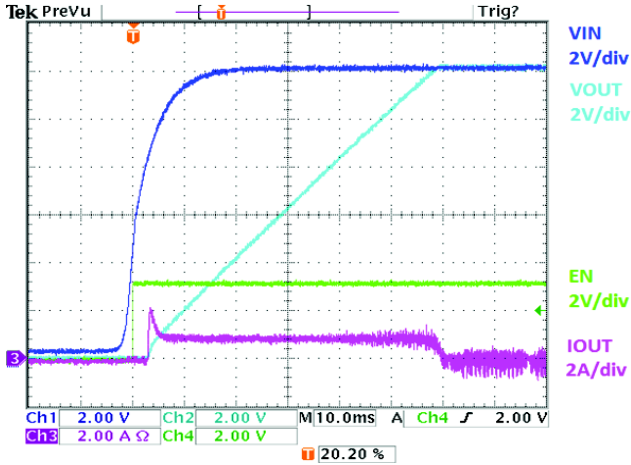

Figure 19. Start Up by VIN (Iout = 0 A)

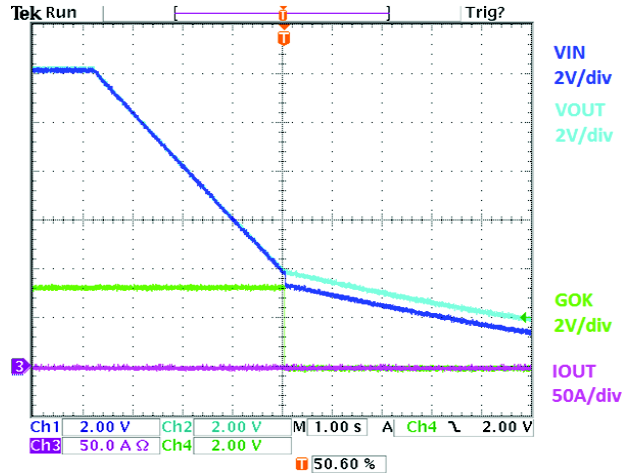

Figure 20. Shut Down by VIN (Iout = 0 A)

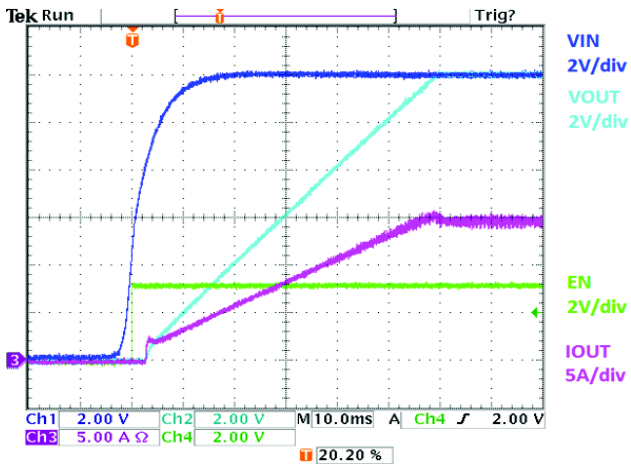

Figure 21. Start Up by VIN (Iout = 15 A)

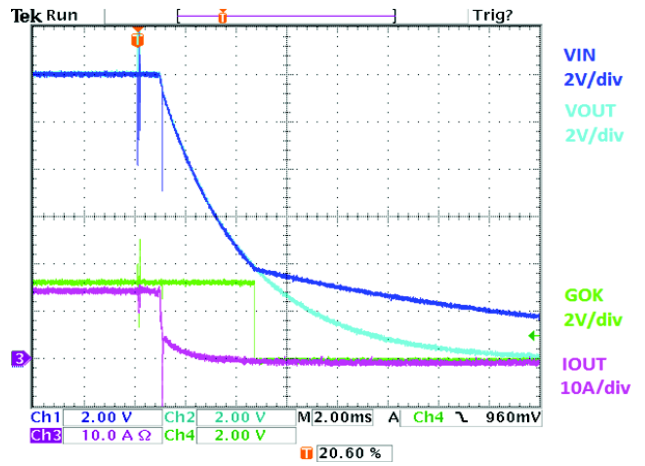

Figure 22. Shut Down by VIN (Iout = 15 A)

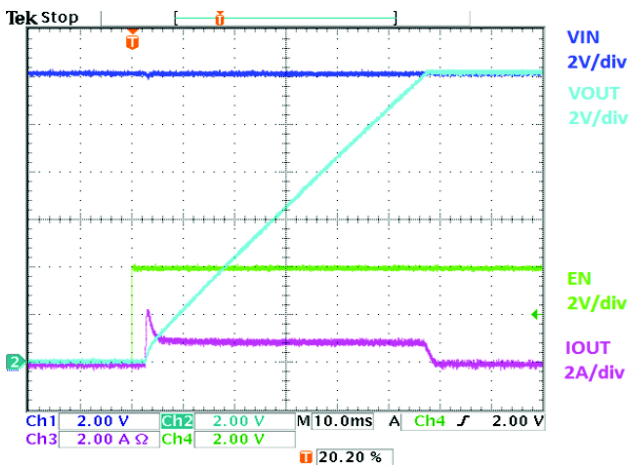

Figure 23. Start Up by EN (Iout = 0 A)

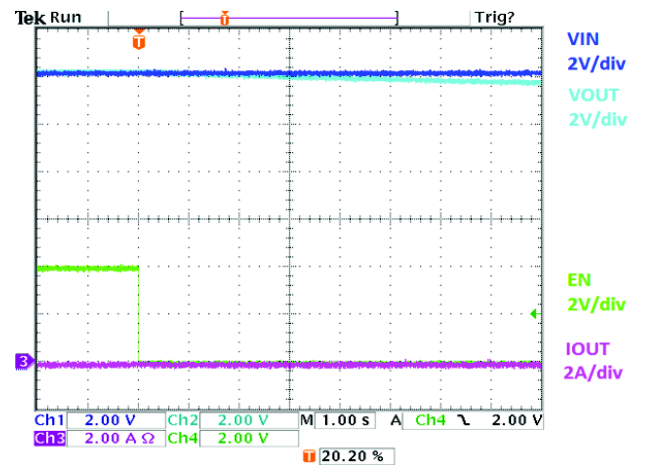

Figure 24. Shut Down by EN (Iout = 0 A)

NCP81295, NCP81296

TYPICAL CHARACTERISTICS

Test Conditions: $V_{in} = 12\text{ V}$, $R_{cs} = 2\text{ k}\Omega$, $C_{ss} = 200\text{ nF}$, $R_{CLREF} = 121\text{ k}\Omega$, $R_{IMON} = 2\text{ k}\Omega$

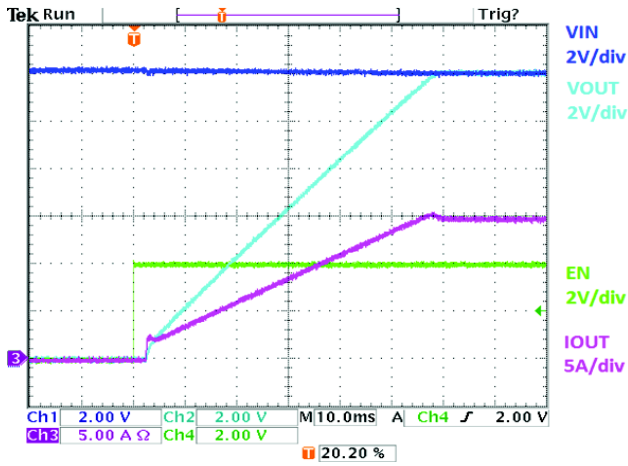

Figure 25. Start Up by EN (Iout = 15 A)

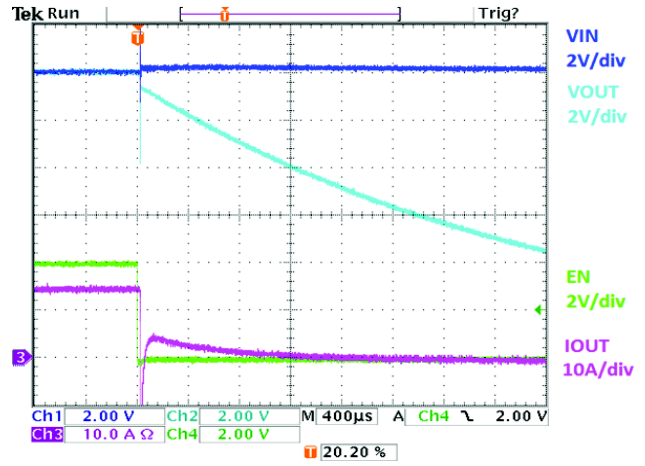

Figure 26. Shut Down by EN (Iout = 15 A)

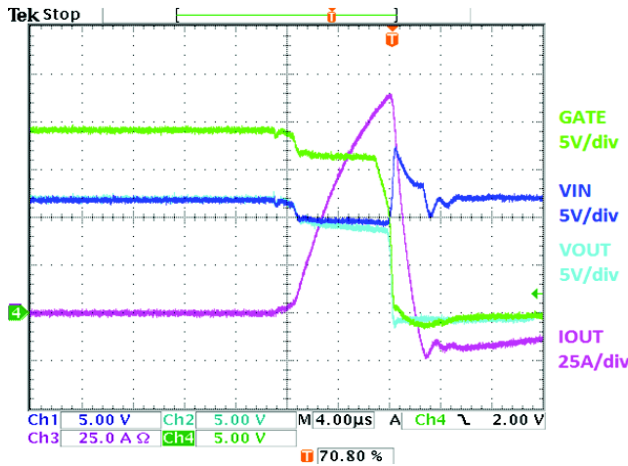

Figure 27. Short Circuit during Normal Operation (Iout = 0 A)

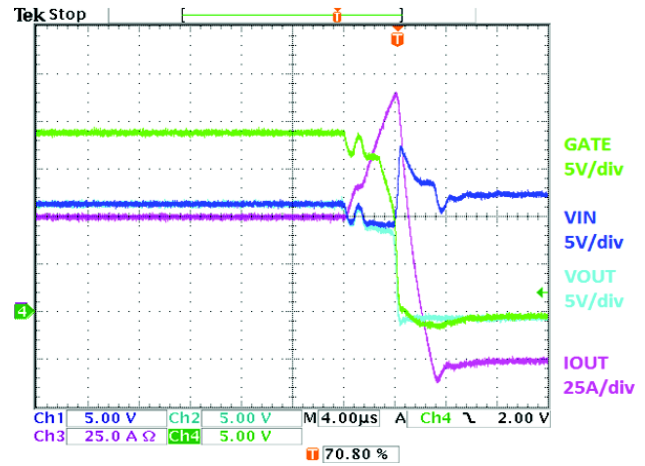

Figure 28. Short Circuit during Normal Operation (Iout = 50 A)

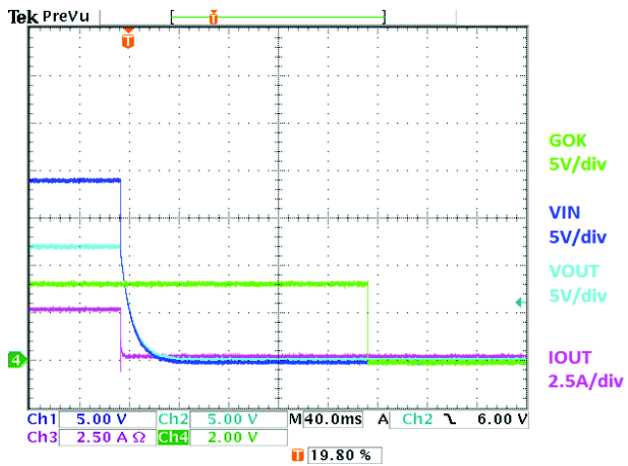

Figure 29. Short FET's Gate During Normal Operation (Iout = 2.5 A)

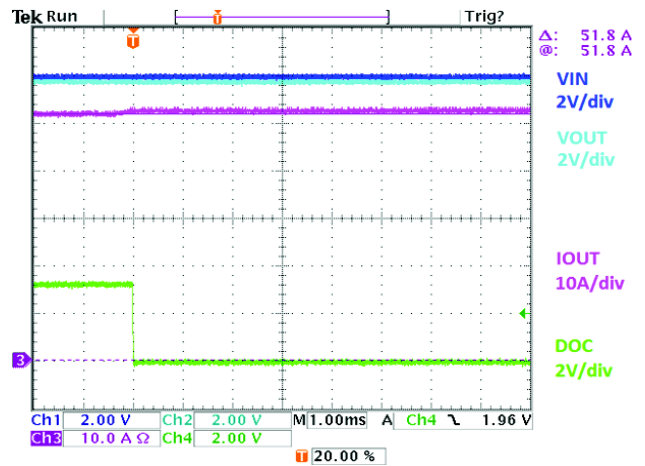

Figure 30. DOC Index for Current Limit during Normal Operation (Iout = 51.8 A)

NCP81295, NCP81296

TYPICAL CHARACTERISTICS

Test Conditions: $V_{in} = 12\text{ V}$, $R_{cs} = 2\text{ k}\Omega$, $C_{ss} = 200\text{ nF}$, $R_{CLREF} = 121\text{ k}\Omega$, $R_{IMON} = 2\text{ k}\Omega$

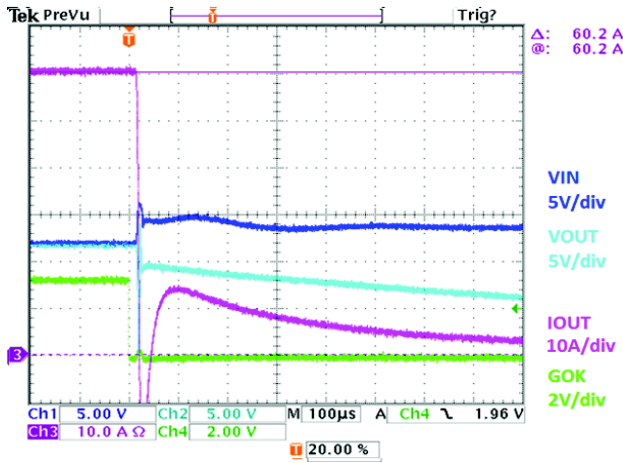

Figure 31. OCP during Normal Operation($I_{out}=60.2\text{A}$)

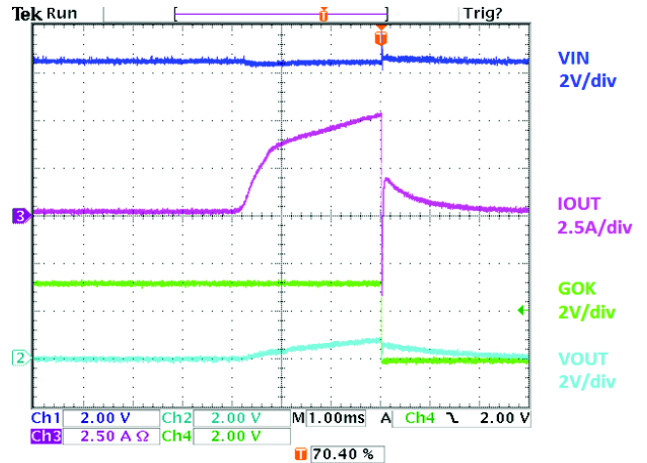

Figure 32. OCP during Power Up by Enable

General Information

The NCP81295/6 is an N-channel MOSFET co-packaged with a smart hotswap controller. It is suited for high-side current limiting and fusing in hot-swap applications. It can be used either alone, or in a parallel configuration for higher current applications.

VDD Output (Auxiliary Regulated Supply)

An internal linear regulator draws current from the VIN pin to produce and regulate voltage at the VDD pin. This auxiliary output supply is current-limited to I_{DD_CL}. A ceramic capacitor in the range of 2.2 μF to 10 μF must be placed between the VDD and GND pins, as close to the NCP81295/6 as possible.

ON Input (Device Enable)

When the ON pin voltage (V_{ON}) is higher than V_{SWON}, and no undervoltage (UVLO) or output switch faults are present, the output switch turns on. When V_{ON} is lower than V_{SWOFF}, the output switch is off. If V_{ON} is between V_{PDOFF} and V_{SWOFF} for longer than t_{PD_DEL}, the output switches off, and a pulldown resistance to ground, of R_{PD}, is applied to VOUT.

For standalone applications, the ON pin sources current I_{ON}, which can be used to delay output switch turn-on for some time after the appearance of input voltage by connecting a capacitor from the ON pin to ground.

A bi-level control signal driving to ground can be biased up with a resistive divider to produce ON input levels between V_{PDOFF} < V_{ON} < V_{SWON} and V_{ON} > V_{SWON} in order to always apply the output pulldown when the output switch is off.

SS Output (Soft-Start)

When the output switch first turns on, it does so in a controlled manner. The output voltage (VOUT) follows the voltage at the SS pin, produced by current I_{SS} into a capacitor from SS to ground. The duration of soft-start can be programmed by selection of the capacitor value. In parallel fuse applications, the SS pins of all fuses should be shorted together to one shared SS capacitor. Internal soft-start load balancing circuitry will ensure the soft-start current is shared between paralleled devices, so as not to stress one device more than another or hit a soft start-current limit.

The soft-start capacitor value can be calculated by:

$C_{SS} = (t_{SS} * I_{SS} * AV_{SS})/V_{IN}$ (where t_{SS} is the target soft-start time). The recommended range of t_{SS} is 10 – 100 ms (see Table 5).

The typical C_{SS} values for different t_{SS} are listed below:

t _{SS} (ms)	C _{SS} (nF)	t _{SS} (ms)	C _{SS} (nF)
10	47	60	270
20	82	70	330
30	120	80	330
40	180	90	470
50	220	100	470

The maximum load capacitor value NCP81295/6 can power up depends on the device soft-start time. When V_{IN} = 12 V, R_{CS} = 2 kΩ, R_{LOAD} = 2.4 Ω, their relationship for different paralleled operations are shown as below chart (above line device shuts down safely due to protection, below line device powers up successfully without trigger protection):

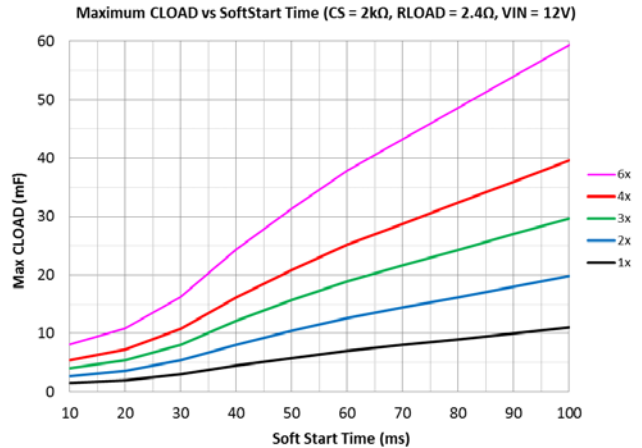

GOK Output (Gate OK)

The GOK pin is an open-drain output that is pulled low to report the fault under the following conditions:

- V_{DD} voltage is below UVLO voltage at any time.
- V_{ON} disabled and V_{DS_OK} is false (indicates a short from VIN to VOUT).
- V_{ON} disabled and V_{DG_OK} is false (indicates a short from GATE to VIN).
- V_{ON} enabled and V_{SS_OK} is false at t_{SSF_END} (indicates VOUT < 90% after soft-start completes – FET latches off for NCP81295/auto-retries for NCP81296).
- V_{ON} enabled and V_G is below V_{G_TH} at t_{SSF_END} (indicates leakage on GATE in startup – FET latches off for NCP81295/auto-retries for NCP81296).
- V_{ON} enabled and V_G is below V_{G_TH} after t_{GATE_FLT} (indicates leakage on GATE during normal operation – FET latches off for NCP81295/auto-retries for NCP81296).
- V_{ON} enabled and a current-limiting condition lasts longer than t_{OC_LA} (FET latches off for NCP81295/auto-retries for NCP81296).
- V_{ON} enabled and device temperature is above T_{TSD} (indicates an over-temperature is detected – FET latches off for NCP81295/auto-retries for NCP81296).

Usually GOK can't be used as power good to indicate the output voltage is in the normal range. Bringing VDD below the UVLO voltage is required to release a latching condition.

IMON Output (Current Monitor)

The IMON pin sources a current that is A_{IMON} times the VOUT output current. A resistor connected from the IMON pin to ground can be used to monitor current information as a voltage up to V_{IM_CLMP} . A capacitor of any value in parallel with the IMON resistor can be used to low-pass filter the IMON signal without affecting any internal operation of the device.

CLREF Pin (Current Limit and Over-Current Reference)

The CLREF pin voltage determines the current-limit regulation point and over-current indication point via its interaction with the CS pin voltage. The CLREF voltage can be applied by an external source, such as a hot-swap controller or D-to-A converter, or developed across a programming resistor to ground by the CLREF bias current, I_{CL} . The recommended range of CLREF voltage is 0.2 – 1.4 V (see Table 5).

CS Input/Output (Current Set)

The CS pin is both an input and an output. The CS pin sources a current that is A_{CS} times the VOUT current. This produces a voltage on the CS pin that is the product of the CS pin current and an external CS pin resistance to ground.

The voltage generated on V_{CS} determines the D_OC over-current indicator trip point and the current-limit regulation point, via its interaction with the voltage on CLREF pin.

When the voltage on the CS pin is higher than V_{OC_TH} , D_OC is pulled low. If the CS pin voltage drops below V_{OC_TH} , the D_OC pin is released and gets pulled high by the external pullup resistor. D_OC transitions based on the following formula: $I_{OUT} = V_{OC_TH} / (R_{CS} * A_{CS})$.

The V_{OC_TH} trip point is based on a percentage of V_{CLREF} (85%).

During normal operation ($V_{ON} > V_{SWON}$ for longer than t_{SS_END}), if the voltage on the CS pin is above V_{CL_TH} (V_{CL_TH} is clamped at V_{CL_MX} if $V_{CL_TH} > V_{CL_MX}$), then the gate voltage of the FET is modulated to limit current into the output based on the following formula:

$I_{OUT} = V_{CL_TH} / (R_{CS} * A_{CS})$. The V_{CL_TH} regulation point is equal to V_{CLREF} .

During startup ($V_{ON} > V_{SWON}$ for less than t_{SS_END}), the current limit reference voltage is clamped according to the following:

- When $V_{OUT} < 40\%$ of V_{IN} , $V_{CL_TH} = V_{CL_LO}$ or V_{CLREF} (whichever is lower).
- When V_{OUT} is between 40% and 80% of V_{IN} , $V_{CL_TH} = V_{CL_HI}$ or V_{CLREF} (whichever is lower).
- When V_{OUT} exceeds 80% of V_{IN} , $V_{CL_TH} = V_{CL_MX}$ or V_{CLREF} (whichever is lower).

If a current limiting condition exists anytime for a continuous duration $> t_{CL_LA}$, then the device latches off (NCP81295) or restarts (NCP81296).

The CS pin must have no capacitive loading other than parasitic device/board capacitance to function correctly. The recommended range of R_{CS} is 1.8 – 4 k Ω (see Table 5).

CS AMP OFFSET BIAS

NCP81295/6 use an auto-zero Op-Amp with low input offset to sense current in FET with high-accuracy, and an pre-biased offset current load, I_{AZ_BIAS} is need for this Op-Amp to always keep it to maintain this low input offset (<100 μ V). The internal IMON and CS current source follow below relationship:

$$I_{OUT} = \frac{I_{CS} - I_{AZ_BIAS}}{10 \mu} \quad (\text{eq. 1})$$

and

$$I_{OUT} = \frac{I_{MON} - I_{AZ_BIAS}}{10 \mu} \quad (\text{eq. 2})$$

For typical 5 μ A I_{AZ_BIAS} , there has 0.5 A positive off-set in I_{OUT} sense.

D_OC Output (Over-current Indicator)

The D_OC pin is an open-drain output that indicates when an over-current condition exists after soft-start is complete. When the voltage on the CS pin is higher than V_{OC_TH} , D_OC is pulled low. If output current drops below V_{OC_TH} , the D_OC pin is released and gets pulled high by an external pullup resistor.

VTEMP Output (Temperature Indicator)

VTEMP is a voltage output proportional to device temperature, with an offset voltage. The VTEMP output can source much more current than it can sink, so that if multiple VTEMP outputs are connected together, the voltage of all VTEMP outputs will be driven to the voltage produced by the hottest NCP81295/6. A 100 nF capacitor or greater must be connected from the VTEMP pin to ground.

Auto-Retry Restart (NCP81296)

Under certain fault conditions, the FET is turned off and another soft-start procedure takes place. Between the fault and the new soft-start, there is a delay of t_{DLY_RETRY} . The protection features that use this hiccup mode restart are:

- Over-Current
- Short-Circuit Detection
- Over-Temperature
- Excessive Soft-Start Duration
- Gate Leakage

Protection Features

For the following protection features, the FET either latches off (NCP81295) or the FET turns off and initiates a restart (NCP81296), unless noted otherwise.

NCP81295, NCP81296

Excessive Current Limiting

If a current limiting condition exists anytime for a continuous duration $> t_{CL_LA}$, then the FET latches/restarts.

Excessive Soft-Start Duration

If $V_{OUT} < V_{OUTL_TH}$ when t_{SSF_END} expires, then the FET latches/restarts.

Short Circuit Detection

If switch current exceeds I_{SC} , the device reacts within t_{SC} , and the FET latches/restarts. The short-circuit current monitor is independent of CS, CLREF, IMON and current limit setting (cannot be changed externally).

Over-Temperature Shutdown

If the FET controller temperature $> T_{TSD}$, then the FET latches/restarts.

FET Fault Detection

The device contains various FET monitoring circuits:

- VIN to VOUT short, non-latching/non-auto-retry condition. If the device is disabled and $V_{OUT} > V_{DS_TH}$ then GOK is pulled low and the device is prevented from powering up. The device is allowed to power up once $V_{OUT} < V_{DS_OK}$.
- GATE to VIN short, non-latching/non-auto-retry condition. If the device is disabled and

$GATE (Pin 8) > V_{DG_TH}$, then GOK is pulled low and device is prevented from powering up. The device allowed to power up once $GATE < V_{DG_OK}$.

- GATE leakage – startup.
If $(GATE - V_{INF}) < V_{G_TH}$ at t_{SSF_END} , then GOK is pulled low and FET latches/restarts.
- GATE leakage – normal operation.
If $(GATE - V_{INF}) < V_{G_TH}$ for t_{GATE_FLT} time after the soft-start timer completes, then GOK is pulled low and device latches/restarts.

FET SOA Limits

In-built timed current limits and fault-monitoring circuits ensure the copackaged FET is always kept within SOA limits.

Multiple Fuse Power Up

When multiple NPC81295 are paralleled together as shown in Figure 4, the NPC81295s will turn on together. Keeping the current through each switch within 1 A (typical) helps to prevent overstress on each switching during soft-start.

Due to NCP81296 is featured by Auto-Retry Mode protection, please follow the below reference schematic of NCP81296 for paralleled operation.

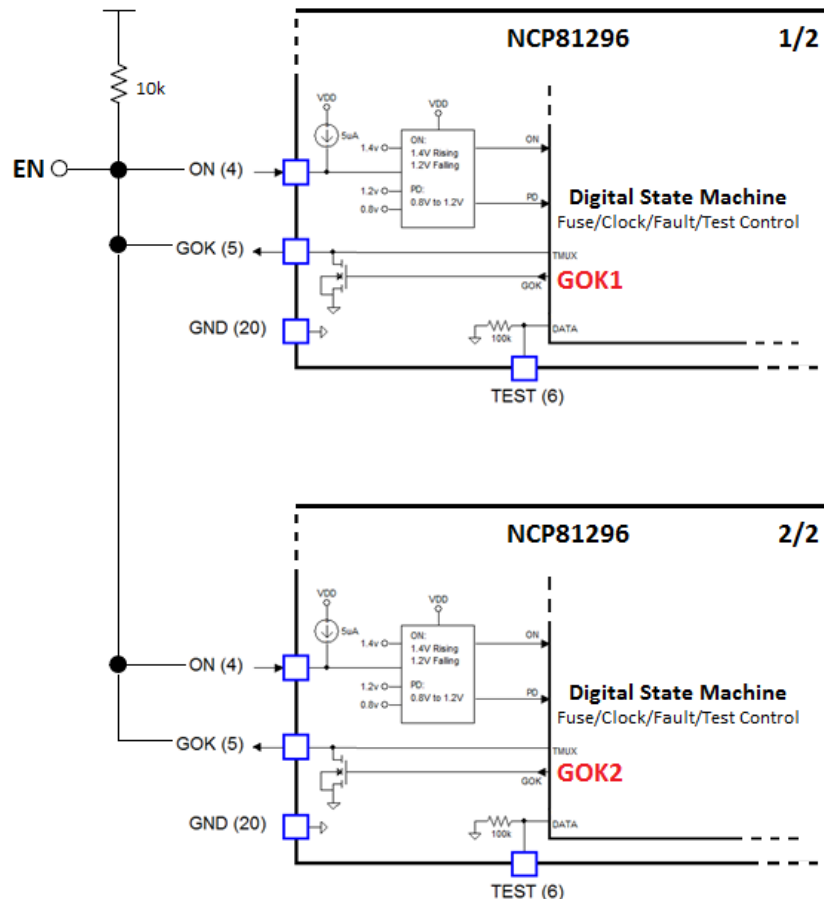

NCP81295, NCP81296

When paralleled multiple NCP81295 encounter fault, the system can recover the E-fuse by resetting their VDD with below buffer and reset circuit.

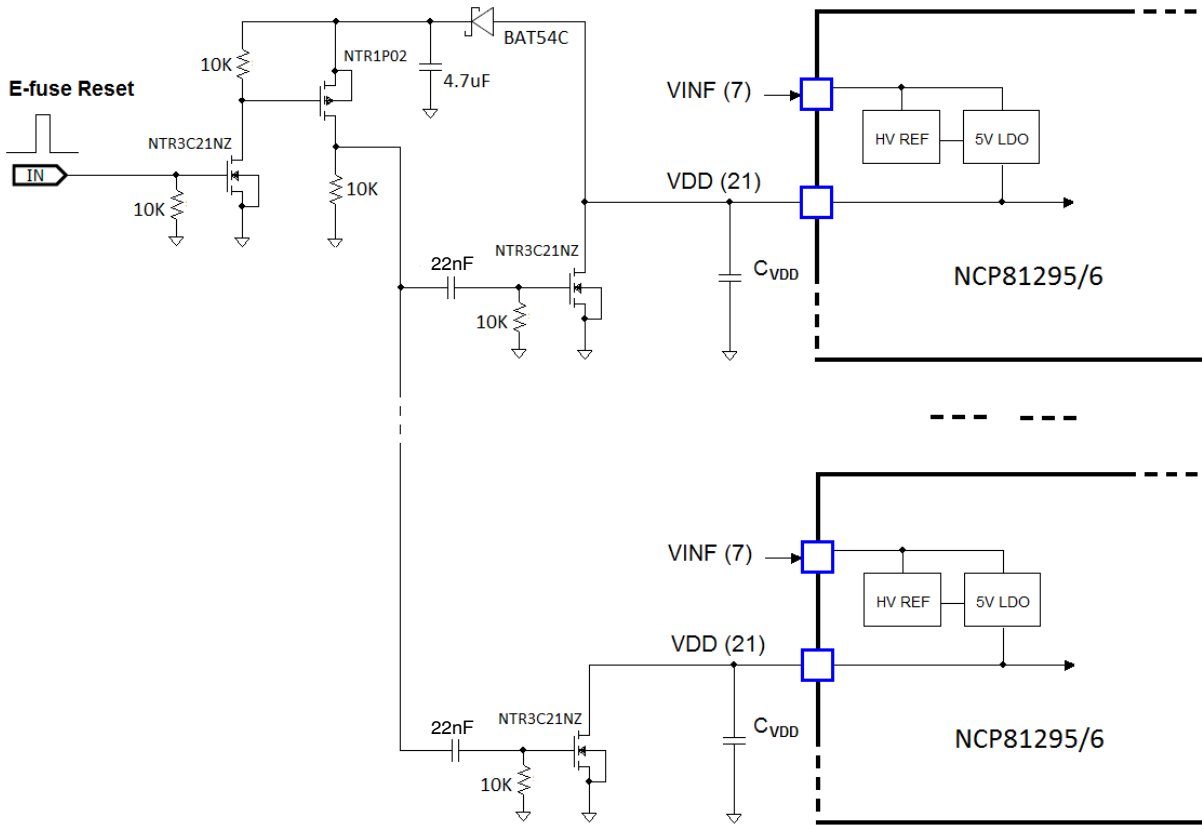

NCP81295, NCP81296

PACKAGE DIMENSIONS

LQFN32 5x5, 0.5P
CASE 487AA
ISSUE A

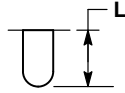
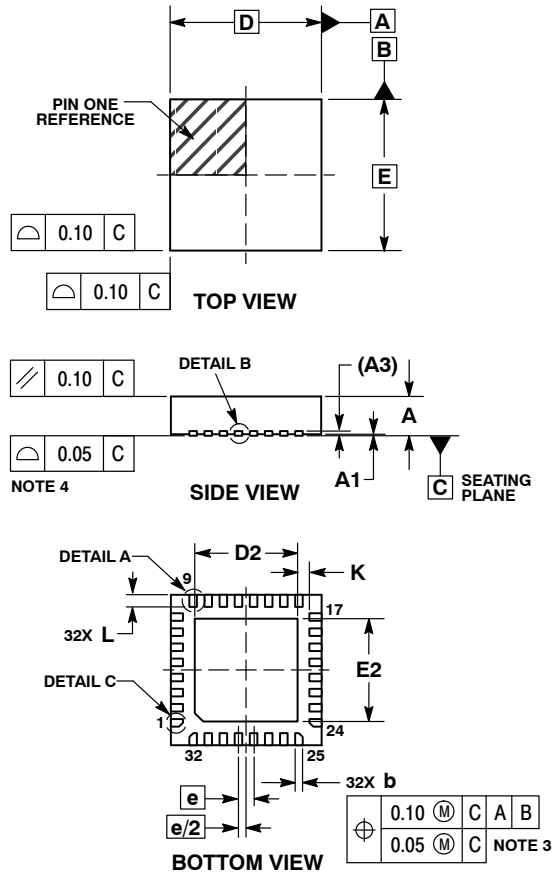

DETAIL A
ALTERNATE
CONSTRUCTION

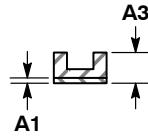

DETAIL B
ALTERNATE
CONSTRUCTION

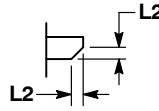

DETAIL C
4 PLACES

NOTES:

1. DIMENSIONING AND TOLERANCING PER ASME Y14.5M, 1994.
2. CONTROLLING DIMENSION: MILLIMETERS.
3. DIMENSION b APPLIES TO PLATED TERMINAL AND IS MEASURED BETWEEN 0.15 AND 0.30 MM FROM THE TERMINAL TIP.
4. COPLANARITY APPLIES TO THE EXPOSED PAD AS WELL AS THE TERMINALS.

MILLIMETERS		
DIM	MIN	MAX
A	1.20	1.40
A1	---	0.05
A3	0.20	REF
b	0.18	0.30
D	5.00	BSC
D2	3.30	3.50
E	5.00	BSC
E2	3.30	3.50
e	0.50	BSC
L	0.30	0.50
L2	0.13	REF

**RECOMMENDED
SOLDERING FOOTPRINT***

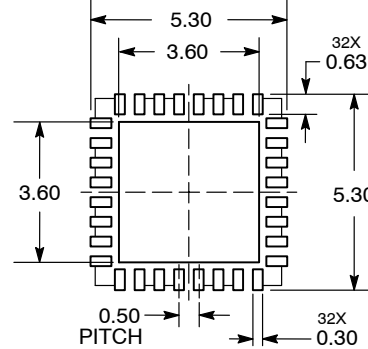

DIMENSIONS: MILLIMETERS

*For additional information on our Pb-Free strategy and soldering details, please download the ON Semiconductor Soldering and Mounting Techniques Reference Manual, SOLDERRM/D.

ON Semiconductor and are trademarks of Semiconductor Components Industries, LLC dba ON Semiconductor or its subsidiaries in the United States and/or other countries. ON Semiconductor owns the rights to a number of patents, trademarks, copyrights, trade secrets, and other intellectual property. A listing of ON Semiconductor's product/patent coverage may be accessed at www.onsemi.com/site/pdf/Patent-Marking.pdf. ON Semiconductor reserves the right to make changes without further notice to any products herein. ON Semiconductor makes no warranty, representation or guarantee regarding the suitability of its products for any particular purpose, nor does ON Semiconductor assume any liability arising out of the application or use of any product or circuit, and specifically disclaims any and all liability, including without limitation special, consequential or incidental damages. Buyer is responsible for its products and applications using ON Semiconductor products, including compliance with all laws, regulations and safety requirements or standards, regardless of any support or applications information provided by ON Semiconductor. "Typical" parameters which may be provided in ON Semiconductor data sheets and/or specifications can and do vary in different applications and actual performance may vary over time. All operating parameters, including "Typicals" must be validated for each customer application by customer's technical experts. ON Semiconductor does not convey any license under its patent rights nor the rights of others. ON Semiconductor products are not designed, intended, or authorized for use as a critical component in life support systems or any FDA Class 3 medical devices or medical devices with a same or similar classification in a foreign jurisdiction or any devices intended for implantation in the human body. Should Buyer purchase or use ON Semiconductor products for any such unintended or unauthorized application, Buyer shall indemnify and hold ON Semiconductor and its officers, employees, subsidiaries, affiliates, and distributors harmless against all claims, costs, damages, and expenses, and reasonable attorney fees arising out of, directly or indirectly, any claim of personal injury or death associated with such unintended or unauthorized use, even if such claim alleges that ON Semiconductor was negligent regarding the design or manufacture of the part. ON Semiconductor is an Equal Opportunity/Affirmative Action Employer. This literature is subject to all applicable copyright laws and is not for resale in any manner.

PUBLICATION ORDERING INFORMATION

LITERATURE FULFILLMENT:

Literature Distribution Center for ON Semiconductor
19521 E. 32nd Pkwy, Aurora, Colorado 80011 USA
Phone: 303-675-2175 or 800-344-3860 Toll Free USA/Canada
Fax: 303-675-2176 or 800-344-3867 Toll Free USA/Canada
Email: orderlit@onsemi.com

N. American Technical Support: 800-282-9855 Toll Free
USA/Canada
Europe, Middle East and Africa Technical Support:
Phone: 421 33 790 2910

ON Semiconductor Website: www.onsemi.com
Order Literature: <http://www.onsemi.com/orderlit>

For additional information, please contact your local Sales Representative



Компания «ЭлектроПласт» предлагает заключение долгосрочных отношений при поставках импортных электронных компонентов на взаимовыгодных условиях!

Наши преимущества:

- Оперативные поставки широкого спектра электронных компонентов отечественного и импортного производства напрямую от производителей и с крупнейших мировых складов;
- Поставка более 17-ти миллионов наименований электронных компонентов;
- Поставка сложных, дефицитных, либо снятых с производства позиций;
- Оперативные сроки поставки под заказ (от 5 рабочих дней);
- Экспресс доставка в любую точку России;
- Техническая поддержка проекта, помощь в подборе аналогов, поставка прототипов;
- Система менеджмента качества сертифицирована по Международному стандарту ISO 9001;
- Лицензия ФСБ на осуществление работ с использованием сведений, составляющих государственную тайну;
- Поставка специализированных компонентов (Xilinx, Altera, Analog Devices, Intersil, Interpoint, Microsemi, Aeroflex, Peregrine, Syfer, Eurofarad, Texas Instrument, Miteq, Cobham, E2V, MA-COM, Hittite, Mini-Circuits, General Dynamics и др.);

Помимо этого, одним из направлений компании «ЭлектроПласт» является направление «Источники питания». Мы предлагаем Вам помощь Конструкторского отдела:

- Подбор оптимального решения, техническое обоснование при выборе компонента;
- Подбор аналогов;
- Консультации по применению компонента;
- Поставка образцов и прототипов;
- Техническая поддержка проекта;
- Защита от снятия компонента с производства.



Как с нами связаться

Телефон: 8 (812) 309 58 32 (многоканальный)

Факс: 8 (812) 320-02-42

Электронная почта: org@eplast1.ru

Адрес: 198099, г. Санкт-Петербург, ул. Калинина, дом 2, корпус 4, литера А.