



+2.7 V to +5.5 V, Serial Input, Dual Voltage Output 8-Bit DAC

AD7303

FEATURES

- Two 8-Bit DACs in One Package
- 8-Pin DIP/SOIC and microSOIC Packages
- +2.7 V to +5.5 V Operation
- Internal & External Reference Capability
- Individual DAC Power-Down Function
- Three-Wire Serial Interface
 - QSPI™, SPI™ and Microwire™ Compatible
- On-Chip Output Buffer
- Rail-to-Rail Operation
- On-Chip Control Register
- Low Power Operation: 2.3 mA @ 3.3 V
- Full Power-Down to 1 μA max, typically 80 nA

APPLICATIONS

- Portable Battery Powered Instruments
- Digital Gain and Offset Adjustment
- Programmable Voltage and Current Sources
- Programmable Attenuators

GENERAL DESCRIPTION

The AD7303 is a dual, 8-bit voltage out DAC that operates from a single +2.7 V to +5.5 V supply. Its on-chip precision output buffers allow the DAC outputs to swing rail to rail. This device uses a versatile 3-wire serial interface that operates at clock rates up to 30 MHz, and is compatible with QSPI, SPI, microwire and digital signal processor interface standards. The serial input register is sixteen bits wide; 8 bits act as data bits for the DACs, and the remaining eight bits make up a control register.

The on-chip control register is used to address the relevant DAC, to power down the complete device or an individual DAC, to select internal or external reference and to provide a synchronous loading facility for simultaneous update of the DAC outputs with a software LDAC function.

The low power consumption of this part makes it ideally suited to portable battery operated equipment. The power consumption is 7.5 mW max at 3 V, reducing to less than 3 μW in full power-down mode.

The AD7303 is available in an 8-pin plastic dual in-line package, 8-lead SOIC and microSOIC packages.

QSPI and SPI are trademarks of Motorola.
Microwire is a trademark of National Semiconductor.

REV. 0

Information furnished by Analog Devices is believed to be accurate and reliable. However, no responsibility is assumed by Analog Devices for its use, nor for any infringements of patents or other rights of third parties which may result from its use. No license is granted by implication or otherwise under any patent or patent rights of Analog Devices.

FUNCTIONAL BLOCK DIAGRAM

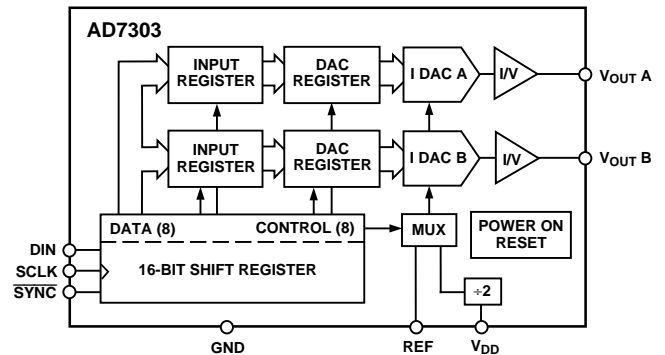

PRODUCT HIGHLIGHTS

1. Low power, single supply operation. This part operates from a single +2.7 V to +5.5 V supply and consumes typically 15 mW at 5.5 V, making it ideal for battery powered applications.
2. The on-chip output buffer amplifiers allow the outputs of the DACs to swing rail to rail with a settling time of typically 1.2 μs.
3. Internal or external reference capability.
4. High speed serial interface with clock rates up to 30 MHz.
5. Individual power-down of each DAC provided. When completely powered down, the DAC consumes typically 80 nA.

AD7303—SPECIFICATIONS ($V_{DD} = +2.7\text{ V to }+5.5\text{ V}$, Internal Reference; $R_L = 10\text{ k}\Omega$ to V_{DD} and GND; $C_L = 100\text{ pF}$ to GND; all specifications T_{MIN} to T_{MAX} unless otherwise noted)

Parameter	B Versions ¹	Units	Conditions/Comments
STATIC PERFORMANCE			
Resolution	8	Bits	
Relative Accuracy	± 1	LSB max	Note 2
Differential Nonlinearity	± 1	LSB max	Guaranteed Monotonic
Zero-Code Error @ +25°C	3	LSB max	All Zeros Loaded to DAC Register
Full-Scale Error	-0.5	LSB typ	All Ones Loaded to DAC Register
Gain Error ³	+1	% FSR typ	
Zero-Code Temperature Coefficient	100	$\mu\text{V}/^\circ\text{C}$ typ	
DAC REFERENCE INPUT			
REFIN Input Range	1 to $V_{DD}/2$	V min to max	
REFIN Input Impedance	10	M Ω typ	
Internal Voltage Reference Error ⁴	± 1	% max	
OUTPUT CHARACTERISTICS			
Output Voltage Range	0 to V_{DD}	V min to max	
Output Voltage Settling Time	2	μs max	Typically 1.2 μs
Slew Rate	7.5	V/ μs typ	
Digital to Analog Glitch Impulse	0.5	nV-s typ	1 LSB Change Around Major Carry
Digital Feedthrough	0.2	nV-s typ	
Digital Crosstalk	0.2	nV-s typ	
Analog Crosstalk	± 0.2	LSB typ	
DC Output Impedance	40	Ω typ	
Short Circuit Current	14	mA typ	
Power Supply Rejection Ratio	0.0001	%/ % max	$\Delta V_{DD} = \pm 10\%$
LOGIC INPUTS			
Input Current	± 10	μA max	
V_{INL} , Input Low Voltage	0.8	V max	$V_{DD} = +5\text{ V}$
	0.6	V max	$V_{DD} = +3\text{ V}$
V_{INH} , Input High Voltage	2.4	V min	$V_{DD} = +5\text{ V}$
	2.1	V min	$V_{DD} = +3\text{ V}$
Pin Capacitance	5	pF max	
POWER REQUIREMENTS			
V_{DD}	2.7/5.5	V min/max	
I_{DD} (Normal Mode)			Both DACs Active and Excluding Load Currents, $V_{IH} = V_{DD}$, $V_{IL} = \text{GND}$
$V_{DD} = 3.3\text{ V}$			See Figure 8
@ +25°C	2.1	mA max	
$T_{MIN} - T_{MAX}$	2.3	mA max	
$V_{DD} = 5.5\text{ V}$			
@ +25°C	2.7	mA max	
$T_{MIN} - T_{MAX}$	3.5	mA max	
I_{DD} (Full Power-Down)			$V_{IH} = V_{DD}$, $V_{IL} = \text{GND}$
@ +25°C	80	nA typ	See Figure 19
$T_{MIN} - T_{MAX}$	1	μA max	

NOTES

¹Temperature ranges are as follows: B Version, -40°C to +105°C.

²Relative Accuracy is calculated using a reduced digital code range of 15 to 245.

³Gain Error is specified between Codes 15 and 245. The actual error at Code 15 is typically 3 LSB.

⁴Internal Voltage Reference Error = $(\text{Actual } V_{REF} - \text{Ideal } V_{REF} / \text{Ideal } V_{REF}) \cdot 100$. Ideal $V_{REF} = V_{DD}/2$, actual V_{REF} = voltage on reference pin when internal reference is selected.

Specifications subject to change without notice.

ORDERING GUIDE

Model	Temperature Range	Package Options*
AD7303BN	-40°C to +105°C	N-8
AD7303BR	-40°C to +105°C	SO-8
AD7303BRM	-40°C to +105°C	RM-8

*N = Plastic DIP; R = SOIC; RM = microSOIC.

TIMING CHARACTERISTICS^{1, 2} ($V_{DD} = +2.7\text{ V to }+5.5\text{ V}$; $GND = 0\text{ V}$; Reference = Internal $V_{DD}/2$ Reference; all specifications T_{MIN} to T_{MAX} unless otherwise noted)

Parameter	Limit at T_{MIN} , T_{MAX} (B Version)	Units	Conditions/Comments
t_1	33	ns min	SCLK Cycle Time
t_2	13	ns min	SCLK High Time
t_3	13	ns min	SCLK Low Time
t_4	5	ns min	$\overline{\text{SYNC}}$ Setup Time
t_5	5	ns min	Data Setup Time
t_6	4.5	ns min	Data Hold Time
t_7	4.5	ns min	$\overline{\text{SYNC}}$ Hold Time
t_8	33	ns min	Minimum SYNC High Time

NOTES

¹Sample tested at +25°C to ensure compliance. All input signals are specified with $t_r = t_f = 5\text{ ns}$ (10% to 90% of V_{DD}) and timed from a voltage level of $(V_{IL} + V_{IH})/2$, t_r and t_f should not exceed 1 μs on any input.

²See Figures 1 and 2.

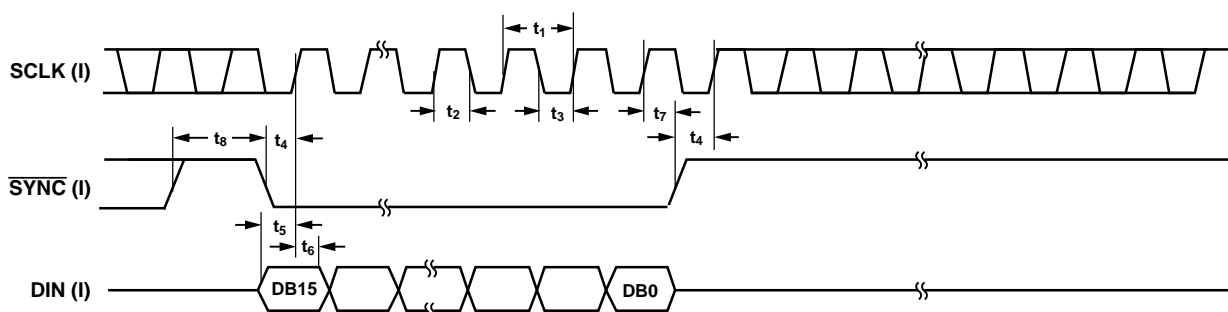

Figure 1. Timing Diagram for Continuous 16-Bit Write

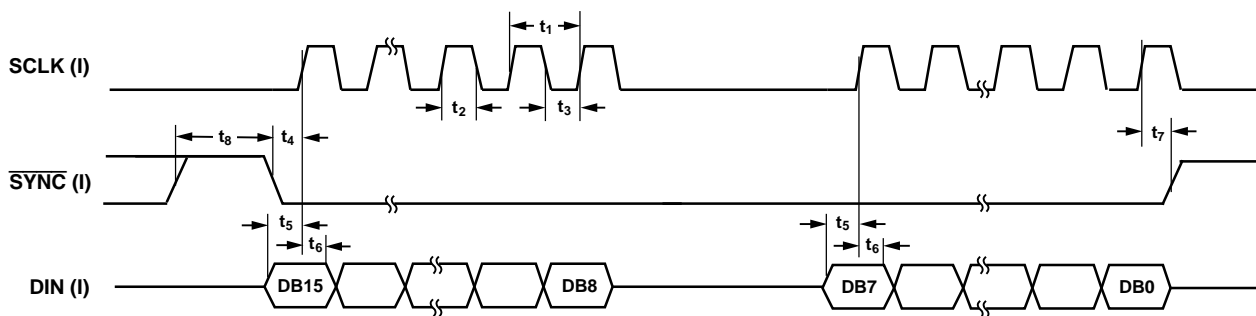

Figure 2. Timing Diagram for 2 x 8-Bit Writes

AD7303

ABSOLUTE MAXIMUM RATINGS*

(T_A = +25°C unless otherwise noted)

V _{DD} to GND	-0.3 V to +7 V
Reference Input Voltage to GND	-0.3 V to V _{DD} + 0.3 V
Digital Input Voltage to GND	-0.3 V to V _{DD} + 0.3 V
V _{OUT A} , V _{OUT B} to GND	-0.3 V to V _{DD} + 0.3 V
Operating Temperature Range		
Commercial (B Version)	-40°C to +105°C
Storage Temperature Range	-65°C to +150°C
Junction Temperature	+150°C
Plastic DIP Package, Power Dissipation		
θ _{JA} Thermal Impedance	117°C/W
Lead Temperature (Soldering, 10 sec)	+260°C

SOIC Package, Power Dissipation		
θ _{JA} Thermal Impedance	157°C/W
Lead Temperature, Soldering		
Vapor Phase (60 sec)	+215°C
Infrared (15 sec)	+220°C
MicroSOIC Package, Power Dissipation		
θ _{JA} Thermal Impedance	206°C/W
Lead Temperature, Soldering		
Vapor Phase (60 sec)	+215°C
Infrared (15 sec)	+220°C

*Stresses above those listed under “Absolute Maximum Ratings” may cause permanent damage to the device. This is a stress rating only; functional operation of the device at these or any other conditions above those listed in the operational sections of this specification is not implied. Exposure to absolute maximum rating conditions for extended periods may affect device reliability.

CAUTION

ESD (electrostatic discharge) sensitive device. Electrostatic charges as high as 4000 V readily accumulate on the human body and test equipment and can discharge without detection. Although the AD7303 features proprietary ESD protection circuitry, permanent damage may occur on devices subjected to high energy electrostatic discharges. Therefore, proper ESD precautions are recommended to avoid performance degradation or loss of functionality.



PIN CONFIGURATIONS (DIP, SOIC and microSOIC)



PIN FUNCTION DESCRIPTIONS

Pin No.	Mnemonic	Function
1	V _{OUT A}	Analog Output Voltage from DAC A. The output amplifier swings rail to rail on its output.
2	V _{DD}	Power Supply Input. These parts can be operated from +2.7 V to +5.5 V and should be decoupled to GND.
3	GND	Ground reference point for all circuitry on the part.
4	REF	External Reference Input. This can be used as the reference for both DACs, and is selected by setting the $\overline{\text{INT/EXT}}$ bit in the control register to a logic one. The range on this reference input is 1 V to V _{DD} /2. When the internal reference is selected, this voltage will appear as an output for decoupling purposes at the REF Pin. When using the internal reference, external voltages should not be connected to the REF Pin, see Figure 21.
5	SCLK	Serial Clock. Logic Input. Data is clocked into the input shift register on the rising edge of the serial clock input. Data can be transferred at rates up to 30 MHz.
6	DIN	Serial Data Input. This device has a 16-bit shift register, 8 bits for data and 8 bits for control. Data is clocked into the register on the rising edge of the clock input.
7	$\overline{\text{SYNC}}$	Level Triggered Control Input (active low). This is the frame synchronization signal for the input data. When $\overline{\text{SYNC}}$ goes low, it enables the input shift register and data is transferred in on the rising edges of the following clocks. The rising edge of the $\overline{\text{SYNC}}$ causes the relevant registers to be updated.
8	V _{OUT B}	Analog output voltage from DAC B. The output amplifier swings rail to rail on its output.

TERMINOLOGY**INTEGRAL NONLINEARITY**

For the DACs, relative accuracy or endpoint nonlinearity is a measure of the maximum deviation, in LSBs, from a straight line passing through the endpoints of the DAC transfer function. A graphical representation of the transfer curve is shown in Figure 15.

DIFFERENTIAL NONLINEARITY

Differential nonlinearity is the difference between the measured change and the ideal 1 LSB change of any two adjacent codes. A specified differential nonlinearity of ± 1 LSB maximum ensures monotonicity.

ZERO CODE ERROR

Zero code error is the measured output voltage from V_{OUT} of either DAC when zero code (all zeros) is loaded to the DAC latch. It is due to a combination of the offset errors in the DAC and output amplifier. Zero-scale error is expressed in LSBs.

GAIN ERROR

This is a measure of the span error of the DAC. It is the deviation in slope of the DAC transfer characteristic from ideal expressed as a percent of the full-scale value. Gain error is calculated between Codes 15 and 245.

FULL-SCALE ERROR

Full-Scale Error is a measure of the output error when the DAC latch is loaded with FF Hex. Full-scale error includes the offset error.

DIGITAL-TO-ANALOG GLITCH IMPULSE

Digital-to-analog glitch impulse is the impulse injected into the analog output when the digital inputs change state with the DAC selected and the software LDAC used to update the DAC. It is normally specified as the area of the glitch in nV-s and is measured when the digital input code is changed by 1 LSB at the major carry transition.

DIGITAL FEEDTHROUGH

Digital feedthrough is a measure of the impulse injected into the analog output of a DAC from the digital inputs of the same DAC, but is measured when the DAC is not updated. It is specified in nV-s and measured with a full-scale code change on the data bus, i.e., from all 0s to all 1s and vice versa.

DIGITAL CROSSTALK

Digital crosstalk is the glitch impulse transferred to the output of one converter due to a digital code change to another DAC. It is specified in nV-s.

ANALOG CROSSTALK

Analog crosstalk is a change in output of any DAC in response to a change in the output of the other DAC. It is measured in LSBs.

POWER SUPPLY REJECTION RATIO (PSRR)

This specification indicates how the output of the DAC is affected by changes in the power supply voltage. Power supply rejection ratio is quoted in terms of % change in output per % of change in V_{DD} for full-scale output of the DAC. V_{DD} is varied $\pm 10\%$. This specification applies to an external reference only because the output voltage will track the V_{DD} voltage when internal reference is selected.

AD7303—Typical Performance Characteristics

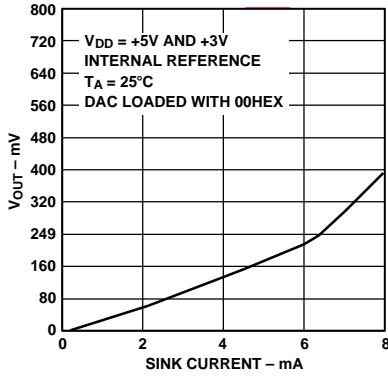

Figure 3. Output Sink Current Capability with $V_{DD} = 3\text{ V}$ and $V_{DD} = 5\text{ V}$



Figure 4. Output Source Current Capability with $V_{DD} = 5\text{ V}$

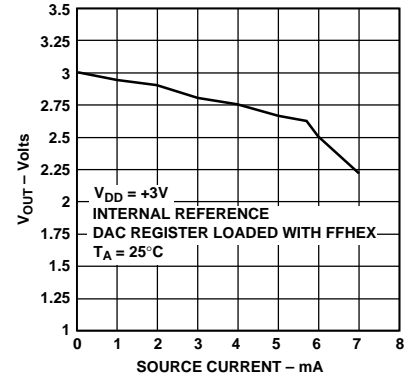

Figure 5. Output Source Current Capability with $V_{DD} = 3\text{ V}$

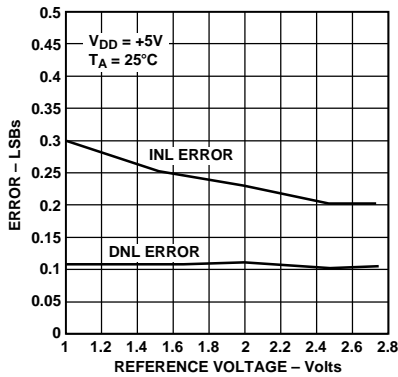

Figure 6. Relative Accuracy vs. External Reference

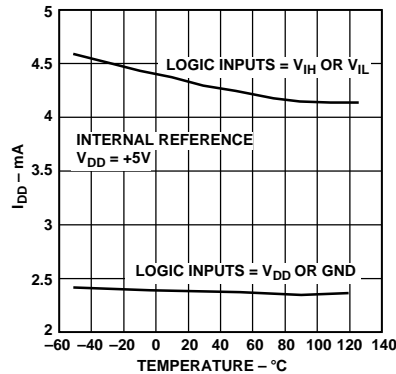

Figure 7. Supply Current vs. Temperature

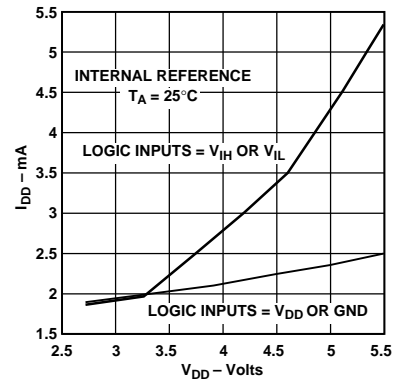

Figure 8. Supply Current vs. Supply Voltage

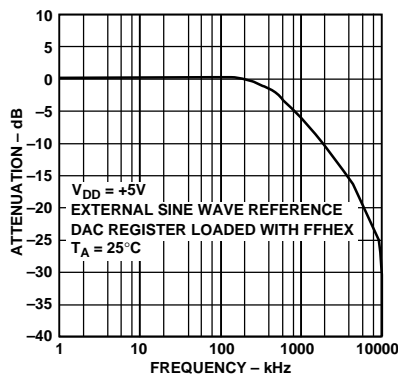

Figure 9. Large Scale Signal Frequency Response

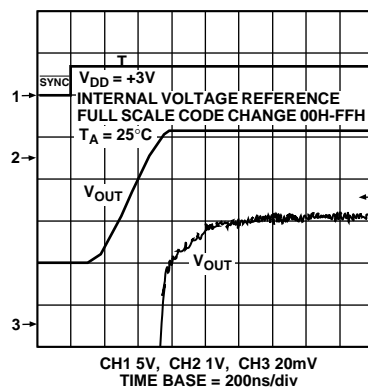

Figure 10. Full-Scale Settling Time

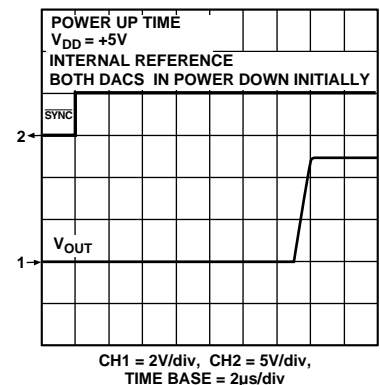

Figure 11. Exiting Power-Down (Full Power-Down)

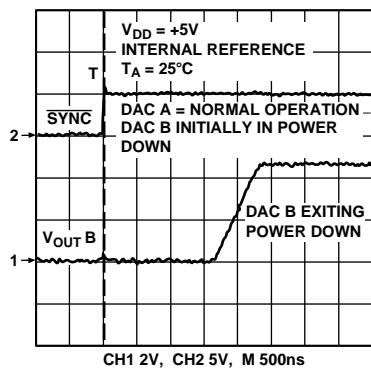

Figure 12. Exiting Power-Down (Partial Power-Down)

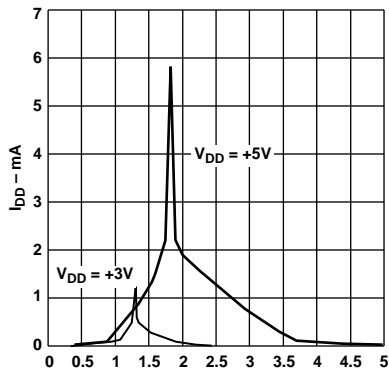

Figure 13. Supply Current vs. Logic Input Voltage

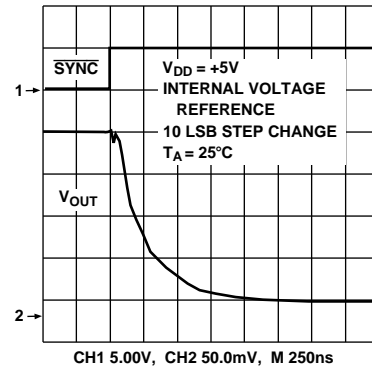

Figure 14. Small Scale Settling Time

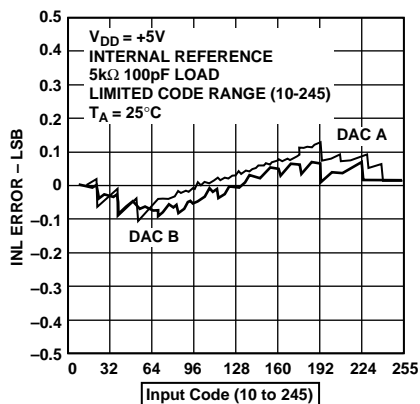

Figure 15. Integral Linearity Plot

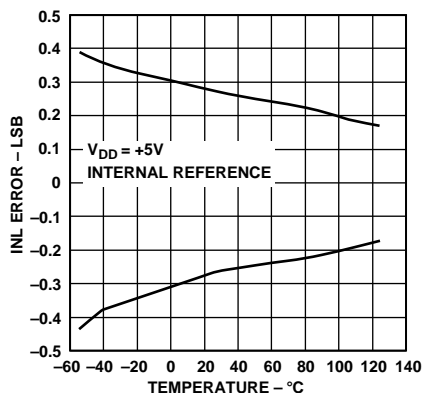

Figure 16. Typical INL vs. Temperature

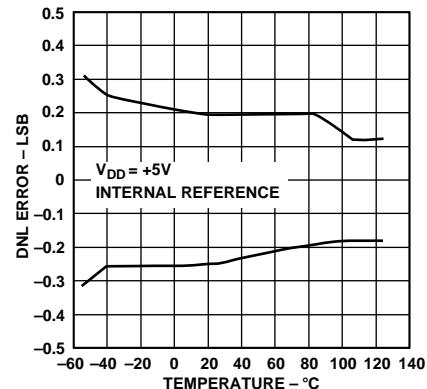

Figure 17. Typical DNL vs. Temperature

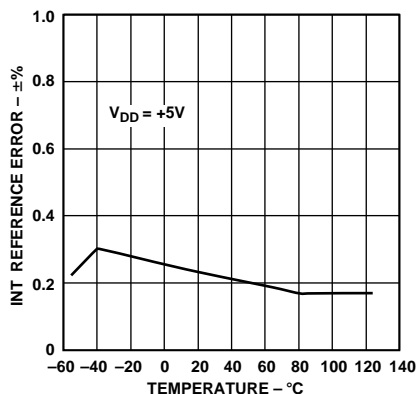

Figure 18. Typical Internal Reference Error vs. Temperature

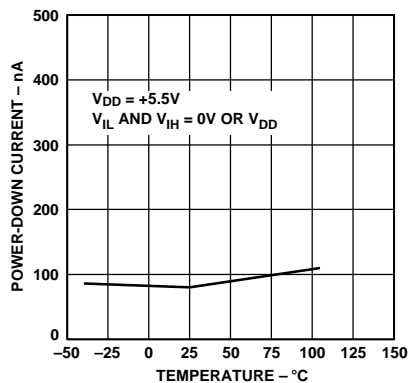

Figure 19. Power-Down Current vs. Temperature

AD7303

GENERAL DESCRIPTION

D/A Section

The AD7303 is a dual 8-bit voltage output digital-to-analog converter. The architecture consists of a reference amplifier and a current source DAC, followed by a current-to-voltage converter capable of generating rail-to-rail voltages on the output of the DAC. Figure 20 shows a block diagram of the basic DAC architecture.

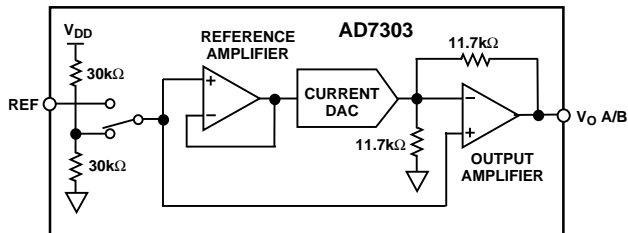

Figure 20. DAC Architecture

Both DAC A and DAC B outputs are internally buffered and these output buffer amplifiers have rail-to-rail output characteristics. The output amplifier is capable of driving a load of 10 kΩ to both V_{DD} and ground and 100 pF to ground. The reference selection for the DAC can be either internally generated from V_{DD} or externally applied through the REF pin. Reference selection is via a bit in the control register. The range on the external reference input is from 1.0 V to $V_{DD}/2$. The output voltage from either DAC is given by:

$$V_{O A/B} = 2 \times V_{REF} \times (N/256)$$

where:

V_{REF} is the voltage applied to the external REF pin or $V_{DD}/2$ when the internal reference is selected.

N is the decimal equivalent of the code loaded to the DAC register and ranges from 0 to 255.

Reference

The AD7303 has the facility to use either an external reference applied through the REF pin or an internal reference generated from V_{DD} . Figure 21 shows the reference input arrangement where the internal $V_{DD}/2$ has been selected.

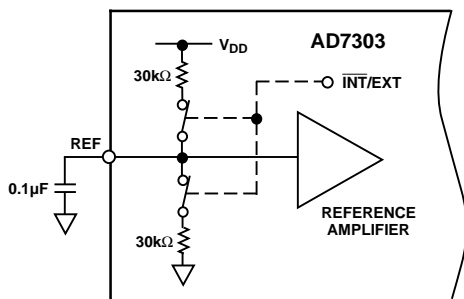

Figure 21. Reference Input

When the internal reference is selected during the write to the DAC, both switches are closed and $V_{DD}/2$ is generated and applied to the reference amplifier. This internal $V_{DD}/2$ reference appears at the reference pin as an output voltage for decoupling purposes. When using the internal reference, external references should not be connected to the REF Pin. This internal $V_{DD}/2$

reference appears at the reference pin as an output voltage for decoupling purposes. When using the internal reference, external references should not be connected to the REF pin. If external reference is selected, both switches are open and the externally applied voltage to the REF pin is applied to the reference amplifier.

Decoupling capacitors applied to the REF pin decouple both the internal reference and external reference. In noisy environments it is recommended that a 0.1 μF capacitor be connected to the REF pin to provide added decoupling even when the internal reference is selected.

Analog Outputs

The AD7303 contains two independent voltage output DACs with 8-bit resolution and rail-to-rail operation. The output buffer provides a gain of two at the output. Figures 3 to 5 show the sink and source capabilities of the output amplifier. The slew rate of the output amplifier is typically 8 V/μs and has a full-scale settling to 8 bits with a 100 pF capacitive load in typically 1.2 μs.

The input coding to the DAC is straight binary. Table I shows the binary transfer function for the AD7303. Figure 22 shows the DAC transfer function for binary coding. Any DAC output voltage can ideally be expressed as:

$$V_{OUT} = 2 \times V_{REF} (N/256)$$

where:

N is the decimal equivalent of the binary input code. N ranges from 0 to 255.

V_{REF} is the voltage applied to the external REF pin when the external reference is selected and is $V_{DD}/2$ if the internal reference is used.

Table I. Binary Code Table for AD7303 DAC

Digital Input MSB . . . LSB	Analog Output
1111 1111	$2 \times 255/256 \times V_{REF} V$
1111 1110	$2 \times 254/256 \times V_{REF} V$
1000 0001	$2 \times 129/256 \times V_{REF} V$
1000 0000	$V_{REF} V$
0111 1111	$2 \times 127/256 \times V_{REF} V$
0000 0001	$2 \times V_{REF}/256 V$
0000 0000	0 V

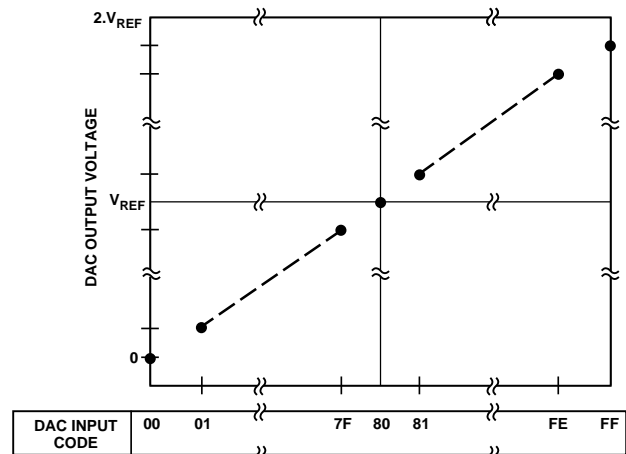

Figure 22. DAC Transfer Function

SERIAL INTERFACE

The AD7303 contains a versatile 3-wire serial interface that is compatible with SPI, QSPI and Microwire interface standards as well as a host of digital signal processors. An active low $\overline{\text{SYNC}}$ enables the shift register to receive data from the serial data input DIN. Data is clocked into the shift register on the rising edge of the serial clock. The serial clock frequency can be as high as 30 MHz. This shift register is 16 bits wide as shown in Figures 23 and 24. The first eight bits are control bits and the second eight bits are data bits for the DACs. Each transfer must consist of a 16-bit transfer. Data is sent MSB first and can be transmitted in one 16-bit write or two 8-bit writes. SPI and Microwire interfaces output data in 8-bit bytes and thus require two 8-bit transfers. In this case the $\overline{\text{SYNC}}$ input to the DAC should remain low until all sixteen bits have been transferred to the shift register. QSPI interfaces can be pro-

grammed to transfer data in 16-bit words. After clocking all sixteen bits to the shift register, the rising edge of $\overline{\text{SYNC}}$ executes the programmed function. The DACs are double buffered which allows their outputs to be simultaneously updated.

INPUT SHIFT REGISTER DESCRIPTION

The input shift register is 16 bits wide. The first eight bits consist of control bits and the last eight bits are data bits. Figure 23 shows a block diagram of the logic interface on the AD7303 DAC. The seven bits in the control word are taken from the input shift register to a latch sequencer that decodes this data and provides output signals that control the data transfers to the input and data registers of the selected DAC, as well as output updating and various power-down features associated with the control section. A description of all bits contained in the input shift register is given below.



Figure 23. Logic Interface on the AD7303

AD7303

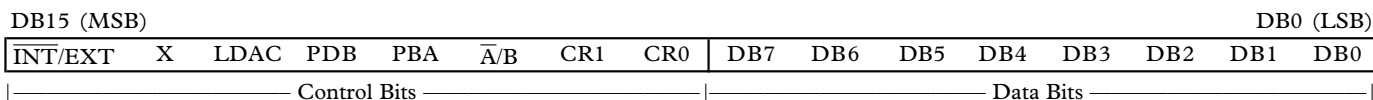

Figure 24. Input Shift Register Contents

Bit Location	Mnemonic	Description
DB15	$\overline{\text{INT/EXT}}$	Selects between internal and external reference.
DB14	X	Uncommitted bit.
DB13	LDAC	Load DAC bit for synchronous update of DAC outputs.
DB12	PDB	Power-down DAC B.
DB11	PDA	Power-down DAC A.
DB10	$\overline{\text{A/B}}$	Address bit to select either DAC A or DAC B.
DB9	CR1	Control Bit 1 used in conjunction with CR0 to implement the various data loading functions.
DB8	CR0	Control Bit 0 used in conjunction with CR1 to implement the various data loading functions.
DB7–DB0	Data	These bits contain the data used to update the output of the DACs. DB7 is the MSB and DB0 the LSB of the 8-bit data word.

CONTROL BITS

LDAC	$\overline{\text{A/B}}$	CR1	CR0	Function Implemented
0	X	0	0	Both DAC registers loaded from shift register.
0	0	0	1	Update DAC A input register from shift register.
0	1	0	1	Update DAC B input register from shift register.
0	0	1	0	Update DAC A DAC register from input register.
0	1	1	0	Update DAC B DAC register from input register.
0	0	1	1	Update DAC A DAC register from shift register.
0	1	1	1	Update DAC B DAC register from shift register.
1	0	X	X	Load DAC A input register from shift register and update both DAC A and DAC B DAC registers.
1	1	X	X	Load DAC B input register from shift register and update both DAC A and DAC B DAC registers outputs.

$\overline{\text{INT/EXT}}$	Function
0	Internal $V_{DD}/2$ reference selected.
1	External reference selected; this external reference is applied at the REF pin and ranges from 1 V to $V_{DD}/2$.

PDA	PDB	Function
0	0	Both DACs active.
0	1	DAC A active and DAC B in power-down mode.
1	0	DAC A in power-down mode and DAC B active.
1	1	Both DACs powered down.

POWER-ON RESET

The AD7303 has a power-on reset circuit designed to allow output stability during power-up. This circuit holds the DACs in a reset state until a write takes place to the DAC. In the reset state all zeros are latched into the input registers of each DAC, and the DAC registers are in transparent mode. Thus the output of both DACs are held at ground potential until a write takes place to the DAC.

POWER-DOWN FEATURES

Two bits in the control section of the 16-bit input word are used to put the AD7303 into low power mode. DAC A and DAC B can be powered down separately. When both DACs are powered down, the current consumption of the device is reduced to less than 1 μA , making the device suitable for use in portable battery powered equipment. The reference bias servo loop, the output amplifiers and associated linear circuitry are all shut down when the power-down is activated. The output sees a load of approximately 23 k Ω to GND when in power-down mode as shown in Figure 25. The contents of the data registers are unaffected when in power-down mode. The time to exit power-down is determined by the nature of the power-down, if the device is fully powered down the bias generator is also powered down and the device takes typically 13 μs to exit power-down mode. If the device is only partially powered down, i.e., only one channel powered down, in this case the bias generator is active and the time required for the power-down channel to exit this mode is typically 1.6 μs . See Figures 11 and 12.

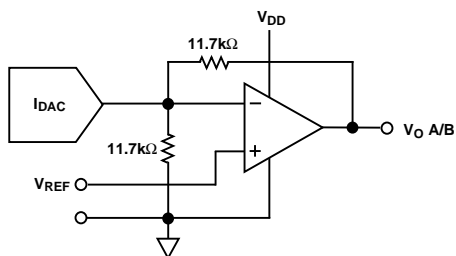
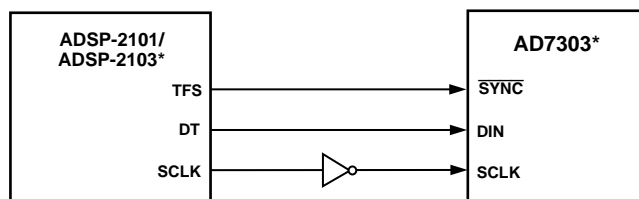

Figure 25. Output Stage During Power-Down

MICROPROCESSOR INTERFACING

AD7303 to ADSP-2101/ADSP-2103 Interface

Figure 26 shows a serial interface between the AD7303 and the ADSP-2101/ADSP-2103. The ADSP-2101/ADSP-2103 should be set up to operate in the SPORT Transmit Alternate Framing Mode. The ADSP-2101/ADSP-2103 SPORT is programmed through the SPORT control register and should be configured as follows: Internal Clock Operation, Active Low Framing, 16-Bit Word Length. Transmission is initiated by writing a word to the Tx register after the SPORT has been enabled. The data is clocked out on each falling edge of the serial clock and clocked into the AD7303 on the rising edge of the SCLK.



*ADDITIONAL PINS OMITTED FOR CLARITY

Figure 26. AD7303 to ADSP-2101/ADSP-2103 Interface

AD7303 to 68HC11/68L11 Interface

Figure 27 shows a serial interface between the AD7303 and the 68HC11/68L11 microcontroller. SCK of the 68HC11/68L11 drives the CLKIN of the AD7303, while the MOSI output drives the serial data line of the DAC. The SYNC signal is derived from a port line (PC7). The setup conditions for correct operation of this interface are as follows: the 68HC11/68L11 should be configured so that its CPOL bit is a 0 and its CPHA bit is a 0. When data is being transmitted to the DAC, the SYNC line is taken low (PC7). When the 68HC11/68L11 is configured as above, data appearing on the MOSI output is valid on the rising edge of SCK. Serial data from the 68HC11/68L11 is transmitted in 8-bit bytes with only eight falling clock edges occurring in the transmit cycle. Data is transmitted MSB first. In order to load data to the AD7303, PC7 is left low after the first eight bits are transferred, and a second serial write operation is performed to the DAC and PC7 is taken high at the end of this procedure.

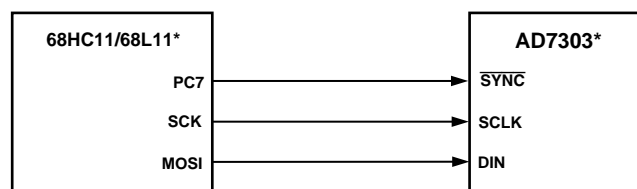

*ADDITIONAL PINS OMITTED FOR CLARITY

Figure 27. AD7303 to 68HC11/68L11 Interface

AD7303 to 80C51/80L51 Interface

Figure 28 shows a serial interface between the AD7303 and the 80C51/80L51 microcontroller. The setup for the interface is as follows: TXD of the 80C51/80L51 drives SCLK of the AD7303, while RXD drives the serial data line of the part. The SYNC signal is again derived from a bit programmable pin on the port. In this case port line P3.3 is used. When data is to be transmitted to the AD7303, P3.3 is taken low. The 80C51/80L51 transmits data only in 8-bit bytes; thus only eight falling clock edges occur in the transmit cycle. To load data to the DAC, P3.3 is left low after the first eight bits are transmitted, and a second write cycle is initiated to transmit the second byte of data. P3.3 is taken high following the completion of this cycle. The 80C51/80L51 outputs the serial data in a format which has the LSB first. The AD7303 requires its data with the MSB as the first bit received. The 80C51/80L51 transmit routine should take this into account.

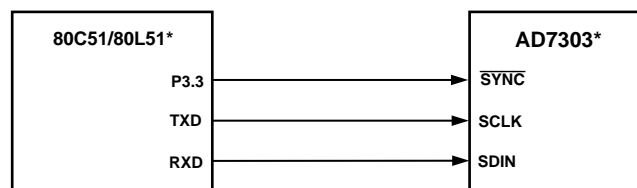

*ADDITIONAL PINS OMITTED FOR CLARITY

Figure 28. AD7303 to 80C51/80L51 Interface

AD7303

AD7303 to Microwire Interface

Figure 29 shows an interface between the AD7303 and any microwire compatible device. Serial data is shifted out on the falling edge of the serial clock and is clocked into the AD7303 on the rising edge of the SK.



*ADDITIONAL PINS OMITTED FOR CLARITY

Figure 29. AD7303 to Microwire Interface

APPLICATIONS

Typical Application Circuit

Figure 30 shows a typical setup for the AD7303 when using an external reference. The reference range for the AD7303 is from 1 V to $V_{DD}/2$ V. Higher values of reference can be incorporated but will saturate the output at both the top and bottom end of the transfer function. From input to output on the AD7303 there is a gain of two. Suitable references for 5 V operation are the AD780 and REF192. For 3 V operation, a suitable external reference would be the AD589, a 1.23 V bandgap reference.

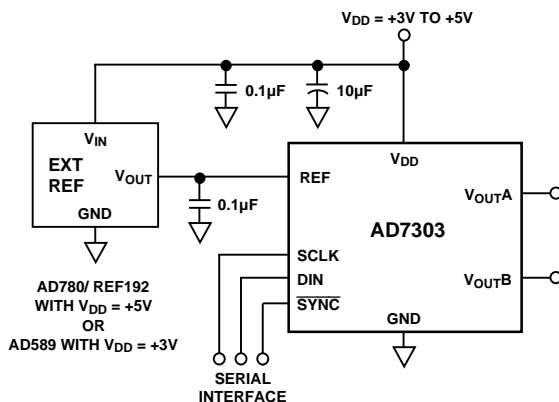

Figure 30. AD7303 Using External Reference

The AD7303 can also be used with its own internally derived $V_{DD}/2$ reference. Reference selection is through the \overline{INT}/EXT bit of the 16-bit input word. The internal reference, when selected, is also provided as an output at the REF pin and can be decoupled at this point with a 0.1 μ F capacitor for noise reduction purposes. AC references can also be applied as external references to the AD7303. The AD7303 has limited multiplying capability, and a multiplying bandwidth of up to 10 kHz is achievable.

Bipolar Operation Using the AD7303

The AD7303 has been designed for single supply operation, but bipolar operation is achievable using the circuit shown in Figure 31. The circuit shown has been configured to achieve an output voltage range of $-5 \text{ V} < V_O < +5 \text{ V}$. Rail-to-rail operation at the amplifier output is achievable using an AD820 or OP295 as the output amplifier.

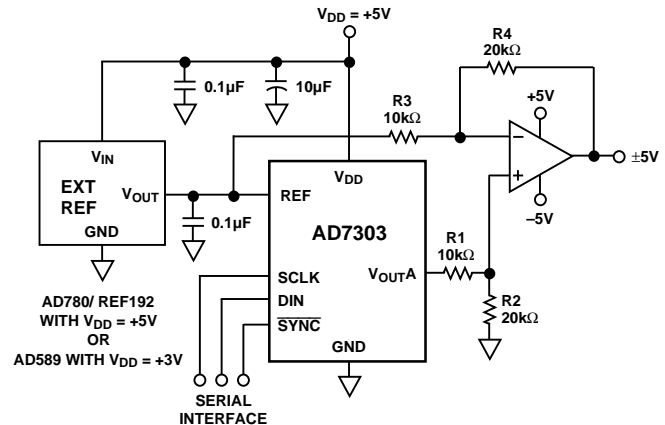

Figure 31. Bipolar Operation Using the AD7303

The output voltage for any input code can be calculated as follows:

$$V_O = [(1+R_4/R_3) * (R_2/(R_1+R_2) * (2 * V_{REF} * D/256))] - R_4 * V_{REF}/R_3$$

where

D is the decimal equivalent of the code loaded to the DAC and

V_{REF} is the reference voltage input.

With $V_{REF} = 2.5 \text{ V}$, $R_1 = R_3 = 10 \text{ k}\Omega$ and $R_2 = R_4 = 20 \text{ k}\Omega$ and $V_{DD} = 5 \text{ V}$.

$$V_{OUT} = (10 \times D/256) - 5$$

Opto-Isolated Interface for Process Control Applications

The AD7303 has a versatile 3-wire serial interface making it ideal for generating accurate voltages in process control and industrial applications. Due to noise, safety requirements or distance, it may be necessary to isolate the AD7303 from the controller. This can easily be achieved by using opto-isolators, which will provide isolation in excess of 3 kV. The serial loading structure of the AD7303 makes it ideally suited for use in opto-isolated applications. Figure 32 shows an opto-isolated interface to the AD7303 where DIN, SCLK and \overline{SYNC} are driven from opto-couplers. In this application the reference for the AD7303 is the internal $V_{DD}/2$ reference. It is being decoupled at the REF pin with a 0.1 μ F ceramic capacitor for noise reduction purposes.

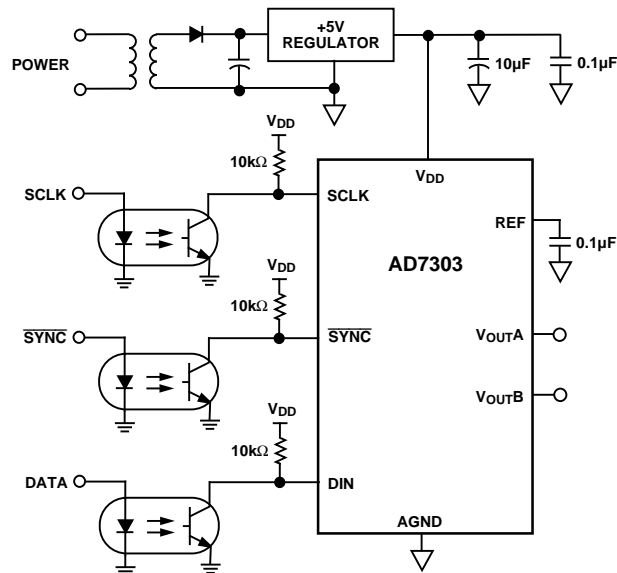

Figure 32. AD7303 in Opto-Isolated Interface

Decoding Multiple AD7303

The SYNC pin on the AD7303 can be used in applications to decode a number of DACs. In this application, all DACs in the system receive the same serial clock and serial data, but only the SYNC to one of the DACs will be active at any one time allowing access to two channels in this eight-channel system. The 74HC139 is used as a 2- to 4-line decoder to address any of the DACs in the system. To prevent timing errors from occurring, the enable input should be brought to its inactive state while the coded address inputs are changing state. Figure 33 shows a diagram of a typical setup for decoding multiple AD7303 devices in a system.

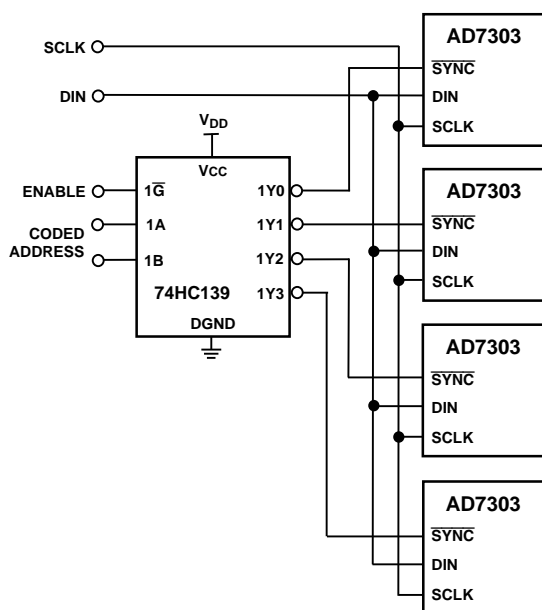

Figure 33. Decoding Multiple AD7303 Devices in a System

AD7303 as a Digitally Programmable Window Detector

A digitally programmable upper/lower limit detector using the two DACs in the AD7303 is shown in Figure 34. The upper and lower limits for the test are loaded to DACs A and B which, in turn, set the limits on the CMP04. If a signal at the VIN input is not within the programmed window, a led will indicate the fail condition.

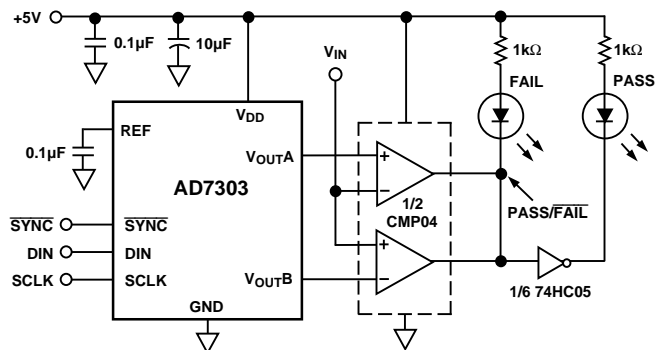

Figure 34. Window Detector Using AD7303

Programmable Current Source

Figure 35 shows the AD7303 used as the control element of a programmable current source. In this circuit, the full-scale current is set to 1 mA. The output voltage from the DAC is applied across the current setting resistor of 4.7 kΩ in series with the full-scale setting resistor of 470 Ω. Suitable transistors to place in the feedback loop of the amplifier include the BC107 and the 2N3904, which enable the current source to operate from a min V_{SOURCE} of 6 V. The operating range is determined by the operating characteristics of the transistor. Suitable amplifiers include the AD820 and the OP295, both having rail-to-rail operation on their outputs. The current for any digital input code can be calculated as follows:

$$I = 2 \times V_{REF} \times D / (5E + 3 \times 256) \text{ mA}$$

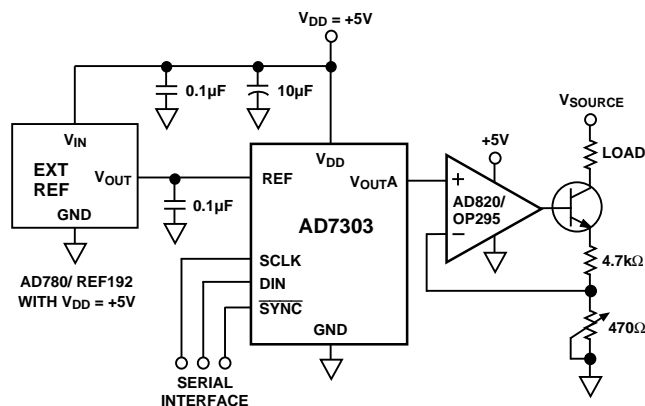

Figure 35. Programmable Current Source

AD7303

Power Supply Bypassing and Grounding

In any circuit where accuracy is important, careful consideration of the power supply and ground return layout helps to ensure the rated performance. The printed circuit board on which the AD7303 is mounted should be designed so that the analog and digital sections are separated, and confined to certain areas of the board. If the AD7303 is in a system where multiple devices require an AGND to DGND connection, the connection should be made at one point only. The star ground point should be established as closely as possible to the AD7303. The AD7303 should have ample supply bypassing of 10 μF in parallel with 0.1 μF on the supply located as closely to the package as possible, ideally right up against the device. The 10 μF capacitors are the tantalum bead type. The 0.1 μF capacitor should have low Effective Series Resistance (ESR) and Effective Series

Inductance (ESI), like the common ceramic types that provide a low impedance path to ground at high frequencies to handle transient currents due to internal logic switching.

The power supply lines of the AD7303 should use as large a trace as possible to provide low impedance paths and reduce the effects of glitches on the power supply line. Fast switching signals such as clocks should be shielded with digital ground to avoid radiating noise to other parts of the board, and should never be run near the reference inputs. Avoid crossover of digital and analog signals. Traces on opposite sides of the board should run at right angles to each other. This reduces the effects of feedthrough through the board. A microstrip technique is by far the best, but not always possible with a double-sided board. In this technique, the component side of the board is dedicated to ground plane while signal traces are placed on the solder side.

AD7303 to 68HC11 Interface Program Source Code

```

*
PORTC      EQU          $1003      Port C Control Register
*
*          "SYNC, 0, 0, 0, 0, 0, 0"
DDRC       EQU          $1007      Port C Data Direction
PORTD      EQU          $1008      Port D Data Register
*
*          "0, 0, 0, SCLK, DIN, 0, 0, 0"
DDRD       EQU          $1009      Port D Data Direction
SPCR       EQU          $1028      SPI Control Register
*
*          "SPIE, SPE, DWOM, MSTR, CPOL, CPHA, SPR1, SPR0"
SPSR       EQU          $1029      SPI Status Register
*
*          "SPIF, WCOL, 0, MODF, 0, 0, 0, 0"
SPDR       EQU          $102A      SPI Data Register, Read Buffer, Write Shifter
*
* SDI RAM Variables:
*          DIN 1 is eight MSBs, Control BYTE
*          DIN 2 is eight LSBs, Data BYTE
*          DAC requires 2*8-bit Writes
DIN1       EQU          $00        DIN BYTE 1: "INT/EXT, X, LDAC, PDB, PBA, A/B, CR1, CR0"
DIN2       EQU          $01        DIN BYTE 2: "DB7, DB6, DB5, DB4, DB3, DB2, DB1, DB0"
*
*          ORG          $C000      Start of users ram
INIT       LDS          #$CFFF     Top of C page Ram
*
*          LDAA         #$80      1, 0, 0, 0, 0, 0, 0, 0
*          SYNC is High
*          STAA         PORTC     Initialize Port C Outputs
*          LDAA         #$80      1, 0, 0, 0, 0, 0, 0, 0
*          STAA         DDRC      SYNC enabled as output
*
*          LDAA         #$00      0, 0, 0, 0, 0, 0, 0, 0
*          SCLK is low, DIN is low
*          STAA         PORTD     Initialize Port D outputs

```

	LDAA	#\$18	0, 0, 0, 1, 1, 0, 0, 0
*			SCLK and DIN enabled as outputs
	LDAA	#\$53	
	STAA	SPCR	SPI on, Master mode, CPOL=0, CPHA=0, Clock rate =E/32
*			
	BSR	UPDATE	Update AD7303 output.
	JMP	#\$E000	Restart.
*			
UPDATE	PSHX		Save relevant registers.
	PSHY		
	PSHA		
*			
	LDAA	#\$00	Control Word "0, 0, 0, 0, 0, 0, 0, 0"
	STAA	DIN 1	Load both DAC A and DAC B DAC registers from shift register with internal reference selected.
	LDAA	#\$AA	Data Word "1, 0, 1, 0, 1, 0, 1, 0"
	STAA	DIN 2	
*			
	LDX	#DIN1	Stack pointer at first first byte to send via DIN 1.
	LDY	#\$1000	Stack pointer at on chip registers.
*			
	BCLR	PORTC,Y \$80	Assert SYNC.
TRANSFER	LDAA	0,X	Get BYTE to transfer via SPI.
	STAA	SPDR	Write to DIN register to start transfer.
*			
WAIT	LDAA	SPSR	Wait for SPIF to be set to indicate that transfer has been completed.
	BPL	WAIT	SPIF is the MSB of the SPCR. SPIF is automatically reset if in a set state when the status register is read.
*			
	INX		Increment counter for transfer of second byte.
	CPX	#DIN 2+1	16 bits transferred?
	BNE	TRANSFER	If not, transfer second BYTE.
*Execute instruction			
	BSET	PORTC,Y \$80	Bring SYNC back high.
	PULA		Restore registers.
	PULY		
	PULX		
	RTS		Return to main program.

OUTLINE DIMENSIONS

Dimensions shown in inches and (mm).

8-Pin Plastic DIP
(N-8)



8-Lead SOIC
(SO-8)

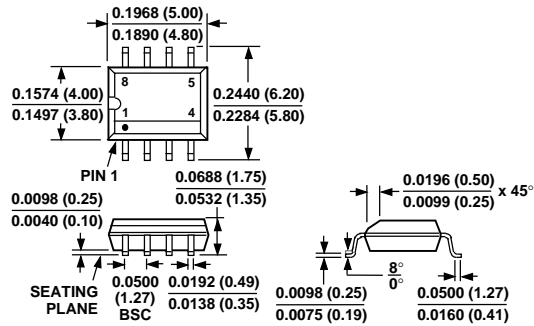

8-Lead microSOIC
(RM-8)





Компания «ЭлектроПласт» предлагает заключение долгосрочных отношений при поставках импортных электронных компонентов на взаимовыгодных условиях!

Наши преимущества:

- Оперативные поставки широкого спектра электронных компонентов отечественного и импортного производства напрямую от производителей и с крупнейших мировых складов;
- Поставка более 17-ти миллионов наименований электронных компонентов;
- Поставка сложных, дефицитных, либо снятых с производства позиций;
- Оперативные сроки поставки под заказ (от 5 рабочих дней);
- Экспресс доставка в любую точку России;
- Техническая поддержка проекта, помощь в подборе аналогов, поставка прототипов;
- Система менеджмента качества сертифицирована по Международному стандарту ISO 9001;
- Лицензия ФСБ на осуществление работ с использованием сведений, составляющих государственную тайну;
- Поставка специализированных компонентов (Xilinx, Altera, Analog Devices, Intersil, Interpoint, Microsemi, Aeroflex, Peregrine, Syfer, Eurofarad, Texas Instrument, Miteq, Cobham, E2V, MA-COM, Hittite, Mini-Circuits, General Dynamics и др.);

Помимо этого, одним из направлений компании «ЭлектроПласт» является направление «Источники питания». Мы предлагаем Вам помощь Конструкторского отдела:

- Подбор оптимального решения, техническое обоснование при выборе компонента;
- Подбор аналогов;
- Консультации по применению компонента;
- Поставка образцов и прототипов;
- Техническая поддержка проекта;
- Защита от снятия компонента с производства.



Как с нами связаться

Телефон: 8 (812) 309 58 32 (многоканальный)

Факс: 8 (812) 320-02-42

Электронная почта: org@eplast1.ru

Адрес: 198099, г. Санкт-Петербург, ул. Калинина, дом 2, корпус 4, литера А.